

Blancett®

B3000 FLOW MONITOR - For Gas or Liquid Meters -

PROGRAMMING & INSTALLATION MANUAL

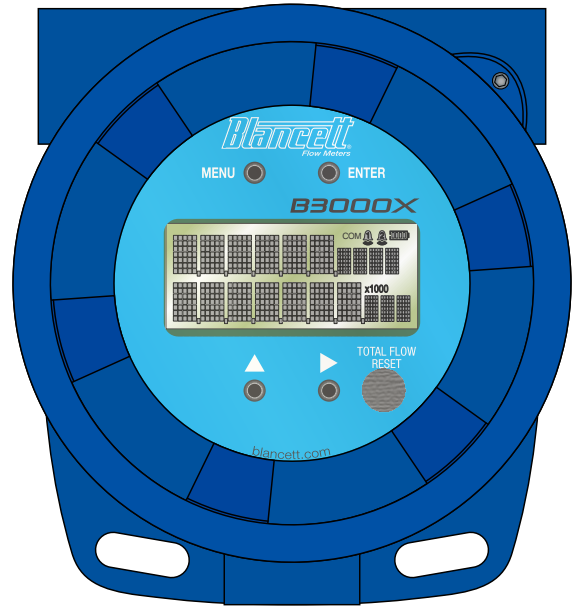
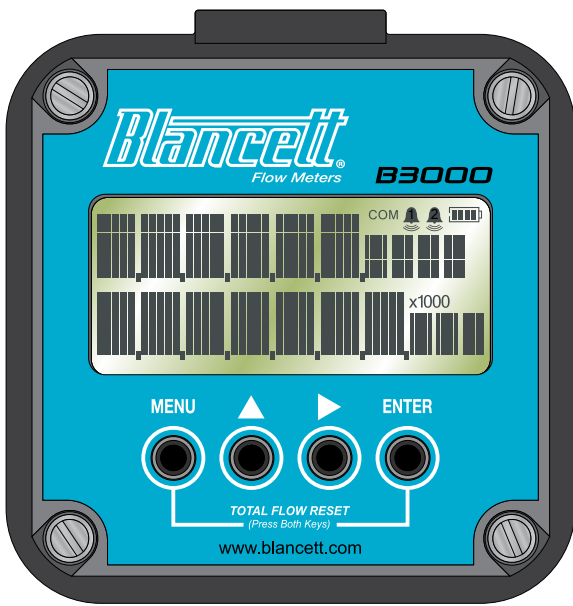

MODEL SERIAL

V Max	2.20mA Loop	Pulse Output	Reset Input (RS485)	Turbine Input
I Max	24 VDC	24 VDC	5 VDC	10 VDC
CI	0.5mA	0.5mA	0.5mA	0.5mA
LI	0.5mA	0.5mA	0.5mA	0.5mA

Electrical and Hazardous Location Safety
E112407

Warnings: Substitution of Components May Impair Intrinsic Safety. Use Only Intrinsic B3000/2000, 3.6V Lithium Battery. **AVERTISSEMENT:** La Substitution De Composants Peut Compromettre La Sécurité Intrinsèque. Utilisez Seulement Des Piles Batteries Blancett B3000/2000, 3.6V Lithium.

TRACnATEXxxxxx

CE 0518 Ex II 2 G Ex d IIB T4

MODEL: XXXXXXXXXX
S/N: 02XXXXXXMMYY

Do not open when an explosive atmosphere may be present.
WARNING: Do not open when energized. Install seal within 18 inches of enclosure.
Keep lightly closed when in operation.
S'il vous le circuit avant d'ouvrir le couvercle. Garder le couvercle bien fermé tant que les circuits sont sous tension.

TRAC12ATEX0017X

Ex II 2 G Ex d IIC T4 Gb
Ex II 2 D Ex tb IIIC T135°C Dg
Class I Div.1 Groups B, C, D;
Class II & III Div.1 Groups E, F, G;
Operating Temperature Code T4
Ta -30°C to 70°C
IP66
30VDC MAX --- 25mA
MADE IN USA

CE 0518

Electrical and Hazardous Location Safety
E112407

Warnings: Substitution of Components May Impair Intrinsic Safety. Use Only Intrinsic B3000/2000, 3.6V Lithium Battery. **AVERTISSEMENT:** La Substitution De Composants Peut Compromettre La Sécurité Intrinsèque. Utilisez Seulement Des Piles Batteries Blancett B3000/2000, 3.6V Lithium.

TRACnATEXxxxxx

CE 0518 Ex II 2 G Ex d IIB T4

MODEL SERIAL

V Max	2.20mA Loop	Pulse Output	Reset Input	Turbine Input
I Max	24 VDC	24 VDC	5 VDC	10 VDC
CI	0.5mA	0.5mA	0.5mA	0.5mA
LI	0.5mA	0.5mA	0.5mA	0.5mA

Electrical and Hazardous Location Safety
E112407

Warnings: Substitution of Components May Impair Intrinsic Safety. Use Only Intrinsic B3000/2000, 3.6V Lithium Battery. **AVERTISSEMENT:** La Substitution De Composants Peut Compromettre La Sécurité Intrinsèque. Utilisez Seulement Des Piles Batteries Blancett B3000/2000, 3.6V Lithium.

TRACnATEXxxxxx

CE 0518 Ex II 2 G Ex d IIB T4



8635 Washington Avenue
Racine, Wisconsin 53406
Toll Free: 800.235.1638

Phone: 262.639.6770 • Fax: 262.417.1155

www.blancett.com



TABLE OF CONTENTS

INTRODUCTION.....	4
INSTALLATION.....	5
CONNECTING THE B3000 TO A FREQUENCY OUTPUT DEVICE.....	5
POWER CONNECTIONS.....	8
OPERATING THE MONITOR	10
PROGRAMMING MODE	10
PROGRAMMING USING FREQUENCY OUTPUT TURBINE FLOW METERS	11
ESSENTIALS	11
PROGRAMMING PARAMETERS	12
CONVENTIONS	12
GAS COMPENSATION.....	18
SETPOINTS	25
APPENDIX	29
TROUBLESHOOTING GUIDE.....	29
DEFAULT K-FACTOR VALUES	29
BATTERY REPLACEMENT	30
SPECIFICATIONS.....	32
INTRINSICALLY SAFE INSTALLATION.....	34
LIQUID MENU MAPS	35
GAS MENU MAPS.....	38
K-FACTORS EXPLAINED.....	41
SYMBOL EXPLANATIONS	44
EXPLOSION-PROOF ENCLOSURE.....	45
B3000 MODBUS INTERFACE.....	48
MODBUS REGISTER / WORD ORDERING.....	48
REGISTER MAPPINGS.....	49
OPCODE 01 – READ COIL STATUS	50
OPCODE 03 – READ HOLDING REGISTERS	50
OPCODE 05 – FORCE SINGLE COIL.....	51
C SOURCE CODE	52
WASTE ELECTRICAL AND ELECTRONIC EQUIPMENT (WEEE) DIRECTIVE	53
CONTACTS AND PROCEDURES	54
LIMITED WARRANTY AND DISCLAIMER	55

NOTE: *Blancett reserves the right to make any changes or improvements to the product described in this manual at any time without notice.*

FIGURES

FIGURE 1 - B3000 FLOW MONITOR (NEMA 4)	6
FIGURE 2 - B3000 FLOW MONITOR (EX-PROOF)	6
FIGURE 3 - INPUT JUMPER SETTINGS NEMA 4.....	7
FIGURE 4 - INPUT JUMPER SETTINGS EX-PROOF	7
FIGURE 5 - TYPICAL MAGNETIC PICKUP CONNECTION (NEMA 4)	8
FIGURE 6 - TYPICAL MAGNETIC PICKUP CONNECTION (EX-PROOF)	8
FIGURE 7 - TYPICAL AMPLIFIED PICKUP CONNECTION (NEMA 4)	9
FIGURE 8 - TYPICAL AMPLIFIED PICKUP CONNECTION (EX-PROOF).....	9
FIGURE 9 - LOOP POWER CONNECTIONS (NEMA 4).....	10
FIGURE 10 - LOOP POWER CONNECTIONS (EX-PROOF)	10
FIGURE 11 - REQUIRED GROUNDING FOR EXPLOSION PROOF ENCLOSURE	10
FIGURE 12 - SOLAR POWERED B3000	11
FIGURE 13 - DISPLAY ANNUNCIATORS	12
FIGURE 14 - KEYPAD DETAIL.....	12
FIGURE 15 - PROGRAMMING MODE DISPLAY	14
FIGURE 16 - INSTANTANEOUS FLOW RATE AND CURRENT TOTAL	15
FIGURE 17 - GRAND TOTAL	16
FIGURE 18 - TEST MODE SCREEN.....	16
FIGURE 19 - OPEN DRAIN CONNECTIONS (NEMA 4)	22
FIGURE 20 - OPEN DRAIN CONNECTIONS (EX-PROOF)	22
FIGURE 21 - OPTO-ISOLATED OPEN COLLECTOR CONNECTIONS (NEMA 4)	22
FIGURE 22 - OPTO-ISOLATED OPEN COLLECTOR CONNECTIONS (EX-PROOF) ..	22
FIGURE 23 - 4-20 MA CALIBRATION SETUP	23
FIGURE 24 - SETPOINT OUTPUT (NEMA 4)	27
FIGURE 25 - SETPOINT OUTPUT (EX-PROOF)	27
FIGURE 26 - SETPOINT ACTIONS	28
FIGURE 27 - SETPOINT EXAMPLE	29
FIGURE 28 - NEMA 4 HARDWARE RESET	30
FIGURE 29 - EX-PROOF HARDWARE RESET	30
FIGURE 30 - CIRCUIT BOARD REMOVAL	33
FIGURE 31 - BATTERY REPLACEMENT PARTS IDENTIFICATION.....	33

TABLES

TABLE 1 - DISPLAY MODE SELECTION INFORMATION	13
TABLE 2 - SAMPLE LINEARIZATION DATA	24
TABLE A1 - LIQUID K-FACTORS.....	30
TABLE A2 - GAS K-FACTORS	30
TABLE A3 - APPROVALS.....	46
TABLE MB1 - MODBUS COMMANDS	49
TABLE MB2 - AVAILABLE DATA FORMATS	49
TABLE MB3 - MODBUS REGISTER MAP FOR 'LITTLE-ENDIAN' WORD ORDER MASTER DEVICES	50
TABLE MB4 - MODBUS REGISTER MAP FOR 'BIG-ENDIAN' WORD ORDER MASTER DEVICES	50
TABLE MB5 - MODBUS COIL MAP.....	51
TABLE MB6 - READ COIL STATUS.....	51
TABLE MB7 - FORCE SINGLE COIL	52

INTRODUCTION

The B3000 flow monitor incorporates state-of-the-art, digital signal processing technology, designed to provide the user with exceptional flexibility at a very affordable price. Though designed for use with Blancett flow sensors, this monitor can be used with almost any flow sensor producing a low amplitude AC output or contact closure signal.

This monitor is capable of accepting low-level frequency input signals typically found in turbine flow sensors. The output signal for these type of sensors is a frequency proportional to the rate of flow. The B3000 monitor uses the frequency information to calculate flow rate and total flow. Through the use of the programming buttons the user can select rate units, total units and unit time intervals among other functions. All B3000 flow monitors come pre-configured from the factory, if ordered with a Blancett flow sensor. If required, however, it can easily be re-configured in the field. Finally, the user can choose between simultaneously showing rate and total, or alternating between rate and grand total.

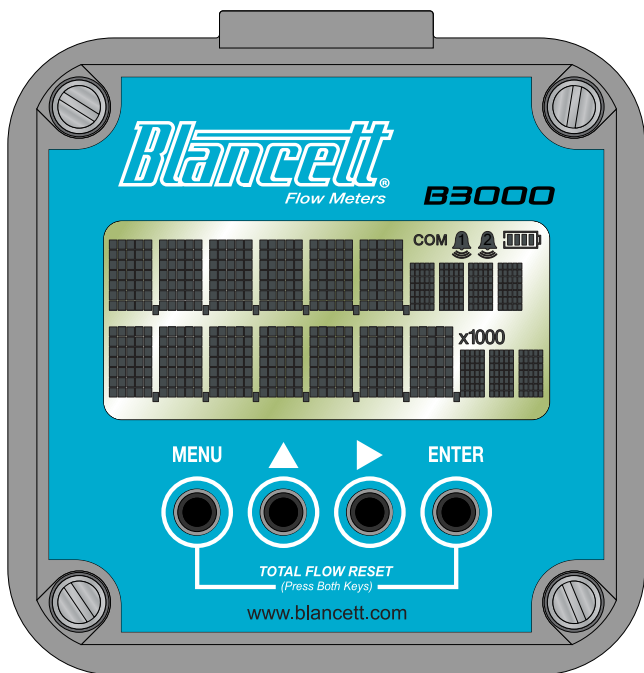

FIGURE 1 - B3000 FLOW MONITOR (NEMA 4)

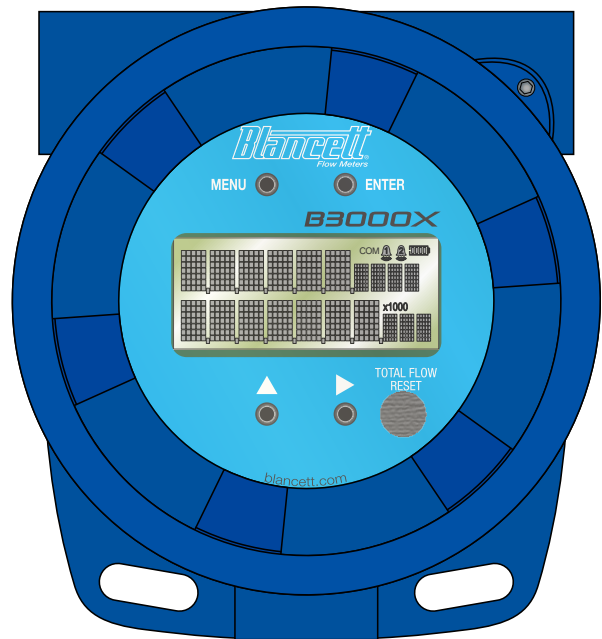

FIGURE 2 - B3000 FLOW MONITOR (EX-PROOF)

The monitor is available in two different levels of functionality and two packaging options. The Base model provides all the functions necessary for the most common flow metering applications. The Advanced version adds communications capabilities over an RS485 bus using Modbus RTU and control outputs. Completing the line is a solar powered model (NEMA 4X Only).

Packaging options include a polycarbonate, NEMA 4X version and an aluminum explosion proof enclosure.

INSTALLATION

CONNECTING THE B3000 TO A FREQUENCY OUTPUT DEVICE

Most turbine flow sensors produce a frequency output that is directly proportional to the volumetric flow through the sensor. There are, however, different output waveforms that can be presented to the display device depending on the transducer that converts the mechanical motion of the turbine into an electrical signal.

The B3000 monitor has two jumpers that are used to set the type of signal and the minimum amplitude of the signal that it will accept. The first thing that must be established is the type of output provided by the flow sensor. The outputs almost always fall into one of two types.

Type 1 - This is the unaltered frequency signal that comes from an un-amplified magnetic pickup. This signal is normally a sine wave in appearance and the amplitude of the waveform varies with the flow. Small turbines have comparatively small rotating masses so they produce a smaller amplitude waveform and higher frequencies than larger turbine sensors.

Type 2 - The frequency signal from the transducer is amplified, wave shaped or both to produce a waveform of a specified type and amplitude. Most amplified transducers output a square wave shape at one of many standard amplitudes. For example a popular amplified output is a 10 VDC square wave.

If the flow sensors output signal is type 1 the minimum amplitude of the frequency output must also be determined. The B3000 has a high and low sensitivity setting. High sensitivity (30 mV) would be used with low amplitude (usually small) turbine flow sensors. The Low sensitivity setting (60 mV) would typically be used for larger turbines and amplified transducers (See **Figures 3 & 4**).

NOTE: The High setting should only be used where the minimum signal amplitude is below 60 mV. Setting the sensitivity lower than necessary opens the instrument up to a greater possibility of noise interference.

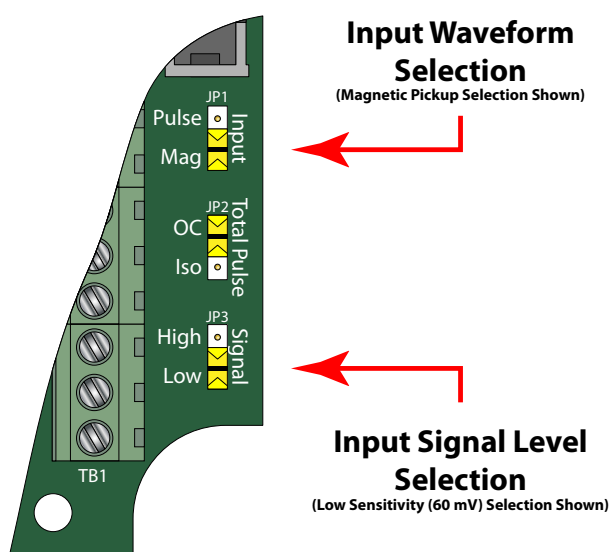

FIGURE 3 - INPUT JUMPER SETTINGS NEMA 4

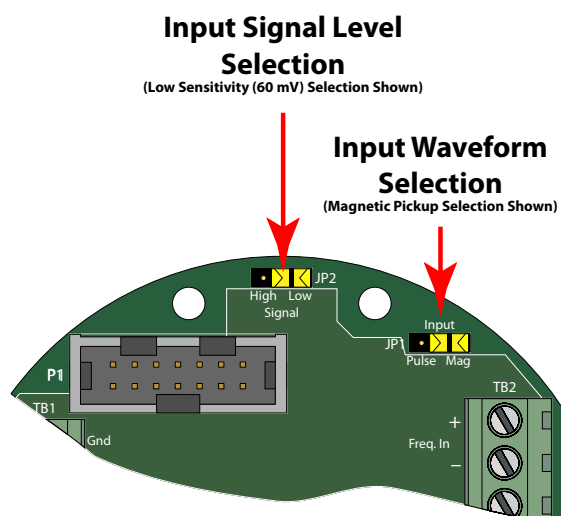

FIGURE 4 - INPUT JUMPER SETTINGS EX-PROOF

Once the type of waveform and input signal level (amplitude) have been determined the jumpers on the B3000 circuit board can be set.

For typical variable reluctance magnetic pickups the waveform selection jumper should be set for "Mag". The setting for the input level must be determined from looking at the magnetic pickup specifications. If the minimum amplitude at the minimum rated flow is greater than 60 mV use the Low Signal jumper position (See **Figures 5 & 6**).

If the minimum signal level is below 60 mV use the High Signal jumper position.

Again all B3000 flow monitors come pre-configured from the factory, if ordered with a Blancett flow sensor.

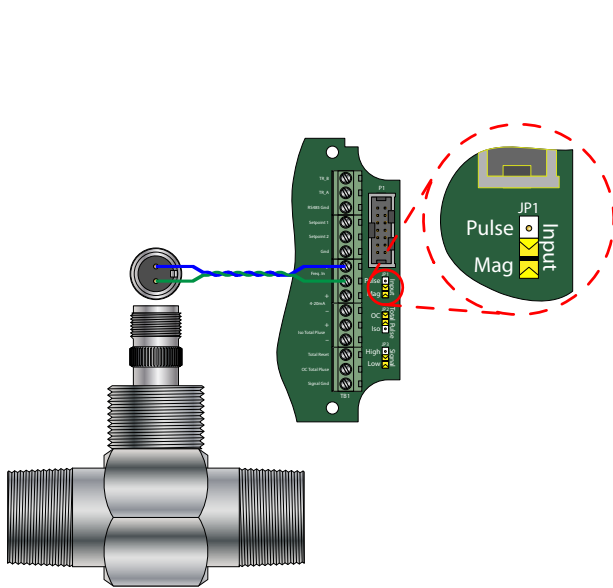

FIGURE 5 - TYPICAL MAGNETIC PICKUP CONNECTION (NEMA 4)

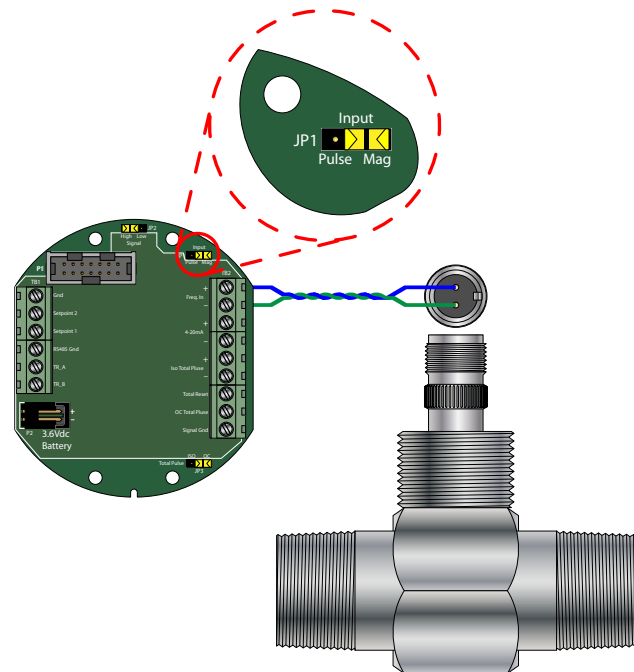

FIGURE 6 - TYPICAL MAGNETIC PICKUP CONNECTION (EX-PROOF)

For amplified input signals the Input jumper should be set to "Pulse" and the Signal jumper set to "Low" (See **Figures 7 & 8**).

NOTE: Amplified magnetic pickups will require an external power source. The B3000 does not supply power to the amplified pickup.

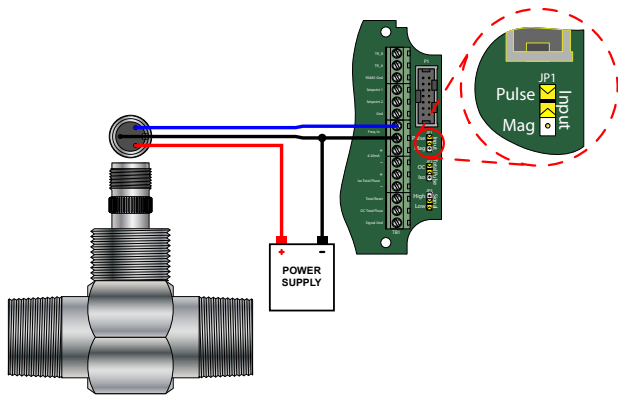

FIGURE 7 - TYPICAL AMPLIFIED PICKUP CONNECTION (NEMA 4)

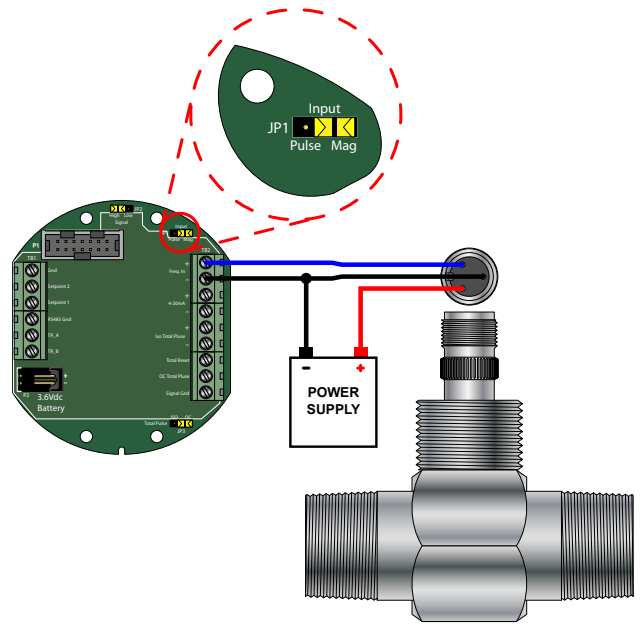

FIGURE 8 - TYPICAL AMPLIFIED PICKUP CONNECTION (EX-PROOF)

POWER CONNECTIONS

STANDARD

The B3000 has two power supply options. The standard power supply is an internal lithium 3.6 VDC “D” cell that will power the monitor for about 6 years with no outputs being used. The monitor can also derive power from a 4-20 mA current loop (See **Figures 9 & 10**). If the current loop is used a sensing circuit within the monitor detects the presence of the current loop and disconnects the battery from the circuit.

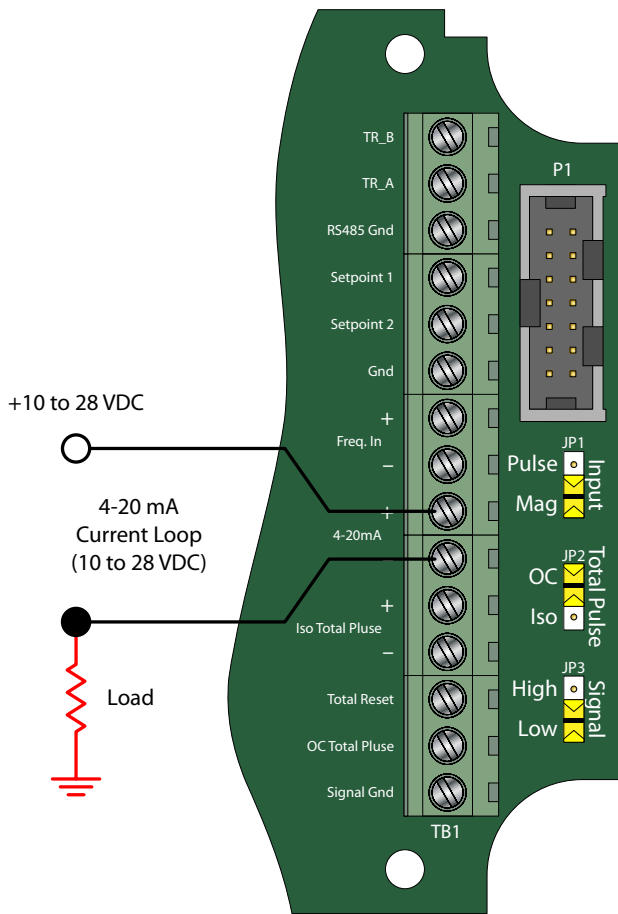

FIGURE 9 - LOOP POWER CONNECTIONS (NEMA 4)

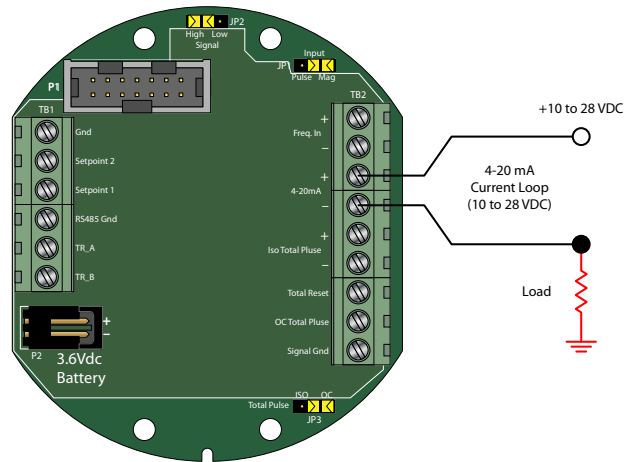

FIGURE 10 - LOOP POWER CONNECTIONS (EX-PROOF)



Caution: Grounding for the explosion proof enclosure is necessary. The explosion proof enclosure is provided with a grounding screw on the inside of the enclosure. The conductor used for grounding must be of a wire gage equal to or greater than the signal wires being used. See **Figure 11**

The explosion proof enclosure is provided with a grounding screw on the inside of the enclosure. The conductor used for grounding must be of a wire gage equal to or greater than the signal wires being used.

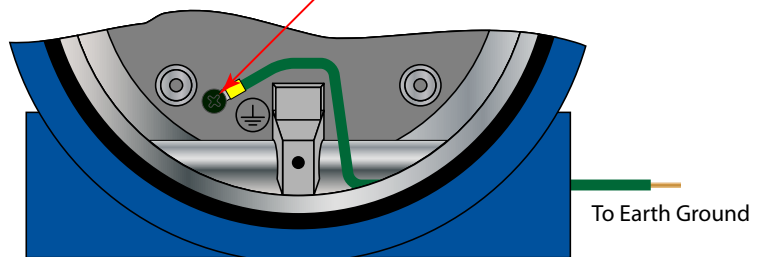

FIGURE 11 - REQUIRED GROUNDING FOR EXPLOSION PROOF ENCLOSURE

SOLAR

An optional solar powered variant is also available. The solar cell mounted on the top of the monitor charges an internal 3.6 VDC nickel-cadmium battery that powers the monitor. A fully charged Ni-Cad will run the monitor for approximately 30 days. The solar powered B3000 has a single totalizing pulse output and cannot be powered by a 4-20 mA loop.

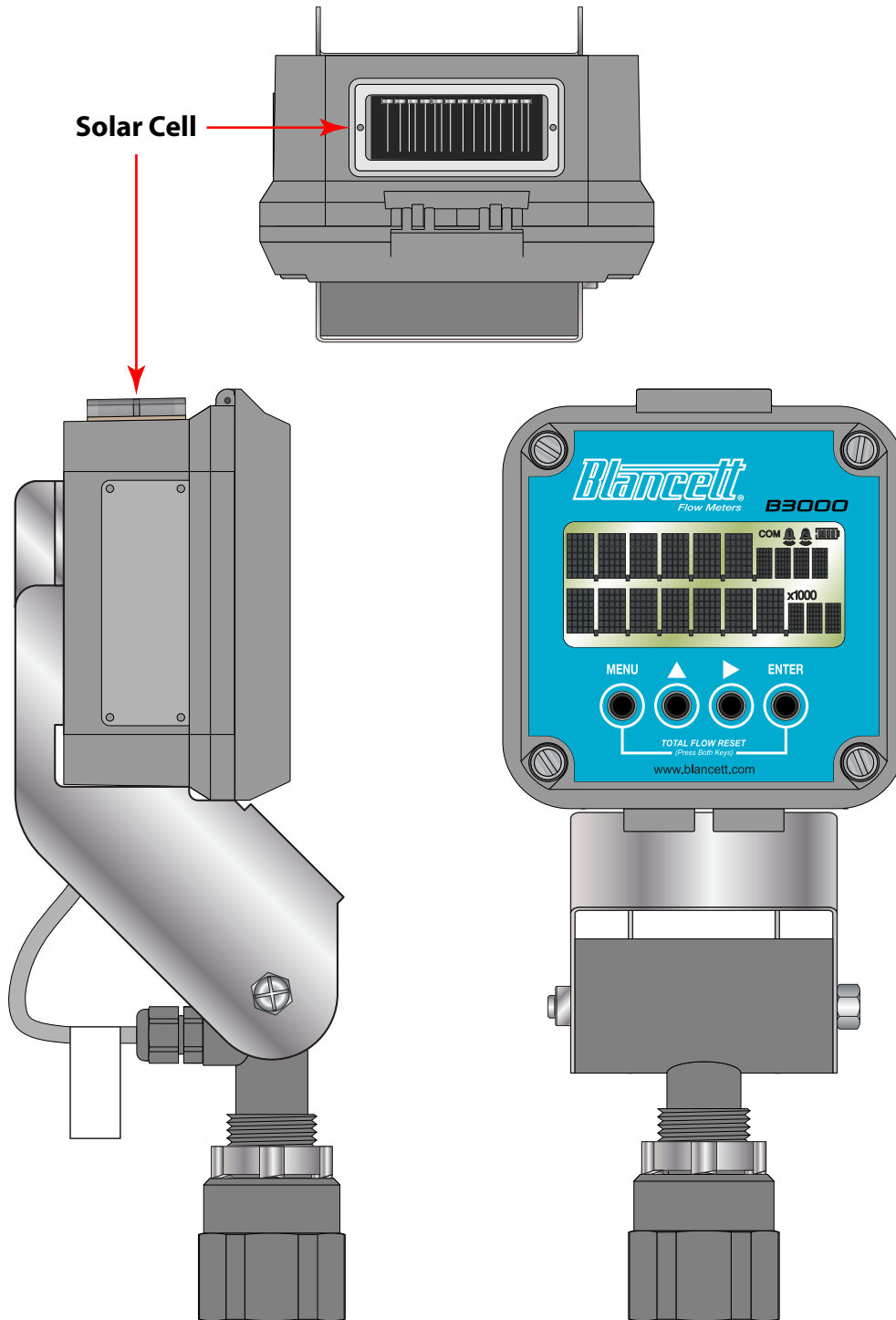

FIGURE 12 - SOLAR POWERED B3000

OPERATING THE MONITOR

The monitor has three modes of operation referred to as the **RUN**, **PROGRAMMING**, and **EXTENDED PROGRAMMING** modes.

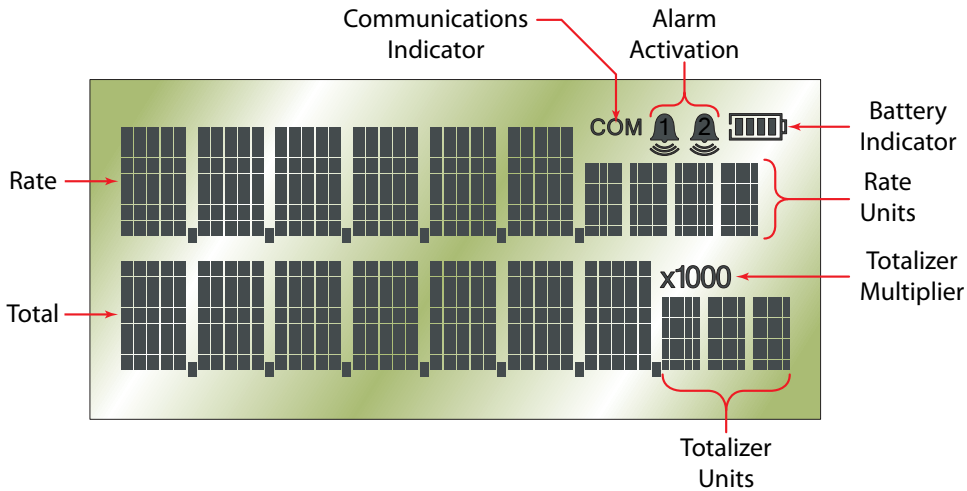

FIGURE 13 - DISPLAY ANNUNCIATORS

To access the **PROGRAM** mode, momentarily press and then release the **MENU** button until the first programming screen is displayed. The **EXTENDED PROGRAMMING** mode is entered by pressing and holding the **MENU** button until the first programming option appears. After programming the display with the necessary information, a lock out feature can be turned on to prevent unauthorized access or changing of the meter's setup parameters.

PROGRAMMING MODE

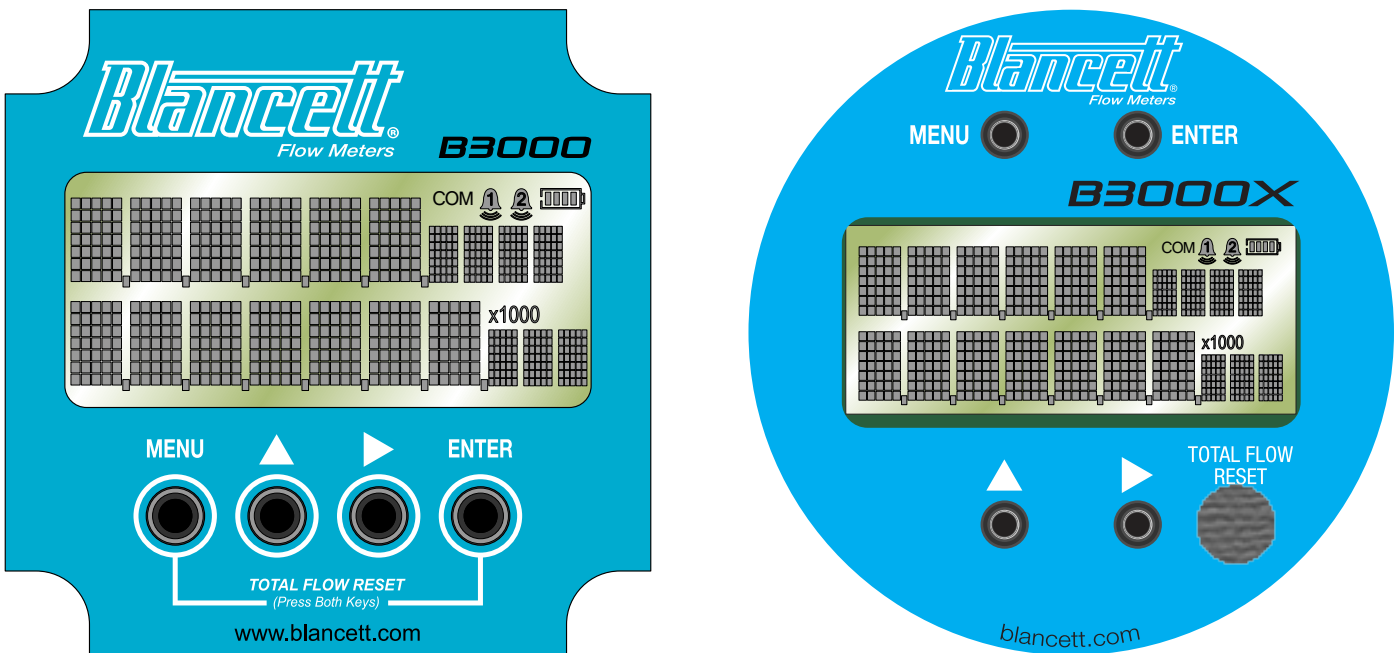

FIGURE 14 - KEYPAD DETAIL

BUTTONS

MENU – Switches between normal running and programming modes.

UP Arrow (▲) – In programming mode scrolls forward through the parameter choices and increments numeric variables.

RIGHT Arrow (▶) – In programming mode scrolls backward through the parameter choices and moves the active digit to the right.

ENTER – Used to save programming information, advance to the next programming parameter, and in the reset process.

TOTAL FLOW RESET - This touch sensor button allows the total to be reset without opening up the case. This button pertains to the **Explosion Proof** version only.

***NOTE:** The “through the glass” touch sensor button is currently under development in the explosion proof version of the B3000.*

SPECIAL FUNCTIONS

MENU + ENTER - Simultaneously press and hold to reset the current totalizer.

MENU - Press and hold menu key for 3 seconds to enter extended programming mode.

UP Arrow (▲) + Right Arrow (▶) - Simultaneously press and hold to show the firmware version number, then the grand total.

UP Arrow (▲) - In run mode increases display contrast.

RIGHT Arrow (▶) - In run mode decreases display contrast.

MODES

RUN – Normal operating mode.

PROGRAM – Used to program variables into the display.

EXTENDED PROGRAM – Used to program advanced variables into the display.

TEST – Used as a diagnostic tool to show input frequency and totalizer counts.

If your monitor was ordered with a Blancett flow sensor, the two components ship from the factory configured as a set. If the monitor is a replacement, the turbine's K-factor has changed, or the monitor is being used with some other pulse generating device; programming will be necessary.

PROGRAMMING USING FREQUENCY OUTPUT TURBINE FLOW METERS

Each Blancett turbine flow meter is shipped with either a K-factor value or frequency data. If frequency data is provided, the data must be converted to a K-factor before programming the monitor. K-factor information, when supplied, can usually be found on the neck of the flow meter or stamped on the flow meter body. The K-factor represents the number of pulses per unit of volume (See ***K-Factors Explained in the Appendix***). The K-factor will be needed to program the monitor.

ESSENTIALS

The B3000 monitor was engineered to provide several levels of programming tailored to the needs of the user. The first or standard level provides access to the most commonly used setup parameters bypassing the more advanced settings. The first level programming is entered by pressing and holding the **MENU** button for about 1 second.

The second level or extended settings are accessed by pressing and holding the **MENU** button until the extended programming menu starts.

With the Standard and Solar liquid monitors there is a third level. For the most basic unit setup choices the B3000 monitor has a Simple and Advanced setup option accessed through the **Rate SU** (Rate Setup) parameter. If Simple is chosen the rate and total choices are reduced to the five most common combinations avoiding the need to make unit and interval choices.

Liquid Meters	Standard	Solar	Advanced I/O
Basic Functions	Press the MENU for about 1 second and then release.		
Extended Functions	Press and <u>Hold</u> MENU button until the extended programming menu starts		
Simple Setup	Select Rate SU in the Extended Functions and choose Simple.		Not Applicable
Advanced Setup	Select Rate SU in the Extended Functions and choose Advanced.		

TABLE 1 - DISPLAY MODE SELECTION INFORMATION

ENTER PROGRAM MODE – The programming modes are accessed by pressing the **MENU** button once for basic functions. Extended functions are accessed by pressing and holding the **MENU** button until the first programming parameter appears.

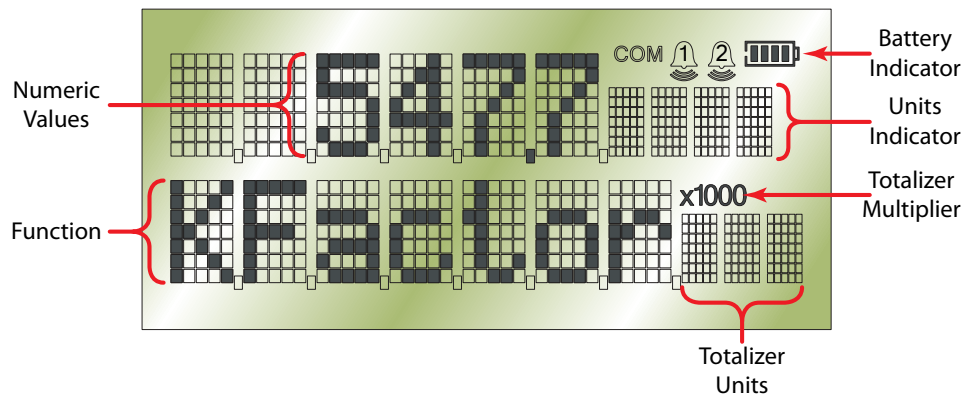

FIGURE 15 - PROGRAMMING MODE DISPLAY

PROGRAMMING PARAMETERS

CONVENTIONS

The individual programming parameters are arranged as follows.

Top Line - Indicates what the parameter is and if it is a "Selection" or an "Entry".

Bottom Line - Indicates what menu level the parameter resides in.

SELECT FLUID TYPE (Fluid)

Basic Function

At the Fluid Type prompt use the **▲** or **▶** buttons to select either **Liquid** or **Gas**.

NOTE: The fluid selection choice will affect what menu choices are available to the user. Consult the full **Menu Maps** in the appendix for further details.

NOTE: The following programming assumes the meter is set for Liquid. Parameters for gaseous fluids can be found later in the manual.

SELECT METER SIZE (Meter)

Basic Function

At the Meter prompt press the **ENTER** key to show the current meter size. Use the **▲** or **▶** buttons to select the correct meter size and press **ENTER** again to advance to the next parameter.

NOTE: The meter size selection refers to the bore of the meter and not the connections size. For a listing of the Blancett turbine bore sizes see the *Default K-Factor* table in the appendix.

SELECT DISPLAY FUNCTION (Display)

Extended Function

The B3000 monitor has three display selections.

(1) Flow (Flow)

The Flow (**Flow**) setting is used for normal operation of the monitor. In this mode the display shows both the instantaneous flow rate and current total simultaneously. **See Figure 16.**

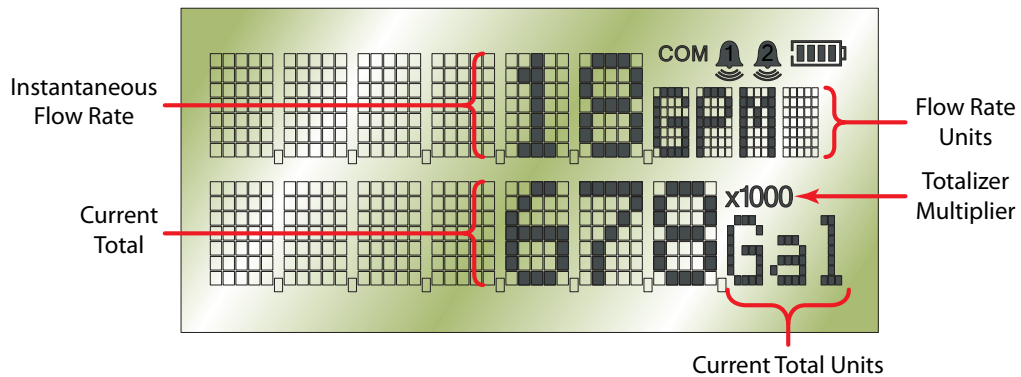

FIGURE 16 - INSTANTANEOUS FLOW RATE AND CURRENT TOTAL

(2) GRAND TOTAL (G-Total)

The Flow Grand Total (**Flow G-T**) choice forces the meter to alternate between the instantaneous flow and the grand total with roll-over counts. See **Figure 17**.

The grand total is the accumulation of all the fluid that has gone through the meter sense the last time the grand total was cleared. This totalizer is in addition to the current total totalizer on the display and is always enabled.

In addition the grand total screen also displays the number of times the grand total has reached its maximum count (9,999,999) and rolled over to zero.

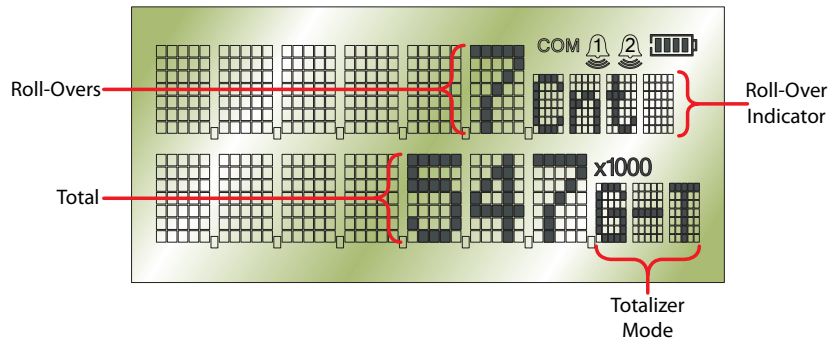

FIGURE 17 - GRAND TOTAL

(3) Test (Test)

The Test (**Test**) setting places the monitor into a special diagnostic mode that shows the current input frequency and the accumulated input counts. **Figure 18** shows the layout for test mode values. The diagnostic mode makes it possible for the user to see precisely the frequency input the monitor is seeing and is very useful in troubleshooting and noise detection.

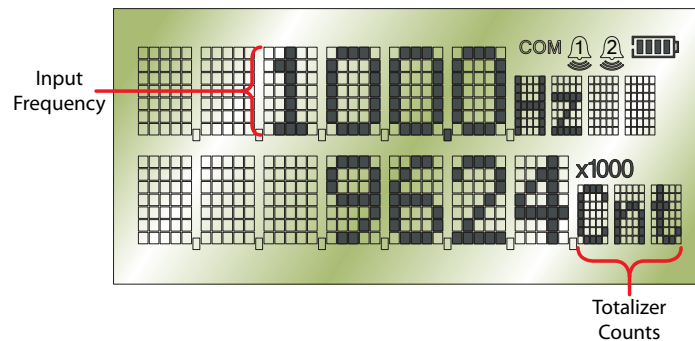

FIGURE 18 - TEST MODE SCREEN

If the current setting requires a change, press the ► arrow key to advance to the alternate choice. Once the correct choice is displayed, press **ENTER** key once to save the new selection and advance to the next parameter.

SELECT METER'S K-FACTOR UNIT (KFacUnt)

Basic Function

At the **K-Factor Unit** prompt, press the **ENTER** key once. The display now shows the current K-factor unit. If the current selection is correct, press the **ENTER** key to advance to the next parameter. For meters calibrated in gallons, use **Pul/Gal**; for meters calibrated in cubic meters, use **Pul/m³**; etc.

ENTER FLOW SENSORS K-FACTOR (KFactor)

Basic Function

NOTE: The K-factor supplied with your meter or calculated from calibration data will be needed to complete this step.

At the K-factor (**KFactor**) prompt, press the **ENTER** key once. The most significant digit in the K-factor will begin to flash. Using the **▲** arrow key, increment the display digit until it matches the meter's K-factor digit. If the current selection is correct, press the **▶** arrow key to advance to the next digit. Repeat this process until all K-factor digits have been entered. Press **ENTER** once to save the K-factor.

NOTE: The number of digits available before and after the decimal point is determined by the bore size of the flow sensor being used. The largest K-factors will be associated with the smallest bore sizes. The maximum allowable K-factor is 99999.9. The minimum must be at least 1.000. If an out of range number is entered the display will flash Limit (Limit) and refuse to allow the entry.

SELECT RATE UNIT SETUP (Rate SU)

Extended Function

The Rate Unit Setup (**Rate SU**) is only available on the Standard and Solar liquid monitors. For the most basic unit setup choices the B3000 monitor has a Simple and Advanced setup option accessed through the Rate Setup parameter. If Simple is chosen the rate and total choices are reduced to the five most common combinations avoiding the need to make unit and interval choices. When Advanced is selected the monitor allows access to all rate, total, and interval parameters.

SELECT FLOW RATE UNITS (Flo Unit)

Basic Function (Simple Setting)

The monitor allows the choice of many common rate units. Consult the Menu Maps or the Specifications in the appendix for all the unit choices. At the Flow Unit (**Flo Unit**) prompt, press the **ENTER** key once. The monitor now shows the current rate and totalizer units choice flashing on and off. If the current selection is correct, press the **ENTER** key to advance to the next parameter. To change to an alternate unit, use the **▲** or **▶** buttons to scroll to the desired rate unit and press **ENTER** to save the choice.

SELECT RATE (TIME) INTERVAL (RateInt)

Basic Function (Advanced Setting)

The term rate implies that something is occurring over a period of time. Most people are familiar with the speed of a car reported in miles per hour (MPH). The same concept holds true for a flow meters based on sensing velocity. The time choices are **Sec** (seconds), **Min** (minutes), **Hour** (hours), and **Day** (days). At the Rate Interval prompt, press the **ENTER** key once. The monitor now shows the current time interval choice flashing on and off. If the current selection is correct, press the **ENTER** key once to advance to the next parameter. To change to an alternate time interval, use the **▲** or **▶** buttons to scroll to the desired time interval and press **ENTER** to save the choice.

SELECT FLOW RATE UNITS (RateUnt) ***Basic Function (Advanced Setting)***

The monitor allows the choice of many common rate units. Consult the Menu Maps or the Specifications in the appendix for all the unit choices. At the Rate Unit (**RateUnt**) prompt, press the **ENTER** key once. The monitor now shows the current rate unit choice flashing on and off. If the current selection is correct, press the **ENTER** key to advance to the next parameter. To change to an alternate unit, use the **▲** or **▶** buttons to scroll to the desired rate unit and press **ENTER** to save the choice.

SELECT TOTAL UNITS OF MEASURE (TotlUnt) ***Basic Function (Advanced Setting)***

If a flow total is desirable, the units for the total must first be chosen. The monitor allows the choice of many common totalization units. Consult the Menu Maps or the Specifications in the appendix for all the unit choices. At the Total Unit (**TotlUnt**) prompt, press the **ENTER** key once. The monitor shows the current total units. If the current selection is correct, press the **ENTER** key once to advance to the next parameter. To change to an alternate unit, use the **▲** or **▶** buttons to scroll to the desired totalization unit and press **ENTER** to save the choice.

SELECT TOTAL MULTIPLIER (TotlMul) ***Basic Function (Advanced Setting)***

The monitor has a very versatile display that has the ability to accumulate the flow total in multiples of ten. For example, if the most desirable totalization unit is 1,000 gallons, the monitor can easily be set up for this requirement. Once the unit is back in run mode, every time the total display increments by one digit the actual total would be an additional 1,000 gallons. At 1,000 gallons the total display would read 1, at 3,000 gallons the total display would read 3, etc. This feature eliminates having to look at a total, count the digits, and mentally insert commas for each 1,000 multiple.

At the Total Multiplier (**TotlMul**) prompt, press the **ENTER** key once. The monitor now shows the current total multiplier. If the selection is correct, press the **ENTER** key to advance to the next parameter. To change to an alternate multiplier, use the **▲** or **▶** buttons to scroll to the desired multiplier unit and press **ENTER** to save the choice. The multiplier choices: **0.01** ($\div 100$), **0.1** ($\div 10$), **1**, **x10**, **x100**, **x1000** units

ENTER SPECIFIC GRAVITY VALUE (Spec Gr) ***Basic Function (activated when mass units are selected)***

The B3000 has two mass flow unit and two mass total unit choices (pounds and kilograms). When either pounds or kilograms are chosen in either the Rate Units (**RateUnt**) or Total Units (**TotlUnt**) parameters the Specific Gravity (**Spec Gr**) entry parameter is activated.

Mass readings in the B3000 are not temperature or pressure compensated so it is best to enter the specific gravity of the fluid as close to the system running temperature as possible. As liquids are essentially incompressible pressure compensation is not necessary for liquids.

ENTER A SCALE FACTOR (Scale F)

Extended Function

The scale factor is used to force a global span change. For example, under operating conditions the display is reading a consistent 3% below the expected values at all flow rates. Rather than changing the K-factor and linearization parameters individually, the scale factor can be used to compensate for the 3% offset. The scale factor would be set to 1.03 to correct the readings. The range of scale factors is from 0.10 to 5.00. The default scale factor is 1.00.

At the Scale Factor (**Scale F**) prompt, press the **ENTER** key once. The first digit of the existing scale factor, if any, will begin to flash. If the current selection is correct, press the **ENTER** key to advance to the next parameter.

If the current selection requires a change, use the ▲ arrow key, increment the display digit until it matches the first digit of the new scale factor. Next press the ► arrow key to advance to the next digit and using the ▲ arrow key, increment the second display digit until it matches the second digit of the new scale factor. Repeat this step for the third digit. Press **ENTER** once to save the new scale factor.

NOTE: *If an out of range number is entered the display will flash Limit (Limit) and refuse to allow the entry.*

PRESET TOTAL (SetTotl)

Extended Function

It is sometimes helpful to be able to set the totalizer to a predetermined number before starting a process. The B3000 allows this through the use of the set total menu entry. The preset is capable of seven digits or up to 8,888,888.

At the Preset Total (**SetTotl**) prompt, press the **ENTER** key twice. The first digit of the current preset total will begin to flash. If the current selection is correct, press the **ENTER** key to advance to the next parameter.

If the current selection requires a change, use the ▲ arrow key, increment the display digit until it matches the first digit of the desired preset. Next press the ► arrow key to advance to the next digit and using the ▲ arrow key, increment the second display digit until it matches the second digit of the preset. Repeat this step until the preset is complete. Press **ENTER** once to save the new preset.

NOTE: *If an out of range number is entered the display will flash Limit (Limit) and refuse to allow the entry.*

LOW FLOW CUTOFF (Cutoff)

Extended Function

A Low Flow Cut-off entry is provided to allow low flow rates (that can be present when pumps are off and valves are closed) to be displayed as zero flow. A typical value would be about 5% of the flow sensors maximum flow. This setting is a good compromise between suppression of noise and utilizing the full span of the flow sensor.

The low flow cutoff is entered as an actual flow value. For example if the maximum flow rate for the flow sensor was 100 GPM the low flow cutoff values should be set for 5% of 100 GPM. The entry would then be 5.0.

At the Low Flow Cut-off (**Cutoff**) prompt, press the **ENTER** key once. The first digit of the current low flow cut-off will begin to flash. If the current selection is correct, press the **ENTER** key to advance to the next parameter.

If the current selection requires a change, use the ▲ arrow key, increment the display digit until it matches the first digit of the desired low flow cut-off value. Next press the ► arrow key to advance to the next digit and using the ▲ arrow key, increment the second display digit until it matches the second digit of the preset. Repeat this step until the low flow cut-off is entered. Press **ENTER** once to save the new low flow cut-off.

NOTE: If an out of range number is entered the display will flash Limit (Limit) and refuse to allow the entry.

GAS COMPENSATION

(Gas Turbines Only)

Fluid measured by the gas turbine meter is compressible, and is also affected by temperature changes and pressure changes as illustrated by the ideal gas law equation (**Equation 1**):

$$\frac{P_1V_1}{T_1} = \frac{P_2V_2}{T_2}$$

Equation 1

Absolute Pressure and Temperature

The ideal gas law equation shows that the volume of gas is determined by pressure and temperature applied to the gas under running conditions. In this equation, the pressure, P, is absolute pressure the observed gauge pressure plus the atmospheric pressure. The commonly used domestic unit of measure for absolute pressure is pounds per square inch absolute (psia). Atmospheric pressure is considered to be 14.73 psi. Therefore, Absolute pressure (psia) is the sum of the gage pressure plus 14.73.

The absolute temperature in the equation above is expressed in degrees Rankine, which is calculated by adding 459.67 to the temperature in F°.

Because pressure and temperature have a large impact on the mass of gas moving through the flow meter both values must be entered into the B3000 for accurate gas readings to occur.

NOTE: The B3000 calculates the correct pressure and temperature values without having to convert to absolute pressure or degrees Rankine. The compensation values should be entered in psig and F°.

Operating Pressure (Op Pres)

Basic Function (Gas Only)

At the Operating Pressure (**Op Pres**) prompt, press the **ENTER** key. The first digit of the current pressure setting will begin to flash.

If the current selection requires a change, use the ▲ arrow key, increment the display digit until it matches the first digit of the desired pressure value. Next press the ► arrow key to advance to the next digit and using the ▲ arrow key, increment the second display digit until it matches the second digit of the operating pressure. When the correct pressure setting has been entered, press **ENTER** once to save the new pressure value.

Operating Temperature (Op Temp)

Basic Function (Gas Only)

At the Operating Temperature (**Op Temp**) prompt, press the **ENTER** key. The first digit of the current temperature setting will begin to flash.

If the current selection requires a change, use the ▲ arrow key, increment the display digit until it matches the first digit of the desired temperature value. Next press the ► arrow key to advance to the next digit and using the ▲ arrow key, increment the second display digit until it matches the second digit of the operating temperature. When the correct pressure setting has been entered, press **ENTER** once to save the new temperature value.

DAMPING FACTOR (Damping)

Extended Function

The damping factor is increased to enhance the stability of the flow readings. Damping values are decreased to allow the monitor to react faster to changing values of flow. This parameter can take on any value between 0 and 99 % with 0 being the default.

At the Damping prompt, press the **ENTER** key once. The current damping setting will begin to flash. If the current selection is correct, press the **ENTER** key to advance to the next parameter.

If the current selection requires a change, use the ▲ arrow key, increment the display digit until it matches the first digit of the desired damping value. Next press the ► arrow key to advance to the next digit and using the ▲ arrow key, increment the second display digit until it matches the second digit of the damping value. Press **ENTER** once to save the new damping value.

TOTALIZER PULSE OUTPUT (PulsOut)

Basic Function

The Pulse Output (**PulsOut**) parameter can be either **Enabled** or **Disabled**. When enabled, this output generates a fixed width 30 mS duration, pulse every time the least significant digit of the totalizer increments. The amplitude of the pulse is dependent on the voltage level of the supply connected to the pulse output and is limited to a maximum 28 VDC.

The B3000 provides two types of totalizer pulses. The basic open drain FET output, **Figures 19 & 20**, provides a ground referenced output pulse that swings between about 0.7 VDC and V_{CC} .

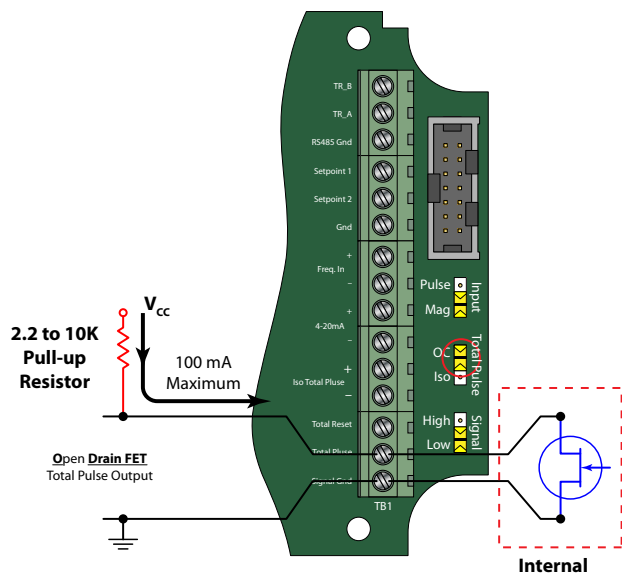

FIGURE 19 - OPEN DRAIN CONNECTIONS (NEMA 4)

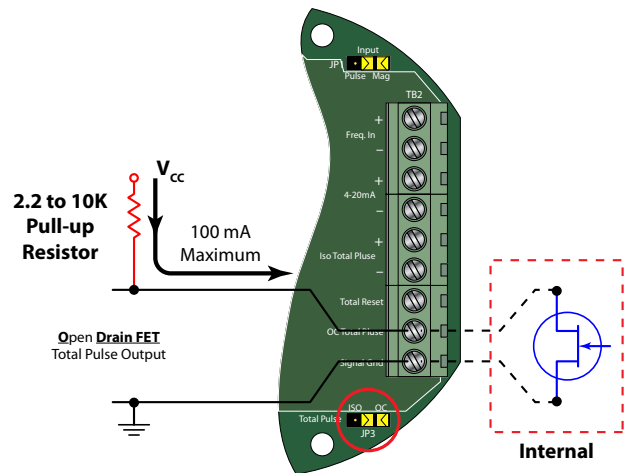

FIGURE 20 - OPEN DRAIN CONNECTIONS (EX-PROOF)

The isolated pulse output (ISO), **Figures 21 & 22**, are again an open collector output with the emitter of the transistor connected to the negative output terminal and is not referenced to ground. This output is optically isolated from the input signal for systems that require a totally isolated output pulse.

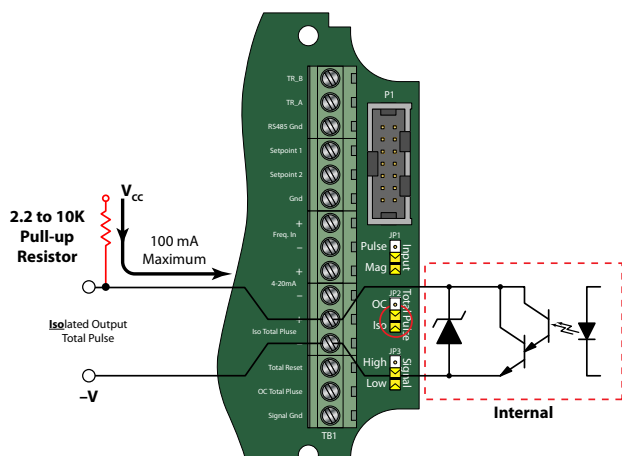

FIGURE 21 - OPTO-ISOLATED OPEN COLLECTOR CONNECTIONS (NEMA 4)

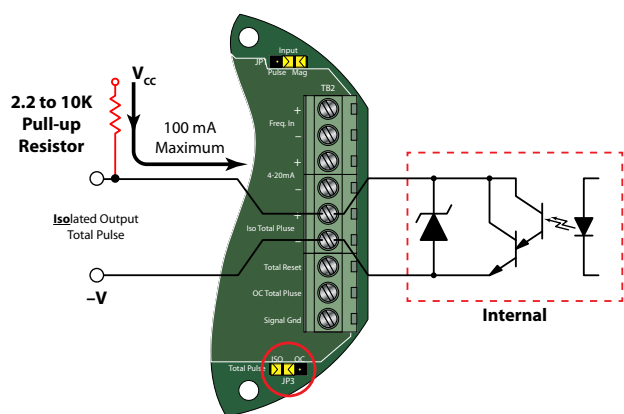

FIGURE 22 - OPTO-ISOLATED OPEN COLLECTOR CONNECTIONS (EX-PROOF)

Both outputs have a maximum current capacity of 100 mA and **require** a “pull-up” resistor. The value of the pull-up resistor is dependent on the supply voltage and the maximum current required by the load device.

FLOW 20 mA (FI=20mA)

Basic Function

When the display is operated using loop power, the flow rate that corresponds to 20 mA must be set. This setting normally represents the maximum rate of the flow sensor connected to the display but other entries are possible.

At the Flow at 20 mA (**FI=20mA**) prompt, press the **ENTER** key once. The current setting will begin to flash. If the current setting is correct, press the **ENTER** key to advance to the next parameter.

If the current setting requires a change, use the **▲** arrow key, increment the display digit until it matches the first digit of the desired maximum flow value. Next press the **▶** arrow key to advance to the next digit and using the **▲** arrow key, increment the second display digit until it matches the second digit of the desired value. Repeat this step until the maximum flow at 20 mA is entered. Press **ENTER** once to save the new flow value.

4-20 mA CALIBRATION (4-20Cal)

Extended Function

This menu item allows the fine adjustment of the **D**igital to **A**nalog **C**onverter (DAC) that controls 4-20 mA output. The 4-20 mA output is calibrated at the factory and under most circumstances does not need to be adjusted. If the output needs to be adjusted for whatever reason the 4-20 mA calibration procedure can be used.

The DAC used in the B3000 is an 12 bit device so the valid entries range from 0 to 4095.

4 mA ADJUSTMENT (4mA Out) – To set the 4 mA value, connect an ammeter in series with the loop power supply as shown in **Figure 14**. At the 4-20Cal prompt, press **ENTER** once. The display will now show a steady **NO** indication. Press the **▲** arrow key to change to a **YES** display and then press enter. The 4 mA DAC setting is typically between 35 and 50. Using the **▲** and **▶** arrow buttons while monitoring the ammeter, adjust the 4 mA value to obtain a 4 mA reading on the ammeter. The **▲** arrow key increases the DAC value and the **▶** arrow key decreases the DAC value. When a steady 4 mA reading is obtained on the ammeter, press the **ENTER** key to lock in this value and move to the 20 mA adjustment.

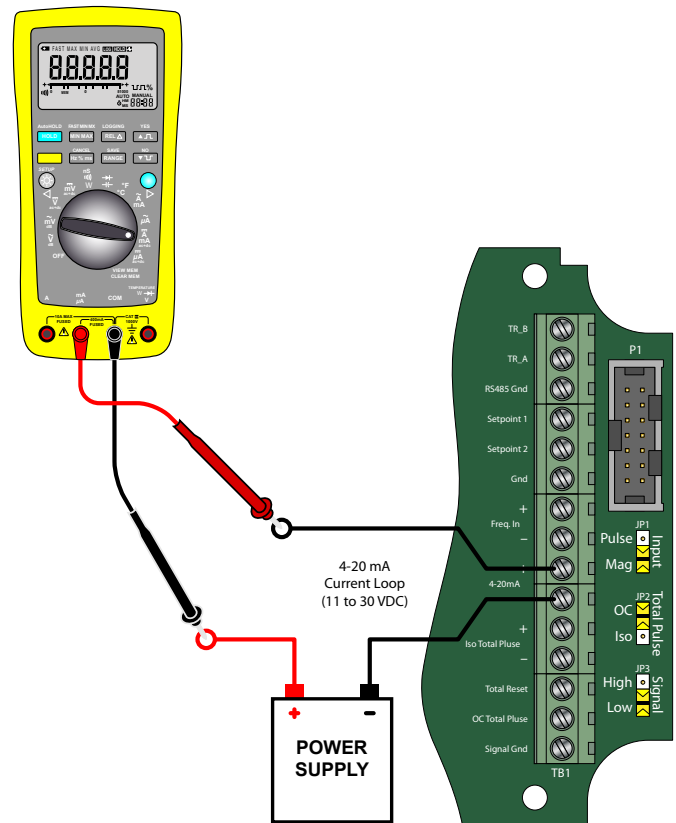

FIGURE 23 - 4-20 MA CALIBRATION SETUP

20 mA ADJUSTMENT (20mAOut) – The 20 mA adjustment is performed using the same procedure as the 4 mA adjustment. While monitoring the ammeter, adjust the 20 mA DAC value to obtain a 20 mA reading. The ▲ arrow key increases the DAC value and the ► arrow key decreases the DAC value. When a steady 20 mA reading is obtained on the ammeter, press the **ENTER** key to lock in this value and move to the next parameter.

4-20 mA TEST (4-20Tst) – The B3000 monitor contains a diagnostic routine that allows the simulation of mA output values between 4 and 20 to check output tracking. At the 4-20 TEST prompt the current is shown as a flashing number. Use the ▲ arrow key to increase the simulated mA output in increments of 1 mA. The ► arrow key will decrease the mA output. The ammeter should track the simulated mA output. If a 4-20 mA test is not necessary, press the **ENTER** key once to move to the next parameter.

NOTE: Pressing the **ENTER** key when the monitor is in test mode will exit the test mode and move on to the next programming parameter.

LINEARIZATION (Linear) Extended Function

Enhanced accuracy can be obtained by linearization of the display. The linearization function will accept a maximum of ten points. Linearization requires additional calibration data from the meter to be used with the monitor. Typically, calibration information can be obtained in three, five, and ten points from the flow meter's manufacturer. If linearization is not needed, press the ► arrow key to advance to the next parameter. The maximum number of linearization points is 10.

Number of Points – At the Linear (**Linear**) prompt, press **ENTER** once. The Linear Points (**Lin Pts**) value will be displayed. If the number of points is set to 0, linearization is disabled. Press **ENTER** and the most significant digit of the number of points entry will begin to flash. The first number can either be a 1 or a 0 only. Use the ▲ arrow key to change the first digit. Press the ► arrow key once to move to the least significant digit.

NOTE: if a number other than 0 or 1 is entered in this field the display will flash Limit (Limit) indicating that an over range value has been entered when Enter is pressed.

Again, the ▲ arrow key increments the value. When the number of points has been input, press the **ENTER** key once to move to the first linear points frequency entry.

Data Entry

NOTE: If the number of linear points is set to 1 the B3000 assumes the user is entering the maximum frequency and coefficient. Further the meter assumes that the implied first point is at a frequency of 0 (zero) and a coefficient of 0 (zero).

Frequency - Press the **ENTER** key once and the first linear point's frequency input (**Freq#1**) will begin to flash. Enter the frequency for the first linear point using ▲ arrow key to increment the numerical values and the ► arrow key to change the position of the number being entered. When the frequency value input is complete, press **ENTER** once again to change to the coefficient value (**Coef#1**) for the first linear point.

Coefficient – The coefficient is the value applied to the nominal K-factor to correct it to the exact K-factor for that point. The coefficient is calculated by dividing the actual K-factor for that point by the Average (Nominal) K-factor for the flow meter.

$$\text{Linear Coefficient} = \frac{\text{Actual K-Factor}}{\text{Nominal K-Factor}}$$

At the Coefficient (**Coef#1**) prompt, enter the coefficient that corresponds to the frequency value previously entered. Press **ENTER** once to move to the scaling point.

Continue entering pairs of frequency and coefficient points until all data has been entered. Press the **ENTER** key to move to the next parameter.

NOTE: The frequency values must be entered in ascending order. If a lower frequency value is entered after a higher value the B3000 will flash Limit followed by the minimum frequency value acceptable to the display.

Example:

The following is actual data taken from a 1 inch turbine flow sensor calibrated with water.

Unit Under Test (UUT) Calibration Data Table In GPM					
Actual GPM	UUT Frequency	UUT Actual K-Factor	(Hz x 60) Nominal K	Linear Coefficient	Raw Error
	Hz	Counts/Gallon	GPM		% Rate
50.02	755.900	906.72	49.72	1.0060	0.59
28.12	426.000	908.96	28.02	1.0035	0.35
15.80	240.500	913.29	15.82	0.9987	-0.13
8.88	135.800	917.57	8.93	0.9941	-0.59
4.95	75.100	910.30	4.94	1.0020	0.20
Nominal K (NK)		912.144			

TABLE 2 - SAMPLE LINEARIZATION DATA

In this example the linear coefficient has already been calculated by the calibration program so all that is required is to enter 5 into the number of linear points (**Lin Pts**) parameter and then enter, in order, the five frequency, linear coefficient data pairs.

MODBUS (Modbus) ***Extended Function***

The Modbus Output parameter can be either **Enabled** or **Disabled**. When enabled, this output allows communications with the B3000 using the Modbus RTU protocol. For additional information see **Modbus** in the Appendix of this manual.

At the Modbus prompt (**Modbus**), press the **ENTER** key once. The current state of the Modbus output will be shown. If the current state is correct, press the **ENTER** key to advance to the next parameter.

If the current state requires a change, use either the **▲** or **▶** arrow buttons to toggle between state. When the proper state has been selected press **ENTER**.

BUS ADDRESS (BusAddr) - If the Modbus output has been enabled a valid Modbus address must also be chosen. Every device communicating over the RS485 communications bus using the Modbus protocol must have a unique bus address. Address values range from 0 to 127 with 0 being the default.

At the Bus Address (**BusAddr**) prompt, press the **ENTER** key once. The current setting will begin to flash. If the current setting is correct, press the **ENTER** key to advance to the next parameter.

If the current setting requires a change, use the **▲** arrow key, increment the display digit until it matches the first digit of the desired bus address. Next press the **▶** arrow key to advance to the next digit and using the **▲** arrow key, increment the second digit until it matches the second digit of the desired address. Repeat this step for the third digit of the address and then press **ENTER** once to save the new address and advance to the next parameter.

SETPOINTS

Setpoints allow the meter to signal when a specific flow condition has been achieved. They are commonly used to indicate high or low flow conditions that need to be attended to. The B3000 has two open collector outputs controlled by the setpoint function.

The setpoint transistors have the same current limitations and setup requirements as the totalizing pulse output transistors described previously (See **Figure 24 & 25**).

Both Setpoint 1 and Setpoint 2 are configured using the same procedures but the hysteresis and tripping conditions can be different for each setpoint output.

NOTE: In most instances the current capacity of an open collector transistor is not sufficient to operate old style counters that relied on relay contact closures. When used with basic counting circuits a solid state relay will most likely be needed.

SETPOINT 1 (SetPt 1) Extended Function

The setpoint is the flow value at which the output transistor changes state. It is set using the same units as the rate units are entered.

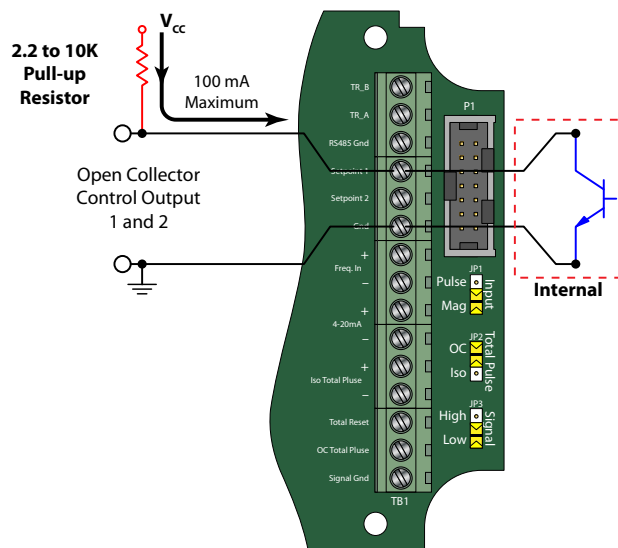

FIGURE 24 - SETPOINT OUTPUT (NEMA 4)

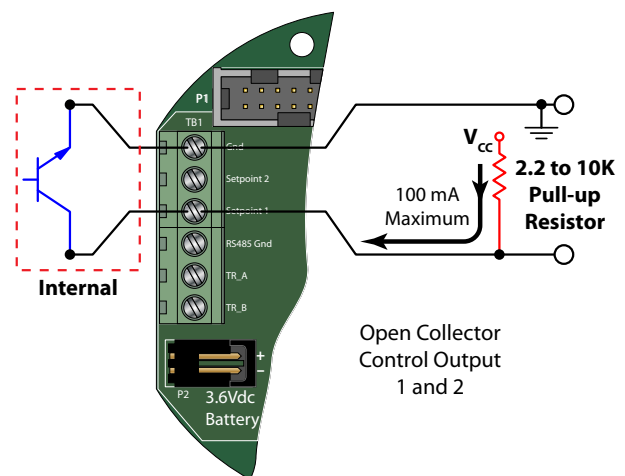

FIGURE 25 - SETPOINT OUTPUT (EX-PROOF)

At the Setpoint 1 (**SetPt 1**) prompt, press the **ENTER** key once. The most significant digit of the current setting will begin to flash. If the current setting is correct, press the **ENTER** key to advance to the next parameter.

If the current setting requires a change, press the **▶** arrow key to advance to the first digit of the desired setpoint value. Once the correct place is reached use the **▲** arrow key to increment the digit until it matches the first number of the desired setpoint. Use the **▶** arrow key to advance to the next digit of the desired setpoint value then use the **▲** arrow key, increment the display digit until it matches the next digit of the desired setpoint. Repeat this step for the all the digits of the setpoint and then press **ENTER** once to save the new setpoint and advance to the next parameter.

HYSTERESIS 1 (HystSP1)

Extended Function

Hysteresis is used to modify how the output transistor reacts around a setpoint by taking recent history into account. Hysteresis prevents an output from turning on and off rapidly when the programmed flow rate is at or very near the setpoint.

For example, a low flow alarm is set to activate when the flow falls below a pre programmed point. When the flow is reduced to the setpoint, even minute changes of flow above the setpoint will turn the output off disabling the alarm. Without hysteresis, if the flow rate fluctuates slightly above and below the setpoint the output will rapidly cycle between on and off states.

Another example is a thermostat controlling a heater. The thermostat turns the heater on when the temperature drops below "A" degrees, but won't turn it off until the temperature rises above "B" degrees. The temperature between "A" and "B" is know as the hysteresis. Thus the on/off output of the thermostat to the heater when the temperature is between "A" and "B" depends on the "history" of the temperature. This prevents rapid switching on and off as the temperature drifts around the setpoint.

Refer to the graphical representation of the hysteresis setting as shown in **Figure 26**. The hysteresis value is set using the same units as the rate units are entered.

At the Hysteresis (**HystSP1**) prompt, press the **ENTER** key once. The most significant digit of the current setting will begin to flash. If the current setting is correct, press the **ENTER** key to advance to the next parameter.

If the current setting requires a change, press the **▶** arrow key to advance to the first digit of the desired hysteresis value. Once the correct place is reached use the **▲** arrow key to increment the digit until it matches the first number of the desired hysteresis. Use the **▶** arrow key to advance to the next digit of the desired hysteresis value then use the **▲** arrow key, increment the display digit until it matches the next digit of the desired hysteresis. Repeat this step for the all the digits of the hysteresis and then press **ENTER** once to save the new hysteresis and advance to the next parameter.

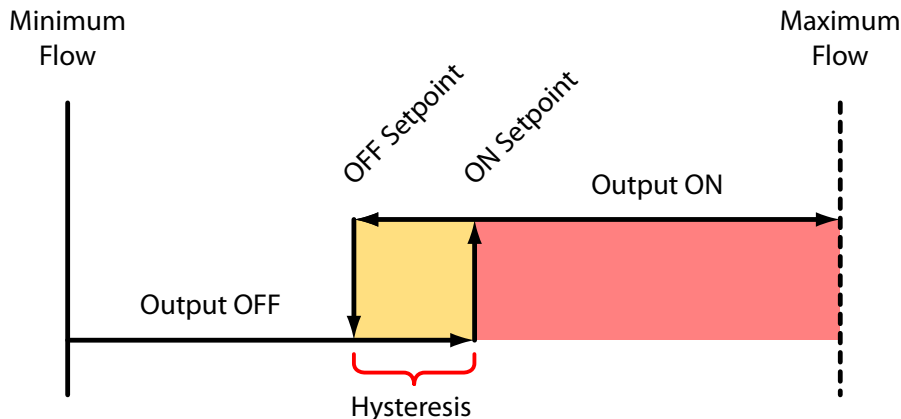

FIGURE 26 - SETPOINT ACTIONS

NOTE: Neither the Setpoint nor the Hysteresis values are checked against the meter size to see if they are appropriate. Care should be used when entering these values, especially in critical applications, as it is possible to enter inappropriate values preventing the outputs from working as expected.

TRIP SP 1 (TripSP1) Extended Function

The Trip parameter can be set for either High (**High**) or Low (**Lo**). When set to high the open collector transistor stops conducting and sends the output high when the setpoint is reached. The output will not go low again until the flow rate falls below the setpoint minus the hysteresis value. Similarly when set to low the, open collector transistor starts conducting sending the output low when the setpoint is reached. The output will not go high again until the flow rate exceeds the setpoint plus the hysteresis value.

For example if the setpoint is set to 10 GPM, the hysteresis is set to 2 GPM and the trip SP is set to high (See **Figure 26**). When the flow goes above 10 GPM the OC transistor will stop conducting and the output will go high. The output will stay high until the flow rate drops below 8 GPM which is the setpoint (10 GPM) minus the hysteresis (2 GPM).

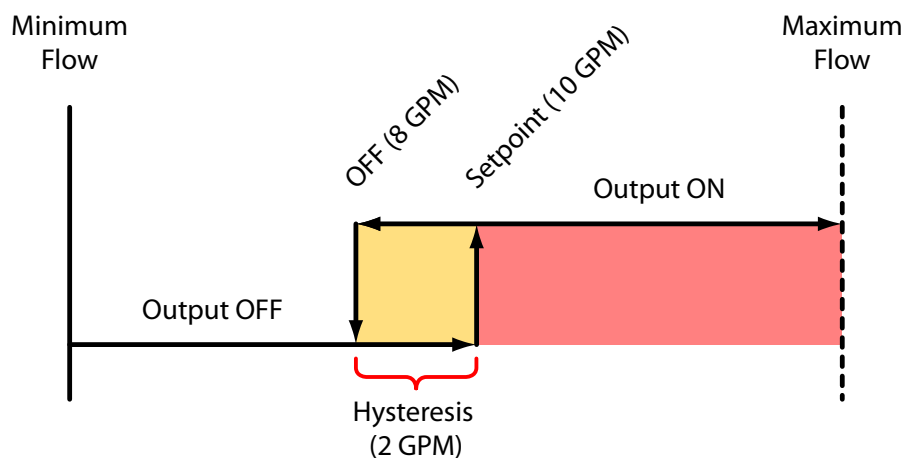

FIGURE 27 - SETPOINT EXAMPLE

At the Trip Setpoint 1 (**TripSP1**) prompt, press the **ENTER** key once. The tripping condition setting will be displayed. If the current setting is correct, press the **ENTER** key to advance to the next parameter.

If the current setting requires a change, press the **▶** arrow key to advance to the alternate choice. Once the correct choice is displayed, press **ENTER** key once to save the new trip condition and advance to the next parameter.

CLEAR GRAND TOTAL (Clr G-T) Basic Function

At the Clear Grand Total (**Clr G-T**) prompt, press the **ENTER** key once. The display will now say **no** on the screen. To clear the grand total press either the **▲** arrow or the **▶** arrow key to change from **no** to **yes**. Press the **ENTER** key to select **yes** and advance to the next parameter.

The totalizer can also be reset using a hardware reset as shown in the following diagrams.

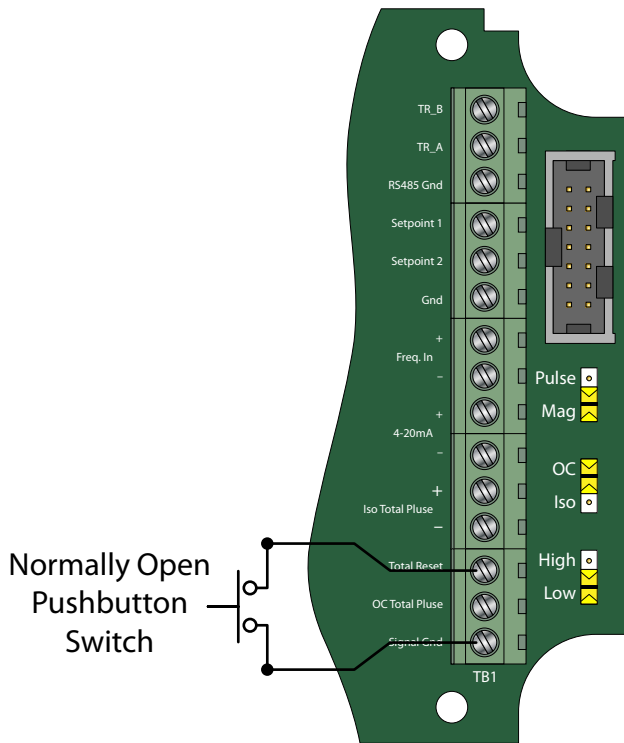

FIGURE 28 - NEMA 4 HARDWARE RESET

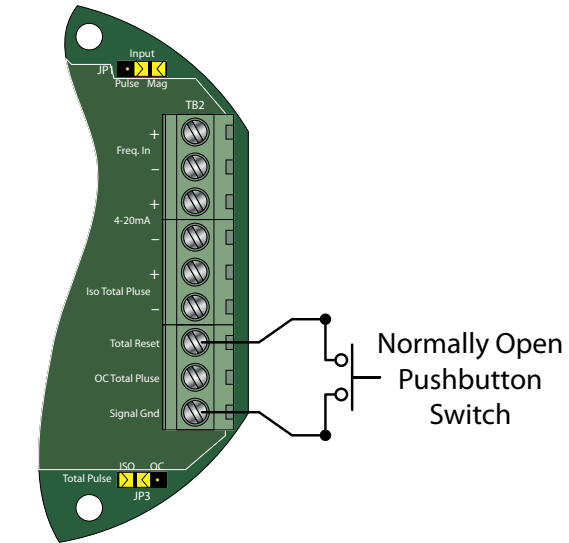

FIGURE 29 - EX-PROOF HARDWARE RESET

PASSWORD (Passwd)

Basic Function

Password protection prevents unauthorized users from changing programming information. Initially, the password is set to all zeros. If the current setting requires a change, press **ENTER** once at the Password (**Passwd**) prompt. The first digit of the password will begin to flash. Use the **▲** arrow key to increment the digit until it matches the first number of the desired password. Use the **▶** arrow key to advance to the next digit of the desired password value then use the **▲** arrow key to increment the display digit until it matches the next digit of the desired password. Repeat this step for the all the digits of the password and then press **ENTER** once to save the new password and advance to the next parameter.

RESET PASSWORD (RstPswd)

Basic Function

Reset password parameter prevents unauthorized users from manually resetting the flow monitor's main totalizer. Initially, the password is set to all zeros. To change the reset password, press **ENTER** once at the reset password prompt. The first digit of the password will begin to flash. Use the **▲** arrow key to increment the digit until it matches the first number of the desired password. Use the **▶** arrow key to advance to the next digit of the desired password value then use the **▲** arrow key to increment the display digit until it matches the next digit of the desired password. Repeat this step for the all the digits of the password and then press **ENTER** once to save the new password and advance to the next parameter.

NOTE: Entering a Passwd in the password screen and leaving the password blank in the RstPswd screen allows for total resets (not requiring a password), but restricts programming modification.

APPENDIX

TROUBLESHOOTING GUIDE

Trouble		Remedy
No LCD Display	Battery	<ul style="list-style-type: none"> Check battery voltage. Should be 3.6 VDC. Replace if low or bad.
	Loop Power	<ul style="list-style-type: none"> Check 4-20 mA input. Voltage must be within the minimum and maximum supply voltage and capable of supplying enough current to run the display. The input voltage is checked "across" or in parallel with the 4-20 mA terminals and current is checked with the ammeter in series with the 4-20 mA output.
	Solar	<ul style="list-style-type: none"> Place meter with solar cell exposed to a strong light source for 24 hours.
No Rate or Total Displayed		<ul style="list-style-type: none"> Check connection from meter pick-up to display input terminals. Check turbine meter rotor for debris. Rotor should spin freely. Check programming of flow monitor.
Flow Rate Display Interprets Reading Constantly		<ul style="list-style-type: none"> This is usually an indication of external noise. Keep all AC wires separate from DC wires. Check for large motors close to the meter pick-up. Check for radio antenna in close proximity. Try disconnecting the pick-up from the monitor pig tail. This should stop the noise.
Flow Rate Indicator Bounces		<ul style="list-style-type: none"> This usually indicates a weak signal. Replace pick-up and/or check all connections. Examine K-factor.

DEFAULT K-FACTOR VALUES

Liquids			
Meter Bore Size	Default K-factor	Lower Limit	Upper Limit
0.375	20,000	16,000	24,000
0.500	13,000	10,400	15,600
0.750	2,750	2,200	3,300
0.875	2,686	2,148	3,223
1.000	870.0	696.0	1,044
1.500	330.0	264.0	396.0
2.000	52.0	41.6	62.0
3.000	57.0	45.6	68.0
4.000	29.0	23.2	35.0
6.000	7.0	5.6	8.0
8.000	3.0	2.4	4.0
10.000	1.6	1.3	2.0

TABLE A1 - LIQUID K-FACTORS

Gas	
Meter Range	Default K-factor
Low	325
Medium	125
High	80

TABLE A2 - GAS K-FACTORS

BATTERY REPLACEMENT

Battery powered monitors use a single 3.6 V, "D" size, lithium battery . When replacement is necessary, use a clean fresh battery to ensure continued trouble-free operation.

Replacement Batteries	
Manufacturer	Part Number
Blancett	B300028
Xeno	S11-0205-10-03
Tadiran	TL-5930/F

NEMA 4 ENCLOSURE

Unscrew the four captive screws on the front panel to gain access to the battery. Press the tab on the battery connector to release it from the circuit board. Remove the old battery and replace it with new one and then re-fasten the front panel.

The solar powered variation uses a single nickle-cadmium battery and is not field replaceable.

EXPLOSION PROOF ENCLOSURE



Danger: Remove (De-Energize) any external power from the unit before removing the screw cover from the enclosure. Failure to do so can be dangerous. (See **Figures 30 & 31**)

- 1) Remove the screw cover from the enclosure body.
- 2) Remove the two thumb screws and carefully remove the circuit board assembly far enough to access the battery connector.
- 3) Press the tab on the battery connector plug to release it from the battery connector socket.
- 4) Remove the four screws holding the battery mounting plate to the enclosure base and then remove the battery mounting plate
- 5) Cut the tie wrap holding the battery to the mounting plate and remove the worn-out battery.
- 6) Install a new tie wrap and battery securing the battery to the mounting plate with the tie wrap.
- 7) Re-install the battery mounting plate.
- 8) Plug the battery into the circuit board and re-install the circuit assembly into the explosion proof housing using the thumb screws.
- 9) Re-install the enclosure screw cover.

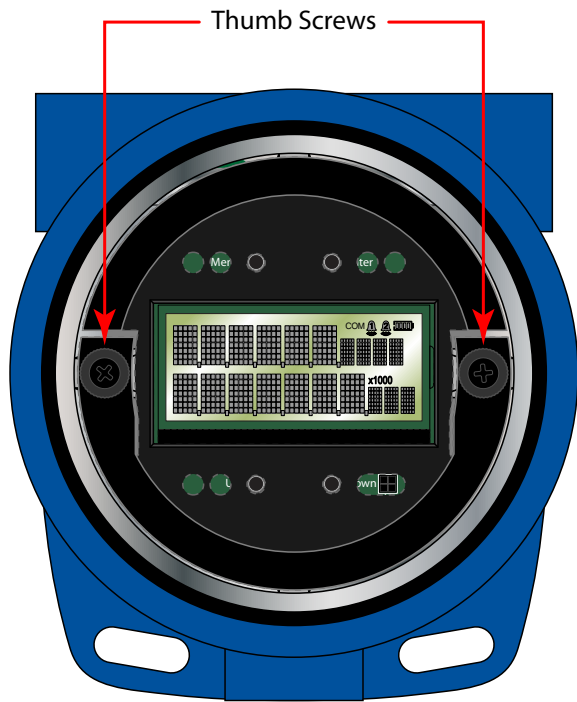

FIGURE 30 - CIRCUIT BOARD REMOVAL

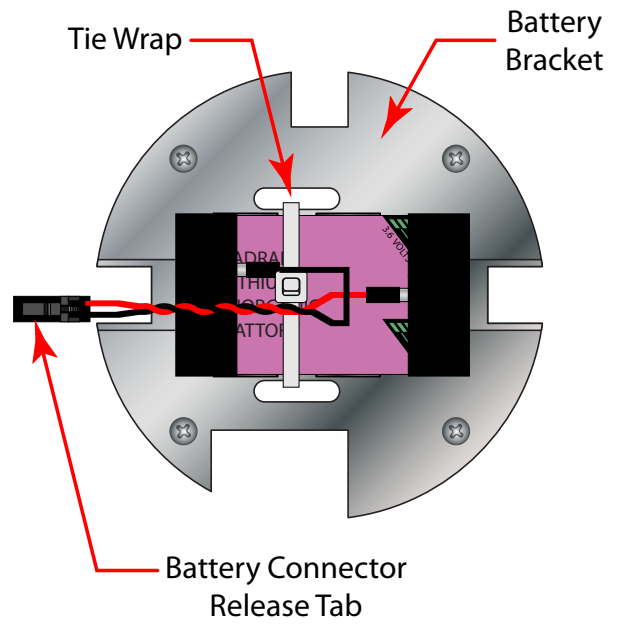

FIGURE 31 - BATTERY REPLACEMENT PARTS IDENTIFICATION

SPECIFICATIONS

Display	
Common:	Simultaneously shows Rate and Total 5 x 7 Dot Matrix LCD, STN Fluid
B30A/B/S:	6 Digit Rate, 0.5 inch (12.7 mm) numeric 7 Digit Total, 0.5 inch (12.7 mm) numeric Engineering Unit Labels 0.34 inch (8.6 mm)
B30X/Z:	6 Digit Rate, 0.37 inch (9.4 mm) numeric 7 Digit Total, 0.37 inch (13 mm) numeric Engineering Unit Labels 0.24 inch (6.1 mm)
Annunciators:	Alarm 1 (A), Alarm 2 (A), Battery Level (A), RS485 Communications (COM)
Power	
B30A/B/X/Z:	Auto switching between internal battery and external loop power; B30A/Z includes isolation between loop power and other I/O Battery: 3.6 V lithium "D Cell" gives up to 6 years of service life. Loop: 4-20 mA, two wire, 25 mA limit, reverse polarity protected, 7 VDC loop loss
B30S:	Internal battery (3.6 V Nicd) provides up to 30 days of power after 6-8 hours exposure of the integrated photovoltaic cell to direct sunlight.
Inputs	
Magnetic Pickup:	Frequency Range: 1 to 3,500 Hz Frequency Measurement Accuracy: ±0.1% Over Voltage Protection: 28 VDC Trigger Sensitivity: 30 mV _{p-p} (High) or 60 mV _{p-p} (Low) - (selected by circuit board jumper)
Amplified Pulse:	Direct connection to amplified signal (pre-amp output from sensor)
Outputs	
Analog 4-20 mA:	4-20 mA, two-wire current loop 25 mA current limit
Totalizing Pulse:	One pulse for each Least Significant Digit (LSD) increment of the totalizer Pulse Type: (selected by circuit board jumper) Opto-isolated (Iso) open collector transistor Non-isolated open drain FET Maximum Voltage: 28 VDC Maximum Current Capacity: 100 mA Maximum Output Frequency: 16 Hz Pulse Width: 30 mSec fixed
Status Alarms - B30A/Z:	Type: Open collector transistor Adjustable flow rate with programmable dead band and phase. Maximum Voltage: 28 VDC Maximum Current: 100 mA Pull-Up Resistor: External required (2.2 K Ohm minimum, 10 K Ohm maximum)
Status Alarms - B30B/S/X:	None
Modbus Digital Communications	
B30A/Z:	Modbus RTU over RS485, 127 addressable units / 2-wire network, 9600 baud, long integer and single precision IEEE754 formats; retrieve: flow rate, job totalizer, grand totalizer, alarm status and battery level; write: reset job totalizer, reset grand totalizer
B30B/S/X:	None

Data Configuration and Protection	
B30A/B/X/Z:	Two 4-digit user selectable passwords; level one password enables Job Total reset only, level two password enables all configuration and totalizer reset functions (Not Applicable on solar powered units)
Totalizer Operation	
Common Functions:	Monitors contain two totalizers: Job and Grand. The user can enable/disable the Grand Totalizer function. If Grand Totalizer is enabled, it shares the 7-digit display line with the Job Totalizer – dwelling between Job and Grand. Grand Totalizer rollovers are displayed with a Count value that increments at each rollover. Totalizers are automatically backed up into non-volatile FLASH memory every 20 minutes and prior to battery expiration; manually via keypad or when signaled via Modbus (B30A and B30Z only).
Totalizer Reset:	B30A/B/S only: The Job Totalizer can be reset by momentarily contacting the Total Reset terminal to ground or pressing the MENU and ENTER buttons simultaneously. The Grand Totalizer can be reset via selection in the Advanced Menu or Modbus. (Modbus not applicable on solar powered units)
	B30X/Z: *The Job Totalizer can be reset via the “through the glass” touch sensor, by momentarily contacting the Total Reset terminal to ground or pressing the MENU and ENTER buttons simultaneously. The Grand Totalizer can be reset via selection in the Advanced Menu or Modbus command.
Totalizer Preset:	User can preset Job Total values
Certifications	
Safety:	B30A/B/S only: Class I Div 1 Groups C,D (Class I Zone 0, IIB); Class II, III, Div 1 Groups E,F,G T4 to UL 913 Fifth Edition and CSA C22.2 No. 157 Complies with Directive 94/9/EC to ATEX II 2 G Ex ib IIB T4 and Directive 2004/108/EC for EMC
	B30X/Z only: Class I Div 1 Groups B,C,D; Class II, III, Div 1, Groups E,F,G T4 to UL 1203 Fourth Edition and CSA C22.2 No. 30-M 1986 (R2003) Complies with Directive 94/9/EC to ATEX II 2 G Ex d IIC T4 Gb / ATEX II 2 D Ex tb IIIC T135 C Db and Directive 2004/108/EC for EMC
Entity Parameters:	B30A/B only: 4-20mA Loop: Vmax=28Vdc, Imax=26mA, Ci=0.5uF, Li=0mH B30A/B/S only: Pulse Output: Vmax=28Vdc, Imax=100mA, Ci=0uF, Li=0mH B30A/B/S only: Reset Input: Vmax=5Vdc, Imax=5mA, Ci=0uF, Li=0mH B30A/B only: RS485: Vmax=10Vdc, Imax=60mA, Ci=0uF, Li=0mH B30A/B/S only: Turbine Input: Voc=3.5V, Isc=3.6mA, Ca=1.5uF, La=1.65H
CE:	Emissions / Susceptibility; Complies with EN 61326-1: 2006
Measurement Accuracy	
Common Accuracy:	0.05%
Response Time (Damping)	
Common Response Time:	1-100 seconds response to a step change input, user adjustable
Environmental Limits	
Common Limits:	-22° to +158° F [-30° to +70° C]; 0-90% humidity, non-condensing;
Materials and Enclosure Ratings	
B30A/B/S:	Polycarbonate, stainless steel, polyurethane, thermoplastic elastomer, acrylic; NEMA 4X/IP 66
B30X/Z:	Copper free, epoxy-coated, aluminum, buna seal, NEMA 4X/IP66

***NOTE:** The “through the glass” touch sensor button is currently under development in the explosion proof version of the B3000.

Engineering Units	
Liquid:	Gallons, Liters, Oil Barrels (42 gallon), Liquid Barrels (31.5 gallon), Cubic Meters, Million Gallons, Cubic Feet, Million Liters, Acre Feet
Gas:	Cubic Feet, Thousand Cubic Feet, Million Cubic Feet, Standard Cubic Feet, Actual Cubic Feet, Normal Cubic Meters, Actual Cubic Meters, Liters
Rate Time:	Seconds, minutes, hours, days
Totalizer Exponents:	0.00, 0.0, X1, x10, x100, x1,000
K-Factor Units:	Pulses/Gallon, Pulse/cubic meter, pulses/liter, pulses/cubic foot

ADVANCED I/O LIQUID

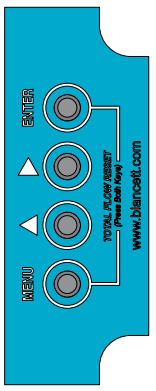
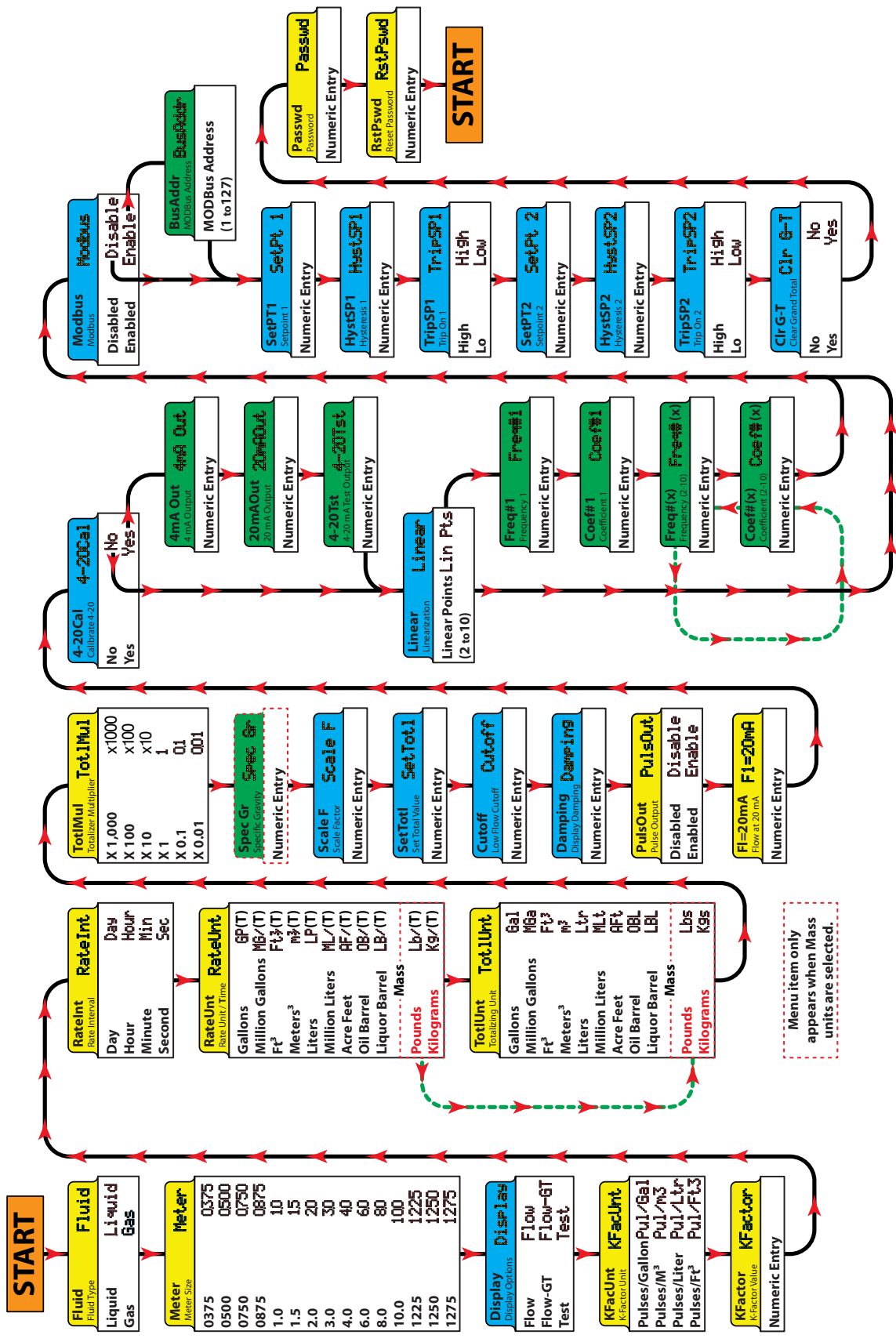

Basic Extended
Sub Menu

Press and Hold **MENU** button for Extended settings

LIQUID

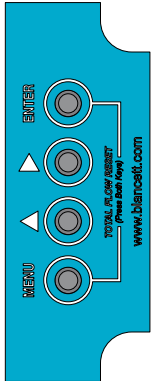
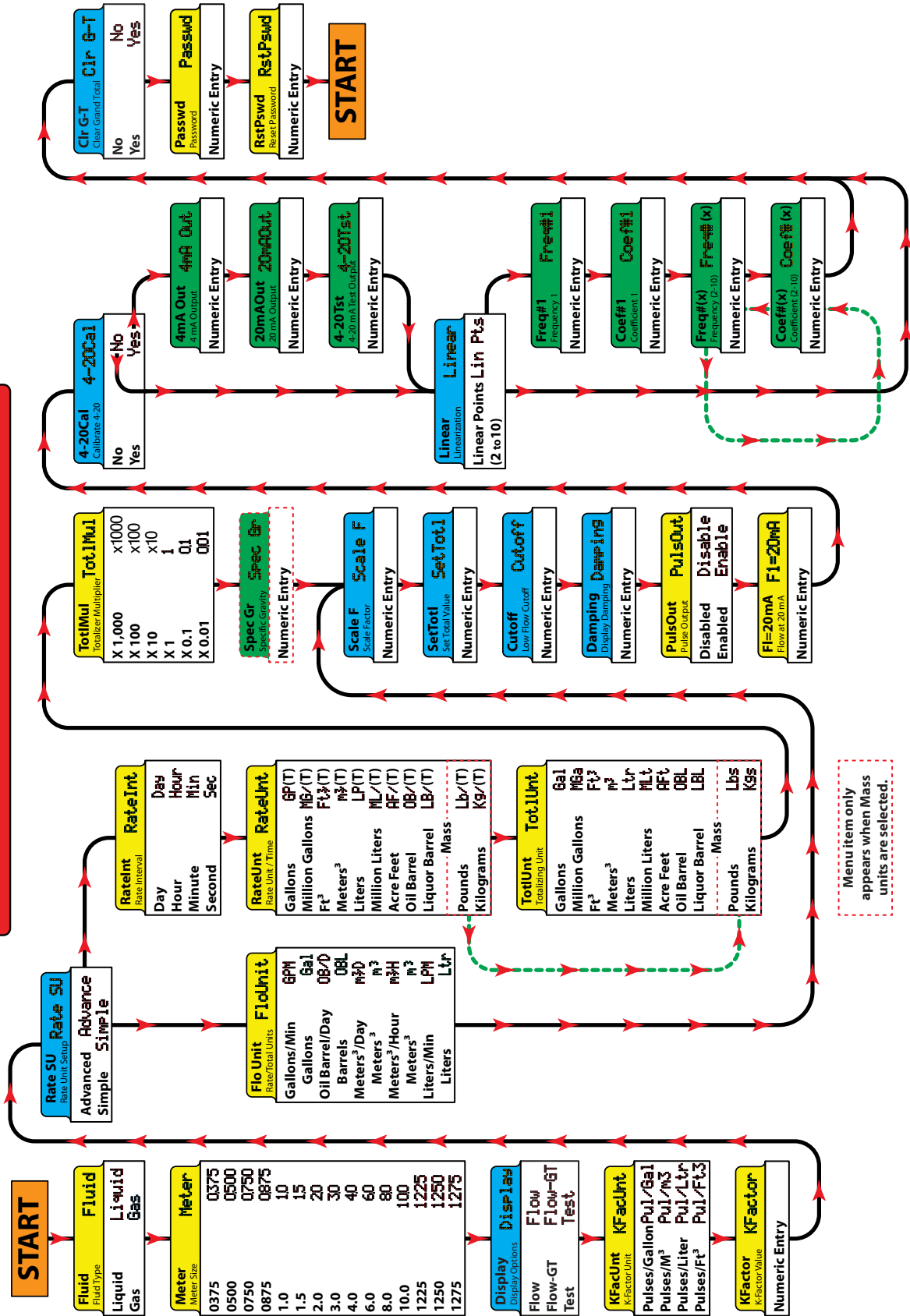

Basic **Extended**
Sub Menu

Press and Hold **MENU** button
for Extended settings

Menu item only
appears when Mass
units are selected.

LIQUID (Solar Powered)

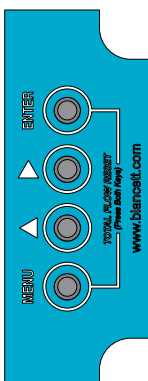
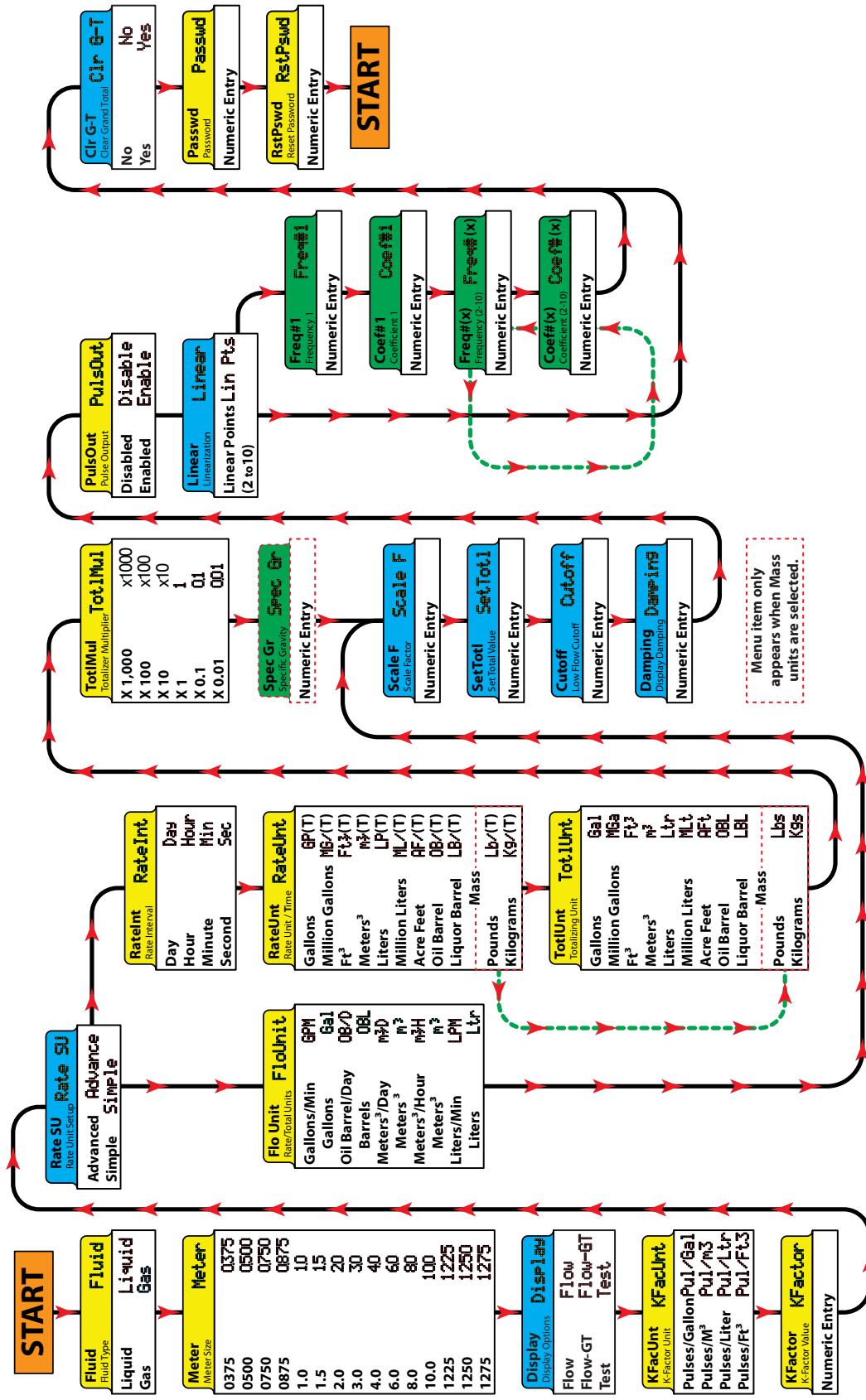

Basic **Extended**

Sub Menu

Press and Hold **MENU** button for Extended settings

GAS

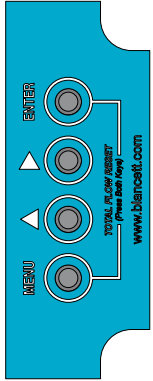
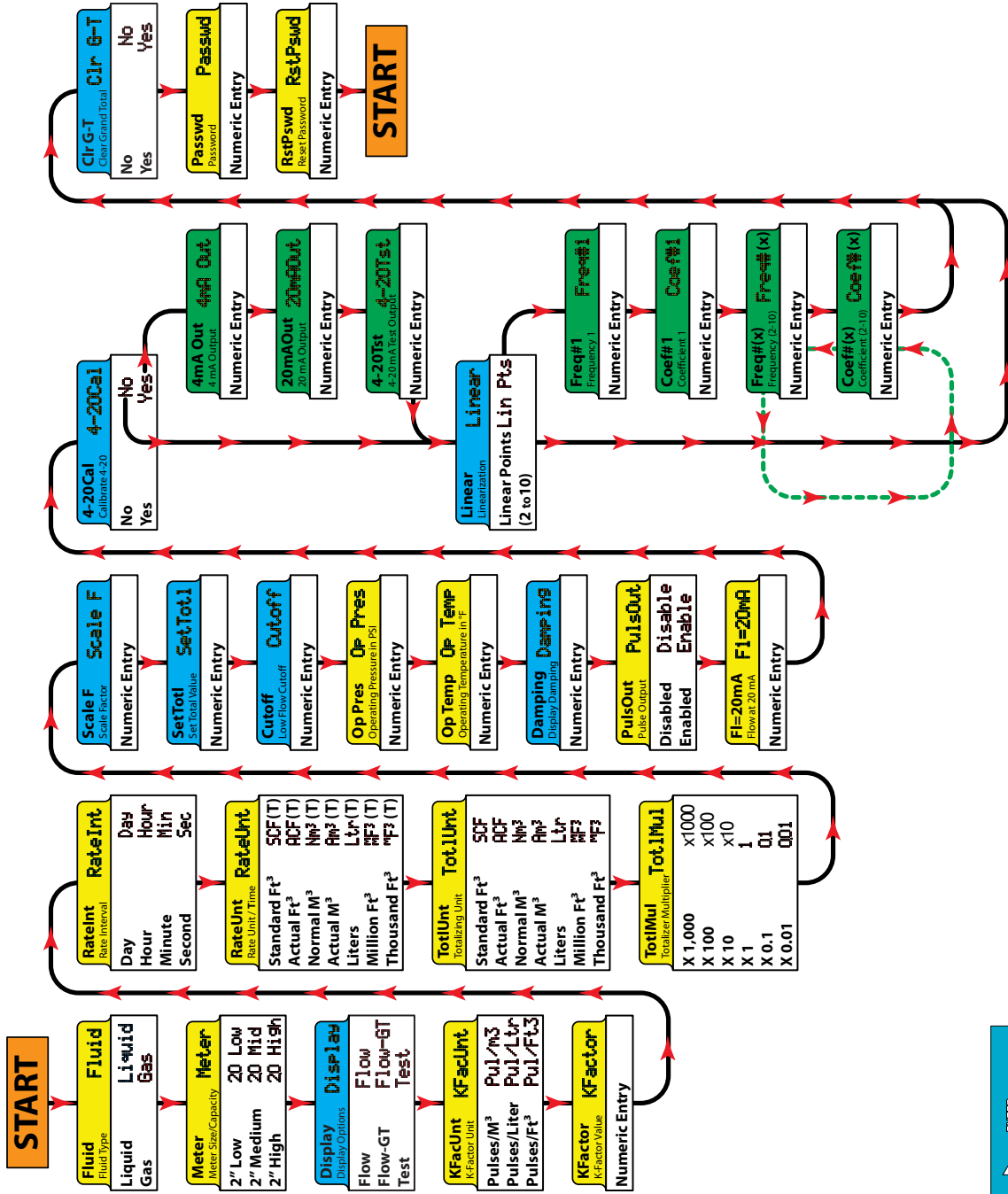

Basic **Extended**

Sub Menu

Press and Hold **MENU** button
for Extended settings

ADVANCED I/O GAS

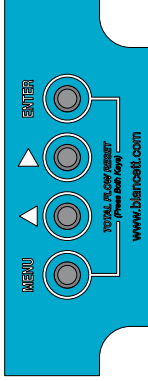
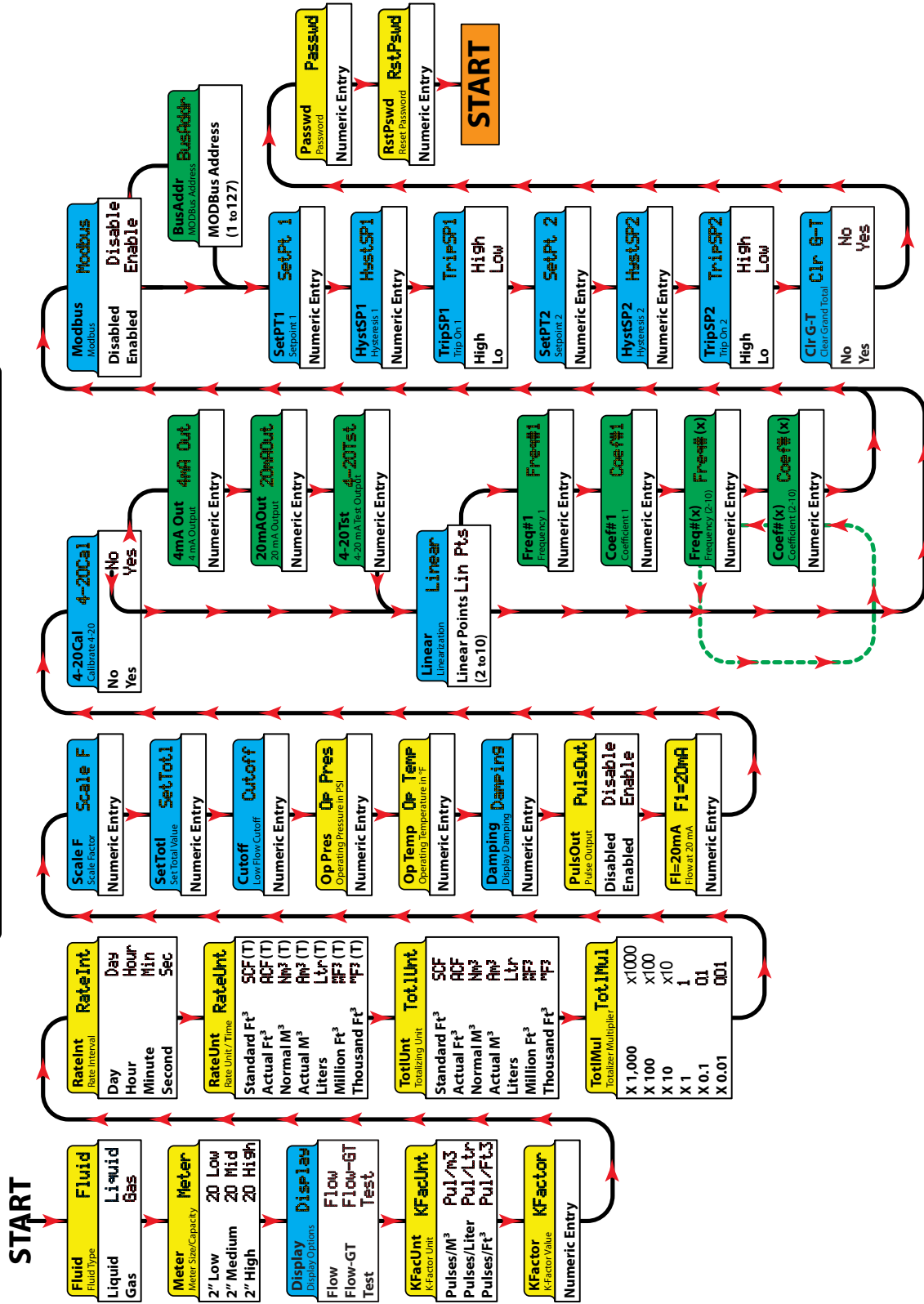

Basic
Extended
Sub Menu

Press and Hold **MENU** button
for Extended settings

GAS (Solar Powered)

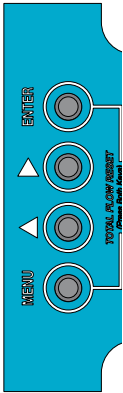
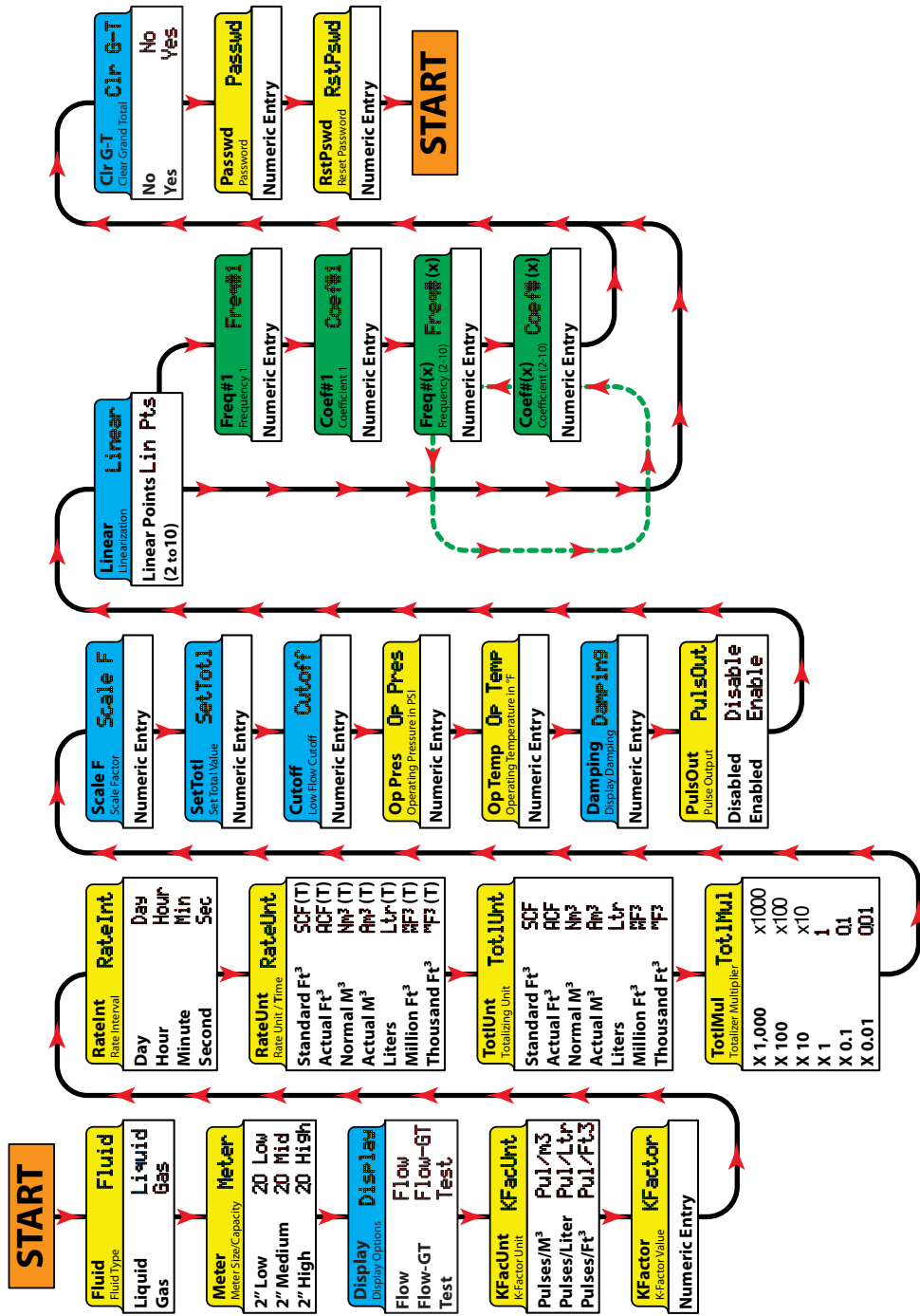

Basic **Extended**

Sub Menu

Press and Hold **MENU** button

K-FACTORS EXPLAINED

The K-factor (with regards to flow) is the number of pulses that must be accumulated to equal a particular volume of fluid. You can think of each pulse as representing a small fraction of the totalizing unit.

An example might be a K-factor of 1000 (pulses per gallon). This means that if you were counting pulses, when the count total reached 1000, you would have accumulated 1 Gallon of liquid. Using the same reasoning, each individual pulse represents an accumulation of 1/1000 of a gallon. This relationship is independent of the time it takes to accumulate the counts.

The frequency aspect of K-factors is a little more confusing because it also involves the flow rate. The same K-factor number, with a time frame added, can be converted into a flow rate. If you accumulated 1000 counts (one gallon) in one minute, then your flow rate would be 1 GPM. The output frequency, in Hz, is found simply by dividing the number of counts (1000) by the number of seconds (60) to get the output frequency.

$1000 \div 60 = 16.6666\dots$ Hz. If you were looking at the pulse output on a frequency counter, an output frequency of $16.666\dots$ Hz would be equal to 1 GPM. If the frequency counter registered $33.333\dots$ Hz ($2 \times 16.666\dots$ Hz), then the flow rate would be 2 GPM.

Finally, if the flow rate is 2 GPM, then the accumulation of 1000 counts would take place in 30 seconds because the flow rate, and hence the speed that the 1000 counts is accumulated, is twice as great.

CALCULATING K-FACTORS

Many styles of flow meters are capable of measuring flow in a wide range of pipe sizes. Because the pipe size and volumetric units the meter will be used on vary, it may not possible to provide a discrete K-factor. In the event that a discrete K-factor is not supplied then the velocity range of the meter is usually provided along with a maximum frequency output.

The most basic K-factor calculation requires that an accurate flow rate and the output frequency associated with that flow rate be known.

Example 1:

Known values are:

Frequency = 700 Hz
Flow Rate = 48 GPM

1) $700 \text{ Hz} \times 60 \text{ sec} = 42,000 \text{ pulses per min}$

2)
$$K - \text{factor} = \frac{42,000 \text{ pulses per min}}{48 \text{ GPM}} = 875 \text{ pulses per gallon}$$

Example 2:

Known values are:

$$\begin{aligned}\text{Full Scale Flow Rate} &= 85 \text{ GPM} \\ \text{Full Scale Output Frequency} &= 650 \text{ Hz}\end{aligned}$$

1) $650 \text{ Hz} \times 60 \text{ sec} = 39,000 \text{ pulses per min}$

2) $K - \text{factor} = \frac{39,000 \text{ pulses per min}}{85 \text{ GPM}} = 458.82 \text{ pulses per gallon}$

The calculation is a little more complex if velocity is used because you first must convert the velocity into a volumetric flow rate to be able to compute a K-factor.

To convert a velocity into a volumetric flow, the velocity measurement and an accurate measurement of the inside diameter of the pipe must be known. Also needed is the fact that 1 US gallon of liquid is equal to 231 cubic inches.

Example 3

Known values are:

$$\begin{aligned}\text{Velocity} &= 4.3 \text{ ft/sec} \\ \text{Inside Diameter of Pipe} &= 3.068 \text{ in}\end{aligned}$$

1) Find the area of the pipe cross section.

$$\text{Area} = \pi r^2$$

$$\text{Area} = \pi \left(\frac{3.068}{2} \right)^2 = \pi \times 2.353 = 7.39 \text{ in}^2$$

2) Find the volume in 1 ft of travel.

$$7.39 \text{ in}^2 \times 12 \text{ in (1ft)} = \frac{88.71 \text{ in}^3}{\text{ft}}$$

3) What portion of a gallon does 1 ft of travel represent?

$$\frac{88.71 \text{ in}^3}{231 \text{ in}^3} = 0.384 \text{ gallons}$$

So for every foot of fluid travel 0.384 gallons will pass.

What is the flow rate in GPM at 4.3 ft/sec?

$$0.384 \text{ gallons} \times 4.3 \text{ FPS} \times 60 \text{ sec (1 min)} = 99.1 \text{ GPM}$$

Now that the volumetric flow rate is known, all that is needed is an output frequency to determine the K-factor.

Known values are:

$$\text{Frequency} = 700 \text{ Hz (By measurement)}$$

$$\text{Flow Rate} = 99.1 \text{ GPM (By calculation)}$$

$$1) 700 \text{ Hz} \times 60 \text{ sec} = 42,000 \text{ pulses per gallon}$$

$$2) K - \text{factor} = \frac{42,000 \text{ pulses per min}}{99.1} = 423.9 \text{ pulses per gallon}$$

SYMBOL EXPLANATIONS



Caution—Refer to accompanying documents.



**WARNING:
EXPLOSION HAZARD - SUBSTITUTION OF COMPONENTS MAY IMPAIR SUITABILITY FOR CLASS I, DIVISION 2.**



**AVERTISSEMENT:
RISQUE D'EXPLOSION - LA SUBSTITUTION DE COMPOSANTS PEUT RENDRE CE MATÉRIEL INACCEPTABLE POUR LES EMPLACEMENTS DE CLASSE I, DIVISION 2.**







**WARNING:
DO NOT CONNECT OR DISCONNECT EITHER POWER OR OUTPUTS UNLESS THE AREA IS KNOWN TO BE NON-HAZARDOUS.**



**AVERTISSEMENT:
RISQUE D'EXPLOSION. NE PAS DÉBRANCHER TANT QUE LE CIRCUIT EST SOUS TENSION, À MOINS QU'IL NE S'AGISSE D'UN EMPLACEMENT NON DANGEREUX.**



**IMPORTANT NOTE:
Not following instructions properly may impair safety of equipment and/or personnel.**

ELECTRICAL SYMBOLS					
Function	Direct Current	Alternating Current	Earth (Ground)	Protective Ground	Chassis Ground
Symbol					

EXPLOSION-PROOF ENCLOSURE

The ExDirect instrument enclosure is designed to house instrumentation and control equipment as well as act as a conduit outlet body in hazardous, abusive and wet locations.

The ExDirect enclosure is approved by:

Agency	Approvals
FM	Explosion-proof for Class I, Division 1, Groups B, C and D; dust ignition-proof for Class II/III, Division 1, Groups E, F and G, hazardous (classified) locations, indoors and outdoors (Type 4X/IP66)
CSA	Explosion-proof for Class I, Division 1, Groups B, C and D; dust ignition-proof for Class II/III, Division 1, Groups E, F and G, hazardous (classified) locations, indoors and outdoors (Type 4X/IP66)
ATEX	II 2 G D, Ex d IIC, Ex tD A21, IP68, Ta = -30 °C to +70 °C
IEC EX	Ex d IIC, Ex A21 tD, IP68, Ta = -30 °C to +70 °C

TABLE A3 - APPROVALS

Installation

1. ExDirect instrument enclosures are furnished with three ¾" NPT offset through-feed cast hubs for conduit entries.
2. Secure the enclosure to the conduit system. If the enclosure has mounting feet, select a mounting location that will provide sufficient strength and rigidity to support the enclosure as well as the enclosed device and wiring.



WARNING: Electrical power must be "OFF" before and during installation and maintenance.



CAUTION: Select a mounting location so that the enclosure will not be subjected to impact by heavy objects. Impacts can damage enclosed devices or glass lens.

3. Install sealing fittings as required by Section 501-5 and/or 502-5 of the National Electrical Code® and Section 18 of the Canadian Electrical Code or any other applicable local codes and when enclosure is installed in Class I Group B hazardous locations. (For CSA Group C applications, unsealed conduit lengths must not exceed 5 ft. or 152 cm.)
4. Un-thread instrument cover and carefully set aside to prevent damage to the cover threads and glass lens.
5. Pull wires into enclosure making certain they are long enough to make the required connections and to remove the instrument or power supply if servicing is required. Install instrument and power supply, if applicable, and make all electrical connections.

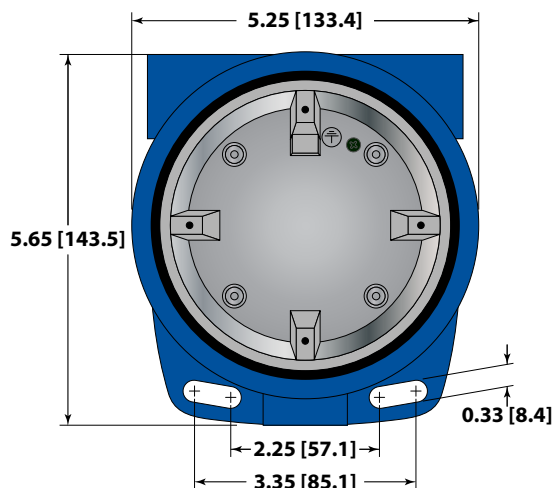

6. Test wiring for correctness by checking continuity and also check for unwanted grounds with insulator resistance tester. Make sure test equipment being used will not damage instrument to be housed in the ExDirect instrument enclosure.

7. Carefully re-thread cover to enclosure housing. Tighten cover until cover flange contacts body face.



WARNING: The hazardous location information specifying class and group listing of each instrument enclosure is marked on the nameplate of each enclosure.



CAUTION: All unused conduit openings must be plugged. Plug unused conduit openings with approved explosion proof plugs. Plugs must be a minimum of 1/8" thick and engage a minimum of 5 full threads.

NOTE: When installing device, be sure to check instrument dimensions to avoid interference with clamping ring on glass lens and the cover on standard units.



CAUTION: Use care to prevent dirt, grit or other foreign material from lodging on threads. If such material settles on threads, clean with kerosene or Stoddard solvent*, then re-lubricate with an approved thread lubricant.

8. Tighten cover set screws to prevent cover from loosening under vibration.



WARNING: To maintain the explosion-proof integrity of the enclosure with a screw in a tapped mounting pad hole, there must be a minimum of 1/16" of material between the drill point and the back wall. If for any reason a screw will not be threaded into the drilled hole, a minimum of 1/8" of material must remain between the drill point and the back wall.

* To avoid the possibility of an explosion, oxidation and corrosion, do not use gasoline or similar solvent.

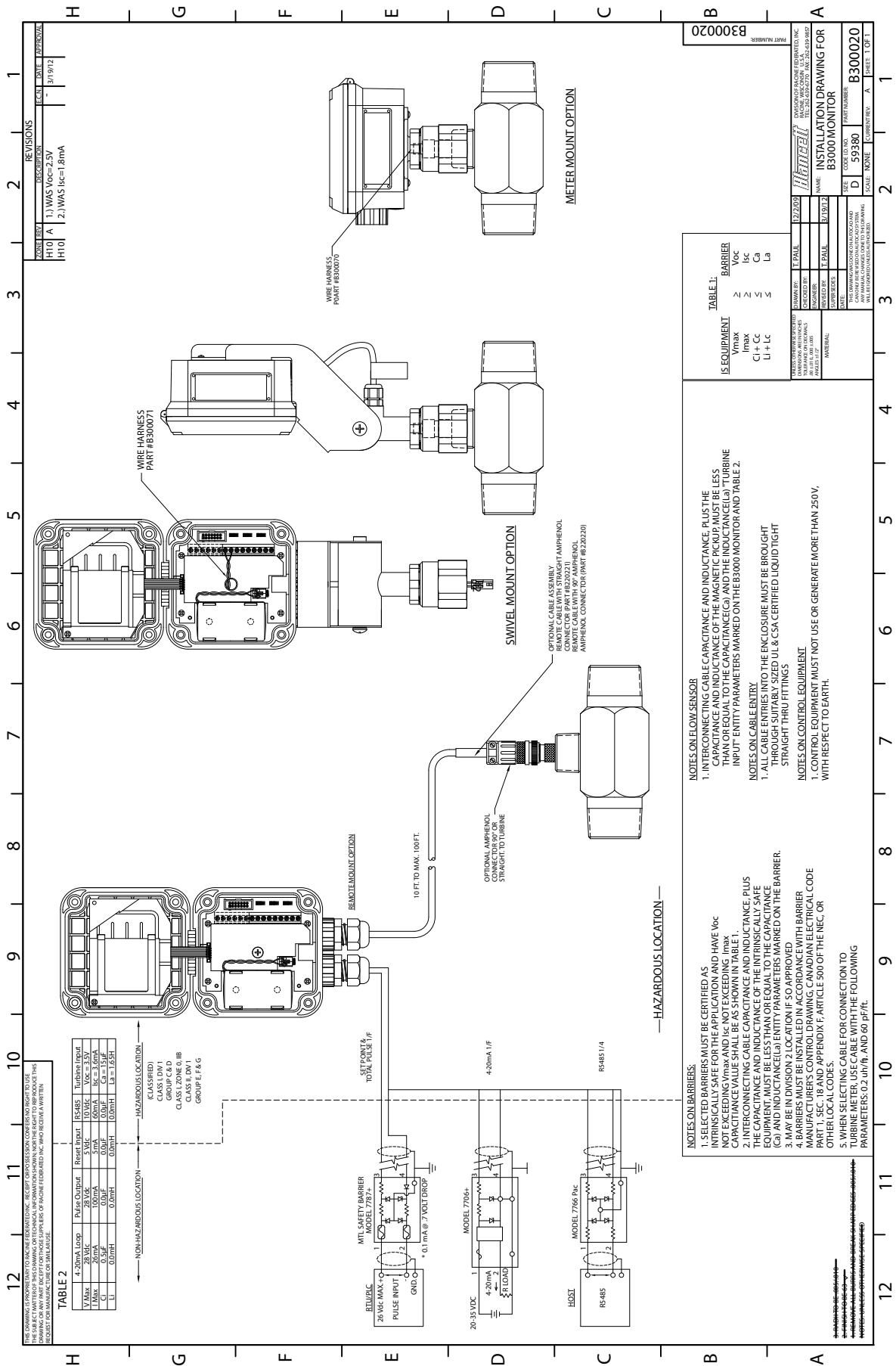

NO.	REV.	DESCRIPTION	DATE
1	H10	1.) WAS VOLT=2.5V	3/19/12
2	H10	2.) WAS Icc=1.8mA	

PARAMETER	4-20mA Loop	Pulse Output	RS485	Turbine Input
V _{max}	28 VDC	3 VDC	V _{oc} = 3.5V	
I _{max}	0.5A	0.5A	C _a = 15 nF	
L _i	0.01mH	0.01mH	L _b = 1.65mH	



IS EQUIPMENT	TABLE 1: BARRIER
max	Voc
I _{max}	I _{cc}
C _a + C _c	C _a
L _i + L _c	L _a

NOTES ON FLOW SENSOR

- INTERCONNECTING CABLE CAPACITANCE AND INDUCTANCE, PLUS THE CAPACITANCE AND INDUCTANCE OF THE MAGNETIC PICKUP, MUST BE LESS THAN OR EQUAL TO THE CAPACITANCE (C_a) AND THE INDUCTANCE (L_a) TURBINE INPUT ENTRY PARAMETERS MARKED ON THE B3000 MONITOR AND TABLE 2.

NOTES ON CABLE ENTRY

- ALL CABLE ENTRIES INTO THE ENCLOSURE MUST BE BROUGHT THROUGH SUITABLY SIZED UL & CSA CERTIFIED LIQUID TIGHT STRAIGHT THRU FITTINGS

NOTES ON CONTROL EQUIPMENT

- CONTROL EQUIPMENT MUST NOT USE OR GENERATE MORE THAN 250V, WITH RESPECT TO EARTH.

NOTES ON BARRIERS:

- SELECTED BARRIERS MUST BE CERTIFIED AS INTRINSICALLY SAFE FOR THE APPLICATION AND HAVE V_{oc} NOT EXCEEDING V_{max} AND I_{cc} NOT EXCEEDING I_{max}.
- INTERCONNECTING CABLE CAPACITANCE AND INDUCTANCE, PLUS THE CAPACITANCE AND INDUCTANCE OF THE INTRINSICALLY SAFE EQUIPMENT, MUST BE LESS THAN OR EQUAL TO THE CAPACITANCE (C_a) AND INDUCTANCE (L_a) ENTRY PARAMETERS MARKED ON THE BARRIER.
- IT MAY BE IN DIVISION 2 LOCATION IF SO APPROVED
- BARRIERS MUST BE INSTALLED IN ACCORDANCE WITH BARRIER MANUFACTURER'S CONTROL DRAWING, CANADIAN ELECTRICAL CODE AND ALL OTHER LOCAL CODES.
- WHEN SELECTING CABLE FOR CONNECTION TO TURBINE METER, USE CABLE WITH THE FOLLOWING PARAMETERS: 0.2 μm/Ft. AND 60 pF/Ft.

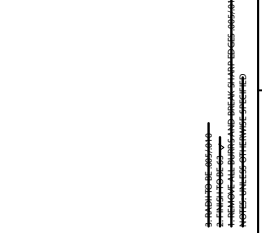

TABLE 1: BARRIER	TABLE 2
DESIGNED BY: T. PAUL	DESIGNED BY: T. PAUL
ENGINEERED BY: T. PAUL	ENGINEERED BY: T. PAUL
DATE: 11/29/10	DATE: 11/29/10

B3000 MODBUS INTERFACE

A subset of the standard Modbus commands is implemented to provide access into the data and status of the B3000 Monitor. This feature is available on the B3000 Advanced models only. The following Modbus commands are implemented:

Command	Description
01	Read Coils
03	Read Holding Registers
05	Force Single Coil

TABLE MB1 - MODBUS COMMANDS

Type	Bits	Bytes	Modbus Registers
Long Integer	32	4	2
Single Precision IEEE754	32	4	2

TABLE MB2 - AVAILABLE DATA FORMATS

MODBUS REGISTER / WORD ORDERING

Each Modbus Holding Register represents a 16-bit integer value (2 bytes). The official Modbus standard defines Modbus as a 'big-endian' protocol where the most significant byte of a 16-bit value is sent before the least significant byte. For example, the 16-bit hex value of '1234' is transferred as '12' '34'.

Beyond 16-bit values, the protocol itself does not specify how 32-bit (or larger) numbers that span over multiple registers should be handled. It is very common to transfer 32-bit values as pairs of two consecutive 16-bit registers in little-endian word order. For example, the 32-bit hex value of '12345678' is transferred as '56' '78' '12' '34'. Notice the Register Bytes are still sent in big-endian order per the Modbus protocol, but the Registers are sent in little-endian order.

Other manufactures, store and transfer the Modbus Registers in big-endian word order. For example, the 32-bit hex value of '12345678' is transferred as '12' '34' '56' '78'. It doesn't matter which order the words are sent, as long as the receiving device knows which way to expect it. Since it's a common problem between devices regarding word order, many Modbus master devices have a configuration setting for interpreting data (over multiple registers) as 'little-endian' or 'big-endian' word order. This is also referred to as swapped or word swapped values and allows the master device to work with slave devices from different manufactures.

If, however, the endianness is not a configurable option within the Modbus master device, it's important to make sure it matches the slave endianness for proper data interpretation. The B3000 actually provides two Modbus Register maps to accommodate both formats. This is useful in applications where the Modbus Master cannot be configured for endianness.

REGISTER MAPPINGS

Data Component Name	MODBUS Registers		Available Units
	Long Integer Format	Single Precision Floating Point Format	
Spare	40100 - 40101	40200 - 40201	-
Flow Rate	40102 - 40103	40202 - 40203	Gallons, Liters, MGallons, Cubic Feet, Cubic Meters, Acre Feet, Oil Barrel, Liquid Barrel, Feet, Meters, Lb, Kg, BTU, MBTU, MMBTU, TON Per <i>Second, Minute, Hour, Day</i>
Spare	40104 - 40105	40204 - 40205	
Positive Totalizer	40106 - 40107	40206 - 40207	
Grand Total Totalizer	40108 - 40109	40208 - 40209	
Battery Voltage	40110 - 40111	40210 - 40211	x.xx
Spare	40112 - 40113	40212 - 40213	

TABLE MB3 - MODBUS REGISTER MAP FOR 'LITTLE-ENDIAN' WORD ORDER MASTER DEVICES

For reference: If the B3000 Totalizer = 12345678 hex
 Register 40106 would contain 5678 hex (Word Low)
 Register 40107 would contain 1234 hex (Word High)

Data Component Name	MODBUS Registers		Available Units
	Long Integer Format	Single Precision Floating Point Format	
Spare	40600 - 40601	40700 - 40701	-
Flow Rate	40602 - 40603	40702 - 40703	Gallons, Liters, MGallons, Cubic Feet, Cubic Meters, Acre Feet, Oil Barrel, Liquid Barrel, Feet, Meters, Lb, Kg, BTU, MBTU, MMBTU, TON Per <i>Second, Minute, Hour, Day</i>
Spare	40604 - 40605	40704 - 40705	
Positive Totalizer	40606 - 40607	40706 - 40707	
Grand Total Totalizer	40608 - 40609	40708 - 40709	
Battery Voltage	40610 - 40611	40710 - 40711	x.xx
Spare	40612 - 40613	40712 - 40713	

TABLE MB4 - MODBUS REGISTER MAP FOR 'BIG-ENDIAN' WORD ORDER MASTER DEVICES

For reference: If the B3000 Totalizer = 12345678 hex
 Register 40606 would contain 1234 hex (Word High)
 Register 40607 would contain 5678 hex (Word Low)

Modbus Coil Description	Modbus Coil	Notes
Reset Running Totalizer	1	Forcing this coil ON will reset the running totalizer. After reset, the coil automatically returns to the OFF state.
Reset Grand Totalizer	2	Forcing this coil ON will reset both the running totalizer and the grand totalizer. After reset, the coil automatically returns to the OFF state.
	3-8	Spares
Alarm Setpoint 1	9	0 = Setpoint OFF, 1 = Setpoint ON
Alarm Setpoint 2	10	0 = Setpoint OFF, 1 = Setpoint ON
	11-16	Spares

TABLE MB5 - MODBUS COIL MAP

OPCODE 01 – READ COIL STATUS

This opcode returns the state of the alarm coils.
The following Coils are defined:

Coil #	Description
9	Alarm Setpoint 1
10	Alarm Setpoint 2
11 and up	Spare

TABLE MB6 - READ COIL STATUS

Command: <addr><01><00><08><00><02><crc-16>
Reply: <addr><01><01><0x><crc-16>

OPCODE 03 – READ HOLDING REGISTERS

This opcode returns the input holding registers, such as flow rate or totalizer.

NOTE: Each value must be requested individually. Return of a block of registers is not implemented at this time.

Example requesting flow rate in floating point format.

Command: <addr><03><00><C9><00><02><crc-16>
Reply: <addr><03><02><data><data><crc-16>

OPCODE 05 – FORCE SINGLE COIL

This opcode sets the state of a single coil (digital output).
The following Coil Registers are defined:

Coil #	Description
1	Reset Totalizer
2	Grand Totals
3 and up	Spares

TABLE MB7 - FORCE SINGLE COIL

The transition of coil from 0 to 1 will initiate function. This bit is auto reset to 0, so there is no need to set it to 0 after a totalizer reset command.

Command: <addr><05><00><00><FF><00><crc-16>
Reply: <addr><05><00><00><FF><00><crc-16>

C SOURCE CODE

A.1.1 CRC-16 Calculations

```
unsigned short crc_table[256] = {
    0x0000, 0xC0C1, 0xC181, 0x0140, 0xC301, 0x03C0, 0x0280, 0xC241,
    0xC601, 0x06C0, 0x0780, 0xC741, 0x0500, 0xC5C1, 0xC481, 0x0440,
    0xCC01, 0x0CC0, 0x0D80, 0xCD41, 0x0F00, 0xCFC1, 0xCE81, 0x0E40,
    0x0A00, 0xCAC1, 0xCB81, 0x0B40, 0xC901, 0x09C0, 0x0880, 0xC841,
    0xD801, 0x18C0, 0x1980, 0xD941, 0x1B00, 0xDBC1, 0xDA81, 0x1A40,
    0x1E00, 0xDEC1, 0xDF81, 0x1F40, 0xDD01, 0x1DC0, 0x1C80, 0xDC41,
    0x1400, 0xD4C1, 0xD581, 0x1540, 0xD701, 0x17C0, 0x1680, 0xD641,
    0xD201, 0x12C0, 0x1380, 0xD341, 0x1100, 0xD1C1, 0xD081, 0x1040,
    0xF001, 0x30C0, 0x3180, 0xF141, 0x3300, 0xF3C1, 0xF281, 0x3240,
    0x3600, 0xF6C1, 0xF781, 0x3740, 0xF501, 0x35C0, 0x3480, 0xF441,
    0x3C00, 0xFCC1, 0xFD81, 0x3D40, 0xFF01, 0x3FC0, 0x3E80, 0xFE41,
    0xFA01, 0x3AC0, 0x3B80, 0xFB41, 0x3900, 0xF9C1, 0xF881, 0x3840,
    0x2800, 0xE8C1, 0xE981, 0x2940, 0xEB01, 0x2BC0, 0x2A80, 0xEA41,
    0xEE01, 0x2EC0, 0x2F80, 0xEF41, 0x2D00, 0xEDC1, 0xEC81, 0x2C40,
    0xE401, 0x24C0, 0x2580, 0xE541, 0x2700, 0xE7C1, 0xE681, 0x2640,
    0x2200, 0xE2C1, 0xE381, 0x2340, 0xE101, 0x21C0, 0x2080, 0xE041,
    0xA001, 0x60C0, 0x6180, 0xA141, 0x6300, 0xA3C1, 0xA281, 0x6240,
    0x6600, 0xA6C1, 0xA781, 0x6740, 0xA501, 0x65C0, 0x6480, 0xA441,
    0x6C00, 0xACC1, 0xAD81, 0x6D40, 0xAF01, 0x6FC0, 0x6E80, 0xAE41,
    0xAA01, 0x6AC0, 0x6B80, 0xAB41, 0x6900, 0xA9C1, 0xA881, 0x6840,
    0x7800, 0xB8C1, 0xB981, 0x7940, 0xBB01, 0x7BC0, 0x7A80, 0xBA41,
    0xBE01, 0x7EC0, 0x7F80, 0xBF41, 0x7D00, 0xBDC1, 0xBC81, 0x7C40,
    0xB401, 0x74C0, 0x7580, 0xB541, 0x7700, 0xB7C1, 0xB681, 0x7640,
    0x7200, 0xB2C1, 0xB381, 0x7340, 0xB101, 0x71C0, 0x7080, 0xB041,
    0x5000, 0x90C1, 0x9181, 0x5140, 0x9301, 0x53C0, 0x5280, 0x9241,
    0x9601, 0x56C0, 0x5780, 0x9741, 0x5500, 0x95C1, 0x9481, 0x5440,
    0x9C01, 0x5CC0, 0x5D80, 0x9D41, 0x5F00, 0x9FC1, 0x9E81, 0x5E40,
    0x5A00, 0x9AC1, 0x9B81, 0x5B40, 0x9901, 0x99C0, 0x9880, 0x9841,
    0x8801, 0x48C0, 0x4980, 0x8941, 0x4B00, 0x8BC1, 0x8A81, 0x4A40,
    0x4E00, 0x8EC1, 0x8F81, 0x4F40, 0x8D01, 0x4DC0, 0x4C80, 0x8C41,
    0x4400, 0x84C1, 0x8581, 0x4540, 0x8701, 0x47C0, 0x4680, 0x8641,
    0x8201, 0x42C0, 0x4380, 0x8341, 0x4100, 0x81C1, 0x8081, 0x4040,
};
```

```
unsigned short calculate_crc(const unsigned char *pv, int size)
{
    unsigned short crc = 0xFFFF;
    for (;size-- ; pv++)
    {
        crc = (crc >> 8) ^ crc_table[(crc ^ *pv) & 0xFF];
    }
    return crc;
}
```

WASTE ELECTRICAL AND ELECTRONIC EQUIPMENT (WEEE) DIRECTIVE



In the European Union, this label indicates that this product should not be disposed of with household waste. It should be deposited at an appropriate facility to enable recovery and recycling.

For information on how to recycle this product responsibly in your country, please visit:

www.racinefed.com/recycle/

CONTACTS AND PROCEDURES

CUSTOMER SERVICE/APPLICATION ENGINEER:

If you have a question regarding order status, placing an order, reviewing applications for future purchases, or wish to purchase a new flow meter, please contact our national sales and marketing headquarters:

BLANCETT

Division of Racine Federated Inc.
8635 Washington Avenue
Racine, WI 53406
PHONE: 800-235-1638 or 262-639-6770
FAX: 262-639-2267

SERVICE/REPAIR DEPARTMENT:

If you already purchased equipment and have an operation problem, require service, or need to schedule field service, please contact our service department:

BLANCETT

Division of Racine Federated Inc.
8635 Washington Avenue
Racine, WI 53406
PHONE: 800-235-1638 or 262-639-6770
FAX: 262-639-2267

RETURN GOODS AUTHORIZATION:

When returning equipment, it is necessary to contact our service department at 800-235-1638 or 262-639-6770 to obtain an RGA number for the authority and proper tracking of your material and its prompt inspection and return. The RGA number should be noted on the outside of the box. All returns of equipment go to the following address:

BLANCETT

Division of Racine Federated Inc.
8635 Washington Avenue
Racine, WI 53406
Attn: RGA #

LIMITED WARRANTY AND DISCLAIMER

Racine Federated Inc. warrants to the end purchaser, for a period of one year from the date of shipment from the factory, that all new flow meters manufactured by it are free from defects in materials and workmanship. This warranty does not cover products that have been damaged due to misapplication, abuse, lack of maintenance, modified or improper installation. Racine Federated Inc.'s obligation under this warranty is limited to the repair or replacement of a defective product, at no charge to the end purchaser, if the product is inspected by Racine Federated Inc. and found to be defective. Repair or replacement is at Racine Federated Inc.'s discretion. An authorization number must be obtained from Racine Federated Inc. before any product may be returned for warranty repair or replacement. The product must be thoroughly cleaned and any process chemicals removed before it will be accepted for return.

The purchaser must determine the applicability of the product for its desired use and assume all risks in connection therewith. Racine Federated Inc. assumes no responsibility or liability for any omissions or errors in connection with the use of its products. Racine Federated Inc. will under no circumstances be liable for any incidental, consequential, contingent or special damages or loss to any person or property arising out of the failure of any product, component or accessory.

All expressed or implied warranties, including the implied warranty of merchantability and the implied warranty of fitness for a particular purpose or application are expressly disclaimed and shall not apply to any products sold or services rendered by Racine Federated Inc.

The above warranty supersedes and is in lieu of all other warranties, either expressed or implied and all other obligations or liabilities. No agent or representative has any authority to alter the terms of this warranty in any way.



NOTES

NOTES

Blancett®

8635 Washington Avenue • Racine, Wisconsin 53406

Toll Free: 800.235.1638

Phone: 262.639.6770 • Fax: 262.417.1155

www.blancett.com • info@blancett.com

BLANCETT is a registered trademark of Racine Federated Inc.
NATIONAL ELECTRICAL CODE is a registered trademark of the NFPA.

© 2012 Racine Federated Inc.
All rights reserved.
Printed in USA

Specifications are subject to change without notice.

Form No. 02-DSY-PM-00003 04/12