

ACCESSORIES FOR AIR VALVES & AIR SYSTEMS

VERSA[®]

BULLETIN
ACC-2000R

AIR VALVES FOR INDUSTRY SINCE 1949

ISO 9001



CERTIFIED

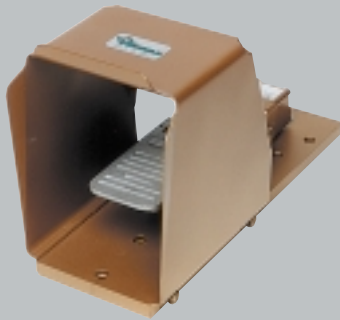

FOOT GUARDS – Page 8



QUICK EXHAUST & ELECTRIC QUICK
EXHAUST VALVES
Pages 6 & 7



SHUTTLE VALVES – Page 4



DUST EXCLUDERS – Page 3



STATUS INDICATORS – Page 5



BLEED CONTROL VALVES – Page 2



www.versa-valves.com

Versa Products Company, Inc., 22 Spring Valley Road, Paramus, New Jersey, USA 07652 • TEL: 201/843-2400 FAX: 201/843-2931
e-mail: sales@versa-valves.com

Versa BV., Halstraat 3, 7321 AG Apeldoorn, The Netherlands • TEL: +31-55-3681900 FAX: +31-55-3681909
e-mail: sales@nl.versa-valves.com

BLEED CONTROL VALVES

(For Pneumatic Control Only)

a range of Bleed Control Valves in different sizes, made of Brass or 316 Stainless Steel

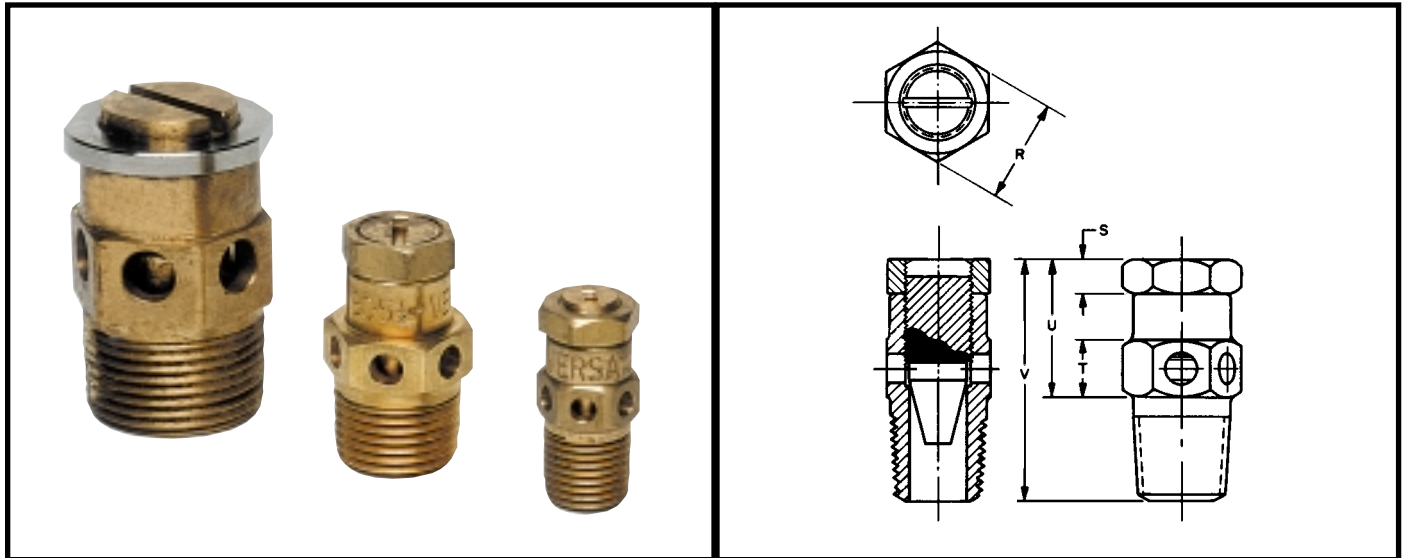

General Description

VERSA Bleed Control Valves provide an economical, effective flow control in pneumatic applications.

They can be screwed into the exhaust port of any VERSA directional control valve to offer "built-in" cylinder speed control.

Functional Description

The VERSA Bleed Control Valve has a precision machined needle. The flow area, through which the air - or any other gas - passes to the atmosphere, can be finely adjusted by screwing the needle in or out. After the Bleed Control Valve has been adjusted to suit, it can be securely locked at its setting with the lock nut provided.

With a VERSA 5/2 or 5/3 four-way valve - having a separate exhaust port for each side of a double acting cylinder - the speed in one direction of stroke may be set at a different speed than the other stroke.

Materials

All parts: - Brass or 316 Stainless Steel†

Pressures

Pressure range: 0 to 200 psi (14 bar) air

Symbol

valve exhaust port

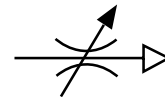

Flow

Exhausting flow can be gradually adjusted from zero (closed) to maximum (full open). Constant flow can be secured at the required setting by tightening the lock nut.

Sizes/Connections/Types/Dimensions/Weights

Connections	Product Number		Dimensions in inch (mm)					Weights	
	brass	st. steel	'R'	'S'	'T'	'U'	'V'	lbs	(kg)
1/8 NPT	BC-2		0.56 (14.3)	0.19 (4.8)	0.31 (7.9)	0.75 (19.1)	1.31 (33.3)	0.07	(0.03)
1/4 NPT	BC-3	BC-3-316	0.56 (14.3)	0.19 (4.8)	0.31 (7.9)	0.75 (19.1)	1.31 (33.3)	0.08	(0.04)
3/8 NPT	BC-4	BC-4-316	0.69 (17.5)	0.25 (6.4)	0.38 (9.5)	0.94 (23.8)	1.56 (39.7)	0.13	(0.06)
1/2 NPT	BC-5	BC-5-316	0.88 (22.2)	0.25 (6.4)	0.38 (9.5)	1.00 (25.4)	1.63 (41.3)	0.15	(0.07)
3/4 NPT	BC-6	BC-6-316	1.31 (33.3)	0.25 (6.4)	0.50 (12.7)	1.50 (38.1)	2.44 (61.9)	0.55	(0.25)
1 NPT	BC-7		1.31 (33.3)	0.25 (6.4)	0.50 (12.7)	1.50 (38.1)	2.44 (61.9)	0.62	(0.28)

†conforms to NACE standard MR-01-75

DUST EXCLUDERS

(For Pneumatic Application Only)

a range of unique Dust Excluders, made from Aluminum or 316 Stainless Steel

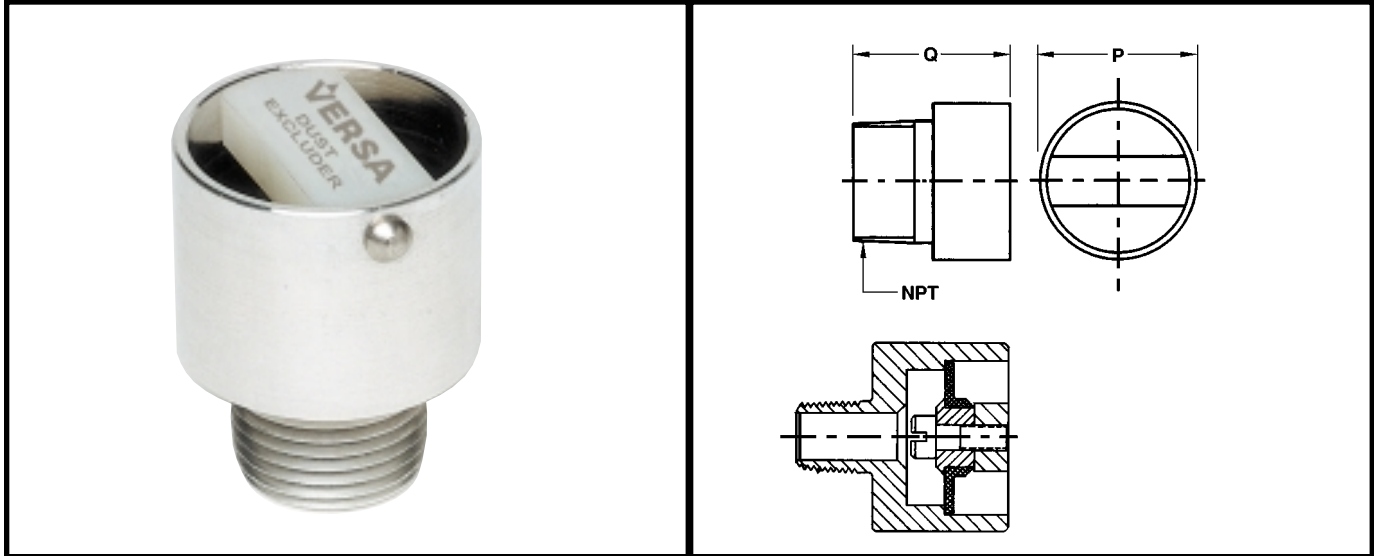

General Description

VERSA Dust Excluders are available in aluminum and in 316 Stainless Steel. They are screwed into the exhaust port of a directional control valve and offer effective protection against all kinds of dirt, dust, moisture and insects entering the valve internals, without obstructing the flow.

Functional Description

The function of the VERSA Dust Excluder is based on a flexible seal resting on a large diameter seat.

This principle offers:

- tightly closed exhaust port
- low 'break away' pressure
- large flow capacity
- self cleaning action.

Materials

Aluminum body with NBR (Nitrile) seal

316 Stainless Steel[†] body with CR (Neoprene) seal

Pressures

Pressure range: 0 to 200 psi (14 bar) air

Symbol

valve exhaust port



Mounting

For best protection Dust Excluders are preferably mounted such that the outlet opens down.

Sizes/Connections/Types/Dimensions/Weights

Connections	Product Number		Dimensions in inch (mm)				Weights in lbs (kg)	
	aluminum	st. steel	'P' alum	'P' st. steel	'Q' alum	'Q' st. steel	aluminum	st. steel
1/8 NPT	DE-2		1.25 (32)		1.56 (40)		0.07 (0.03)	
1/4 NPT	DE-3	DE-3-316	1.25 (32)	1.25 (32)	1.56 (40)	1.18 (30)	0.07 (0.03)	0.15 (0.07)
3/8 NPT	DE-4	DE-4-316	1.25 (32)	1.25 (32)	1.62 (41)	1.25 (32)	0.07 (0.03)	0.17 (0.08)
1/2 NPT	DE-5	DE-5-316	1.25 (32)	1.25 (32)	1.62 (41)	1.25 (32)	0.07 (0.03)	0.19 (0.09)
3/4 NPT	DE-6	DE-6-316	1.37 (35)	1.37 (35)	2.0 (51)	2.0 (51)	0.11 (0.05)	0.30 (0.13)
1 NPT	DE-7		1.37 (35)		2.0 (51)		0.12 (0.06)	

[†]conforms to NACE standard MR-01-75

SHUTTLE VALVES

a range of Shuttle Valves in different sizes, made from Brass or 316 Stainless Steel

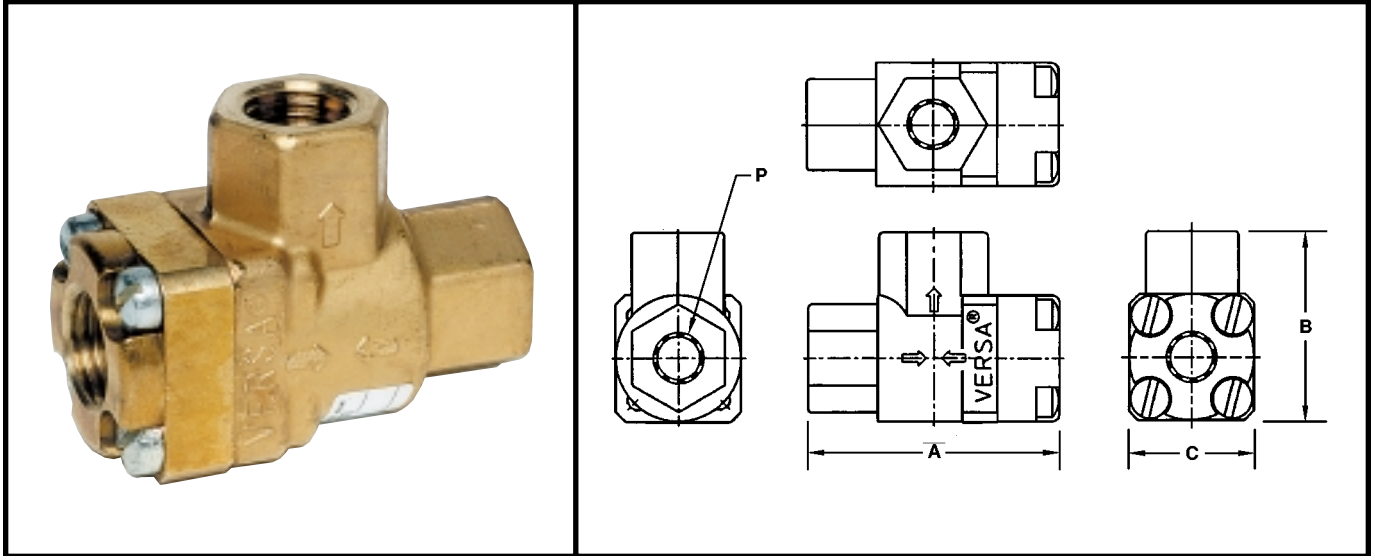

General Description

VERSA Shuttle Valves are constructed of solid Brass or 316 Stainless Steel, with resilient seals providing tight shut off. Shuttle valves are 3/2 valves, primarily used to charge and discharge a pressure line or chamber from two - or more - sources. A typical schematic is shown below:

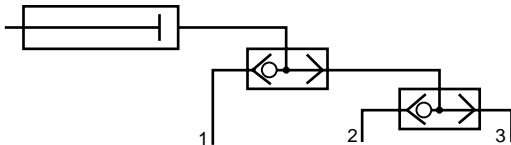

Materials

Type:	Brass	Stainless Steel
Body:	Brass	316 Stainless Steel†
Shuttle:	Nylon(Zytel)	316 Stainless Steel†
Seals:	NBR (Nitrile)	FKM (Fluorocarbon)
Screws:	Plated Steel	316 Stainless Steel†

Functional Description

Shuttle Valves have a free moving shuttle that blocks one of two inlet ports while the other inlet port is connected to the (common) outlet port. When a pressure signal enters the port blocked by the shuttle, it will cause the shuttle to shift over to close the opposite inlet port. The shuttle will stay there while the line or chamber connected to the outlet port is charged and/or discharged and will only shift when pressure is applied to the inlet port it is blocking at that time.

In logic terms a shuttle valve is an 'OR' - function.

Pressures

Pressure range– Pneumatic: 5 to 200 psi (0.35 to 14 bar)
Hydraulic: 5 to 500 psi (0.35 to 35 bar)

Symbol

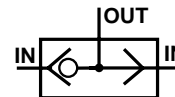

Mounting

Preferably with the centerline of the two inlet ports horizontal. As shown in the drawing above.

Sizes/Connections/Types/Dimensions/Weights

*Porting 'P'	Product Number		Dimensions in inch (mm)			Flow Cv (Kv)		Weights in lbs (kg)	
	brass	st. steel	'A'	'B'	'C'	brass	st. steel	brass	st. steel
1/8 NPT	SV-2		2.0 (51)	1.5 (38)	1.0 (25)	0.8 (12)		0.57 (0.26)	
1/4 NPT	SV-3	SV-3-316	2.0 (51)	1.5 (38)	1.0 (25)	0.8 (12)	0.5 (7)	0.57 (0.26)	0.33 (0.15)
3/8 NPT	SV-4		2.5 (64)	1.9 (48)	1.3 (32)	1.6 (23)		1.10 (0.50)	
1/2 NPT	SV-5		2.5 (64)	1.9 (48)	1.3 (32)	2.1 (30)		1.10 (0.50)	
3/4 NPT	SV-6		3.5 (89)	2.8 (70)	1.5 (38)	6.5 (84)		2.16 (0.98)	

* For Subplate Mounting Shuttle Valves Consult Factory

† conforms to NACE standard MR-01-75

STATUS INDICATOR

a Pressure Indicator, made from 316 Stainless Steel

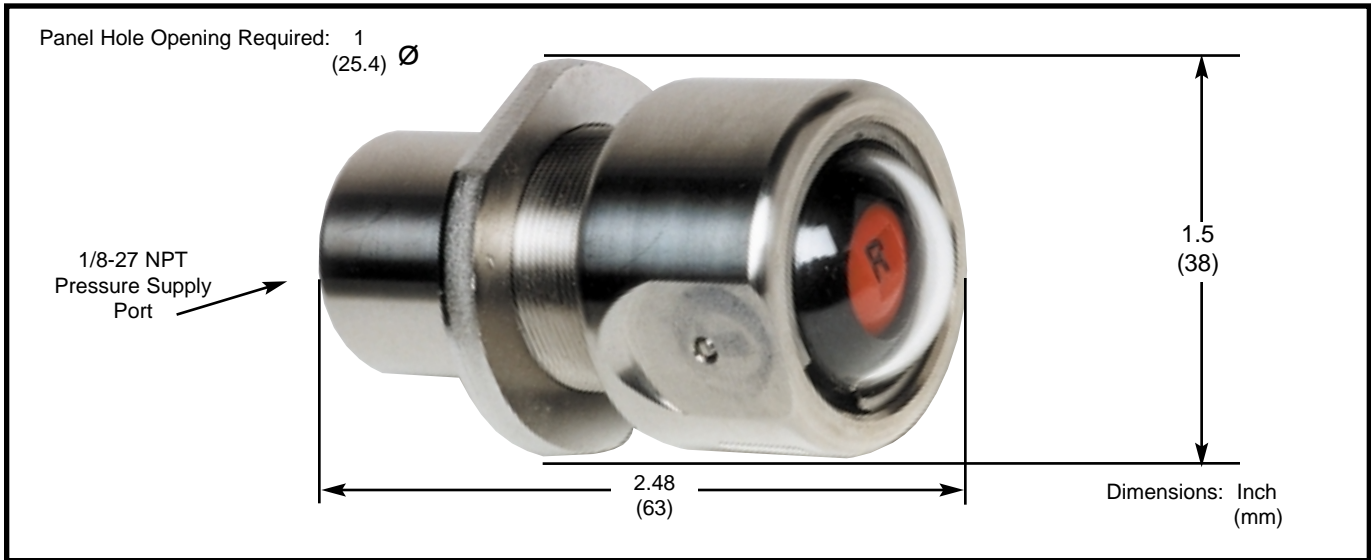

General Description

Some applications require visual indication when a system is pressurized or when a system has lost pressure. The Versa Status Indicator provides such a display within a stainless steel shell that can be mounted as an integral part of a panel. Viewing the panel provides the operator with an instantaneous evaluation of the pressure condition in the system or systems being monitored.

Functional Description

Versa's Status Indicator provides visual indication of pressure in a system. The standard product displays a green field when a minimum of 8 psi (0.55 bar) to a maximum of 200 psi (14 bar) is present. Complete loss of pressure causes the indicator to display a red field, marked with the recognition character "R". Other field colors are available. See TYPES below.

Types/Weights

Product Number	Operating Pressure Range		Weights
	Depressurized 0 psi (0 bar)	Pressurized 8 psi (0.55 bar) to 200 psi (14 bar)	
SI-2-316	Red (R)	Green	} 0.50 lbs. (0.23 kg)
SI-2-316-403GR	Green (G)	Red	
SI-2-316-403YG	Yellow (Y)	Green	
SI-2-316-403GY	Green (G)	Yellow	

*For hydraulic service consult factory.

†Conforms to NACE standard MR-01-75

Materials:

Body and internal wetted metal parts– 316 Stainless Steel†
 Working seals– FKM (Fluorocarbon)
 Lens–polycarbonate (sealed to prevent moisture intrusion), resistant to ultraviolet rays

Porting and panel hole:

1/8 NPT pressure supply port

Pressures

Operating pressure range: 0 to 200 psi (14 bar) air*

Mounting

Panel hole opening 1" (25.4mm) Ø
 Can be mounted in any orientation with maximum panel thickness 0.50" (12.7 mm) with one panel nut; maximum panel thickness 0.21" (5.3 mm) with two panel nuts (suffix -43E)

QUICK EXHAUST VALVES

(For Pneumatic Application Only)

Quick Exhaust Valves in two different sizes and materials

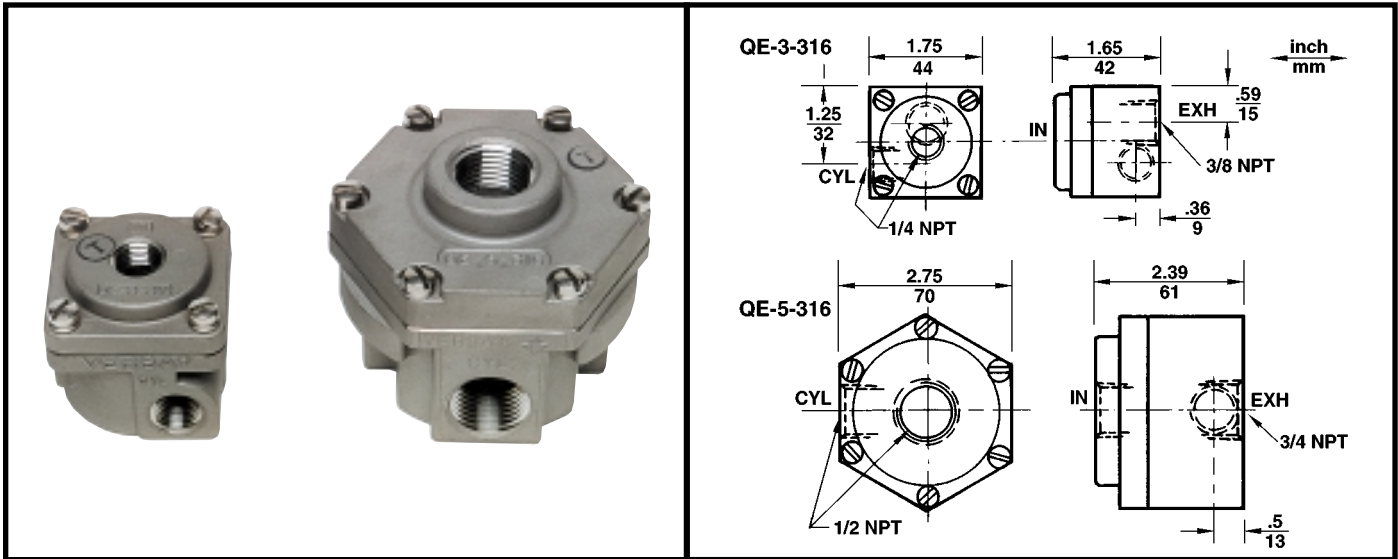

General Description

A Quick Exhaust Valve is a 3/2 valve with extra large exhaust orifice, designed to be fitted directly at a cylinder port connection. The main purpose of a Quick Exhaust Valve is to get extra fast movement of the cylinder rod or valve actuator.

Functional Description

A Quick Exhaust Valve is a three-port valve with one inlet port, one cylinder port and a larger exhaust port. When the inlet port is pressurized, the exhaust port is closed by the 'flapper' - which is a soft-material seal - and the inlet port is connected with the cylinder port. When pressure falls at the inlet of the Quick Exhaust Valve, the cylinder port is automatically opened to the exhaust and the cylinder is rapidly depressurized.

Materials

Body: 316 Stainless Steel† or Electroless Nickel Plated Brass
 Seals: FKM (Fluorocarbon) O ring seals;
 CR (Neoprene) coated Nylon flapper.
 Screws: 316 Stainless Steel†

Pressure range:

5 to 150 psi (0.35 to 10 bar) air

Temperature range:

-20°F to +200°F
 (-29°C to +93°C)

Symbol

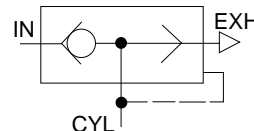

Sizes/Connections/Types/Weights/Flow

Port Sizes		Product Number	Weights	Product Number		Flow	
IN & CYL	EXH			Stainless Steel	Electroless Nickel Plated Brass	IN to CYL	CYL to EXH
1/4 NPT	3/8 NPT	QE-3-316	0.90 lbs (0.4 kg)	QE-3	1.18 lbs (2.6 kg)	C _V 3.0 (K _V 43.5)	C _V 3.3 (K _V 48)
1/2 NPT	3/4 NPT	QE-5-316	2.25 lbs (1.0 kg)			C _V 3.8 (K _V 55)	C _V 8.8 (K _V 128)

†conforms to NACE standard MR-01-75

ELECTRIC QUICK EXHAUST VALVES

(For Pneumatic Application Only)

a perfect solution to remote operation of Quick Exhaust Valves

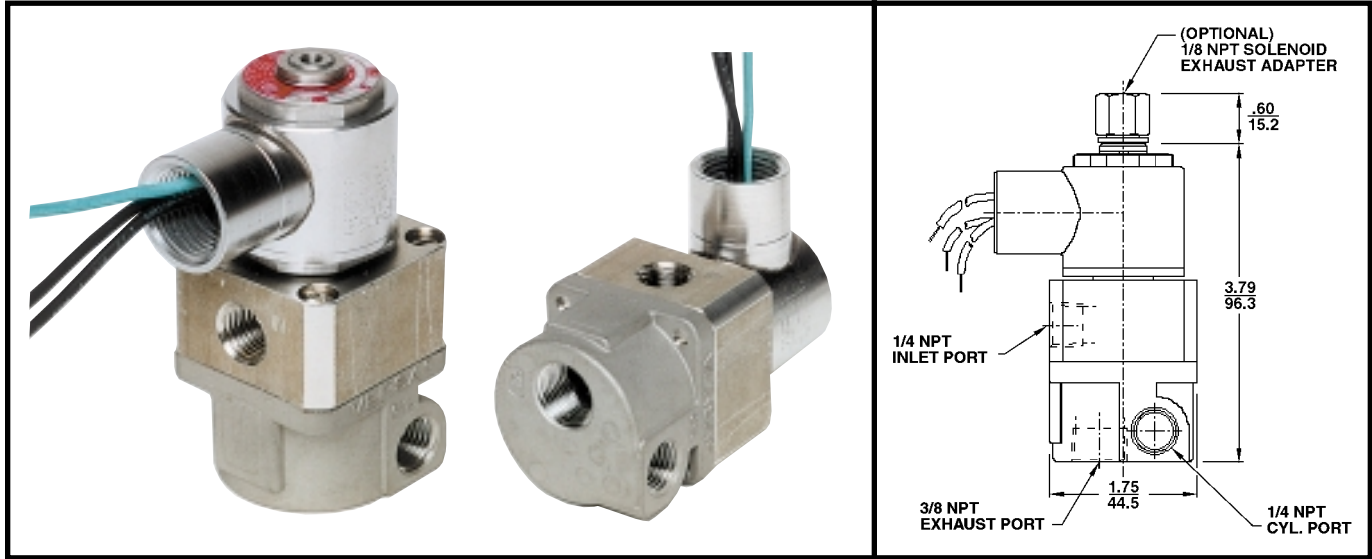

General Description

The Electric Quick Exhaust Valve is a three-way NC, 3/2 valve with extra large exhaust orifice in order to provide extra fast movement of the cylinder rod, or to exhaust systems rapidly. It may be close nipped to the actuator or system that it exhausts, or it may be remotely located.

Functional Description

When the solenoid is energized, the cylinder port is connected to the inlet port and the exhaust port is closed by the "flapper" - which is a soft-material seal. When the solenoid is de-energized, the inlet of the Quick Exhaust Valve is closed and the cylinder port is connected with the exhaust port, providing rapid evacuation. This valve may be actuated electrically at any time.

Materials

Body: 316 stainless steel†
 Solenoid Operator: 304 & 430F stainless steel (wetted parts)
 Seals: FKM (Fluorocarbon) O ring seals;
 CR (neoprene) coated nylon flapper.
 Screws: stainless steel†

Symbol

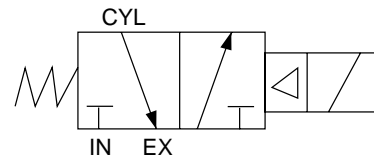

Pressure	Types		Flow		Weights
	Ordinary location NEMA 1,2,3	Hazardous Location Service* (UL listed or CSA approved for Class I-Groups C & D, Class II-Groups E, F & G) NEMA 7 & 9	In to Cyl	Cyl to Ex	
5-150 psi (0.3-10 bar) 5-100 psi (0.3-6.9 bar) 5-60 psi (0.3-4 bar) 5-30 psi (0.3-2 bar)	E5QE-30303-316 E5QE-30404-316 E5QE-30604-316 E5QE-30804-316	E5QE-30303-316-XX E5QE-30404-316-XX E5QE-30604-316-XX E5QE-30804-316-XX	$C_v=.055 (K_v=.80)$ $C_v=.075(K_v=1.1)$ $C_v=.156(K_v=2.26)$ $C_v=.230(K_v=3.34)$	$C_v=3.3(K_v=48)$	1.85 lbs. (.84Kg)
Available Voltages Class A Epoxy molded coil	AC 50 & 60 Hz 60 to 575 volts Nominal coil power: 6 Watts	DC 3 to 300 volts Nominal coil power: 7 Watts	* Consult factory for other hazardous service, low-watt service, and intrinsically safe solenoids.		
Suffix Options Threaded Solenoid Exhaust Adapter: Potted Coil: Stainless steel 182FM) coil cover:	-H2 -PC	-H2 -PC -ST			

† conforms to NACE standard MR-01-75

FOOT GUARD

an ideal Foot Guard for use with any Versa pedal* operated valve

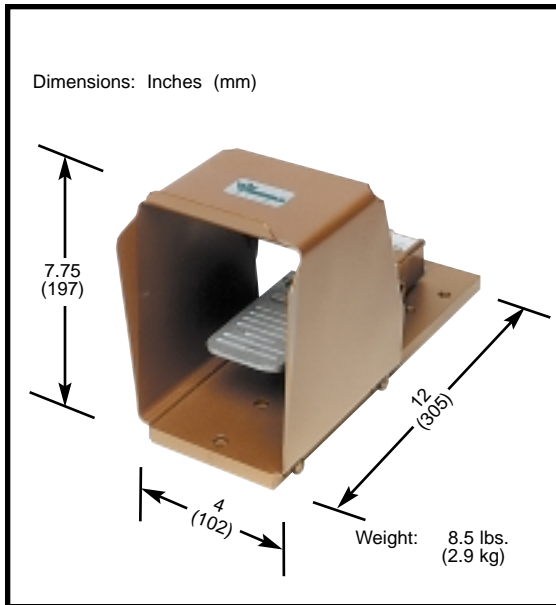

*Any Versa valve with the prefix product letter "F," i.e. VSF-3301.
Not suitable for treadle operation.

General Description

Heavy all-steel construction protects the valve mechanism from abuse. Acts as a sturdy base for valves that cannot be secured to floor or equipment, or may be bolted down for permanent installation. One size Foot Guard fits all sizes and types of pedal actuated Versa Valves. If the wrong side of the bottom mounting plate is up for a particular valve, simply remove the four screws holding cover to the plate, turn the plate over; reassemble.

Product Number

FG - 1R (when pedal is on right end of valve looking at inlet port.)

FG - 1L (when pedal is on left end of valve looking at inlet port.)

BLEED VALVES

(For Pneumatic Control Only)

a low cost, simple way to manually or mechanically control bleed functions

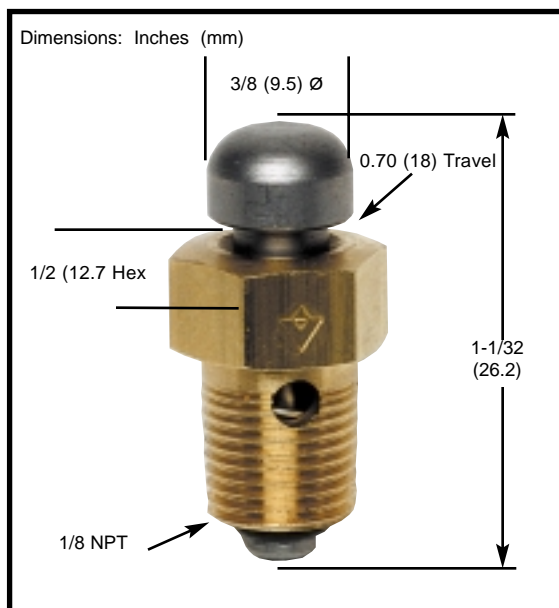

Functional Description

These versatile valves can be used to operate a bleed pilot control valve. Bleed valves are used to vent pressure from one end of the control valve to allow pressure from the opposite end to shift the spool, changing the flow pattern.

Installation can be made directly on the pilot cap or at a remote location by simply running a single line from the bleed button valve to the pilot cap.

Materials

- Body: Brass
- Plunger & Spring: 440 & 302 Stainless Steel
- Seals: NBR (Nitrile)

Pressures

Pressure range: 0 to 200 psi (0 to 14 bar) air

Symbol

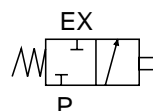

Product Number

BV-2

Versa exercises diligence to assure that information contained in this catalog is correct, but does not accept responsibility for any errors or omissions. Versa also reserves the right to change or delete data or products at any time without prior notification. To be sure the data you require is correct consult factory.