



MLS Series Liquid Level Switches

Installation and Operations Manual

In order to consistently bring you the highest quality full featured products, we reserve the right to change our specifications and designs at any time. The latest version of this manual can be found at www.fwmurphy.com.

Warranty - A limited warranty on materials and workmanship is given with this FW Murphy product. A copy of the warranty may be viewed or printed by going to <http://www.fwmurphy.com/warranty>



CAUTION: MLS Series parts are not interchangeable with other Murphy liquid level products. Damage caused by using incorrect parts is not covered by our Limited Warranty.



Please read the following information before installing. A visual inspection for damage during shipping is recommended before mounting.

BEFORE BEGINNING INSTALLATION OF THIS MURPHY PRODUCT:

Disconnect all electrical power to the machine.

Make sure the machine cannot operate during installation.

Follow all safety warnings of the machine manufacturer.

Read and follow all installation instructions.

OBSERVE all pressure and electrical ratings and requirements for the devices and the operating environment.

BE SURE all pressure HAS BEEN REMOVED from the vessel before opening any pressure connections.

Please contact FW MURPHY immediately if you have any questions.

Table of Contents

Product Information	1
Features	1
MLS-020, MLS-015	1
Pressure Vessel Installation: MLS-020 and MLS-015	2
Direct Installation into the Wall of the Pressure Vessel	2
Installation with a Weld Collar	3
Installation Using Murphy External Float Chamber	3
Electrical Wiring	4
Replacement Parts	4
15000531: MLS Float	4
Accessories	4
15050375: Weld Collar.....	4
15051098: External Float Chamber	5
15700799: Series 100 External Float Chamber	5
Specifications	6
MLS Series.....	6
Approximate Shipping Weights and Dimensions.....	6

(THIS PAGE INTENTIONALLY LEFT BLANK)

Product Information

Features

- Clean Magnet Design virtually eliminates iron filing accumulation onto the magnet
- Seal-Free Construction
- Designed for harsh gas compressor scrubber applications
- CF8 (304) cast stainless steel body and 304 stainless steel float
- MLS Series rated for 2000 psi (13.8 MPa) [138 bar] working pressure
- Electric model only available
- Improved design provides better dependability with reduced number of moving parts
- All models screw directly into the scrubber or can be mounted via external float chamber
- CSA C/US Class 1, Div. 1, Grp. B, C & D locations
- Canadian Registration Number: 0F01476.2

MLS-020, MLS-015

MLS Series Liquid Level Switches with 2" NPT and 1-1/2" NPT mounting are float activated to operate an electrical SPDT reed switch for alarm or shutdown of an engine or electric motor. The MLS Series connects directly into the scrubber wall and can be used with a Murphy weld collar (P/N 15050375) or Murphy external float chamber (P/N 15700799).

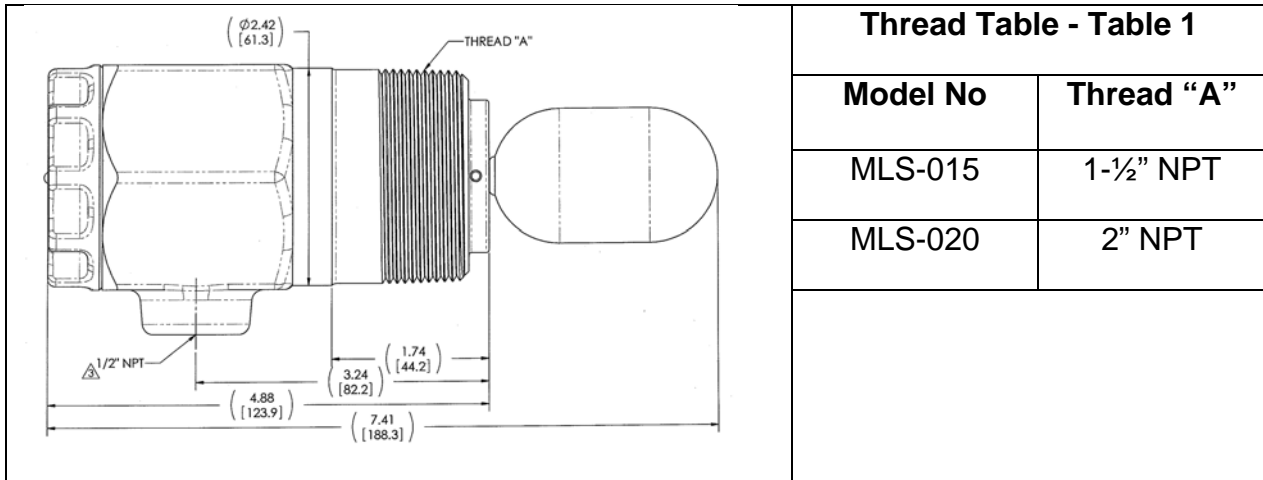

NOTE: Refer to Table 2 for clearances.

Pressure Vessel Installation: MLS-020 and MLS-015

Direct Installation into the Wall of the Pressure Vessel

CAUTION: Determine that the float travel is not obstructed by the coupling in the vessel wall, internal baffles, etc.
 Refer to tables 1 and 2 for application data. INSTALLATION BY QUALIFIED PERSONNEL ONLY.

1. Make certain the float is tightly screwed onto the counter-balance.
2. Before installing the level switch, use of a pipe thread sealant is recommended. Screw the unit directly into the threaded connection in the wall of the pressure vessel.
3. Verify that the electrical connection is positioned at the bottom.

NOTE: The word TOP is cast into the top of the body. M

4. Make the electrical wiring connections according to appropriate wiring diagrams for the alarm or shutdown system to be used. The electrical connection is 1/2"-14 NPT.
5. Ensure all electrical connections are insulated and the cover is fully installed before reconnecting electrical power.
6. Verify all pressure connections are tight before pressurizing the system.

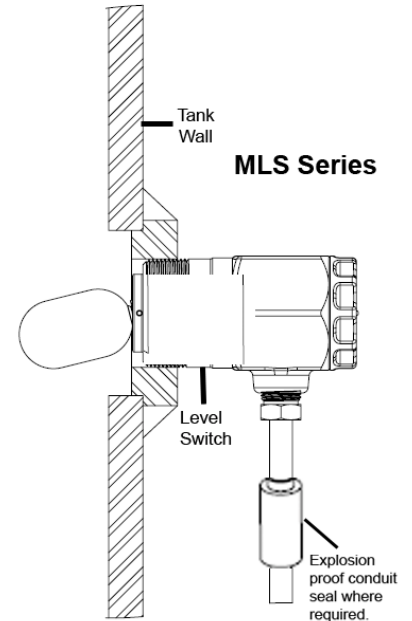

Float Clearance Reference Tables

Nom. Size (inches)	O.D. (inches)	Schedule Number	Wall Thickness (inches)	Inside Diameter (inches)
2.5	2.875	40STD	0.203	2.469
3	3.5	40STD	0.216	3.068
3	3.5	80XS	0.3	2.9
4	4.5	40STD	0.237	4.026
4	4.5	80XS	0.337	3.826

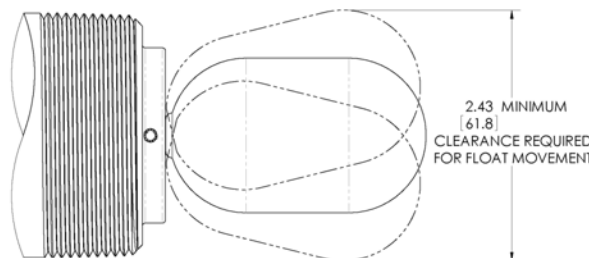

Installation with a Weld Collar

1. The weld collar, P/N 15050375, must be welded into the wall of the pressure vessel according to code standards and good welding practices.
2. Follow above instructions for installation directly into the wall of the pressure vessel.

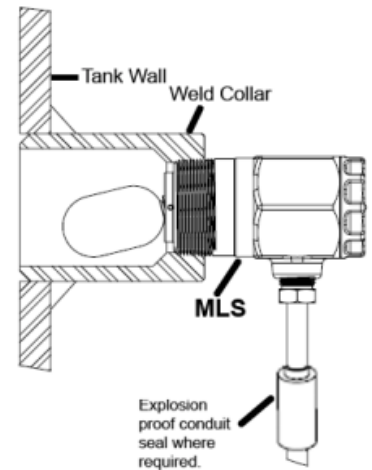

Installation Using Murphy External Float Chamber

1. Install the Murphy float chamber 15051098 or 15700799 on the outside wall of the pressure vessel using 1" NPT piping. Position the 2" NPT threaded connection at the height where you want the level switch to operate. The 2" NPT threaded connection must be positioned away from the tank wall.

NOTE: If using Float Chamber 15051098, best practices recommend a surface mount installation.

2. A tee and bleed valve are typically installed at the bottom of the lower 1 inch pipe riser to allow draining of the float chamber for servicing or replacement.

NOTE: A typical installation with blocking and bleed valves is shown at right.

3. Install the MLS-020 in the 2" NPT connection of the float chamber. BE SURE float travel is not restricted and that the float is tight onto the counter-balance.
4. To complete the installation and wiring, follow the instructions for mounting directly into wall of the vessel and for wiring.

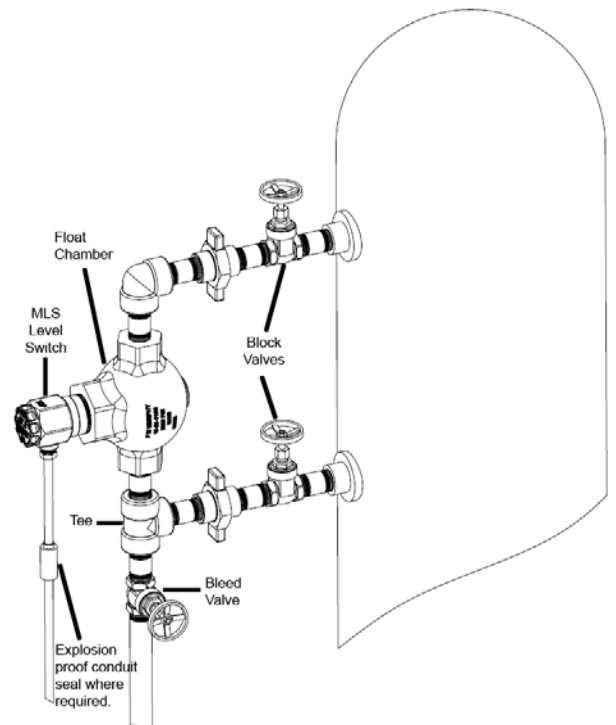

Electrical Wiring

STD WIRING DIAGRAM

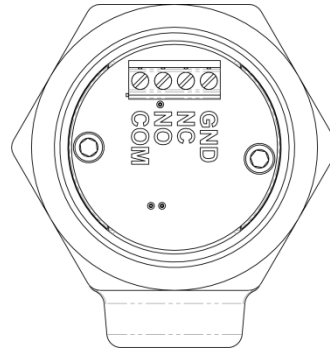
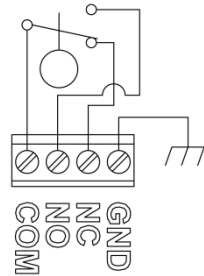

Switch Rating: 30VDC/VAC @ 75 mA

Replacement Parts

Order by part number designation.

15000531: MLS Float

Stainless Steel Float, MLS Series (not interchangeable with any other Murphy Level Switch Float)

Accessories

15050375: Weld Collar

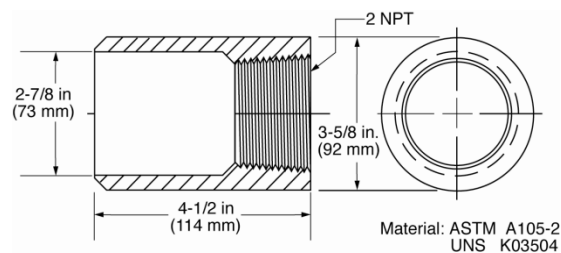

Operating Pressure: 2000 psi (13.8 MPa) [138 bar].

Operating Temperature: 400°F (204°C).

15051098: External Float Chamber

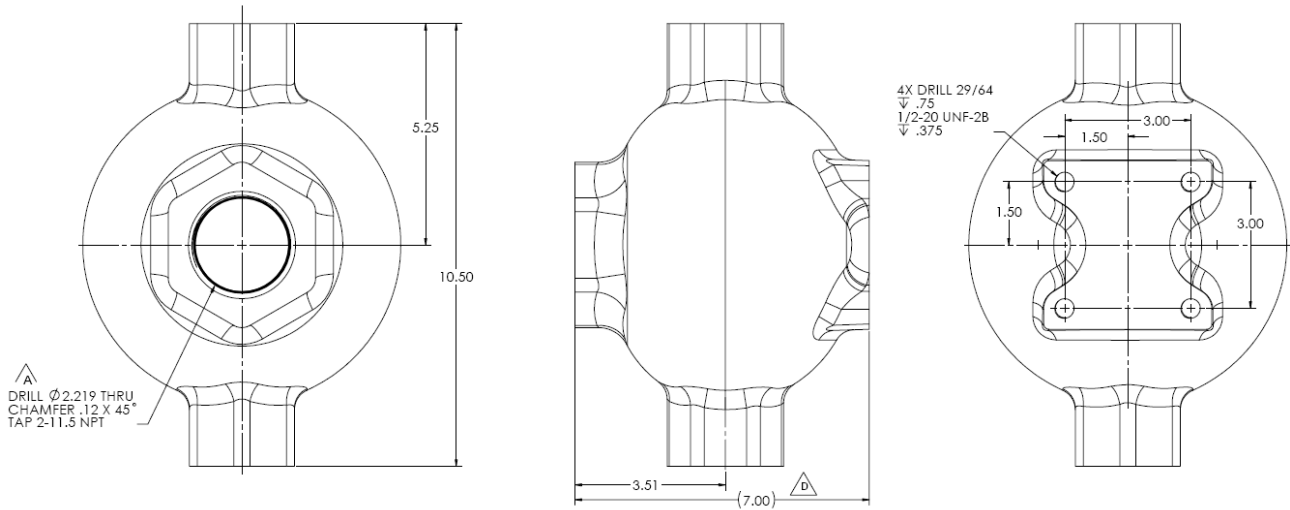

Operating pressure: 2000 psi (13.8 MPa) [138 bar]

Operating temperature: 400°F (204°C).

15700799: Series 100 External Float Chamber

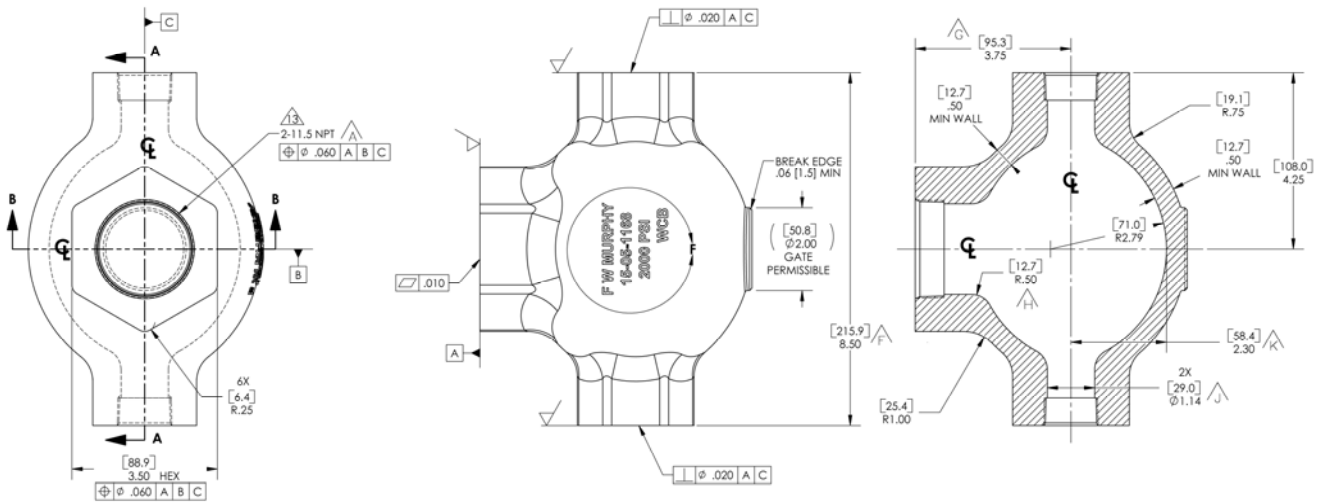

Operating pressure: 2000 psi (13.8 MPa) [138 bar]

Operating temperature: 400°F (204°C).

Specifications

MLS Series

Process connection: 2" NPT (MLS-020)
1-1/2" NPT (MLS-015)

Fluid Density (SG): 0.50

Pressure Rating: 2000 psig (13.8 MPa)[138 bar]

Materials:

Body: ASTM A351 CF8 (304 SS)

Cover: ASTM A351 CF8 (304 SS)

Other Wetted Parts: 304 or 316 SS

Meets NACE MR0175 for direct exposure to H₂S

Process Temperature: -20 to 300°F (-29 to 149°C)

Electrical: 30VAC/VDC 75mA Form C SPDT

Approximate Shipping Weights and Dimensions

All models: 5.5lbs (2.49 kg);

Dimensions: 14 x 5 x 3.5 in. (356 x 127 x 89 mm)

THIS PAGE INTENTIONALLY LEFT BLANK.

In order to consistently bring you the highest quality, full featured products, we reserve the right to change our specifications and designs at any time. MURPHY products and the Murphy logo are registered and/or common law trademarks of Murphy Industries, LLC. This document, including textual matter and illustrations, is copyright protected by Murphy Industries, LLC, with all rights reserved. (c) 2011 Murphy Industries, LLC.

FW MURPHY

P.O. Box 470248
Tulsa, Oklahoma 74147 USA
Phone: +1 918 317 4100 Fax: +1 918 317 4266
E-mail: sales@fwmurphy.com

INDUSTRIAL PANEL DIVISION

Fax: +1 918 317 4124
E-mail: ipdsales@fwmurphy.com

MURPHY POWER IGNITION

Web site: www.murphy-pi.com

CONTROL SYSTEMS & SERVICES DIVISION

P.O. Box 1819
Rosenberg, Texas 77471 USA
Phone: +1 281 633 4500 Fax: +1 281 633 4588
E-mail: css-solutions@fwmurphy.com

FRANK W. MURPHY LTD.

Church Road, Laverstock
Salisbury, SP1 1QZ, UK
Phone: +44 1722 410055 Fax: +44 1722 410088
E-mail: sales@fwmurphy.co.uk
Web site: www.fwmurphy.co.uk

COMPUTRONIC CONTROLS

41 - 46 Railway Terrace
Nechells, Birmingham, B7 5NG, UK
E-mail: sales@computroniccontrols.com
Web site: www.computroniccontrols.com

www.fwmurphy.com

FW MURPHY INSTRUMENTS (HANGZHOU) CO., LTD.

77 23rd Street
Hangzhou Economic & Technological Development Area
Hangzhou, Zhejiang, 310018, China
Phone: +86 571 8788 6060 Fax: +86 571 8684 8878
E-mail: epsales@fwmurphy.com



USA-ISO 9001:2008 FM 28221
UK-ISO 9001:2008 FM 29422
CHINA-ISO 9001:2008 FM 523851
Registered Facilities



Printed in U. S. A.

02/11/2011