

UDC3300 Basic Model: DC330B User Manual

51-52-25-78

5/00

Notices and Trademarks

Copyright 2000 by Honeywell
Release 0 May, 2000

Warranty/Remedy

Honeywell warrants goods of its manufacture as being free of defective materials and faulty workmanship. Contact your local sales office for warranty information. If warranted goods are returned to Honeywell during the period of coverage, Honeywell will repair or replace without charge those items it finds defective. The foregoing is Buyer's sole remedy and is **in lieu of all other warranties, expressed or implied, including those of merchantability and fitness for a particular purpose.** Specifications may change without notice. The information we supply is believed to be accurate and reliable as of this printing. However, we assume no responsibility for its use.

While we provide application assistance personally, through our literature and the Honeywell web site, it is up to the customer to determine the suitability of the product in the application.

Sensing and Control

Honeywell
11 West Spring Street
Freeport, IL 61032

UDC2300 is a U.S. registered trademark of Honeywell

Other brand or product names are trademarks of their respective owners.

About This Document

Abstract

This manual contains all the information that is needed to install, configure and operate the UDC3300 Universal Digital Controller. Further details on operation, troubleshooting or calibration can be found in the full UDC3300 product manual (request document number 51-52-25-55).

Contacts

World Wide Web

The following lists Honeywell's World Wide Web sites that will be of interest to our customers.

Honeywell Organization	WWW Address (URL)
Corporate	http://www.honeywell.com
Sensing and Control	http://www.honeywell.com/sensing
International	http://www.honeywell.com/Business/global.asp







Telephone

Contact us by telephone at the numbers listed below.

	Organization	Phone Number
United States and Canada	Honeywell	1-800-423-9883
		(610) 641-3610 <i>Tech. Support</i>
		1-888-423-9883 <i>Q&A Faxback (TACFACS)</i>
		1-800-525-7439 <i>Service</i>
Asia Pacific	Honeywell Asia Pacific Hong Kong	(852) 2829-8298
Europe	Honeywell PACE, Brussels, Belgium	[32-2] 728-2111
Latin America	Honeywell, Sunrise, Florida U.S.A.	(954) 845-2600

Symbol Definitions

The following table lists those symbols used in this document to denote certain conditions.

Symbol	Definition
	This CAUTION symbol on the equipment refers the user to the Product Manual for additional information. This symbol appears next to required information in the manual.
	WARNING PERSONAL INJURY: Risk of electrical shock. This symbol warns the user of a potential shock hazard where HAZARDOUS LIVE voltages greater than 30 Vrms, 42.4 Vpeak, or 60 Vdc may be accessible. Failure to comply with these instructions could result in death or serious injury.
	ATTENTION, Electrostatic Discharge (ESD) hazards. Observe precautions for handling electrostatic sensitive devices
	Protective Earth (PE) terminal. Provided for connection of the protective earth (green or green/yellow) supply system conductor.
	Functional earth terminal. Used for non-safety purposes such as noise immunity improvement. NOTE: This connection shall be bonded to protective earth at the source of supply in accordance with national local electrical code requirements.
	Earth Ground. Functional earth connection. NOTE: This connection shall be bonded to Protective earth at the source of supply in accordance with national and local electrical code requirements.
	Chassis Ground. Identifies a connection to the chassis or frame of the equipment shall be bonded to Protective Earth at the source of supply in accordance with national and local electrical code requirements.

Contents

1. INTRODUCTION.....	1
1.1 Overview	1
1.2 CE Conformity (Europe).....	1
1.3 Function Keys	2
2. INSTALLATION	3
2.1 Mounting	3
2.2 Wiring	4
3. CONFIGURATION	19
3.1 Overview	19
3.2 Configuration Procedure	21
3.3 Loop 1 Tuning Parameters Set Up Group	22
3.4 SP Ramp, SP Rate, or SP Programming Set Up Group.....	24
3.5 Accutune Set Up Group	26
3.6 Algorithm Data Set Up Group.....	26
3.7 Output Algorithm Parameters Set Up Group	28
3.8 Input 1 Parameters Set Up Group.....	29
3.9 Input 2 Parameters Set Up Group.....	30
3.10 Loop 1 Control Parameters Set Up Group	31
3.11 Options Set Up Group.....	33
3.12 Communications Set Up Group.....	34
3.13 Alarms Set Up Group	36
3.14 Display Parameters Set Up Group	38
3.15 Calibration Group	38
3.16 Status Group.....	38
4. OPERATION	39
4.1 How to Power Up the Controller	39
4.2 Monitoring Your Controller	39
4.3 Start-up Procedure.....	42
4.4 Operating Modes.....	43
4.5 Setpoints	43
4.6 Using Two Sets of Tuning Constants	44
4.7 Alarm Setpoints.....	46

4.8	Three Position Step Control Algorithm	46
4.9	Input Math Algorithms	47
4.10	Digital Input Option (Remote Switching).....	48
4.11	Fuzzy Overshoot Suppression	50
4.12	Accutune	50
4.13	Entering a Security Code	52
5.	SETPOINT RATE/RAMP/SOAK PROGRAM OPERATION	53
5.1	Setpoint Ramp Rate.....	53
5.2	Single Setpoint Ramp	53
5.3	Setpoint Ramp/Soak Programming Option	55
6.	APPENDIX A – ENVIRONMENTAL AND OPERATING CONDITIONS	63
7.	APPENDIX B – MODEL SELECTION GUIDE.....	65
8.	APPENDIX C – CONFIGURATION RECORD SHEET	67
9.	APPENDIX D – POSITION PROPORTIONAL CALIBRATION	69
9.1	Position Proportional Control Output Calibration	69
10.	APPENDIX E – INPUT RANGES.....	73

Tables

Table 1-1	Function of Keys	2
Table 2-1	Permissible Wiring Bundling	5
Table 2-2	Input 2 Jumper Selections	9
Table 2-3	Control Relay Contact Information	17
Table 2-4	Alarm Relay Contact Information	17
Table 3-1	Configuration Procedure	21
Table 3-2	Tuning Group Function Prompts	22
Table 3-3	SP Ramp Function Prompts	24
Table 3-4	Accutune Group Function Prompts	26
Table 3-5	Algorithm Group Function Prompts	26
Table 3-6	Output Algorithm Group Function Prompts	28
Table 3-7	Input 1 Group Function Prompts	29
Table 3-8	Input 2 Group Function Prompts	30
Table 3-9	Control Group Function Prompts	31
Table 3-10	Options Group Function Prompt	33
Table 3-11	Communications Group Function Prompts	34
Table 3-12	Alarms Group Function Prompts	36
Table 3-13	Display Group Function Prompts	38
Table 4-1	Lower Display Key Parameter Prompts	40
Table 4-2	Error Messages	41
Table 4-3	Procedure for Starting Up the Controller	42
Table 4-4	Setpoint Selection Indication	44
Table 4-5	Procedure for Selecting Two Sets of Tuning Constants	44
Table 4-6	Procedure for Setting Switchover Values	44
Table 4-7	Procedure for Setting Tuning Constant Values	45
Table 4-8	Procedure for Switching PID SETS from the Keyboard	45
Table 4-9	Procedure for Displaying or Changing the Alarm Setpoints	46
Table 4-10	Procedure for Displaying the 3PSTEP Motor Position	46
Table 4-11	Digital Input Option Action on Contact Closure	48
Table 4-12	Digital Input Combinations "DIG IN1" or "DIG IN2"	49
Table 4-13	Procedure for Starting TUNE (Demand) Tuning	51
Table 4-14	Procedure for Using TUNE at Start-up for Duplex	52
Table 4-15	Procedure to Enter a Security Code	52
Table 5-1	Procedure for Running a Setpoint Ramp	54
Table 5-2	Program Contents	56
Table 5-3	Run/Monitor Functions	60
Table 9-1	Calibration Procedure	70

Figures

Figure 1-1	Operator Interface Displays and Indicators	1
Figure 2-1	Dimensions	3
Figure 2-2	Mounting Method	4
Figure 2-3	Composite Wiring Diagram	6
Figure 2-4	Line Voltage Wiring	7
Figure 2-5	Input #1/#2 Connections	8
Figure 2-6	Electromechanical Relay Output – Model DC330X-EE-XXX	9
Figure 2-7	Solid State (SS) Relay Output — Model DC33X-AA-XX	10
Figure 2-8	10-amp SS External Relay Output — Model DC330X-SS-XX	10
Figure 2-9	Open Collector Output — Model DC330X-TT-XXX	11
Figure 2-10	Current Output Current/Time Duplex, Time/Current Duplex, Position Proportional or Three Position Step Control	12
Figure 2-11	Auxiliary Output and Three-Relay Output	12
Figure 2-12	Position Proportional Output or Three Position Step—Models DC330X-EE-XXX-X2, DC330X-AA-XXX-X2	13
Figure 2-13	Auxiliary Output Connections— Models DC330X-XX-2XX, DC330X-XX-5XX	14
Figure 2-14	Digital Inputs Connections—Model DC330X-XX-XX3	14
Figure 2-15	RS422/485/ASCII or Modbus Communications Option Connections	15
Figure 2-16	Transmitter Power for 4-20 mA 2-wire Transmitter Using Open Collector Alarm 2 Output—Model DC330X-XT-XXX	16
Figure 2-17	Transmitter Power for 4-20 mA 2-wire Transmitter Using Auxiliary Output—Model DC330X-XX-2XX or DC330X-XX-5XX	16
Figure 3-1	Prompt Hierarchy	19
Figure 5-1	Ramp/Soak Profile Example	58
Figure 5-2	Program Record Sheet	59

1. Introduction

1.1 Overview

The UDC 3300 is a microprocessor-based, stand-alone controller. It combines the highest degree of functionality and operating simplicity offered in a 1/4 DIN size controller.

With a typical accuracy of $\pm 0.20\%$ of span, the UDC 3300 is an ideal controller for regulating temperature and other process variables in numerous heating and cooling applications, in metal working, food, and pharmaceuticals, and testing and environmental work.

1.2 CE Conformity (Europe)

This product is in conformity with the protection requirements of the following European Council Directives: **73/23/EEC**, the Low Voltage Directive, and **89/336/EEC**, the EMC Directive. Conformity of this product with any other "CE Mark" Directive(s) shall not be assumed.

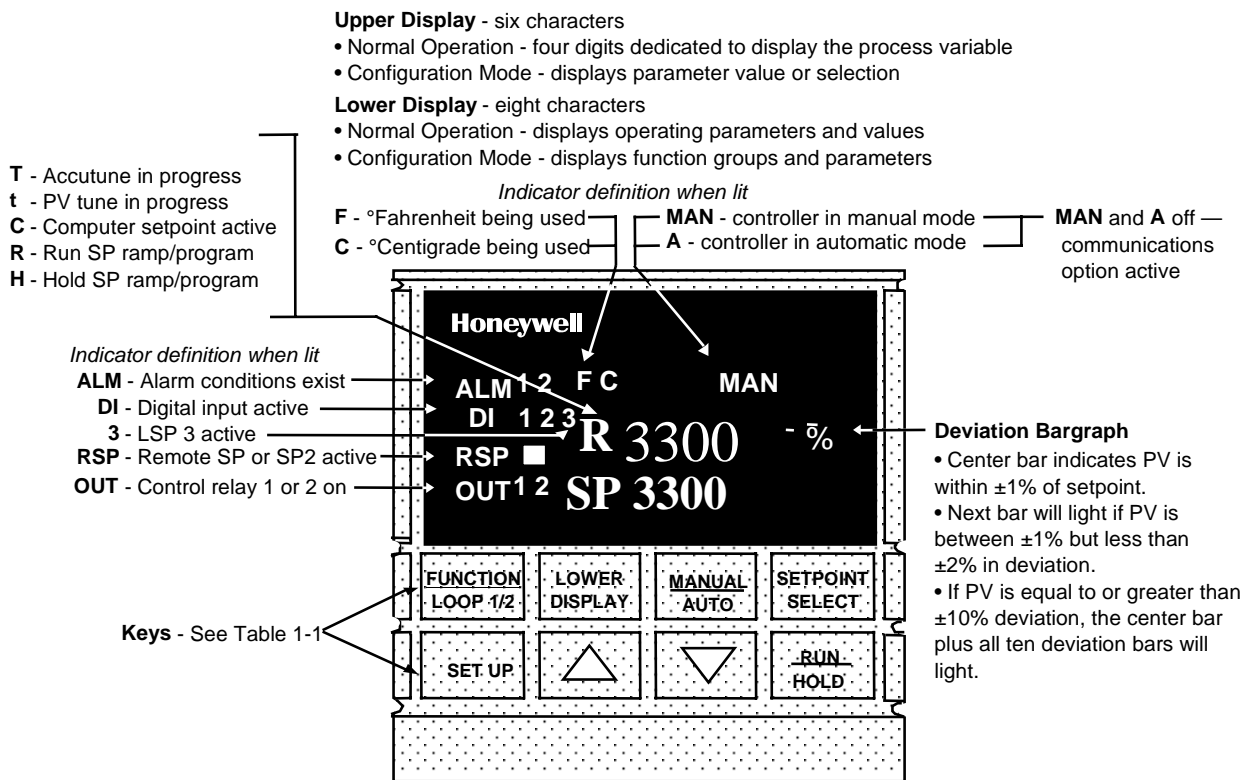

Figure 1-1 Operator Interface Displays and Indicators

1.3 Function Keys

Table 1-1 Function of Keys

Key	Function
SET UP	<ul style="list-style-type: none"> Places the controller in the Configuration Set Up group select mode. Sequentially displays Set Up groups and allows the FUNCTION key to display individual functions in each Set Up group.
<u>FUNCTION</u> LOOP 1/2	Used in conjunction with the SET UP key to select the individual functions of a selected Configuration Set Up group. .
LOWER DISPLAY	Selects an operating parameter to be shown in the lower display.
<u>MANUAL</u> AUTO	Alternately selects AUTO or MAN. .
SETPOINT SELECT	Hold key down to cycle through configured setpoints.
<u>RUN</u> HOLD	<ul style="list-style-type: none"> Alternate action switch initiates or holds the Setpoint Ramp or Setpoint Program. Acknowledges a latched alarm 1.
▲	Increases the selected parameter value.
▼	Decreases the selected parameter value.

2. Installation

2.1 Mounting

Physical Considerations

The controller can be mounted on either a vertical or tilted panel using the mounting kit supplied. Adequate access space must be available at the back of the panel for installation and servicing activities.

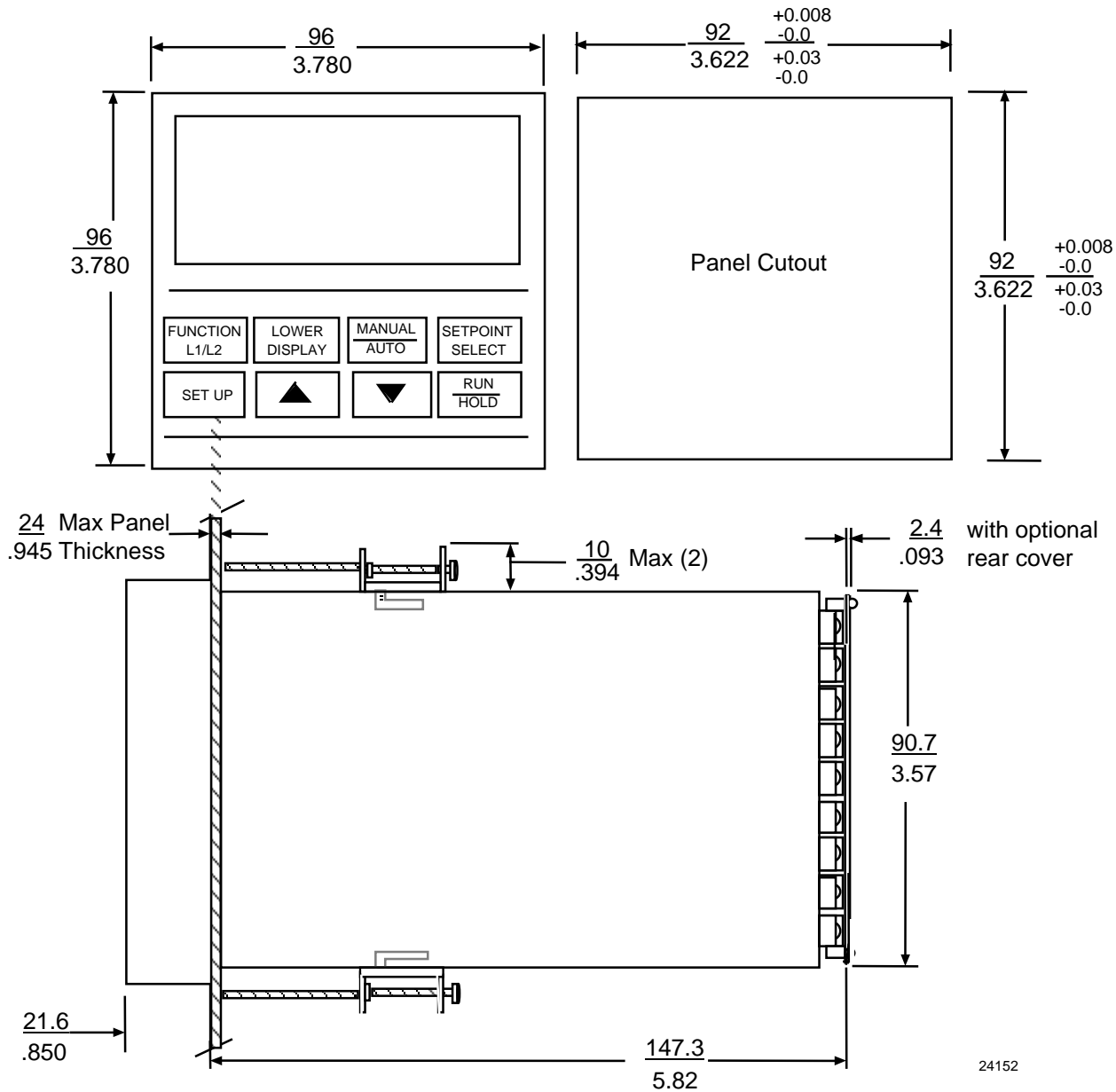

Mounting Method

Before mounting the controller, refer to the nameplate on the inside of the case and make a note of the model number. It will help later when selecting the proper wiring configuration.

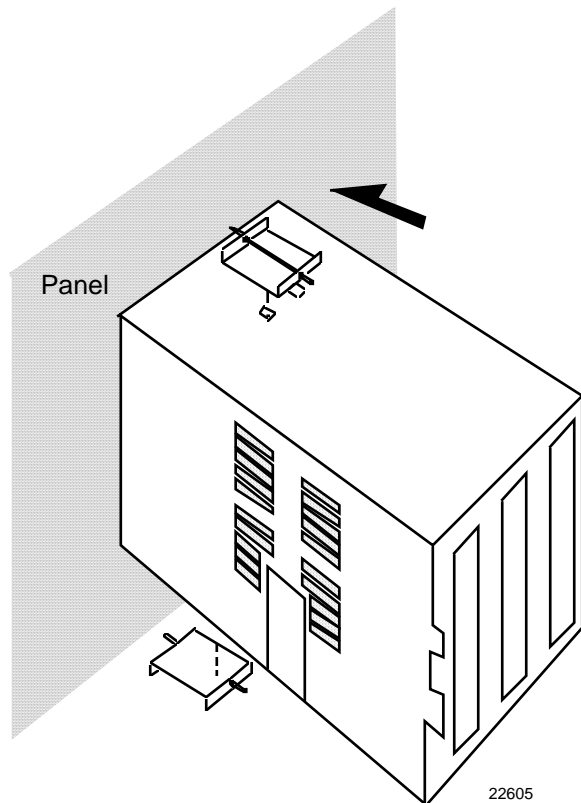

Remove the mounting kit from the shipping container, and install the kit as follows:

- Install the screws into the threaded holes of the clips.
- Insert the prongs of the clips into the two holes in the top and bottom of the case.
- Tighten both screws to secure the case against the panel.
- Carefully slide the chassis assembly into the case, press to close and tighten the screw. Replace the screw cover.

Figure 2-2 Mounting Method

2.2 Wiring

Electrical Considerations/Precautions

The controller is considered “rack and panel mounted equipment” per EN 61010-1, Safety Requirements for Electrical Equipment for Measurement, Control, and Laboratory Use, Part 1: General Requirements. Conformity with 72/23/EEC, the Low Voltage Directive requires the user to provide adequate protection against a shock hazard. The user shall install this controller in an enclosure that limits OPERATOR access to the rear terminals.

Controller Grounding

PROTECTIVE BONDING (grounding) of this controller and the enclosure in which it is installed shall be in accordance with National and local electrical codes. To minimize electrical noise and transients that may adversely affect the system, supplementary bonding of the controller enclosure to a local ground, using a No. 12 (4 mm²) copper conductor, is recommended.

Control/Alarm Circuit Wire Rating



The insulation of wires connected to the Control/Alarm terminals shall be rated for the highest voltage involved. Extra Low Voltage (ELV) wiring (input, current output, and low voltage Control/Alarm circuits) shall be separated from HAZARDOUS LIVE (>30 Vac, 42.4 Vpeak, or 60 Vdc) wiring per Table 2-1.

Electrical Noise Precautions

Electrical noise is composed of unabated electrical signals which produce undesirable effects in measurements and control circuits.

Digital equipment is especially sensitive to the effects of electrical noise. Your controller has built-in circuits to reduce the effect of electrical noise from various sources. Be sure to separate external wiring into bundles (see Table 2-1) and route the individual bundles through separate conduits or metal trays.

ATTENTION

For installation where high EMI/RFI noise cannot be avoided, we recommend you use shielded twisted pair wires for the signals in bundle 2.

Table 2-1 Permissible Wiring Bundling

Bundle No.	Wire Functions
1	<ul style="list-style-type: none"> • Line power wiring • Earth ground wiring • Control relay output wiring • Line voltage alarm wiring
2	Analog signal wire, such as: <ul style="list-style-type: none"> • Input signal wire (thermocouple, 4 to 20 mA, etc.) • 4-20 mA output signal wiring • Slidewire feedback circuit wiring • Digital input signals • Communications
3	<ul style="list-style-type: none"> • Low voltage alarm relay output wiring • Low voltage wiring to solid state type control circuits

Composite Wiring

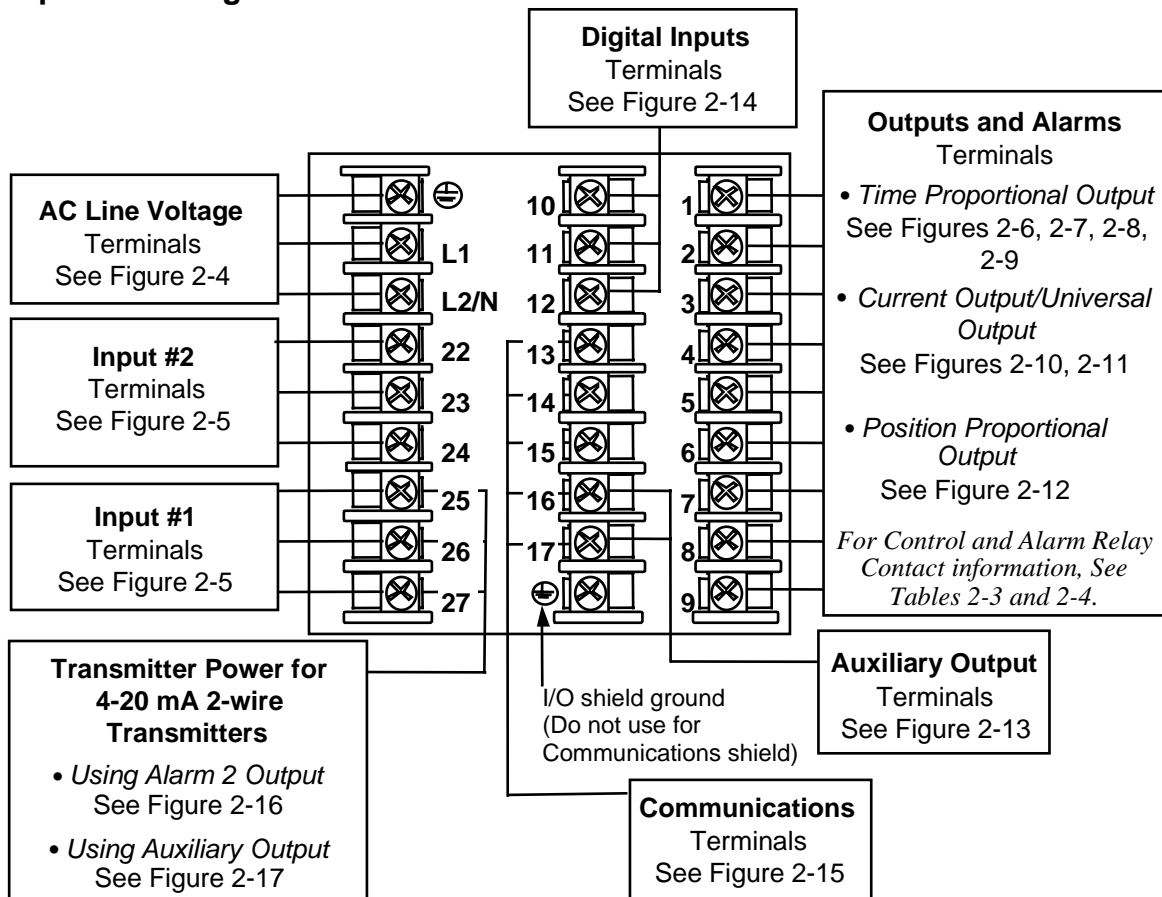

Figure 2-3 Composite Wiring Diagram

Line Voltage Wiring

This equipment is suitable for connection to 90-264 Vac or 24 Vac/dc, 50/60 Hz, power supply mains. It is the user's responsibility to provide a switch and non-time delay (North America), quick-acting, high breaking capacity, Type F, (Europe) 1/2 A, 250 V fuse(s) or circuit-breaker for 90-264 V; or 1 A, 125 V fuse or circuit breaker for 24 Vac/dc operation, as part of the installation. The switch or circuit-breaker should be located close to the controller, *within easy reach of the operator*. The switch or circuit-breaker should be marked as the disconnecting device for the controller (4 mm²).

CAUTION

Applying 90-264 Vac to a controller rated for 24 Vac/dc will severely damage the controller and is a fire and smoke hazard.

When applying power to multiple instruments, make sure that sufficient current is supplied. Otherwise, the instruments may not start up normally due to the voltage drop caused by the in-rush current.

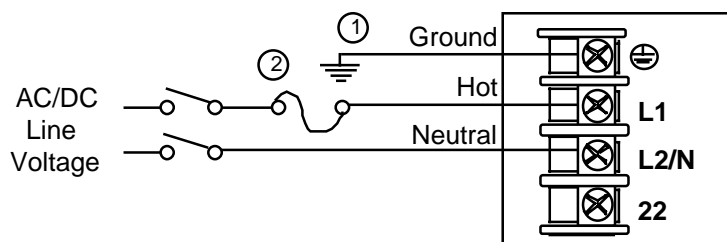

- ① PROTECTIVE BONDING (grounding) of this controller and the enclosure in which it is installed, shall be in accordance with National and local electrical codes. To minimize electrical noise and transients that may adversely affect the system, supplementary bonding of the controller enclosure to a local ground, using a No. 12 (4 mm²) copper conductor, is recommended.
- ② Provide a switch and non-time delay (North America), quick-acting, high breaking capacity, Type F (Europe), 1/2A, 250V fuse(s) or circuit-breaker for 90-264V; or 1A, 125V fuse or circuit breaker for 24 Vac/dc operation, as part of the installation.

Figure 2-4 Line Voltage Wiring

Input#1/Input #2

INPUT #2

Refer to Table 2-2 for Input 2 Jumper selections.

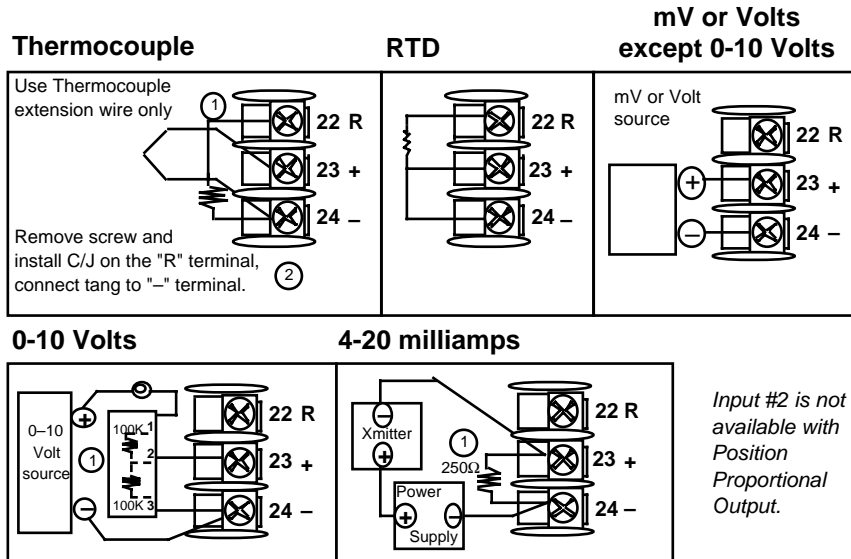

① The 250Ω load resistor for 4-20 mA or the voltage divider for 0-10 volts or the 500 ohm C/J compensation resistor is supplied with the controller when the input is specified. These items must be installed when you wire the controller before start-up.

INPUT #1 ③

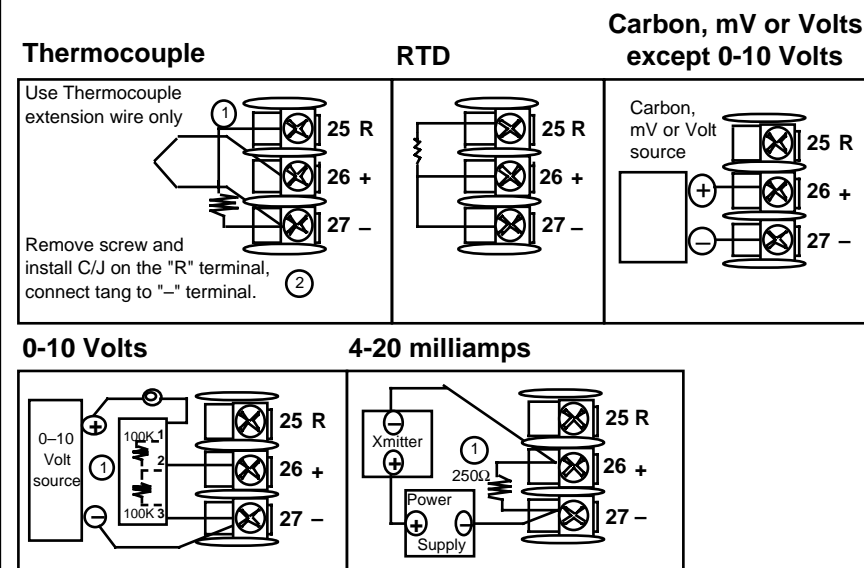

Figure 2-5 Input #1/#2 Connections

Input 2 Jumper

Table 2-2 Input 2 Jumper Selections

Jumper Location			
Jumper Position	W1	W2	
Input Types Available	Slidewire	Thermocouple, RTD, mV, Radiamatic, Carbon, Oxygen, 4-20 mA, 0-20 mA, 1-5 V, 0-5 V	

Time Proportional Output

The three types of Time Proportional outputs available on the UDC 3300 are shown in the following figures.

The Alarm wiring connections are the same for all three outputs.

For Control and Alarm Relay Contact information, see Table 2-3 and Table 2-4.

Figure 2-6 shows the Output and Alarm wiring connections for models with Electromechanical Relay Output.

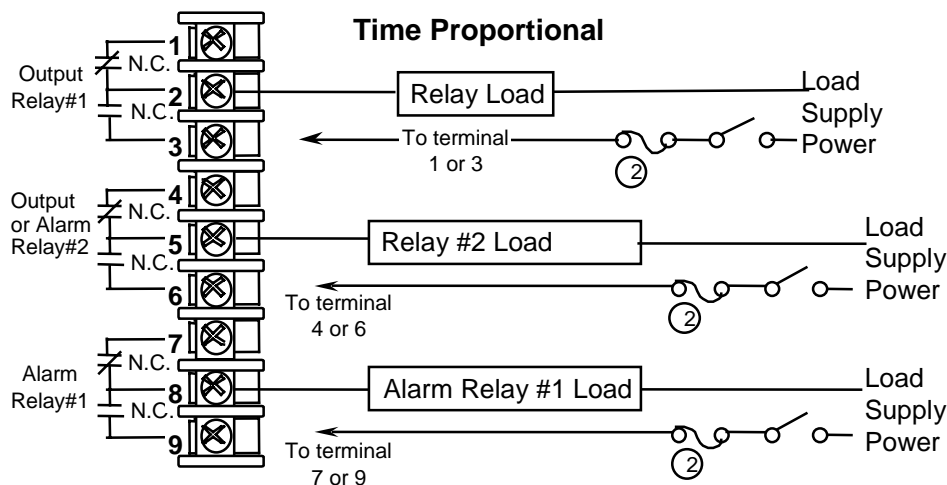

① Alarm #2 is not available with Time Proportional Duplex or Three Position Step Control or Position Proportional Control or Current/Time Duplex.

② Electromechanical relays are rated at 5 Amps @ 120Vac or 30 Vdc and 2.5 Amps at 240 Vac.

Customer should size fuses accordingly. Use FastBlo fuses only.

Figure 2-6 Electromechanical Relay Output – Model DC330X-EE-XXX

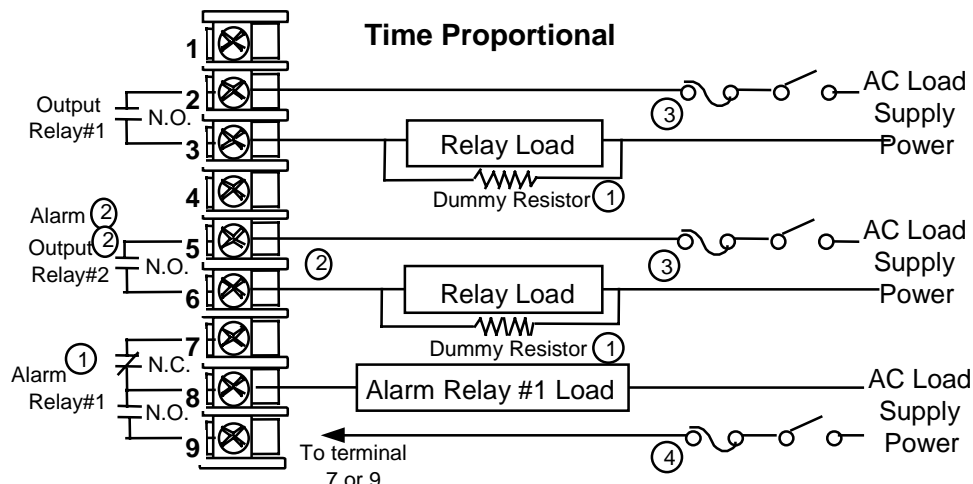

- ① If the load current is less than the minimum rated value of 20mA, there may be a residual voltage across both ends of the load even if the relay is turned off. Use a dummy resistor as shown to counteract this. The total current through the resistor and the load current must exceed 20mA.
- ② Alarm #2 not available with Time Proportional Duplex or Three Position Step Control or Position Proportional control.
- ③ Solid State relays are rated at 0.5 amps. Customer should size fuses accordingly. Use FastBlo fuses only.
- ④ Electromechanical relays are rated at 5 Amps @ 120Vac or 30 Vdc and 2.5 Amps at 240 Vac. Customer should size fuses accordingly. Use Fast Blo fuses only.

WARNING: Only connect Vac to solid state relays.

Figure 2-7 Solid State (SS) Relay Output — Model DC33X-AA-XX

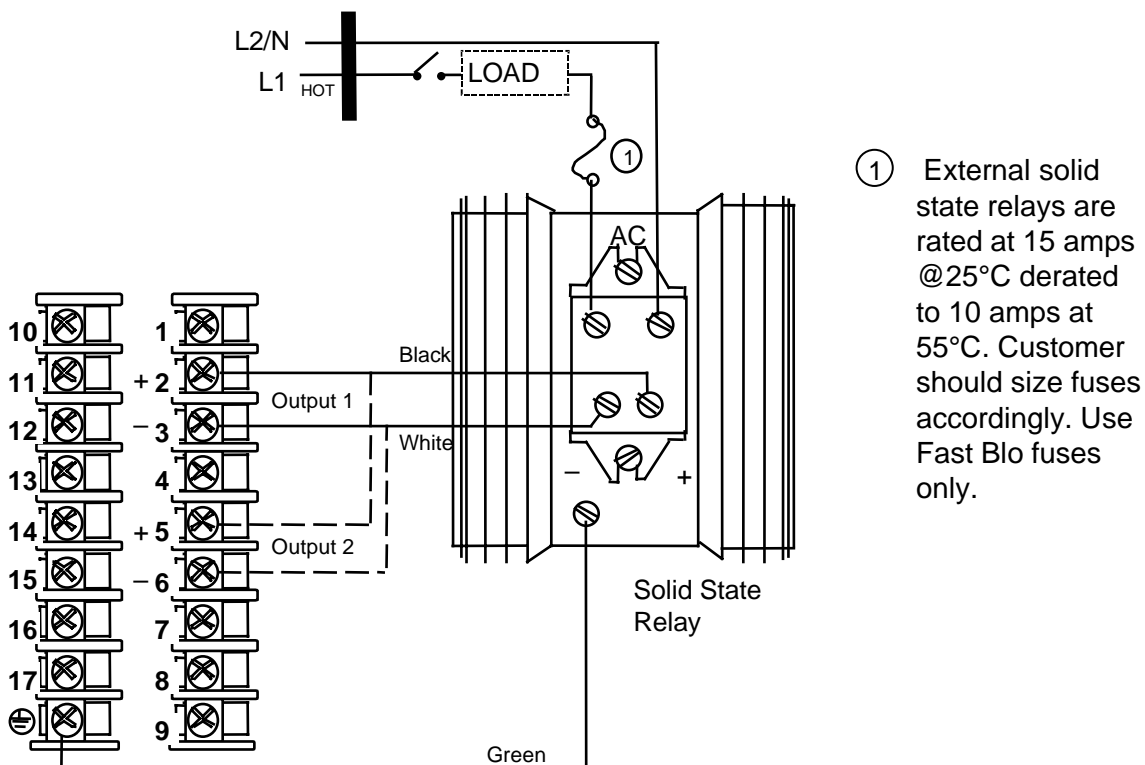
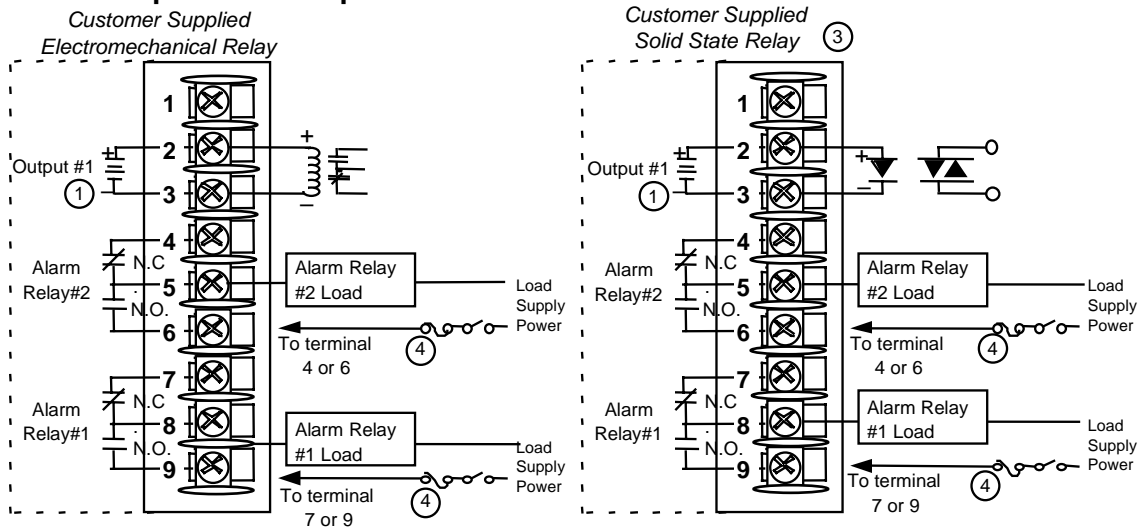
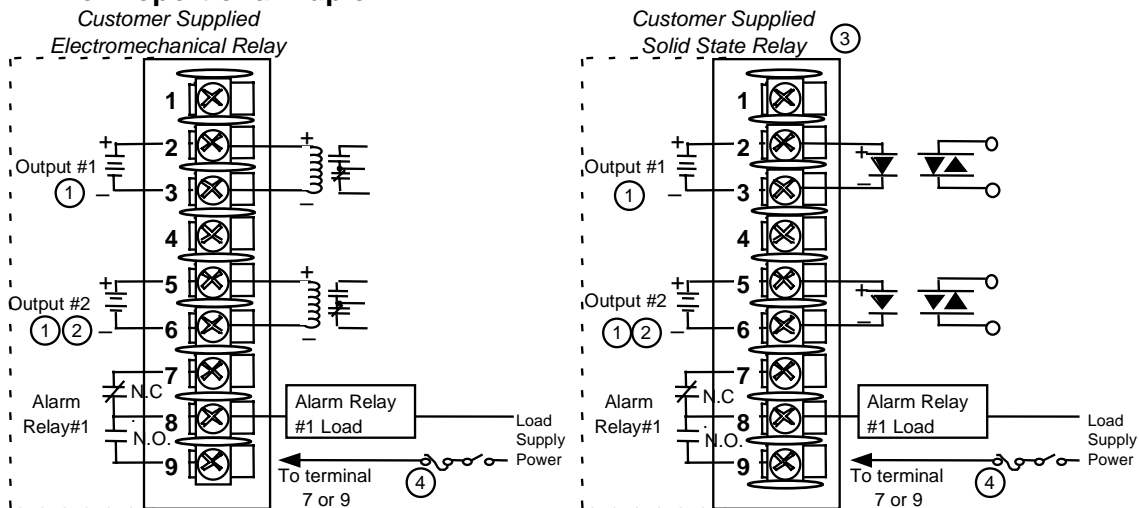

Figure 2-8 10-amp SS External Relay Output — Model DC330X-SS-XX

Time Proportional Simplex



Time Proportional Duplex



- ① **CAUTION** Open collector outputs are internally powered. Connecting an external supply will damage the controller. 24166
- ② Alarm #2 not available with Time Proportional Duplex or Three Position Step Control or Position Proportional control.
- ③ Can also use 10 amp solid state relay, Part Number 30756018-003
- ④ Electromechanical relays are rated at 5 Amps @ 120 Vac or 30 Vdc and 2.5 Amps at 240 Vac. Customer should size fuses accordingly. Use Fast Blo fuses only.

Figure 2-9 Open Collector Output — Model DC330X-TT-XXX

Current Output/Universal Output

Figure 2-10 shows the Output and Alarm wiring connections for models with Current Output and two-relay outputs (**Model DC330X-KE-XXX**).

See Table 2-3 for relay terminal connections for Output Algorithm selected.

For Duplex Current Output use Auxiliary Output for Output 2 (cool) (see Figure 2-14).

ATTENTION:
All current outputs are isolated from each other, case ground, and all inputs.

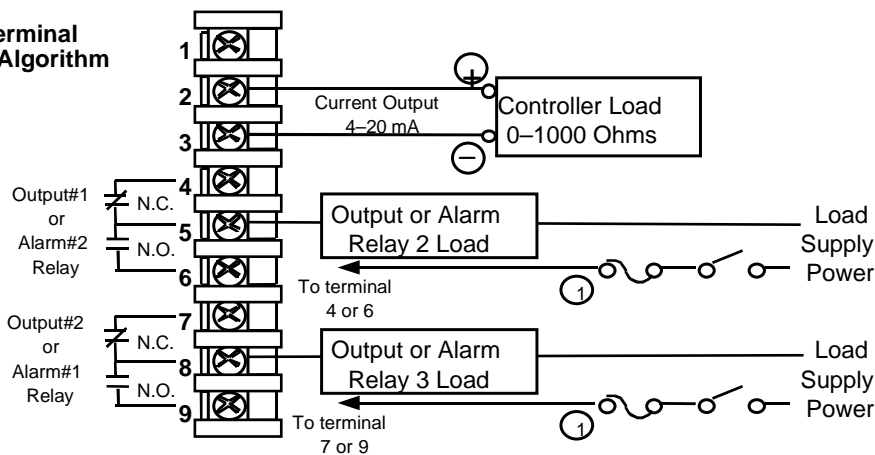

- ① Electromechanical relays are rated at 5 Amps @ 120 Vac or 2.5 Amps at 240Vac. Customer should size fuses accordingly. Use Fast Blo fuses only. Relays are NOT available on DC330X-C0-

Figure 2-10 Current Output Current/Time Duplex, Time/Current Duplex, Position Proportional or Three Position Step Control

Figure 2-11 shows the Output and Alarm wiring connections for models with a Current Output (Auxiliary Output) and three Relay Outputs (**Model DC330X-EE-2XX**).

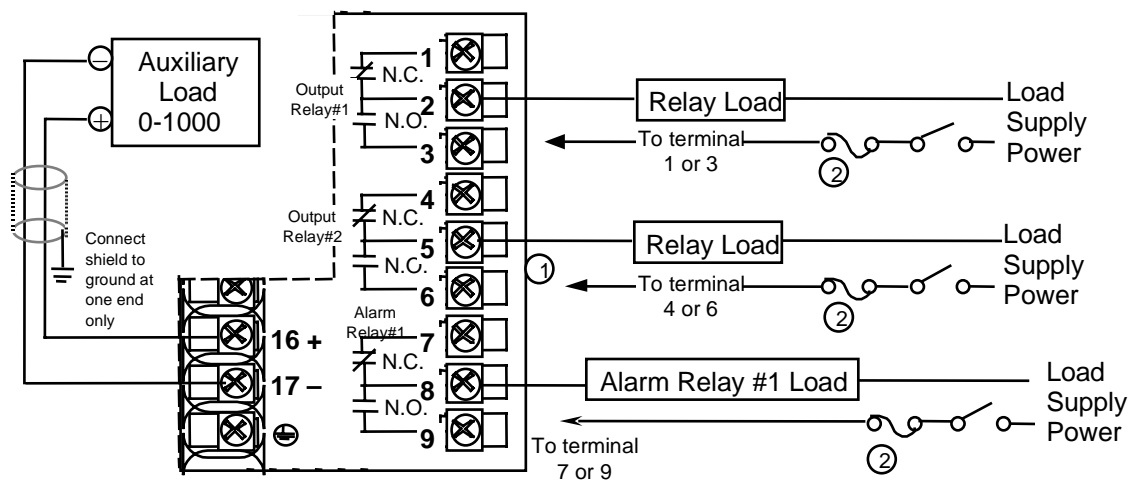

- ① Alarm #2 is not available with Time Proportional Duplex or Three Position Step Control or Position Proportional Control.
- ② Electromechanical relays are rated at 5 Amps @ 120 Vac or 2.5 Amps at 240 Vac. Customer should size fuses accordingly. Use Fast Blo fuses only.

All current outputs are isolated from each other, case ground, and all inputs. 24160

Figure 2-11 Auxiliary Output and Three-Relay Output

Position Proportional Output

Figure 2-12 shows models with Position Proportional Output (**Model DC330X-EE-XXX-X2**) or Three Position Step Control (**Model DC330X-AA-XXX-X2**).

Calibration

Position Proportional Output models must have the output calibrated after installation. **(See Appendix D.)**

Three Position Step models only require that the motor time be entered. Full calibration is not required.

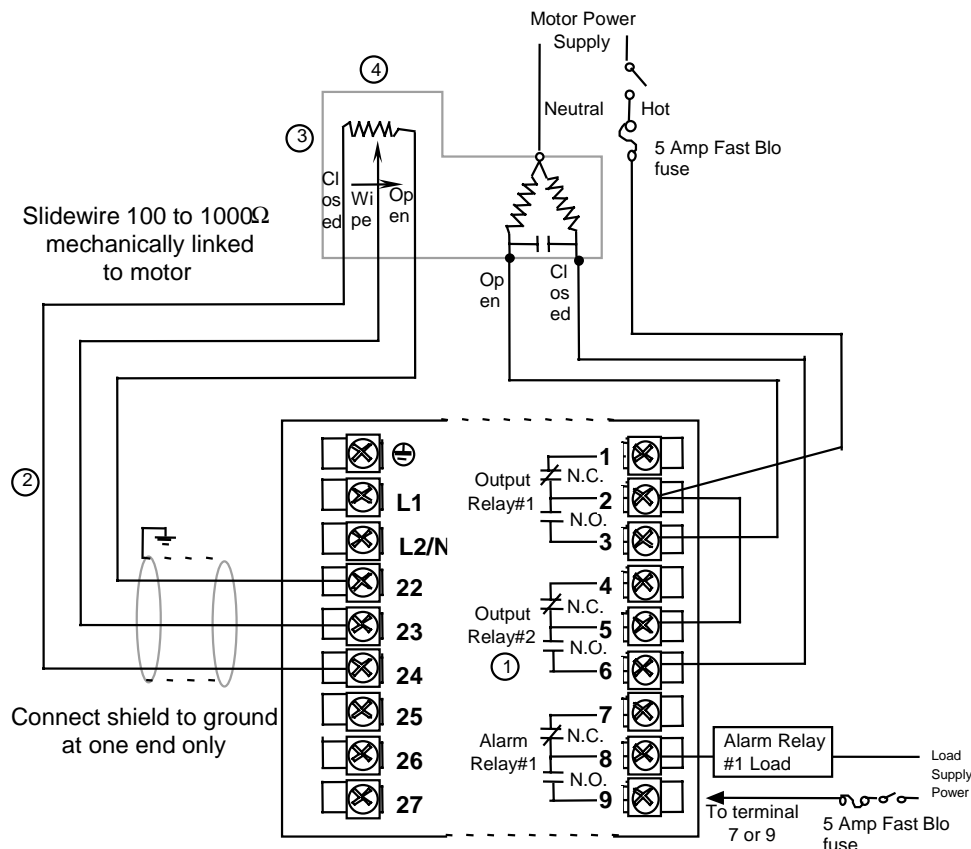

- ① Alarm #2 is not available with Position Proportional output or Three Position Step control.
- ② Do not run slidewire cable in the same conduit as AC power.
- ③ Electrical noise suppression may be required.
- ④ Slidewire input is not required for Three Position Step control but can be used for motor position indication.

**Figure 2-12 Position Proportional Output or Three Position Step—
Models DC330X-EE-XXX-X2, DC330X-AA-XXX-X2**

Auxiliary Output

For Duplex Current Output use Control Output for Output 1 (heat)

ATTENTION:
Both current outputs (control and auxiliary) are isolated from each other, case ground, and all inputs.

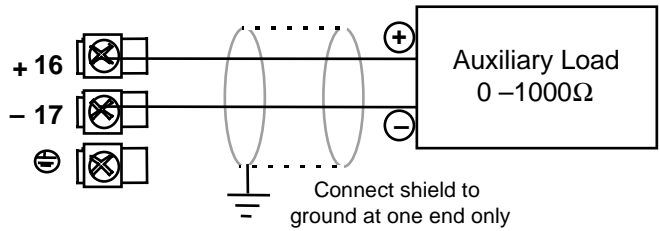

Figure 2-13 Auxiliary Output Connections—Models DC330X-XX-2XX, DC330X-XX-5XX

Digital Inputs

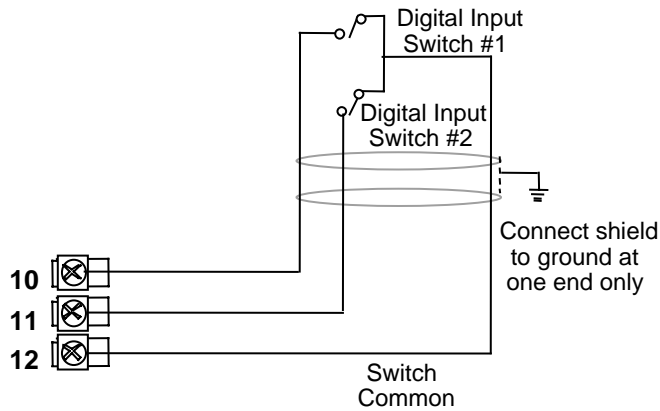

Figure 2-14 Digital Inputs Connections—Model DC330X-XX-XX3

Communications Option

The Communications option is available for RS422/485/ASCII or Modbus (**Model DC330X-XX-1XX or DC330X-XX-5XX**)—refer to Figure 2-15. Also refer to:

- Document #51-51-25-35 (RS422/485 ASCII) or
- Documents #51-52-25-66 and #51-52-25-70 (Modbus)

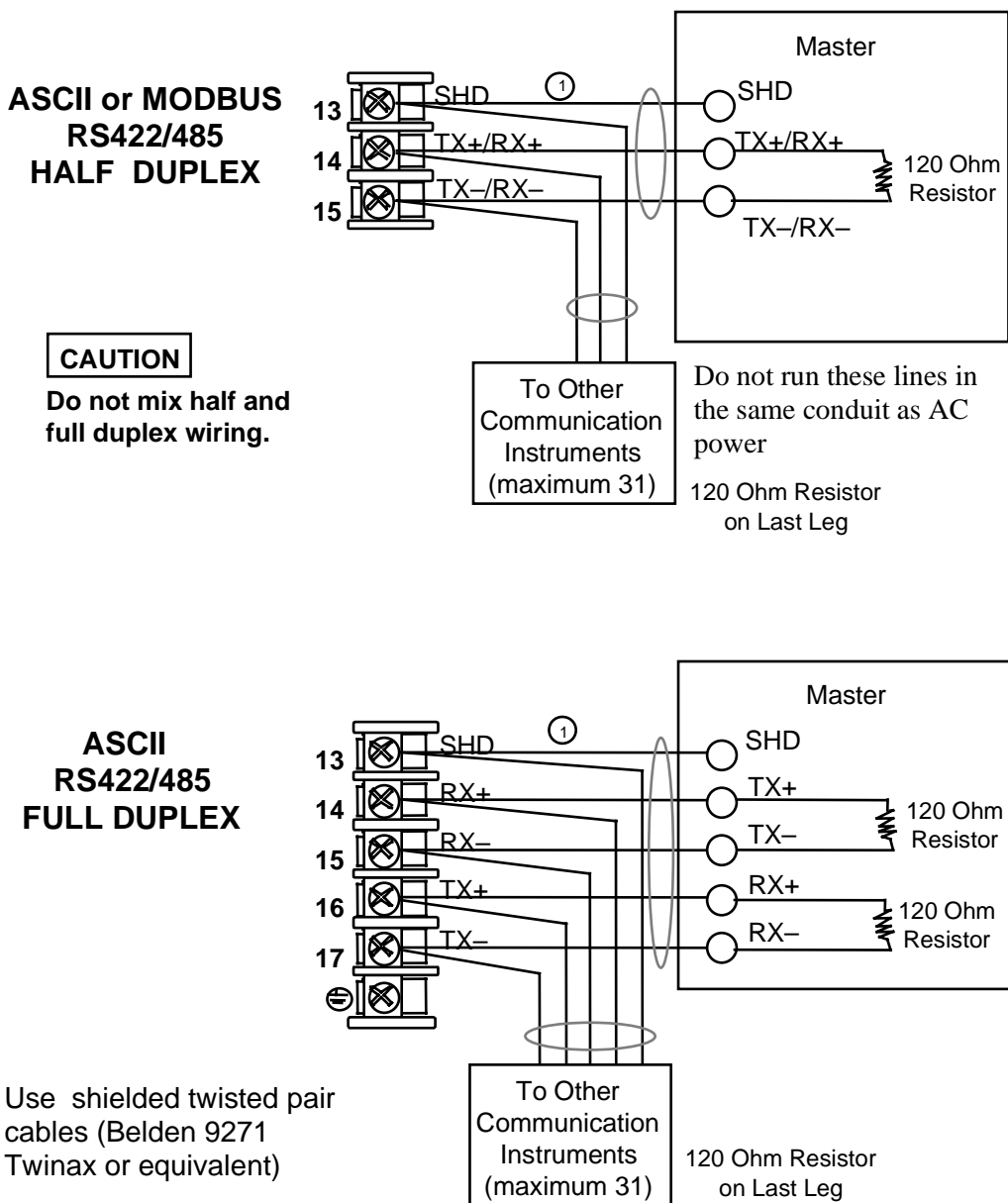

Figure 2-15 RS422/485/ASCII or Modbus Communications Option Connections

Transmitter Power for 4-20 mA 20 Wire Transmitter— Using Open Collector Alarm 2 Output

The wiring diagram example shown in Figure 2-16 (**Model DC330X-XT-XXX**) provides 30 Vdc at terminals 5 and 6 with the capability of driving up to 22 mA. If the transmitter terminal voltage must be limited to less than 30 volts, you can insert a zener diode between the positive transmitter terminal and terminal 5. For example, an IN4733A zener diode will limit the voltage at the transmitter to 25 Vdc.

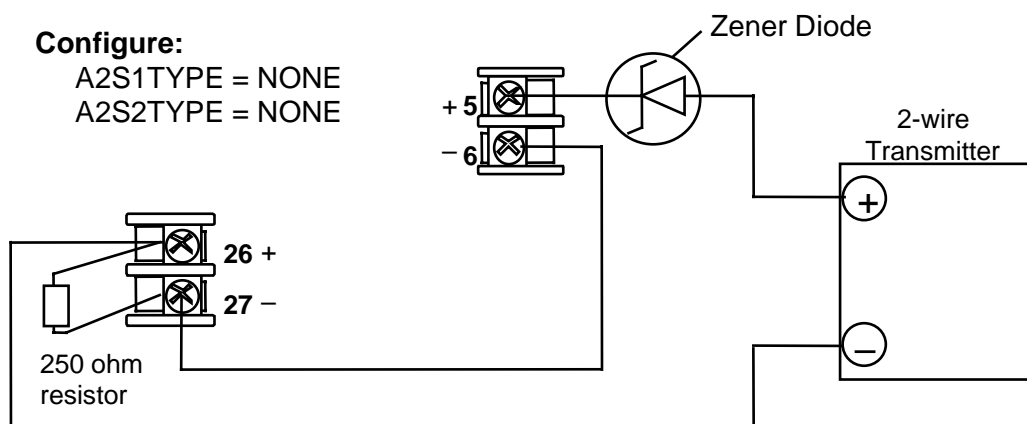

Figure 2-16 Transmitter Power for 4-20 mA 2-wire Transmitter Using Open Collector Alarm 2 Output—Model DC330X-XT-XXX

Transmitter power for 4-20 mA 20 wire Transmitter—Using Auxiliary Output

The wiring diagram example shown in Figure 2-17 (**Model DC330X-XX-2XX or DC330X-XX-5XX**) provides 30 Vdc at terminal 16 with the capability of driving up to 22 mA.

If the transmitter terminal voltage must be limited to less than 30 volts, you can insert a zener diode between the positive transmitter terminal and terminal 16. For example, an IN4733A zener diode will limit the voltage at the transmitter to 25 Vdc.

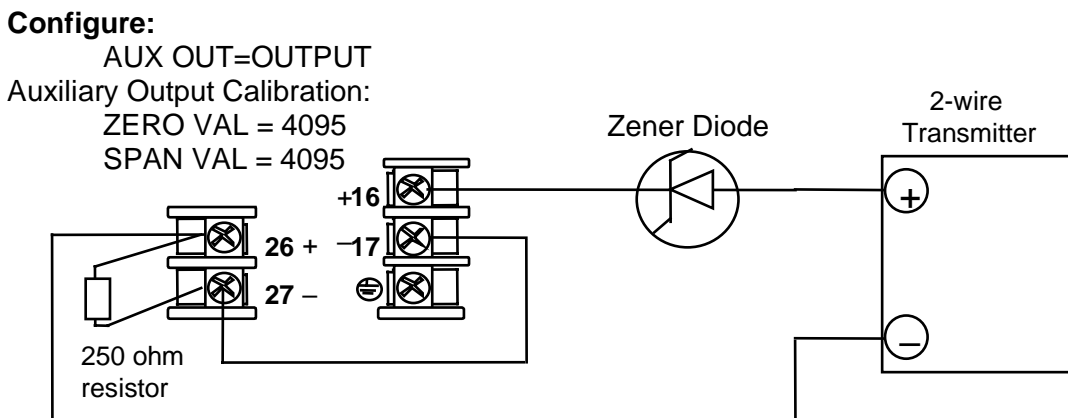

Figure 2-17 Transmitter Power for 4-20 mA 2-wire Transmitter Using Auxiliary Output—Model DC330X-XX-2XX or DC330X-XX-5XX

Control Relays

ATTENTION

Control relays operate in the standard control mode: i.e., energized when output state is on.

Table 2-3 Control Relay Contact Information

Unit Power	Control Relay Wiring	Control Relay Contact	#1 or #2 Output Indicator Status
Off	N.O.	Open	Off
	N.C.	Closed	
On	N.O.	Open Closed	Off On
	N.C.	Closed Open	Off On

Alarm Relays

ATTENTION

Alarms relays are designed to operate in a failsafe mode; i.e., de-energized during alarm state. This results in alarm actuation when power is OFF or when initially applied, until the unit completes self-diagnostics. If the unit loses power, the alarms will function.

Table 2-4 Alarm Relay Contact Information

Unit Power	Alarm Relay Wiring	Variable NOT in Alarm State		Variable in Alarm State	
		Relay Contact	Indicators	Relay Contact	Indicators
Off	N.O.	Open	Off	Open	Off
	N.C.	Closed		Closed	
On	N.O.	Closed	Off	Open	On
	N.C.	Open		Closed	

3. Configuration

3.1 Overview

The controller is pre-configured at the factory for typical controller settings for a heating process except the input type and output algorithm must be configured to match your process. The controller must also be tuned. See subsection 4.12.

To assist you in the configuration process, there are prompts that appear in the upper and lower displays. These prompts let you know what group of configuration data (Set Up prompts) you are working with and also, the specific parameters (Function prompts) associated with each group.

Figure 3-1 shows you an overview of the prompt hierarchy. As you will see, the configuration data is divided into 12 main Set Up groups plus prompts for calibration and prompts that show the status of the continuous background tests that are being performed.

Figure 3-1 Prompt Hierarchy

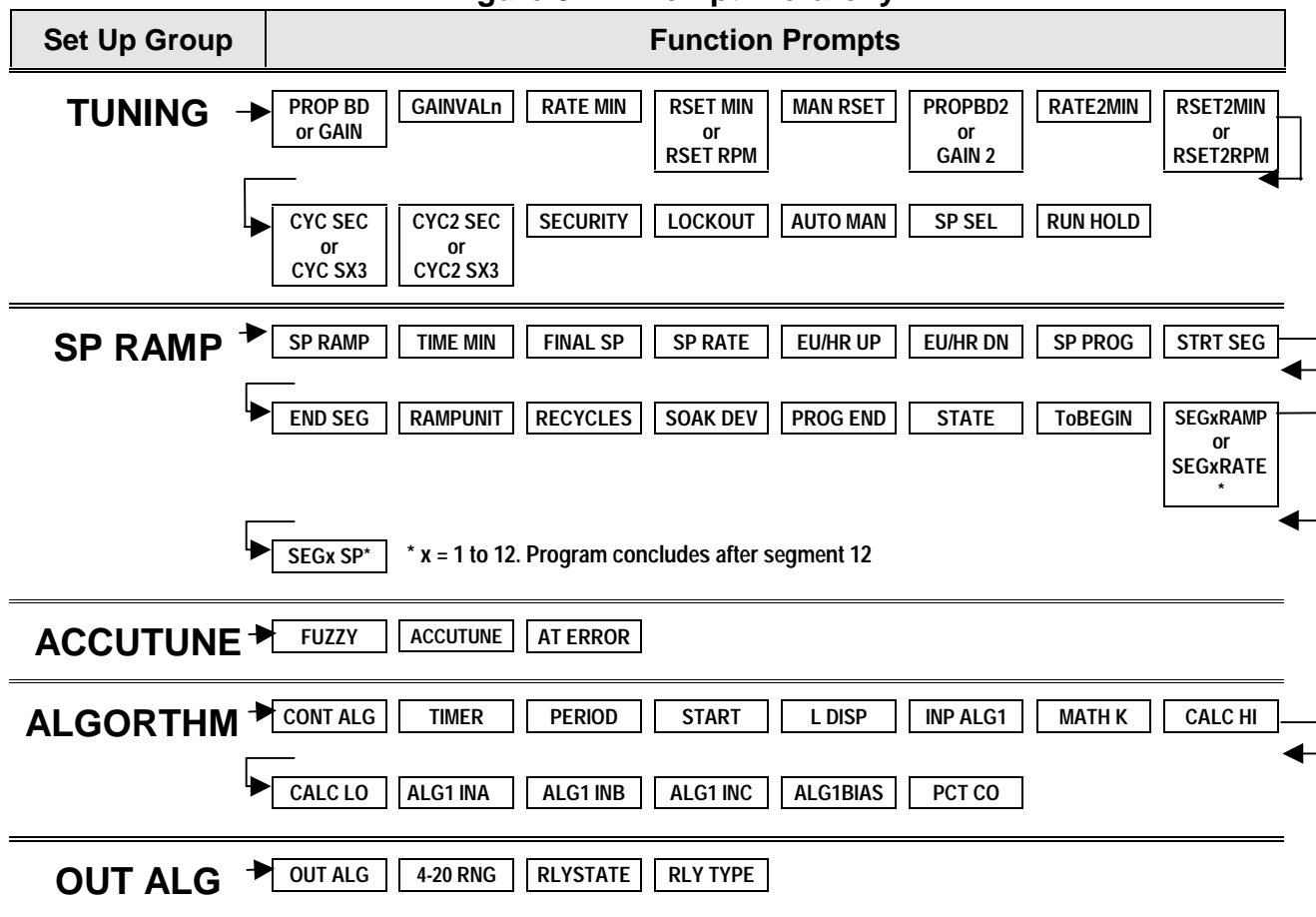

Set Up Group	Function Prompts
INPUT 1	<input type="checkbox"/> IN1 TYPE <input type="checkbox"/> XMITTER1 <input type="checkbox"/> IN1 HI <input type="checkbox"/> IN1 LO <input type="checkbox"/> RATIO 1 <input type="checkbox"/> BIAS IN1 <input type="checkbox"/> FILTER 1 <input type="checkbox"/> BURNOUT1
	<input type="checkbox"/> EMISSIV1
INPUT 2	<input type="checkbox"/> IN2 TYPE <input type="checkbox"/> XMITTER2 <input type="checkbox"/> IN2 HI <input type="checkbox"/> IN2 LO <input type="checkbox"/> RATIO 2 <input type="checkbox"/> BIAS IN2 <input type="checkbox"/> FILTER 2 <input type="checkbox"/> BURNOUT2
	<input type="checkbox"/> EMISSIV2
CONTROL	<input type="checkbox"/> PV SOURC <input type="checkbox"/> PID SETS <input type="checkbox"/> SW VALUE <input type="checkbox"/> LSP'S <input type="checkbox"/> RSP SRC <input type="checkbox"/> AUTOBIAS <input type="checkbox"/> SP TRACK <input type="checkbox"/> PWR MODE
	<input type="checkbox"/> PWR OUT <input type="checkbox"/> SP HiLIM <input type="checkbox"/> SP LoLIM <input type="checkbox"/> ACTION <input type="checkbox"/> OUT RATE <input type="checkbox"/> PCT/M UP <input type="checkbox"/> PCT/M DN <input type="checkbox"/> OUTHILIM
	<input type="checkbox"/> OUTLoLIM <input type="checkbox"/> I Hi LIM <input type="checkbox"/> I Lo LIM <input type="checkbox"/> DROPOFF <input type="checkbox"/> DEADBAND <input type="checkbox"/> OUT HYST <input type="checkbox"/> FAILMODE <input type="checkbox"/> FAILSAFE
	<input type="checkbox"/> MAN OUT <input type="checkbox"/> AUTO OUT <input type="checkbox"/> PBoR GAIN <input type="checkbox"/> MINor RPM
OPTIONS	<input type="checkbox"/> AUX OUT <input type="checkbox"/> 4 mA VAL <input type="checkbox"/> 20mA VAL <input type="checkbox"/> DIG IN 1 <input type="checkbox"/> DIG1 COM <input type="checkbox"/> DIG IN 2 <input type="checkbox"/> DIG2 COM
COM	<input type="checkbox"/> ComSTATE <input type="checkbox"/> Com ADDR <input type="checkbox"/> SHEDENAB <input type="checkbox"/> SHEDTIME <input type="checkbox"/> PARITY <input type="checkbox"/> BAUD <input type="checkbox"/> DUPLEX <input type="checkbox"/> WSFLOAT
	<input type="checkbox"/> TXDELAY <input type="checkbox"/> SHEDMODE <input type="checkbox"/> SHEDSP <input type="checkbox"/> UNITS <input type="checkbox"/> CSP RATO <input type="checkbox"/> CSP BIAS <input type="checkbox"/> LOOPBACK
ALARMS	<input type="checkbox"/> A1S1 VAL <input type="checkbox"/> A1S2 VAL <input type="checkbox"/> A2S1 VAL <input type="checkbox"/> A2S2 VAL <input type="checkbox"/> A1S1TYPE <input type="checkbox"/> A1S2 TYPE <input type="checkbox"/> A2S1TYPE <input type="checkbox"/> A2S2TYPE
	<input type="checkbox"/> A1S1 H L <input type="checkbox"/> A1S1 EV <input type="checkbox"/> A1S2 H L <input type="checkbox"/> A1S2 EV <input type="checkbox"/> A2S1 H L <input type="checkbox"/> A2S1 EV <input type="checkbox"/> A2S2 H L <input type="checkbox"/> A2S2 EV
	<input type="checkbox"/> AL HYST <input type="checkbox"/> ALM OUT1 <input type="checkbox"/> BLOCK
DISPLAY	<input type="checkbox"/> DECIMAL <input type="checkbox"/> TEMPUNIT <input type="checkbox"/> PWR FREQ <input type="checkbox"/> RATIO 2 <input type="checkbox"/> LANGUAGE
CALIB	<input type="checkbox"/> USED FOR FIELD CALIBRATION
STATUS	<input type="checkbox"/> VERNON <input type="checkbox"/> FAILSAFE <input type="checkbox"/> RAM TEST <input type="checkbox"/> CONFTEST <input type="checkbox"/> CALTEST <input type="checkbox"/> FACT CRC

3.2 Configuration Procedure

Each of the Set Up groups and their functions are pre-configured at the factory. The factory settings are shown in Table 3-2 through Table 3-13. Follow the procedure in Table 3-1 if you want to make changes to any of these selections or values. Record your selections on the Configuration Record Sheet found in Appendix C.

Table 3-1 Configuration Procedure

Step	Operation	Press	Result
1	Select Set Up mode	SET UP	<i>Upper Display:</i> SET UP <i>Lower Display:</i> TUNING (This is the first Set Up group title.)
2	Select any Set Up group	SET UP	Sequentially displays the other Set Up group titles. You can also use the [▲] [▼] keys to scan the Set Up groups in both directions. Stop at the Set Up group title that describes the group of parameters you want to configure. Then proceed to the next step.
3	Select a Function parameter	FUNCTION	<i>Upper Display:</i> Shows the current value or selection for the first Function prompt of the selected Set Up group. <i>Lower Display:</i> Shows the first Function prompt within that Set Up group. Sequentially displays the other function prompts of the selected Set Up group. Stop at the function prompt that you want to change, then proceed to the next step.
4	Change the value or selection	▲ or ▼	Increments or decrements the value or selection that appears for the selected function. If the display flashes, you are trying to make an unacceptable entry.
5	Enter the value or selection	FUNCTION or SET UP	This key selects another Function prompt. This key selects another Set Up group. The value or selection you have made will be entered into memory after another key is pressed.
6	Exit Configuration	LOWER DISPLAY	Exits configuration mode and returns the controller to the same state it was in immediately preceding entry into the Set Up mode. It stores any changes you have made.

3.3 Loop 1 Tuning Parameters Set Up Group

Table 3-2 Tuning Group Function Prompts

Function Prompt Lower Display	Function Name	Selections or Range of Setting Upper Display	Factory Setting
PROP BD or GAIN	Proportional Band or Gain	0.1 to 9999% 0.001 to 1000	-- 1.000
or GAINVALn	or Gain Value being used by Gain Scheduling when enabled	Read Only	--
RATE MIN	Rate in Minutes	0.00 to 10.00 minutes	0.00
RSET MIN or RSET RPM	Reset in minutes/repeat or Reset in repeats/minute	0.02 to 50.00	1.00 --
MAN RSET	Manual Reset	-100 to 100% output	0
PROPBD2 or GAIN 2	Proportional Band 2 or Gain 2	0.1 to 9999% 0.001 to 1000	-- 1.000
RATE2MIN	Rate 2 in Minutes	0.00 to 10.00 minutes	0.00
RSET2MIN or RSET2RPM	Reset 2 in minutes/repeat or Reset 2 in repeats/minute	0.02 to 50.00	1.00 --
CYC SEC or CYC SX3	Cycle Time (Heat)	1 to 120	20
CYC2 SEC or CYC2 SX3	Cycle Time (Cool)	1 to 120	20
SECURITY	Security Code	0 to 4095	0

Function Prompt Lower Display	Function Name	Selections or Range of Setting Upper Display	Factory Setting
LOCKOUT	Configuration Lockout	NONE CALIB + CONF + VIEW MAX	CALIB
AUTO MAN	Manual/Auto Key Lockout	DISABL ENABLE	ENABLE
SP SEL	Setpoint Select Key Lockout	DISABL ENABLE	ENABLE
RUN HOLD	Run/Hold Key Lockout	DISABL ENABLE	ENABLE

3.4 SP Ramp, SP Rate, or SP Programming Set Up Group

Table 3-3 SP Ramp Function Prompts

Function Prompt Lower Display	Function Name	Selections or Range of Setting Upper Display	Factory Setting
<i>If SP Rate and SP Programming are disabled</i>			
SP RAMP	Single Setpoint Ramp Selection	DISABL ENABLE	DISABL
TIME MIN	Single Setpoint Ramp Time (SP Ramp enabled)	0 to 255 minutes	3
FINAL SP	Single Setpoint Final Setpoint (SP Ramp enabled)	Enter a value within the setpoint limits.	1000
<i>If SP Ramp and SP Programming are disabled</i>			
SP RATE	Setpoint Rate	DISABL ENABLE	DISABL
EU/HR UP	Rate Up Value for Loop 1 (SP Rate enabled)	0 to 9999 in engineering units per hour	0
EU/HR DN	Rate Down Value for Loop 1 (SP Rate enabled)	0 to 9999 in engineering units per hour	0
<i>If SP Ramp and SP Rate are disabled</i>			
SP PROG* *requires SP Program option	Setpoint Ramp/Soak Programming	DISABL ENABLE SP PROG must be enabled to view the remaining prompts.	DISABL
STRT SEG	Start Segment Number	1 to 11 (odd segment number only)	—
END SEG	End Segment Number	2 to 12 Always end in a soak segment (2, 4, ... 12)	—
RAMPUNIT	Engineering Units for Ramp Segments	TIME (hours.minutes) EU/MIN (engineering units/minute) EU/HR (engineering units/hour)	TIME
RECYCLES	Number of Program Recycles	0 to 99 recycles	—

Function Prompt Lower Display	Function Name	Selections or Range of Setting Upper Display	Factory Setting
SOAK DEV	Guaranteed Soak Deviation Value	0 to 99 The number selected will be the PV value (in engineering units) above or below the setpoint outside of which the timer halts.	—
PROG END	Program Termination State	LASTSP (Hold at last setpoint in the program) F SAFE (Manual mode/Failsafe output)	—
STATE	Program State at Program End	DISABL HOLD	—
KEYRESET	Reset SP Program	DISABL TOBEGN RERUN	DISABL
HOT START	Hot Start	DISABL ENAB	DISABL
SEG1RAMP or SEG1RATE	Segment #1 Ramp Time or Segment #1 Ramp Rate	0-99 hours.0-59 minutes Engineering units/minute or Engineering units/hour Select TIME, EU/MIN, or EU/HR at prompt RAMPUNIT. All ramps will use the same selection.	—
SEG2 SP	Segment #2 Soak Setpoint Value	Within the Setpoint limits	—
SEG2TIME	Segment #2 Soak Duration	0-99 hours.0-59 minutes	—
SEG 3, 5, 7, 9 & 11 RAMP	Same as above	Selections are same as above.	—
SEG 3, 5, 7, 9, & 11 RATE			
SEG 4, 6, 8, 10 & 12 SP			
SEG 4, 6, 8, 10 & 12 TIME			

3.5 Accutune Set Up Group

Table 3-4 Accutune Group Function Prompts

Function Prompt Lower Display	Function Name	Selections or Range of Setting Upper Display	Factory Setting
FUZZY	Fuzzy Overshoot Suppression	DISABL ENABLE	DISABL
ACCUTUNE	Accutune	DISABL TUNE (Demand Tuning)	DISABL
AT ERROR	Accutune Error Codes	Read Only RUNING (Accutune process in operation) NONE OUTLIM IDFAIL ABORT LOW PV	--

3.6 Algorithm Data Set Up Group

Table 3-5 Algorithm Group Function Prompts

Function Prompt Lower Display	Function Name	Selections or Range of Setting Upper Display	Factory Setting
CONT ALG	Control Algorithm	ON-OFF PID A PID B PD+MR 3PSTEP	PID A
TIMER	Timer Enable/Disable	ENABLE DISABL	DISABL
PERIOD	Timeout Period	00:00 to 99:59	00:01
START	Start Initiation	KEY (Run/Hold key) ALARM2	KEY
L DISP	Lower Display Selection	TI REM (time remaining) E time (elapsed time)	TI REM

Function Prompt Lower Display	Function Name	Selections or Range of Setting Upper Display		Factory Setting
INP ALG1	Input 1 Algorithm ATTENTION All Input Algorithms operate in engineering units except feedforward which operates in percent of output units. PV or RSP source in the Control Set Up group must be set to IN AL1.	NONE W AVG F FWRD FFWDMu CARB A CARB B	CARB C CARB D FCC DEW PT OXYGEN	NONE
MATH K	Weighted Average Ratio or K Constant for Math Selections	0.001 to 1000 floating		--
CALC HI	Calculated Variable High Scaling Factor for Input Algorithm	-999. to 9999. floating (in engineering units)		--
CALC LO	Calculated Variable Low Scaling Factor for Input Algorithm	-999. to 9999. floating (in engineering units)		--
ALG1 INA	Input Algorithm 1 Input A Selection	INP 1 INP 2 LP1OUT IN AL1		--
ALG1 INB	Input Algorithm 1 Input B Selection	INP 1 INP 2 LP1OUT IN AL1		--
ALG1 INC	Input Algorithm 1 Input C Selection	NONE INP 1 INP 2 LP1OUT IN AL1		--
PCT CO	Percent Carbon Monoxide	0.020 to 0.350 (fractional percent of CO)		0.200
ALG1BIAS	Input Algorithm 1 Bias	-999 to 9999 floating (in engineering units)		0.000

3.7 Output Algorithm Parameters Set Up Group

Table 3-6 Output Algorithm Group Function Prompts

Function Prompt Lower Display	Function Name	Selections or Range of Setting Upper Display	Factory Setting
OUT ALG	Loop 1 Output Algorithm	TIME Time Simplex CURRNT Current Simplex POSITN Position Proportional TIME D Time Duplex CUR D Current Duplex CUR TI Current /Time Duplex TI CUR Time/Current Duplex	CURRNT
4-20 RNG	Current Duplex Range	100PCT 50 PCT	100PCT
RLYSTATE	Digital Output State at 0% Output	1OF2OF (Output relays 1 and 2 are both de-energized) 1ON2OF (Output relay 1 is energized, output relay 2 is de-energized) 1OF2ON (Output relay 1 is de-energized, output relay 2 is energized) 1ON2ON (Output relays 1 and 2 are both energized)	1OF2ON
RLY TYPE	Relay Cycle Time Increments	MECHAN (Cycle time in one second increments) SOL ST (Cycle time in 1/3 second increments: 1 = .33 seconds, 120 = 40 seconds)	MECHAN

3.8 Input 1 Parameters Set Up Group

Table 3-7 Input 1 Group Function Prompts

Function Prompt Lower Display	Function Name	Selections or Range of Setting Upper Display		Factory Setting
IN1 TYPE	Input 1 Actuation Type <i>For Input Range Minimum and Maximum see Appendix E</i>	DISABL	W TC H	0-10mV
		B TC	W TC L	
		E TC H	100 PT	
		E TC L	100 LO	
		J TC H	200 PT	
		J TC L	500 PT	
		K TC H	RAD RH	
		K TC L	RAD RI	
		NNM H	0-20mA	
		NNM L	4-20mA	
		NM90 H	0-10mV	
		NM90 L	0-50mV	
		NIC TC	0-5 V	
		R TC	1-5 V	
		S TC	0-10 V	
		T TC H	CARBON	
		T TC L	OXYGEN	
XMITTER1	Transmitter Characterization	B TC	S TC	LINEAR
		E TC H	T TC H	
		E TC L	T TC L	
		J TC H	W TC H	
		J TC L	W TC L	
		K TC H	100 PT	
		K TC L	100 LO	
		NNM H	200 PT	
		NNM L	500 PT	
		NM90 H	RAD RH	
		NM90 L	RAD RI	
		NIC TC	LINEAR	
R TC	SQROOT			
IN1 HI	Input 1 High Range Value (Linear Inputs only)	-999. to 9999. floating (in engineering units)		1000
IN1 LO	Input 1 Low Range Value (Linear Inputs only)	-999. to 9999. floating (in engineering units)		0
RATIO 1	Input 1 Ratio	-20.00 to 20.00 (floats to 3 decimal places)		1.000
BIAS IN1	Input 1 Bias	-999. to 9999. (in engineering units)		0
FILTER 1	Input 1 Filter	0 to 120 seconds		1
BURNOUT1	Burnout Protection	NONE	DOWN	NONE
		UP	NO_FS	
EMISSIV1	Emissivity	0.01 to 1.00		0.00

3.9 Input 2 Parameters Set Up Group

Table 3-8 Input 2 Group Function Prompts

Function Prompt Lower Display	Function Name	Selections or Range of Setting Upper Display			Factory Setting
IN2 TYPE	Input 2 Actuation Type <i>For Input Range Minimum and Maximum see Appendix E</i>	DISABL	NM90 L	500 PT	0-10mV
		B TC	NIC TC	RAD RH	
		E TC H	R TC	RAD RI	
		E TC L	S TC	0-20mA	
		J TC H	T TC H	4-20mA	
		J TC L	T TC L	0-10mV	
		K TC H	W TC H	0-50mV	
		K TC L	W TC L	0-5 V	
		NNM H	100 PT	1-5 V	
		NNM L	100 LO	0-10 V	
		NM90 H	200 PT	SLIDEW	
XMITTER2	Transmitter Characterization	B TC	S TC		LINEAR
		E TC H	T TC H		
		E TC L	T TC L		
		J TC H	W TC H		
		J TC L	W TC L		
		K TC H	100 PT		
		K TC L	100 LO		
		NNM H	200 PT		
		NNM L	500 PT		
		NM90 H	RAD RH		
		NM90 L	RAD RI		
		NIC TC	LINEAR		
		R TC	SQROOT		
IN2 HI	Input 2 High Range Value (Linear Inputs only)	-999. to 9999. floating (in engineering units)			1000
IN2 LO	Input 2 Low Range Value (Linear Inputs only)	-999. to 9999. floating (in engineering units)			0
RATIO 2	Input 2 Ratio	-20.00 to 20.00			1.000
BIAS IN2	Input 2 Bias	-999. to 9999. (in engineering units)			0
FILTER 2	Input 2 Filter	0 to 120 seconds			1
BURNOUT2	Burnout Protection	NONE UP	DOWN NO_FS		NONE
EMISSIV2	Emissivity	0.01 to 1.00			0.00

3.10 Loop 1 Control Parameters Set Up Group

Table 3-9 Control Group Function Prompts

Function Prompt Lower Display	Function Name	Selections or Range of Setting Upper Display		Factory Setting
PV SOURC	Process Variable Source	INP 1 INP 2	IN AL1	INP 1
PID SETS	Tuning Parameter Sets	1 ONLY 2KEYBD 2PV SW 2SP SW		1 ONLY
SW VALUE	Automatic Switchover Value	Value in engineering units within PV or SP range limits		0.00
LSP'S	Local Setpoint Source	1 ONLY TWO THREE (Selection automatically disables RSP SRC)		1 ONLY
RSP SRC	Remote Setpoint Source	NONE INP 2	IN AL1	NONE
AUTOBIAS	Automatic Bias	ENABLE DISABL		DISABL
SP TRACK	Local Setpoint Tracking	NONE PV RSP		NONE
PWR MODE	Power Up Mode Recall	MANUAL A LSP A RSP AM SP AM LSP		MANUAL
PWR OUT	TPSC Output Start-up Mode	LAST F'SAFE		LAST
SP HiLIM	Setpoint High Limit	0 to 100% of span input in engineering units		1000
SP LoLIM	Setpoint Low Limit	0 to 100% of span input in engineering units		0
ACTION	Control Output Direction	DIRECT REVRSE		REVRSE
OUT RATE	Output Change Rate	ENABLE DISABL Does not apply to 3 Position Step Control algorithm.		DISABL
PCT/M UP	Output Rate Up Value	0 to 9999% per minute		0

Configuration

Function Prompt Lower Display	Function Name	Selections or Range of Setting Upper Display	Factory Setting
PCT/M DN	Output Rate Down Value	0 to 9999% per minute	0
OUTHILIM	High Output Limit	-5.0 to 105% of output	100
OUTLoLIM	Low Output Limit	-5.0 to 105% of output	0.0
I Hi LIM	High Reset Limit	Within the range of output limits	100.0
I Lo LIM	Low Reset Limit	Within the range of output limits	0.0
DROPOFF	Controller Dropoff Value	-5 to 105% of output	0
DEADBAND	Output Relay Deadband	<i>Time Duplex:</i> -5.0 to 25.0% <i>On/Off Duplex:</i> 0.0 to 25.0% <i>Position Prop. and 3P Step:</i> 0.5 to 5.0%	1.0
OUT HYST	Output Relay Hysteresis	0.0 to 100.0% of PV Span for On/Off control.	0.5
FAILMODE	Failsafe Mode	NO LAT LATCH	NO LAT
FAILSAFE	Failsafe Output Value for all outputs except 3P Step	Set within the range of the output limits. 0 to 100%	0.0
	Failsafe Output Value for 3P Step	0 PCT (motor goes to closed position) 100PCT (motor goes to open position)	--
SW FAIL	PDMR/ Position Proportional Motor Position when Slidewire Fails	0 PCT (motor goes to closed position) 100PCT (motor goes to open position)	--
MAN OUT	Power-up Preset Output for Manual Output	Within the range of output limits	--
AUTO OUT	Power-up Preset Output for Automatic Output	Within the range of output limits	--
PBorGAIN	Proportional Band or Gain Units	PB PCT GAIN	GAIN
MINorRPM	Reset Units	RPM MIN	MIN

3.11 Options Set Up Group

Table 3-10 Options Group Function Prompt

Function Prompt Lower Display	Function Name	Selections or Range of Setting Upper Display		Factory Setting
AUX OUT	Auxiliary Output One Loop Selection	DISABL INP 1 INP 2 PV DEV	OUTPUT SP LSP 1 CBOU IN AL1	DISABL
4mA VAL	Auxiliary Output Low Scaling Factor	Low scale value to represent 4 mA. Value in % for output, all others in engineering units.		0.0
20mA VAL	Auxiliary Output High Scaling Factor	High scale value to represent 20 mA. Value in % for output, all others in engineering units.		0
DIG IN 1	Digital Input 1 Selections	NONE TO MAN TO LSP TO 2SP TO 3SP TO DIR ToHOLD ToPID2 PV 2IN RERUN TO RUN ToBEGN STOP I	MAN FS ToLOCK ToAout TIMER AM STA ToTUNE SPinit TRACK1 TO RSP RST FB ToPURG LoFIRE MAN LT	NONE
DIG1 COM	Digital Input 1 Combinations	DISABL +PID2 +ToDIR	+ToSP2 +ToSP1 +RUN	DISABL
DIG IN 2	Digital 2 Input Selections	Same as DIG IN 1		NONE
DIG2 COM	Digital Input 2 Combinations	Same as DIG1 COM		DISABL

3.12 Communications Set Up Group

If your controller does not have this option, the prompts will not appear.

Table 3-11 Communications Group Function Prompts

Function Prompt Lower Display	Function Name	Selections or Range of Setting Upper Display		Factory Setting
ComSTATE	Communications Option State	DISABL MB3K	MODBUS RS422	DISABL
Com ADDR	Communications Station Address	1 to 99		0
SHEDENAB	Shed Enable	DISABL ENABL		DISABL
SHEDTIME	Shed Time	0 to 255 sample periods (1 sample period = 0.333 seconds) 0 = No Shed		0
PARITY	Parity	NONE ODD EVEN		ODD
		Fixed at NONE when ComSTATE = MODBUS		
BAUD	Baud Rate	2400 4800 9600 19200		2400
DUPLEX	Duplex Operation	HALF FULL		HALF

ATTENTION

- When ComSTATE = MODBUS, this selection is fixed at HALF.
- When the RS422/485/Auxiliary output option board is installed, this selection is fixed at HALF.

Function Prompt Lower Display	Function Name	Selections or Range of Setting Upper Display	Factory Setting
WS FLOAT	Word Swap Order	FP B Floating Point big endian FP BB Floating Point big endian with byte-swapped FP L Floating Point little endian FP LB Floating Point little endian with byte-swapped	
TX DELAY	Transmission Delay	1 to 500 milliseconds	1
SHEDMODE	Shed Controller Mode and Output Level	LAST TO MAN FSAFE ToAUTO	LAST
SHEDSP	Shed Setpoint Recall	TO LSP TO CSP	TO LSP
UNITS	Communication Units	PERCNT ENG	PERCNT
CSP RATO	Loop 1 Computer Setpoint Ratio	-20.0 to 20.0	1.0
CSP BIAS	Loop 1 Computer Setpoint Bias	-999. to 9999. (in engineering units)	0
LOOPBACK	Local Loop Back	DISABL ENABLE	DISABL

3.13 Alarms Set Up Group

Table 3-12 Alarms Group Function Prompts

Function Prompt Lower Display	Function Name	Selections or Range of Setting Upper Display	Factory Setting
A1S1 VAL	Alarm 1, Setpoint 1 Value	Value in Engineering Units	90
A1S2 VAL	Alarm 1, Setpoint 2 Value	Value in Engineering Units	10
A2S1 VAL	Alarm 2, Setpoint 1 Value	Value in Engineering Units	95
A2S2 VAL	Alarm 2, Setpoint 2 Value	Value in Engineering Units	5
A1S1TYPE	Alarm 1, Setpoint 1 Type	NONE INP 1 INP 2 PV (Process Variable) DEV (Deviation) OUTPUT SHED EV ON (Event On – SP Program) EV OFF (Event Off – SP Program) MANUAL REM SP (Remote Setpoint) F SAFE (Failsafe) PVRATE (PV Rate of Change) BREAK	NONE
A1S2TYPE	Alarm 1, Setpoint 2 Type	Same as A1S1TYPE	NONE
A2S1TYPE	Alarm 2, Setpoint 1 Type	Same as A1S1TYPE	NONE
A2S2TYPE	Alarm 2, Setpoint 2 Type	Same as A1S1TYPE	NONE
A1S1 H L	Alarm 1, Setpoint 1 State	LOW HIGH	HIGH
A1S1 EV	SP Programming Event Alarm State for Alarm 1, Setpoint 1	BEGIN END	--
A1S2 H L	Alarm 2, Setpoint 1 State	LOW HIGH	LOW

Function Prompt Lower Display	Function Name	Selections or Range of Setting Upper Display	Factory Setting
A1S2 EV	SP Programming Event Alarm State for Alarm 1, Setpoint 2	BEGIN END	--
A2S1 H L	Alarm 21, Setpoint 1 State	LOW HIGH	HIGH
A2S1 EV	SP Programming Event Alarm State for Alarm 2, Setpoint 1	BEGIN END	--
A2S2 H L	Alarm 2, Setpoint 2 State	LOW HIGH	LOW
A2S2 EV	SP Programming Event Alarm State for Alarm 2, Setpoint 2	BEGIN END	--
AL HYST	Alarm Hysteresis	0.0 to 100.0% of output or span, as appropriate	0.1
ALM OUT1*	Latching Alarm for Output 1	NO LAT LATCH	NO LAT
BLOCK	Alarm Blocking	DISABL BLOCK1 BLOCK2 BLK 12	DISABL

* For CE Conformity, Performance Criteria A, Select NO LAT

3.14 Display Parameters Set Up Group

Table 3-13 Display Group Function Prompts

Function Prompt Lower Display	Function Name	Selections or Range of Setting Upper Display	Factory Setting
DECIMAL	Control Loop 1 Decimal Place	XXXX XXX.X XX.XX X.XXX ATTENTION Auto-ranging will occur to whichever decimal place has been selected.	XXXX
TEMPUNIT	Control Loop 1 Temperature Units	DEG F DEG C NONE	NONE
PWR FREQ	Power Frequency	60 HZ 50 HZ	60 HZ
RATIO 2	Ratio for Input 2—Set from the front of the controller	DISABL ENABLE	DISABL
LANGUAGE	Display Language	ENGLIS FRENCH GERMAN SPANIS ITALAN	ENGLIS

3.15 Calibration Group

The prompts used here are for field calibration purposes. Refer to *Section 7 - Calibration* in manual #51-52-25-55 for complete information and instructions.

3.16 Status Group

The prompts used here are read only. They are used to determine the reason for a controller failure. Refer to *Section 9 – Troubleshooting* in manual #51-52-25-55 for complete information.

4. Operation

4.1 How to Power Up the Controller

When the power is applied, the controller will run three diagnostic tests. All the displays will light and then the controller will go into automatic mode after 20 seconds.

If one or more of these tests fail, the controller will go to the Fail-safe Manual Mode, and “FAILSAFE” will flash in the lower display.

If the output type is Position Proportional, and AUTO-CAL has never been done, a prompt “CAL MTR” will appear suggesting that the controller be calibrated. (See *Appendix D – Position Proportional Calibration.*)

Key Error

When a key is pressed and the prompt “KEY ERROR” appears in the lower display, it will be for one of the following reasons:

- parameter is not available,
- not in Set Up mode, press **SET UP** key first,
- key malfunction, do keyboard test.

4.2 Monitoring Your Controller

Operator Interface

The indicators and displays on the operator interface let you see what is happening to your process and how the controller is responding. Figure 1-1 is a view of the operator interface. A description of the displays and indicators is included.

Decimal Point Position

None, one or two decimal places are indicated on configuration. When a single decimal position has been configured and values greater than 1000 are displayed, the right-most character is blank, but the decimal point will be lit.

Viewing the Operating Parameters

Press the LOWER DISPLAY key to scroll through the operating parameters listed in Table 4-1. The lower display will show only those parameters and their values that apply to your specific model and the way in which it was configured.

Table 4-1 Lower Display Key Parameter Prompts

Indication	Description
OUT	OUTPUT #1—Output value is percent; for Three Position Step control, this is an estimated motor position when no slidewire exists.
SP	LOCAL SETPOINT #1—Also current setpoint when using SP Ramp.
2SP	LOCAL SETPOINT #2
3SP	LOCAL SETPOINT #3
RSP	REMOTE SETPOINT
1IN	INPUT 1—Used only with combinational input algorithms.
2IN	INPUT 2
POS	SLIDEWIRE POSITION—Used only with TPSC.
CSP	COMPUTER SETPOINT—When SP is in override.
DEV	DEVIATION—Maximum negative display is –999.9.
PIDSETX	TUNING PARAMETER SET 1—Selected set for single loop or primary loop configuration where X is either 1 or 2.
ET XX.XX	ELAPSED TIME—Time that has elapsed on timer in Hours.Minutes.
TR XX.XX	TIME REMAINING—Time that remains on timer in Hours.Minutes
RAMPXXXM	SETPOINT RAMP TIME—Time remaining in the setpoint ramp in minutes.
O SK XXXX	Soak # and TIME REMAINING IN SOAK
AUX	AUXILIARY OUTPUT
SPn	SP RATE SETPOINT—Current setpoint for setpoint rate applications
BIA	BIAS—Displays the manual reset value for algorithm PD+MR.
TUNE OFF	LIMIT CYCLE TUNING NOT RUNNING—Appears when Accutune is disabled.
TUNE RUN	LIMIT CYCLE TUNING RUNNING—Appears when Accutune is enabled.
ToBEGIN	RESET SP PROGRAM TO BEGINNING OF FIRST SEGMENT

Diagnostic Error Messages

The UDC 3300 performs background tests to verify data and memory integrity. If there is a malfunction, an error message will be displayed. In the case of more than one simultaneous malfunction, only the one with the highest priority will appear on the lower display. A list of error messages is contained in Table 4-2. If any of these error messages occur, refer to *Section 9 – Troubleshooting* in manual #51-52-25-55 for information to correct the failure.

Table 4-2 Error Messages

Prompt	Description
EE FAIL	Unable to write to nonvolatile memory.
INP1FAIL	Two consecutive failures of input 1 integration.
INP2FAIL	Two consecutive failures of input 2 integration.
SW FAIL	Slidewire input failure. Position proportional control automatically switched to TPSC.
CONF ERR	Configuration Errors—Low limit greater than high limit for PV, SP, Reset, or Output.
SOOTING	Input Combination Errors—Percent Carbon falls outside of “sooting boundary.”
IN1 RNG	Input 1 Out-of-Range
IN2 RNG	Input 2 Out-of-Range
PV RNG	PV Out-of-Range $PV = (PV \text{ source} \times PV \text{ source ratio}) + PV \text{ source bias}$
FAILSAFE	Failsafe Loop 1—Check inputs or configuration.
RV LIMIT	Remote Variable Out-of-Range $RV = (RV \text{ source} \times RV \text{ source ratio}) + RV \text{ source bias}$
SEG ERR	Segment Error—SP Program starting segment number is less than ending segment number.
CAL MTR	Not calibrated. Perform Position Proportional calibration.

4.3 Start-up Procedure

Table 4-3 Procedure for Starting Up the Controller

Step	Operation	Press	Action
1	Select manual mode	<u>MANUAL</u> AUTO	until "MAN" indicator is ON. The controller is in manual mode.
2	Adjust the output	▲ or ▼	to adjust the output value and ensure that the final control element is functioning correctly. <i>Upper Display:</i> PV value <i>Lower Display:</i> OUT and the output value in %
3	Enter the local setpoint	LOWER DISPLAY ▲ or ▼	<i>Upper Display:</i> PV Value <i>Lower Display:</i> SP and the local setpoint value to adjust the local setpoint to the value at which you want the process variable maintained. The local setpoint cannot be changed if the Setpoint Ramp function is running. "R" appears in the upper display.
4	Select automatic mode	<u>MANUAL</u> AUTO	until "A" indicator is ON. The controller is in Automatic mode. The controller will automatically adjust the output to maintain the process variable at setpoint, if the controller is properly tuned.
5	Tune the controller	SET UP	Tuning will be required on the first startup. First enable "TUNE" selection in the Accutune Group. Refer to Tuning Set Up group to ensure that the proper selections for PROP BD or GAIN, RATE MIN, and RSET MIN, or RSET RPM have been entered. Use Accutune to tune the controller as follows: <ol style="list-style-type: none"> 1. Adjust setpoint to the desired value. 2. Switch to Automatic mode by pressing the MANUAL/AUTO key. 3. Initiate Tuning by: <ul style="list-style-type: none"> • Pressing the up arrow key when the lower display prompt shows TUNE-OFF, or • Pressing the LOWER DISPLAY and Up arrow keys simultaneously, or... • Using the Digital Input, if configured. If it is necessary to stop or abort the tuning process, press the MANUAL/AUTO key and the controller will return to manual mode.

4.4 Operating Modes

The controller can operate in any of three basic modes:

- Manual
- Automatic with Local Setpoint
- Automatic with Remote Setpoint

4.5 Setpoints

You can configure the following setpoints for the UDC 3300 controller in the control group.

- A single local setpoint (SP)
- Two local setpoints (SP, 2SP)
- One local setpoint and one remote setpoint (SP, RSP)
- Three local setpoints (SP, 2SP, 3SP)
- Two local setpoints and one remote setpoint (SP, 2SP, RSP)

Changing Local Setpoint 1, 2 or 3

To scroll through the setpoint type menu, press and hold in the SETPOINT SELECT key. Release when the desired active setpoint selection is displayed.

ATTENTION

“KEY ERROR” will appear in the lower display if:

- You choose either local setpoint 2 or 3 or remote setpoint and your choice has not been configured as the setpoint source.
 - You attempt to change the setpoint while a Setpoint Ramp is enabled.
 - Setpoint Ramp rate will apply to Local SP changes, if enabled.
-

After changing a local setpoint value, if no other key is pressed, a minimum of 30 seconds time will elapse before the new value is stored in nonvolatile memory. If power is removed before this time, the new setpoint value is lost and the previous setpoint value is used at power up. If another key is pressed after changing the LSP value, then the value is stored immediately.

Setpoint Selection Indication

Table 4-4 Setpoint Selection Indication

	Using Local Setpoint	Using Remote Setpoint	Using 2nd Local Setpoint	Using 3rd Local Setpoint
	SP	RSP	2SP	3SP
Upper Display	PV and the PV value	PV and the PV value	PV and the PV value	PV and the PV value
Lower Display	SP and the Local Setpoint Value	RSP and Remote Setpoint Value	2SP and the 2nd Local Setpoint Value	3SP and the 3rd Local Setpoint Value
Annunciator	None	“■” lights	“■” lights	“3” lights

4.6 Using Two Sets of Tuning Constants

Select Two Sets or Gain Scheduling

Table 4-5 Procedure for Selecting Two Sets of Tuning Constants

Step	Operation	Press	Action
1	Select Control Set Up group	SET UP	until you see SET UP in Upper Display and CONTROL in Lower Display.
2	Select PID SETS function	FUNCTION LOOP 1/2 ▲ or ▼	until you see the function desired in the Upper Display and PID SETS in the Lower Display. to select the type of PID SET.

Set Switchover Value

If you select 2PV SW or 2SP SW, you must set a value at which the sets will switch over. The procedure in Table 4-6 shows you how to set this value. ***This procedure assumes that you are still in the Control Set Up group from Table 4-5.***

Table 4-6 Procedure for Setting Switchover Values

Step	Operation	Press	Action
1	Select Switchover value function	FUNCTION LOOP 1/2 ▲ or ▼	until you see the switchover value in the Upper Display and SW VALUE in the Lower Display. to select the switchover value in the upper display.

Set Tuning Constant Values for Each Set

There are specific tuning constants that must be set for each set. The procedure below shows you how to access these constants and change their value.

Table 4-7 Procedure for Setting Tuning Constant Values

Step	Operation	Press	Action
1	Select Tuning Set Up Group	SET UP	until you see TUNING in the Lower Display
2	Select the tuning constants	FUNCTION LOOP 1/2	to successively display the available constants in the Lower Display. The value is displayed in the Upper Display.
		▲ or ▼	To change the value of any of the above listed prompts in the lower display.

Switch Between Two Sets via the Keyboard (Without Automatic Switchover)

This procedure is operational only if 2 PID SETS was configured at the Control Set Up group.

Table 4-8 Procedure for Switching PID SETS from the Keyboard

Step	Operation	Press	Action
1	Access the PID set display	LOWER DISPLAY	until you see the PV value displayed in the Upper Display and the PIDSETx in the Lower Display.
		▲ or ▼	to change PIDSET1 to PIDSET2 or vice versa. You can use Accutune on each set.

4.7 Alarm Setpoints

Procedure for Displaying the Alarm Setpoints

Table 4-9 Procedure for Displaying or Changing the Alarm Setpoints

Step	Operation	Press	Action
1	Access the Alarm Set Up group	SET UP	until you see ALARMS in the Lower Display.
2	Access the Alarm Setpoint Values	FUNCTION LOOP 1/2 ▲ or ▼	to successively display the alarm setpoints and their values. to change any alarm setpoint value you select in the upper display.
3	Return to normal operation	LOWER DISPLAY	

4.8 Three Position Step Control Algorithm

The Three Position Step Control algorithm (Loop 1 only) allows the control of a valve (or other actuator) with an electric motor driven by two controller output relays; one to move the motor upscale, the other to move it downscale, without a feedback slidewire linked to the motor shaft. Accutune **TUNE** operates with this algorithm.

Displaying the Motor Position

Table 4-10 Procedure for Displaying the 3PSTEP Motor Position

Step	Operation	Press	Action
1	Access the displays	LOWER DISPLAY	until you see the PV Value in the Upper Display and either POS or OUT in the Lower Display.

4.9 Input Math Algorithms

If selected via Math options, this controller has one input algorithm available. The algorithm can be configured to provide a derived (calculated) PV or a derived remote setpoint. Up to three inputs may be applied to the calculation.

Standard functionality:

- Basic models (DC330B) contain as standard: Weighted Average, Feedforward Summer, Feedforward Multiplier.

Input Algorithm Selections

Algorithm selections are made in *Section 3 – Configuration*. The following function prompt can be found in the Algorithm Set Up group:

IN ALG1

This selection includes the following algorithms:

Weighted Average
Feedforward Summer
Feedforward Multiplier
Carbon Potential (several types)
Dewpoint

Input A, Input B, and Input C selections for these formulas are found in *Section 3 – Configuration*; Set Up group ALGORITHM, under the following function prompts:

ALG1 INA
ALG1 INB
ALG1 INC

4.10 Digital Input Option (Remote Switching)

The Digital Input option detects the state of external contacts for either of two inputs. On contact closure, the controller will respond according to how each digital input is configured. Make your selection under the Option Set Up group function prompt “DIG IN1” or “DIG IN2.” See *Section 3 – Configuration* in manual #51-52-25-55.

Table 4-11 Digital Input Option Action on Contact Closure

DIG IN1 or DIG IN2 Selections	Display Indication	Action on Contact Closure Returns (toggles) to original state when contact opens, unless otherwise noted.
None	DI 1 2 always off*	No Digital Input selection
TO MAN	MAN blinks	Puts the controller into manual mode.
TO LSP		Puts the controller into local setpoint 1.
TO 2SP	RSP annunciator blinks	Puts the controller into local setpoint 2.
TO 3SP	RSP annunciator blinks	Puts the controller into local setpoint 3.
TO DIR		Selects direct controller action.
ToHOLD	H blinks	Suspends setpoint program or setpoint ramp operation.
ToPID2	PIDSET2 in lower display	Selects PID set 2.
PV 2IN	II (II blinks) IN	Selects the PV to equal Input 2.
RERUN		Resets the Setpoint Program back to the beginning of the first segment in the program and leaves the program in the same Run Or Hold mode that it was in when the DI closed. Opening the DI has no further effect.
TO RUN	R indicator blinks	Starts a stopped SP Program.
ToBEGN		Resets the Setpoint Program back to the beginning of the first segment in the program and places the program into the Hold mode.
STOP I		Disables PID Integral (I) action.
MAN FS	MAN blinks	Unit goes to manual mode, output goes to the failsafe value.
ToLOCK	LOCKED when a key is pressed	Disables all keys.
ToAout		Output is forced to value set at control prompt “AUTO OUT” when controller is in automatic mode.

DIG IN1 or DIG IN2 Selections	Display Indication	Action on Contact Closure Returns (toggles) to original state when contact opens, unless otherwise noted.
TIMER	Timer clock () and time appear in lower display.	Starts timer (momentary). Reopening switch has no effect.
AM STA		Causes switch to Auto Manual Station mode.
ToTUNE	TUNE ON in lower display	Starts the Accutune process.
SPinit		Forces the SP to initialize at the current PV value.
TRACK1	O blinks	Allows Output 1 to track Input 2.
TO RSP	RSP annunciator blinks	Selects remote setpoint, if enabled.
RST FB		Allows Input 2 to override the internal reset value, providing external reset feedback.
ToPURG	MAN blinks and output value shows in lower display	Forces loop to manual mode with the output values set to the Output High Limit configuration.
LoFIRE	MAN blinks and output value shows in lower display	Forces loop to manual mode with the output set to the Output Low Limit configuration.
MAN LT		Forces loop to manual mode, latched. Opening DI has no effect on Mode. UDC remains in manual mode.

Keyboard Operation

Front panel keys have no effect on the digital input action in the closed state.

Digital Inputs 1 and 2 Combination Selections

Table 4-12 Digital Input Combinations “DIG IN1” or “DIG IN2”

Selections used in Combination with “DIG IN1” or “DIG IN2”	Display Indication	Action on contact closure Returns (toggles) to original state when contact opens.
+PID2	PIDSET 2 in lower display	Selects PID set 2.
+ToDIR		Puts the controller into direct action.
+ToSP2	RSP blinks	Selects the second local setpoint.
+ToSP1		Selects the local setpoint.
+RUN	R indicator blinks	Starts or restarts RUN of SP RMP/PROG.

4.11 Fuzzy Overshoot Suppression

Fuzzy Overshoot Suppression minimizes overshoot after a setpoint change or a process disturbance. This is especially useful in processes that experience load changes or where even a small overshoot beyond the setpoint may result in damage or lost product.

Configuration

To configure this item, refer to *Section 3 – Configuration*:

- Set Up Group **ACCUTUNE**
- Function Prompt **FUZZY**
- Select **ENABLE** or **DISABL** (▲ or ▼)

4.12 Accutune

Demand Tuning is available for the UDC3300 Basic Models.

- **(TUNE) Demand Tuning**—Tuning is done on demand
 - by pressing the LOWER DISPLAY and ▲ keys simultaneously,
 - by selecting prompt “TUNE” in the lower display,
 - via digital input.

Configuration

To configure this item, refer to *Section 3 – Configuration*.

Rules and Regulations

- **TUNE** On Demand tuning will work for all control algorithms except ON/OFF. Process line out is not required.
- **TUNE** On Demand tuning works for integrating processes.
- Tuning is done in automatic mode.
- Tuning can be monitored or reconfigured using communications option.
- Tuning can be enabled via digital inputs.
- Tuning can be aborted by going to manual mode or disabling via configuration.
- When tuning is in progress, a large **T** appears in the upper display and disappears as soon as tuning is completed.
- Setpoint changes can be made during operation. The setpoint at the time tuning starts is captured and Tune runs until completion, then proceeds to the new SP value following the completion of tuning.

Starting TUNE (Demand Tuning)

After TUNE has been enabled use the following procedure to start tuning.

Table 4-13 Procedure for Starting TUNE (Demand) Tuning

Step	Action
1	Set the setpoint to the desired value.
2	Switch to Automatic mode by pressing the Manual/Auto key.
3	Initiate Tuning by: <ul style="list-style-type: none"> • pressing the ▲ key when the lower display prompt = TUNE-OFF, • pressing the Lower Display and ▲ keys simultaneously, or • using the digital input, if configured.

Aborting Tuning

If it is necessary to stop or abort the tuning process, press the MANUAL/AUTO key and the controller will return to manual mode. You can also disable TUNE in the ACCUTUNE Set Up group.

Tune for Duplex (Heat/Cool)

TUNE can be done for applications using duplex (heat/cool) control. During tuning, Accutune requires that **setpoint 1** will cause a Heating demand, and then the calculated tuning parameters will be automatically entered as PID set 1. Likewise, it requires that tuning at local **setpoint 2** will cause a Cooling demand, and then the cooling parameters will be entered as PID set 2.

The tuning sequence will cycle the controller's output two full cycles between the high output limit and 50% for HEAT or between 50% and the low output limit for COOL while allowing only a small process variable change above and below the setpoint during each cycle.

Configuring TUNE for Duplex (Heat/Cool)

To configure this item, refer to *Section 3 – Configuration*.

Using TUNE at Start-Up for Duplex (Heat/Cool)

Table 4-14 Procedure for Using TUNE at Start-up for Duplex

Step	Action
1	<p>Heat Zone:</p> <ul style="list-style-type: none"> • Adjust Local Setpoint 1 to a value within the Heat zone. • Put the controller in <i>Automatic</i> mode. • Press the Lower Display and ▲ keys simultaneously to initiate Heat tuning. <p>The output will cycle between 50% and 100% (or high output limit). A large T appears in the upper display until tuning is completed and final Heat parameters are entered for PID set 1 in the Tuning group.</p>
2	<p>Cool Zone:</p> <ul style="list-style-type: none"> • Adjust Local Setpoint 2 to a value within the Cool zone. • Put the controller in <i>Automatic</i> mode. • Press the Lower Display and ▲ keys simultaneously to initiate Cool tuning. <p>The output will cycle between 0 % and 50 % (or low output limit). A large T appears in the upper display until tuning is completed and final Cool parameters are entered for PID set 2 in the Tuning group.</p>

4.13 Entering a Security Code

The level of keyboard lockout may be changed in the Set Up mode. However, knowledge of a security code number (0 to 4095) may be required to change from one level of lockout to another. When a controller leaves the factory, it has a security code of 0, which permits changing from one lockout level to another without entering any other code number.

If you require the use of a security code, select a number from 0001 to 4095 and enter it when the lockout level is configured as NONE. Thereafter, that selected number must be used to change the lockout level from something other than NONE.

CAUTION Write the number on the Configuration Record Sheet in Appendix C so you will have a permanent record.

Table 4-15 Procedure to Enter a Security Code

Step	Operation	Press	Result
1	Enter Set Up Mode	SET UP	<i>Upper Display = SET UP</i> <i>Lower Display = TUNING</i>
2	Select any Set Up Group	FUNCTION LOOP 1/2	<i>Upper Display = 0</i> <i>Lower Display = SECUR</i>
3	Security Code Entry	▲ or ▼	To enter a four digit number in the upper display (0001 to 4095) This will be your security code.

5. Setpoint Rate/Ramp/Soak Program Operation

5.1 Setpoint Ramp Rate

Introduction

When you have configured a Setpoint Ramp Rate, it will apply immediately to any local setpoint change.

Configuration Check

Make sure you:

- enable SP RATE
- disable SP RAMP and SP PROG
- set an upscale or downscale rate value

ATTENTION

A value of 0 will imply an immediate change in setpoint; that is, NO RATE applies. See *Section 3.4* for details.

Operation

When a local setpoint change is made, the controller will ramp from the original setpoint to the new one at the rate specified. This changing (current) setpoint can be viewed as SPn on the lower display.

Press the LOWER DISPLAY key until you see SPn and the setpoint value in the lower display.

5.2 Single Setpoint Ramp

Introduction

When you have configured a single setpoint ramp, it will occur between the current local setpoint and a final local setpoint over a time interval of from 1 to 255 minutes. You can RUN or HOLD the ramp at any time.

Configuration Check

Make sure you:

- enable SP RAMP
- disable SP RATE and SP PROG
- set the ramp time in minutes
- set the final setpoint value

See *Section 3.4* for details.

Operation

Running a Setpoint Ramp includes enabling, starting, holding, viewing the ramp time, and ending the ramp.

Table 5-1 Procedure for Running a Setpoint Ramp

Step	Operation	Press	Action
1	Enable the Setpoint Ramp function	SET UP	until you see SET UP in the Upper Display and SP RAMP in the Lower Display.
		<u>FUNCTION LOOP 1/2</u>	You will see DISABL or ENABLE in the Upper Display and SP RAMP in the Lower Display
		▲	until you see ENABLE in the Upper Display.
2	Put the controller into Automatic mode	<u>MANUAL AUTO</u>	until “A” indicator is ON and you will see: H and the PV value in the Upper Display. SP and the present setpoint value in the Lower Display.
3	Set Start Setpoint	▲ or ▼	until the start setpoint value you desire is indicated in the lower display:
4	Start the Ramp	<u>RUN HOLD</u>	You will see R and the PV value in the Upper Display and SP and the changing setpoint value in the Lower Display.
5	Hold/Run the Ramp	<u>RUN HOLD</u>	This holds the ramp at the current setpoint value. (SP can then be changed by the ▲ and ▼ keys.) Press again to continue run.
			ATTENTION Any time the local setpoint is different from the final setpoint value and the RUN/HOLD key is pressed, the ramp will start again.
6	View the remaining ramp time	<u>LOWER DISPLAY</u>	until you see: R or H and the PV value in the Upper Display. RAMP time remaining in the Lower Display.
7	End the Ramp		When the final setpoint is reached, the “R” changes to “H” in the upper display and the controller operates at the new setpoint.
8	Return to normal operating mode		After the SP Ramp has completed, disable the SP RAMP function, then press the LOWER DISPLAY key.

5.3 Setpoint Ramp/Soak Programming Option

Introduction

Setpoint Ramp/Soak Programming lets you configure six ramp and six soak segments to be stored for use as one program or several small programs. You designate the beginning and end segments to determine where the program is to start and stop.

Review Program Data and Configuration

The procedure for programming is straightforward and aided by prompts. We suggest that you read Table 5-2 which lists the program contents with an explanation of each to aid in configuration. Then refer to *Section 3.4 – SP Ramp, SP Rate, or SP Programming Set Up Group* to enable and configure the setpoint program.

ATTENTION

SP RATE and SP RAMP must be disabled to enable SP PROG (Setpoint Programming).

Fill Out the Worksheet

Referring to the example in Figure 5-1, draw a Ramp/Soak Profile on the worksheet provided in Figure 5-2 and fill in the information for each segment. This will give you a record of how the program was developed.

Operation

See Table 5-3 to run/monitor the program.

Power Outage

ATTENTION

If power is lost during a program, upon power-up the controller will be in hold and the setpoint value will be the setpoint value prior to the beginning of the setpoint program. The program is placed in hold at the beginning of the first segment in the program. The mode will be as configured under PWR MODE in the Control function group.

Table 5-2 Program Contents

Contents	Definition
Ramp Segments	<p>A ramp segment is the time it will take to change the setpoint to the next setpoint value in the program.</p> <ul style="list-style-type: none"> • Ramps are odd number segments. • Ramps are configured in either Time or Engineering Units per Minute or Engineering Units per Hour (see Ramp Unit below.) <p>NOTE: Entering "0" will imply an immediate step change in setpoint to the next soak.</p>
Ramp Unit	<p>The Ramp Unit selection determines the engineering data units for the ramp segments. The selections are:</p> <ul style="list-style-type: none"> • TIME = Hours:Minute (XX:XX) (<i>Range:</i> 0-99 hrs:0-59 min.) • EU/MIN = Degrees/Minute or EU/HR = Degrees/Hour (<i>Range:</i> 0 to 999)
Soak Segments	<p>A Soak Segment is a combination of soak setpoint (value) and a soak duration (time).</p> <ul style="list-style-type: none"> • Soaks are even number segments. • The soak setpoint range value must be within the setpoint high and low range limits in engineering units. • Soak time is the duration of the soak and is determined in: TIME – Hours.Minutes <i>Range:</i> 0-99hrs.59min.
Start Segment	<p>This designates the number of the first segment (Odd number). <i>Range:</i> 1 to 11</p>
End Segment	<p>This designates the number of the last Soak segment (Even Number). <i>Range:</i> 2 to 12</p>
Recycle Number	<p>This number allows the program to recycle to a specified number of times from beginning to end. <i>Range:</i> 0 to 99</p>
Guaranteed Soak	<p>Each soak segment can have a deviation value of from 0 to ± 99 which guarantees the value for that segment. The value is the number in engineering units, above or below the setpoint, out side of which the timer halts. <i>Range:</i> 0 to ± 99</p> <p>Soak deviation values >0 guarantee that the soak segment's process variable is within the \pm deviation for the configured soak time. Whenever the \pm deviation is exceeded, soak timing is frozen.</p> <p>The guaranteed soaks feature is disabled whenever the deviation value is configured to 0.</p>
Program State	<p>This selection determines whether the program is in the Hold state or Disabled after completion of the program.</p>
Program Termination State	<p>This function determines the status of the controller upon completion. The selections are:</p> <ul style="list-style-type: none"> • LASTSP = controls to last setpoint and last control mode • F SAFE = manual mode, failsafe output

Contents	Definition
Hot Start	This function determines whether LSP1 or PV is used as the setpoint when the program is initially changed from HOLD to RUN. The selections are: <ul style="list-style-type: none">• DISABL = present LSP1 is default setpoint• ENABL = present PV value is used as beginning setpoint value for the ramp segment
Reset Program to Beginning	When enabled, this selection allows you to reset the program to the beginning or rerun it from the keyboard.

Setpoint Rate/Ramp/Soak Program Operation

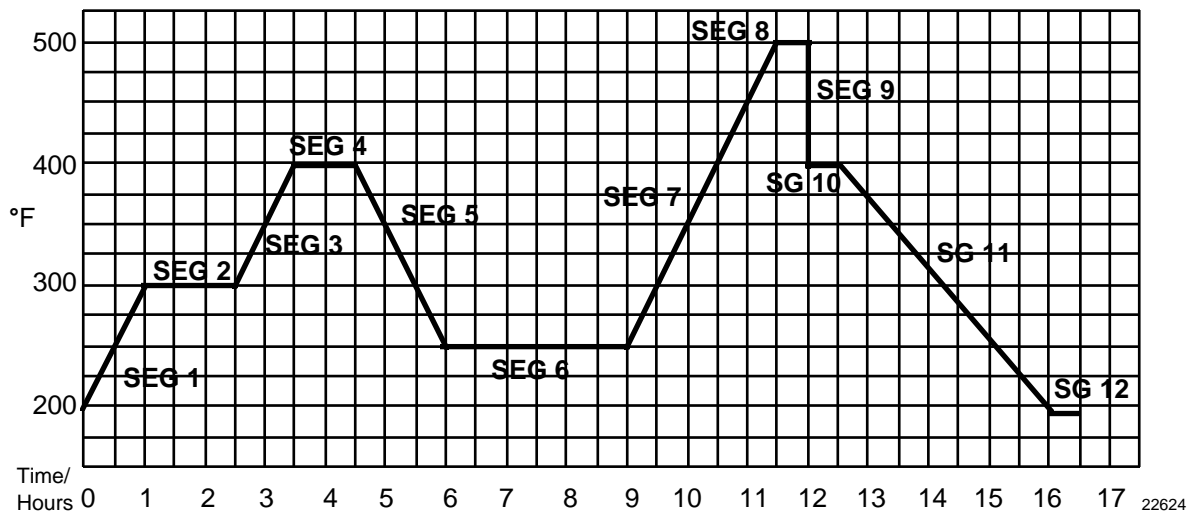
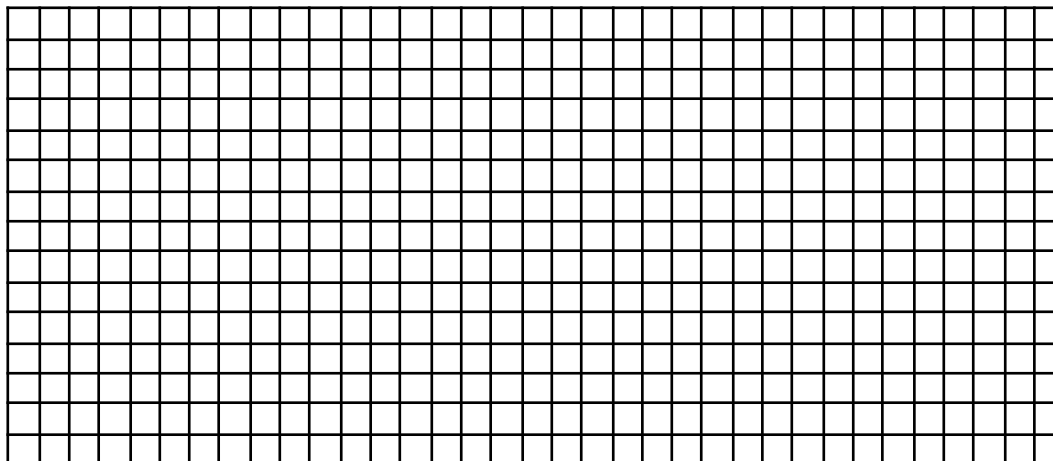

Figure 5-1 Ramp/Soak Profile Example

Prompt	Function	Segment	Value	Prompt	Function	Segment	Value
STRT SEG	Start Seg.		1	SEG4TIME	Soak Time	4	1 hr.
END SEG	End Seg.		12	SEG5RAMP	Ramp Time	5	1hr.:30min.
RAMP UNIT	Engr. Unit for Ramp		TIME	SEG6 SP	Soak SP	6	250
RECYCLES	Number of Recycles		2	SEG6TIME	Soak Time	6	3hr.:0min.
SOAK DEV	Deviation Value		0	SEG7RAMP	Ramp Time	7	2hr.:30min.
PROG END	Controller Status		LAST SP	SEG8 SP	Soak SP	8	500
STATE	Controller State at end		HOLD	SEG8TIME	Soak Time	8	0hr.:30min.
KEYRESET	Reset SP Program		DISABL	SEG9RAMP	Ramp Time	9	0
HOTSTART	PV Hot Start Program Initialization or power up in SPP		DISABL	SG10 SP	Soak SP	10	400
SEG1RAMP	Ramp Time	1	1 hr.	SG10 TIME	Soak Time	10	0hr.:30min.
SEG2 SP	Soak SP	2	300	SG11RAMP	Ramp Time	11	3hr.:30min.
SEG2TIME	Soak Time	2	1hr.:30min.	SG12 SP	Soak SP	12	200
SEG3RAMP	Ramp Time	3	1hr.	SG12TIME	Soak Time	12	0hr.:30min.
SEG4 SP	Soak SP	4	400				

Program Record Sheet

Draw your ramp/soak profile on the record sheet shown in Figure 5-2 and fill in the associated information in the blocks provided. This will give you a permanent record your program and will assist you when entering the setpoint data.



22625

Figure 5-2 Program Record Sheet

Prompt	Function	Segment	Value
STRT SEG	Start Seg.		
END SEG	End Seg.		
RAMPUNIT	Engr. Unit for Ramp		
RECYCLES	Number of Recycles		
SOAK DEV	Deviation Value		
PROG END	Controller Status		
STATE	Controller State at end		
KEYRESET	Reset SP Program		
HOTSTART	PV Hot Start Program Initialization or power up in SPP		DISABL
SEG1RAMP	Ramp Time	1	
SEG2 SP	Soak SP	2	
SEG2TIME	Soak Time	2	
SEG3RAMP	Ramp Time	3	
SEG4 SP	Soak SP	4	
SEG4TIME	Soak Time	4	
SEG5RAMP	Ramp Time	5	
SEG6 SP	Soak SP	6	
SEG6TIME	Soak Time	6	
SEG7RAMP	Ramp Time	7	
SEG8 SP	Soak SP	8	
SEG8TIME	Soak Time	8	
SEG9RAMP	Ramp Time	9	
SG10 SP	Soak SP	10	
SG10 TIME	Soak Time	10	
SG11RAMP	Ramp Time	11	
SG12 SP	Soak SP	12	
SG12TIME	Soak Time	12	

Run/Monitor Functions

Table 5-3 lists all the functions required to run and monitor the program.

Table 5-3 Run/Monitor Functions

Function	Press	Result
Set the Local Setpoint	SETPOINT SELECT	<i>Lower Display: SP</i>
	▲ or ▼	to set the Local Setpoint value to where you want the program to start out.
Run State	<u>RUN</u> HOLD	Initiates the setpoint program. An "R" appears in the upper display indicating that the program is running.
Hold State	<u>RUN</u> HOLD	Holds the setpoint program. An "H" appears in the upper display indicating that the program is in the HOLD state. The setpoint holds at the current setpoint.
External Hold DI = To HOLD"		If Remote Switching (Digital Input option) is present on your controller, contact closure places the controller in the HOLD state, if the setpoint program is running. The "H" in the upper display will blink indicating external hold is in effect. Contact reopening runs program. NOTE: The keyboard takes priority over external switch for the RUN/HOLD function.
Changing a Segment While in Hold	▲ or ▼	These keys will operate and allow you to change the segment number while in HOLD. If a different segment is selected, it will be started at the beginning when placed in RUN. If the original segment is brought back, the program will continue from the point placed in HOLD. NOTE: Changing a segment number may affect the alarms/events.
External Program Reset "To BEGN"		If Remote Switching (Digital Input option) is present on your controller, contact closure resets the SP Program back to the start of the first segment. Program cycle number is not affected. Reopening the contact has no effect and places the program in HOLD mode. The setpoint is changed to what the setpoint was when the program was first started.
	<u>RUN</u> HOLD	restarts the Setpoint Program.

Function	Press	Result
Keyboard Reset	LOWER DISPLAY	<p>until you see <i>Lower Display:</i> ToBEGN</p> <p>Press ▲ key to reset program to beginning at Hold state.</p>
Viewing the Present Ramp or Soak Segment Number and Time	LOWER DISPLAY	<p>until you see <i>Upper Display:</i> "R" and the PV value <i>Lower Display:</i> Ramp segments: # RA XX.XX Soak segments: # SK XX.XX</p> <p># indicates the segment number (Ramp–odd only, Soak–even only)</p> <p>XX.XX Ramp Time – Hours.Minutes Ramp Rate – EU/MIN or EU/HR Soak Time – Hours.Minutes</p>
Viewing the Number of Cycles Left in the Program	LOWER DISPLAY	<p>until you see <i>Upper Display:</i> "R" and the PV value <i>Lower Display:</i> RECYC XX</p> <p>Number of cycles remaining in the setpoint program. XX = 0 to 99</p>
End Program		<p>When the final segment is completed, the "R" in the upper display either changes to "H" (if configured for HOLD state) or disappears (if configured for disable of setpoint programming).</p> <p>The controller operates at the last setpoint in the program in automatic or will be in manual mode at the failsafe output.</p>
Disable Program		See <i>Section 3.4</i> for details.

6. Appendix A – Environmental and Operating Conditions

Parameter	Reference	Rated	Operative Limits	Transportation and Storage
Ambient Temperature	25 °C ± 3 °C 77 °F ± 5 °F	15 °C to 55 °C 58 °F to 131 °F	0 °C to 55 °C 32 °F to 131 °F	–40 °C to 66 °C –40 °F to 151 °F
Relative Humidity	10 to 55*	10 to 90*	5 to 90*	5 to 95*
Vibration				
Frequency (Hz)	0	0 to 70	0 to 200	0 to 200
Acceleration (g)	0	0.4	0.6	0.5
Mechanical Shock				
Acceleration (g)	0	1	5	20
Duration (ms)	0	30	30	30
Voltage (Vdc)	+24 ± 1	20 to 27	20 to 27	--
Voltage (Vac)				
90 to 240 Vac	120 ± 1 240 ± 2	90 to 240	90 to 264	-- --
24 Vac	24 ± 1	20 to 27	20 to 27	--
Frequency (Hz)	50 ± 0.2	49 to 51	48 to 52	--
(For Vac)	60 ± 0.2	59 to 61	58 to 62	--
Power Consumption	18 VA maximum (90 to 264 Vac) 12 VA maximum (24 Vac/dc)			
Input Accuracy	± 0.20 % of span typical (± 1 digit for display) Field calibratable to ± 0.05 % of span typical 15-bit resolution typical			
CE Conformity Special Conditions (Europe)	Shielded twisted pair cables are required for all analog I/O, process variable, RTD, thermocouple, dc millivolt, low level signal, 4-20 mA, digital I/O, and computer interface circuits.			

Refer to 51-52-05-01, How to Apply Digital Instrumentation in Severe Electrical Noise Environments, for additional information.

* The maximum rating only applies up to 40 °C (104 °F). For higher temperatures, the RH specification is derated to maintain constant moisture content.

7. Appendix B – Model Selection Guide

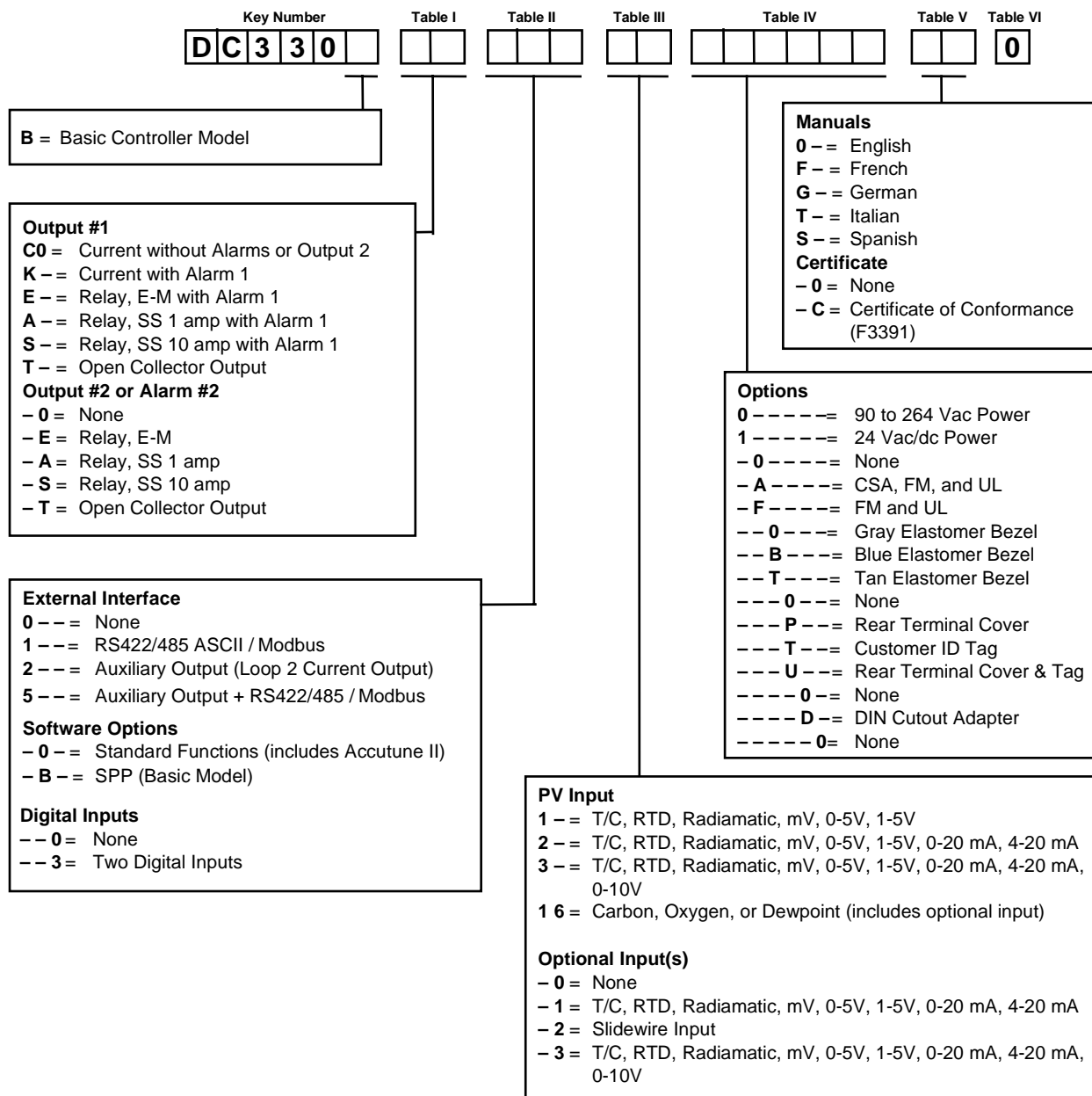

8. Appendix C – Configuration Record Sheet

Enter the value or selection for each prompt on this sheet so you will have a record of how your controller was configured.

Group Prompt	Function Prompt	Value or Selection	Factory Setting	Group Prompt	Function Prompt	Value or Selection	Factory Setting	
TUNING	PROP BD	_____	—	ALGORITHM	CONT ALG	_____	PID A	
	or GAIN	_____	1.000		TIMER	_____	DISABL	
	or GAINVALn	Read Only	—		PERIOD	_____	0.01	
	RATE MIN	_____	0.00		START	_____	KEY	
	RSET MIN	_____	1.00		L DISP	_____	TI REM	
	or RSET RPM	_____	—		INP ALG1	_____	NONE	
	MAN RSET	_____	0		MATH K	_____	—	
	PROPBD2	_____	—		CALC HI	_____	—	
	or GAIN 2	_____	1.000		CALC LO	_____	—	
	RATE2MIN	_____	0.00		ALG1 INA	_____	—	
	RSET2MIN	_____	1.00		ALG1 INB	_____	—	
	or RSET2RPM	_____	—		ALG1 INC	_____	—	
	CYC SEC	_____	20		ALG1BIAS	_____	—	
	or CYC SX3	_____	20		PCT CO	_____	0.200	
	CYC2 SEC	_____	20					
	or CYC2 SX3	_____	20		OUT ALG	OUT ALG	_____	CURRNT
	SECURITY	_____	0		4-20 RNG	_____	100PCT	
	LOCKOUT	_____	CALIB		RLYSTATE	_____	1OF2ON	
	AUTO MAN	_____	ENABLE		RLY TYPE	_____	MECHAN	
	SP SEL	_____	ENABLE					
RUN HOLD	_____	ENABLE						
SP RAMP	SP RAMP	_____	DISABL	INPUT 1	IN1 TYPE	_____	0-10mV	
	TIME MIN	_____	3		XMITTER1	_____	LINEAR	
	FINAL SP	_____	1000		IN1 HI	_____	1000	
	PV HOT	_____	DISABL		IN1 LO	_____	0	
	START	_____	—		RATIO 1	_____	1.00	
	SP RATE	_____	DISABL		BIAS IN1	_____	0	
	EU/HR UP	_____	0		FILTER 1	_____	0	
	EU/HR DN	_____	0		BURNOUT1	_____	NONE	
SP PROG	_____	DISABL	EMISSIV1	_____	0.00			
ACCUTUNE	FUZZY	_____	DISABL	INPUT 2	IN2 TYPE	_____	0-10mV	
	ACCUTUNE	_____	DISABL		XMITTER2	_____	LINEAR	
	AT ERROR	Read Only	—		IN2 HI	_____	1000	
					IN2 LO	_____	0	
					RATIO 2	_____	1.00	
					BIAS IN2	_____	0	
					FILTER 2	_____	0	
					BURNOUT2	_____	NONE	
			EMISSIV2	_____	0.00			

Configuration Record Sheet

Group Prompt	Function Prompt	Value or Selection	Factory Setting	Group Prompt	Function Prompt	Value or Selection	Factory Setting	
CONTROL	PV SOURC	_____	INP 1	COM	ComSTATE	_____	DISABL	
	PID SETS	_____	1 ONLY		Com ADDR	_____	0	
	SW VALUE	_____	0.00		SHEDENAB	_____	DISABL	
	LSP'S	_____	1 ONLY		SHEDTIME	_____	0	
	RSP SRC	_____	NONE		PARITY	_____	ODD	
	AUTOBIAS	_____	DISABL		BAUD	_____	2400	
	SP TRACK	_____	NONE		DUPLEX	_____	HALF	
	PWR MODE	_____	MANUAL		WS FLOAT	_____	PF b	
	PWR OUT	_____	LAST		TX DELAY	_____	1	
	SP HiLIM	_____	1000		SHEDMODE	_____	LAST	
	SP LoLIM	_____	0		SHED SP	_____	TO LSP	
	ACTION	_____	REVRSE		UNITS	_____	PERCNT	
	OUT RATE	_____	DISABL		CSP RATO	_____	1.0	
	PCT/M UP	_____	0		CSP BIAS	_____	0	
	PCT/M DN	_____	0		LOOPBACK	_____	DISABL	
	OUTHILIM	_____	100					
	OUTLoLIM	_____	0					
	I Hi LIM	_____	100.0		ALARMS	A1S1 VAL	_____	90
	I Lo LIM	_____	0.0			A1S2 VAL	_____	10
	DROPOFF	_____	0			A2S1 VAL	_____	95
	DEADBAND	_____	1.0			A2S2 VAL	_____	5
	OUT HYST	_____	0.5			A1S1TYPE	_____	NONE
	FAILMODE	_____	NO LAT			A1S2TYPE	_____	NONE
	FAILSAFE	_____	0.0			A2S1TYPE	_____	NONE
MAN OUT	_____	—	A2S2TYPE	_____		NONE		
AUTO OUT	_____	—	A1S1 H L	_____		HIGH		
PborGAIN	_____	GAIN	A1S1 EV	_____		--		
MINorRPM	_____	MIN	A1S2 H L	_____		LOW		
			A1S2 EV	_____		--		
			A2S1 H L	_____		HIGH		
			A2S1 EV	_____		--		
			A2S2 H L	_____	LOW			
			A2S2 EV	_____	--			
			AL HYST	_____	0.1			
			ALM OUT1	_____	NO LAT			
			BLOCK	_____	DISABL			
OPTIONS	AUX OUT	_____	DISABL					
	4mA VAL	_____	0.0					
	20mA VAL	_____	0					
	DIG IN 1	_____	NONE					
	DIG1 COM	_____	DISABL					
	DIG IN 2	_____	NONE					
			DISABL					
				DISPLAY	DECIMAL	_____	XXXX	
					TEMPUNIT	_____	NONE	
					PWR FREQ	_____	60 HZ	
					RATIO 2	_____	DISABL	
					LANGUAGE	_____	ENGLIS	

9. Appendix D – Position Proportional Calibration

9.1 Position Proportional Control Output Calibration

Introduction

When the UDC 3300 controller has a Position Proportional control output, calibrate the controller so that the increase and decrease relays operate properly with respect to the position of the external feedback slidewire.

Three Position Step Control Output Models **with** Motor Position Indication
(Model Numbers DC330X-EE-XXX-X2, DC330X-AA-XXX-02)

This model must have its output calibrated per the entire procedure to ensure the displayed output (slidewire position) agrees with the final control element position.

Three Position Step Control Output Models **without** Motor Position Indication
(Model Numbers DC330X-EE-XXX-X0, DC330X-AA-XXX-X0)

This model only requires that the “Motor Time” be entered as shown in the calibration procedure. FULL CALIBRATION IS NOT REQUIRED

Procedure

Apply power and allow the controller to warm up 30 minutes before you calibrate. Leave all field wiring connected to the rear terminals.

There are two ways in which to calibrate Position Proportional or 3 Position Step control: AUTO mode or MANUAL mode.

Rules for auto mode vs manual mode

The Auto-mode selection must be done at least once before the manual mode will operate properly. Failure to use the Auto-mode procedure will prevent the controller from going into automatic control mode.

During the Auto-mode calibration procedure, the values being displayed are used only to indicate if the motor is still traveling. To view the actual calibration value, use the manual mode after the Auto-mode is completed. These values can be changed for purposes of tweaking the calibration.

Make sure LOCKOUT in Tuning Set Up group is set to NONE.

For *Three Position Step Control Output models without Motor Position Indication*, do steps 1 and 2 only.

For *Position Proportional Output and Three Position Step Control Output models with Motor Position Indication*, follow the entire calibration procedure.

ATTENTION These prompts *only* appear when position OUT ALG is selected. If motor position for 3PSTEP is desired, first configure unit for “position.” After calibration the unit can be switched to 3PSTEP.

Table 9-1 Calibration Procedure

Step	Operation	Press	Action						
1	Enter Calibration Mode	SETUP	until you see <i>Upper Display: CALIB</i> <i>Lower Display: POS PROP</i>						
2	Set Motor Traverse Time	FUNCTION LOOP 1/2	Until you see <i>Upper Display: (A value)</i> <i>Lower Display: MTR TIME</i> NOTE: This is the time it takes the motor to travel from 0 to 100%.						
3		▲ or ▼	until the proper motor stroke time is reached (see the motor specs or measure the time) Range of setting = 5 to 1800 Seconds						
4	Select Automatic or Manual Calibration	FUNCTION LOOP 1/2	Until you see You can calibrate the controller output manually or let the controller calibrate the output automatically . If the slidewire has never been calibrated, you must use DO AUTO first. In the "Automatic Calibration Mode" (DO AUTO), the controller relays automatically move the motor in the proper direction. If desired, however, the motor may be manually positioned to 0% and 100% positions. Disconnect the relay wires. Use DO MAN. In the "Manual Calibration Mode" (DO MAN), the motor does not move. Instead, the existing 0% and 100% values may be changed with the ▲ or ▼ key.						
5		▲ or ▼	to select automatic or manual calibration. <i>Upper Display: DO AUTO or DO MAN</i> <i>Lower Display: POS PROP</i>						
			<table border="1"> <thead> <tr> <th>If you select...</th> <th>Then...</th> </tr> </thead> <tbody> <tr> <td>DO AUTO</td> <td>go to Step 6</td> </tr> <tr> <td>DO MAN</td> <td>go to Step 8</td> </tr> </tbody> </table>	If you select...	Then...	DO AUTO	go to Step 6	DO MAN	go to Step 8
If you select...	Then...								
DO AUTO	go to Step 6								
DO MAN	go to Step 8								
			ATTENTION When calibration is terminated, this selection reverts to DISABL.						
6	DO AUTO Set 0% value	FUNCTION LOOP 1/2	The decrement relay is turned on to move the motor to 0% position. <i>Upper Display: (Counts of Feedback Slidewire-0 to 3000)</i> <i>Lower Display: ZERO VAL</i> When the motor stops, the display should stop counting, then go to the next step.						

Step	Operation	Press	Action
7	DO AUTO Set 100 % value	<u>FUNCTION</u> LOOP 1/2	The increment relay is turned on to move the motor to 100 % position. <i>Upper Display:</i> (Counts of Feedback Slidewire-0 to 3000) <i>Lower Display:</i> SPAN VAL When the motor stops, the display should stop counting, then go to step 12.
8	DO MAN Set 0 % value	<u>FUNCTION</u> LOOP 1/2	You will see: <i>Upper Display:</i> (The existing zero calibration value in counts) <i>Lower Display:</i> ZERO VAL
9		▲ or ▼	until the desired zero value is reached in the upper display. <i>Upper Display:</i> (The desired zero value) <i>Lower Display:</i> ZERO VAL
10	DO MAN Set 100 % value	<u>FUNCTION</u> LOOP 1/2	The controller will store the 0% value and you will see: <i>Upper Display:</i> (The existing span calibration value in counts) <i>Lower Display:</i> SPAN VAL
11		▲ or ▼	until the desired span value is reached in the upper display. <i>Upper Display:</i> (The desired span value) <i>Lower Display:</i> SPAN VAL For manual calibration, the motor does not move from its position prior to the start of Position Proportional calibration.
12	Exit the Calibration Mode	<u>FUNCTION</u> LOOP 1/2 LOWER DISPLAY or SETUP	The controller will store the 100 % value. To exit the calibration mode.

10. Appendix E – Input Ranges

PV Input	Range	
	°F	°C
Thermocouples (Per ITS-90)		
B	0 to 3300	-18 to 1816
E	-454 to 1832	-270 to 1000
E (low)	-200 to 1100	-129 to 593
J	0 to 1600	-18 to 871
J (low)	20 to 770	-7 to 410
K	0 to 2400	-18 to 1316
K (low)	-20 to 1000	-29 to 538
NiNiMoly (NNM68)	32 to 2500	0 to 1371
NiNiMoly (low)	32 to 1260	0 to 682
NiMo-NiCo (NNM90)	32 to 2500	0 to 1371
NiMo-NiCo (low)	32 to 1260	0 to 682
Nicrosil Nisil (NIC)	0 to 2372	-18 to 1300
R	0 to 3100	-18 to 1704
S	0 to 3100	-18 to 1704
T	-300 to 700	-184 to 371
T (low)	-200 to 500	-129 to 260
W5W26	0 to 4200	-18 to 2315
W5W26 (low)	0 to 2240	-18 to 1227
Honeywell Radiamatic		
Type RH	0 to 3400	-18 to 1871
Type RI	0 to 9999 max.*	-18 to 9999 max.*
RTD IEC Alpha = 0.00385		
100 ohms	-300 to 1200	-184 to 649
100 ohms (low)	-300 to 300	-184 to 149
200 ohms	-300 to 1200	-184 to 649
500 ohms	-300 to 1200	-184 to 649
Linear		
Milliamps	4 to 20 mA 0 to 20 mA	
Millivolts	0 to 10 mV 0 to 50 mV	
Volts	1 to 5 V 0 to 5 V 0 to 10 V	
Carbon	0 to 1250 mV	
Oxygen	-30 to 510 mV	

*User enters the range manually per RI type and application

Honeywell

Sensing and Control
Honeywell
11 West Spring Street
Freeport, IL 61032

51-52-25-78 0500 Printed in USA

www.honeywell.com/sensing