

TYPE 1000 TRANSDUCER Product Instructions

Amine Plant
961-072-000
T-1000
Input 4-20mA
Output 3-15 psi

PRINCIPLE OF OPERATION

The Type 1000 transducer is a force balance device in which a coil is suspended in the field of a magnet by a flexure. Current flowing through the coil generates axial movement of the coil and flexure. The flexure moves against the end of a nozzle, and creates a back pressure in the nozzle by restricting air flow. This back pressure acts as a pilot pressure to an integral booster relay. Consequently, as the input signal increases (or decreases, for reverse acting), output pressure increases proportionally.

Zero and span are calibrated by turning easily accessible adjusting screws on the front face of the unit. The zero adjustment causes the nozzle to move relative to the flexure. The span adjustment is a potentiometer that limits the flow of current through the coil. A thermistor circuit in series with the coil provides temperature compensation.

MOUNTING

→ The T1000 can be mounted at any angle, but should be calibrated after mounting. For maximum output pressure stability, the Type 1000 should be mounted vertically in a vibration free location or such that the vibration is isolated to the X and Z axis as shown in **Figure 3**.

Pipe: Due to its light weight, the Type 1000 may be supported by the piping used for the supply and output.

Panel: (*with access to rear of panel*) Attach transducer (**See Fig. 3**), to panel using two 10-32 screws and two threaded mounting holes on the back of the unit.

Panel: (*with no access to rear of panel*) Attach bracket, Part Number 971-057-000 (**see Fig 1 & 3**), to transducer using two 10-32 screws on the back of the unit and mount bracket to panel using four 8-32 screws.

Pipe mount U-Bolt Option: The pipe mounting hardware is not standard. Attach the bracket from Valve Mounting Kit, (order 010134000) to transducer using two 10-32 screws. Place u-bolt from 2" Pipe Mounting Kit (order 010-143-000) around pipe and through the bracket. Place lock washers and nuts on u-bolt and tighten.

DIN Rail Mounting Kit Option: The DIN rail mounting kit is not standard. Order DIN Rail Kit (010115000).

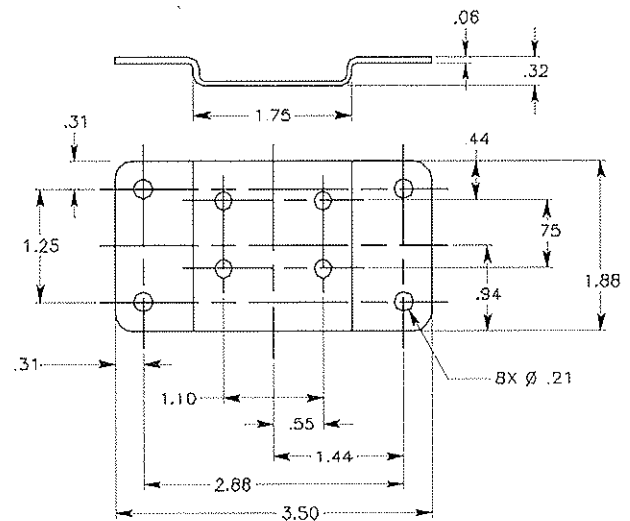

Figure 1

Warranties of Sale, disclaimer thereof and limitations of liability are covered exclusively by Marsh Bellofram's printed warranty statement for the T-1000 transducer. These instructions do not expand, reduce, modify or alter Marsh Bellofram's warranty statement and no warranty or remedy in favor of a customer or any other person arises out of these instructions.

AIR CONNECTIONS

- Supply Air must be instrument quality air regulated between the minimum and maximum specified on the nameplate of the transducer.
- Instrument quality air consists of :
 - a A dew point less than 35 deg. F
 - b No particles larger than three microns
 - c Maximum oil content of 1 ppm
- All unused ports must be plugged.

Supply: Connect supply to the 1/4 NPT ports marked "IN" on the base of the transducer. Avoid getting pipe sealant inside the piping or transducer.

Output: Connect output to the 1/4 NPT ports marked "OUT" on the base of the transducer. The pipe plugs may be removed from the two auxiliary output ports for a pressure gauge or as an alternative output port.

Note: On certain special models the pipe plugs are not factory installed, and must be installed air tight by the customer.

PRODUCT CERTIFICATIONS

FACTORY MUTUAL

INTRINSIC SAFETY: The Type 1000 (I / P Models 961-099-000 and 961-100-000) transducers are rated intrinsically safe by FM for:
- CLASS I, DIVISION 1, GROUPS A,B,C,D HAZARDOUS LOCATIONS when installed in accordance with interconnection drawing 229-541-000-012, and the specific barrier models.

NOTICE: The above ratings only apply when installed per Interconnection Drawing 229-541-000-012
- Nonincendive for CLASS I, DIVISION II, GROUPS A, B, C, D.

CANADIAN STANDARDS ASSOCIATION

INTRINSIC SAFETY: The Type 1000 Transducers, (models 961-105-000 and 961-106-000) are rated intrinsically safe by CSA when connected through certified diode safety barriers in accordance with Bellofram Installation diagram, 229-541-000-012

NOTICE: The above ratings only apply when installed per Interconnection Drawing 229-541-000-032

ELECTRICAL CONNECTIONS

PRECAUTIONS TO BE OBSERVED DURING INSTALLATION



The Bellofram T-1000 Transducers were tested at the EMC Test Centre, Dunfermline, Fife, KY11 5LB to the Electromagnetic Compatibility Directive effective January 1, 1996. The relevant EMC specifications tested were the following: EN 50081-1 (1992) and EN 50082-1 (1992). A Technical Construction File, Serial #107 was written and Certificate of Conformity issued by a Competent Body.

EN 50081-1 (1992): Test results confirmed that no precautions need to be observed during installation regarding electromagnetic emissions from the T-1000 Transducers.

EN 50082-1 (1992): The following precautions should be taken during installation to maintain the advertised accuracy specifications for the T-1000 Transducers. The input wiring to the transducer should be isolated from other high voltage transient wiring. The momentary switching on and off of nearby relays, motors, or other high capacitive or inductive loads can have a minor effect on the terminal based linearity specification (1.0% of span, standard range models) for the T-1000. Any change in output pressure is minimal and momentarily, and is considered to be within the performance capabilities of the T-1000. Use of a ferrite bead collar on the input wires entering the transducer is recommended should installation next to high electromagnetic interference be necessary.

Connect electrical signal to the wires exiting from the side of transducer through the 1/2" NPT conduit fitting.

For **DIRECT ACTING:** (where increasing the input signal increases output pressure), connect the positive input signal to the **black** transducer lead, and the negative to the **white** transducer lead.

For **REVERSE ACTING:** (where increasing the input signal decreases output pressure), connect the positive input signal to the **white** transducer lead, and the negative to the **black** transducer lead. Agency Approved Models may also be operated in either mode.

CALIBRATION

Once the transducer has been mounted, and air supply connections finished, the unit's calibration must be checked before placing into service. The plastic covers must be removed to gain access to the "ZERO" and "SPAN" adjustment screws. When calibration is completed, the covers should be replaced.

Note: input percentage refers to the following examples:

If 4 to 20 mA	If 10 to 50 mA
0 % = 4 mA	0 % = 10 mA
25 % = 8 mA	25 % = 20 mA
50 % = 12 mA	50 % = 30 mA
75 % = 16 mA	75 % = 40 mA
100 % = 20 mA	100 % = 50 mA

if 1 to 10 VDC	if 0 to 10 VDC	if 1 to 9 VDC	if 0 to 5 VDC	if 1 to 5 VDC
0 % = 1.00 VDC	0 % = 0.00 VDC	0 % = 1.00 VDC	0 % = 0.00 VDC	0 % = 1.00 VDC
25 % = 3.25 VDC	25 % = 2.50 VDC	25 % = 3.00 VDC	25 % = 1.25 VDC	25 % = 2.00 VDC
50 % = 5.50 VDC	50 % = 5.00 VDC	50 % = 5.00 VDC	50 % = 2.50 VDC	50 % = 3.00 VDC
75 % = 7.75 VDC	75 % = 7.50 VDC	75 % = 7.00 VDC	75 % = 3.75 VDC	75 % = 4.00 VDC
100 % = 10.00 VDC	100 % = 10.00 VDC	100 % = 9.00 VDC	100 % = 5.00 VDC	100 % = 5.00 VDC

Forward Acting

1. Apply the 0 % input signal to unit and adjust the "Zero" adjusting screw to the low setpoint output. Turn screw counter-clockwise to increase output. If there is no change in output, keep turning adjustment screw counter-clockwise until output begins to rise. It is imperative that the output pressure be closely monitored as turning the zero screw excessively could damage the flexure.
2. Apply the 100 % signal to unit and adjust "Span" adjusting screw until output is at the high setpoint.
3. **IMPORTANT:** On I / P (Current) input models, turn the "Span" adjusting screw **counter-clockwise** to increase output. On E / P (Voltage) input models, turn the "Span" adjusting screw **clockwise** to increase the output pressure.
4. Repeat steps 1 & 2 until unit is calibrated.

Reverse Acting

1. Apply the 0 % input signal to unit and adjust "Zero" adjusting screw until output reaches the high output pressure setpoint. Turn counter-clockwise to increase.
2. Apply the 100 % input signal to unit and adjust "Span" adjustment until output pressure is at the low setpoint.

IMPORTANT: On I / P (Current) input models, turn the "Span" adjusting screw **clockwise** to increase output. On E / P (Voltage) input models, turn the "Span" adjusting screw **counter-clockwise** to increase the output pressure.

3. Repeat steps 1 & 2 until unit is calibrated.

FIGURE 2

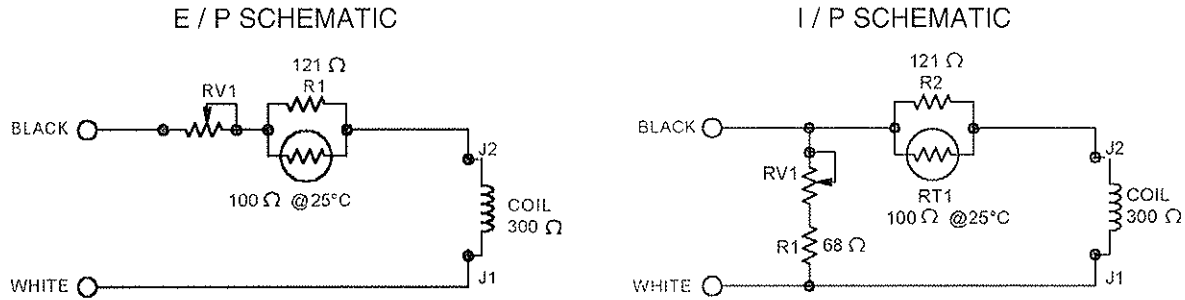

SIGNAL IMPEDANCE

The input impedance will vary depending upon the potentiometer setting of the “SPAN (RV1)”, (**SEE FIG. 2**). The I / P circuit design consists of a resistor and potentiometer in parallel with the coil / flexure. The E / P circuit utilizes a potentiometer in series with the coil / flexure. The following are some of the nominal impedences that would be measured across the signal leads of the average calibrated transducer. These values are helpful when determining power requirements and for trouble shooting.

INPUT SIGNAL	OUTPUT RANGE	NOMINAL IMPEDANCE (OHMS)	POTENTIOMETER RV 1 SIZE (OHMS)
4 - 20 mA	3 - 15 psi	180	1000
4 - 20 mA	3 - 27 psi	215	1000
4 - 20 mA	3 - 120 psi	260	1000
4 - 20 mA	2 - 60 psi	225	1000
10 - 50mA	3 - 15 psi	70	100
0 - 5 VDC	3 - 15 psi	615	500
0 - 5 VDC	3 - 27 psi	530	500
1 - 9 VDC	3 - 15 psi	985	1000
1 - 9 VDC	3 - 27 psi	840	1000
0 - 10 VDC	3 - 120 psi	800	1000

TROUBLESHOOTING

SYMPTOM	CAUSE	SOLUTION
Sluggish Performance or Reduced Range.	1) Plugged or blocked orifice.	1) Remove orifice screw and clean orifice with wire or pin <0.009 in. diameter
	2) Supply pressure too low.	2) Supply pressure must be at least 5 psi above the 100% output.
Transducer remains at start up no matter the input signal.	1) Zero set too low.	1) Turn zero adjustment counter-clockwise until output pressure increases then follow calibration procedure.
	2) Electrical connection has opened or wrong type of signal applied.	2) Check electrical connections to insure that there is a correct input signal reaching the transducer.
Transducer works in reverse. (Pressure goes down when input signal goes up.)	Wires connected in reverse	Insure wiring is connected per Electrical Connection section.
Output Pressure same as supply Pressure with no signal effect.	Pneumatic connections reversed or supply and output both connected to “IN” ports.	Insure supply is connected to port marked “IN” and output is connected to port marked “OUT”.

Note: If you experience an unusual problem that is not described in this section, or if troubleshooting procedures will not restore the unit to normal operation, please consult a factory applications engineer at (304)387-1200.

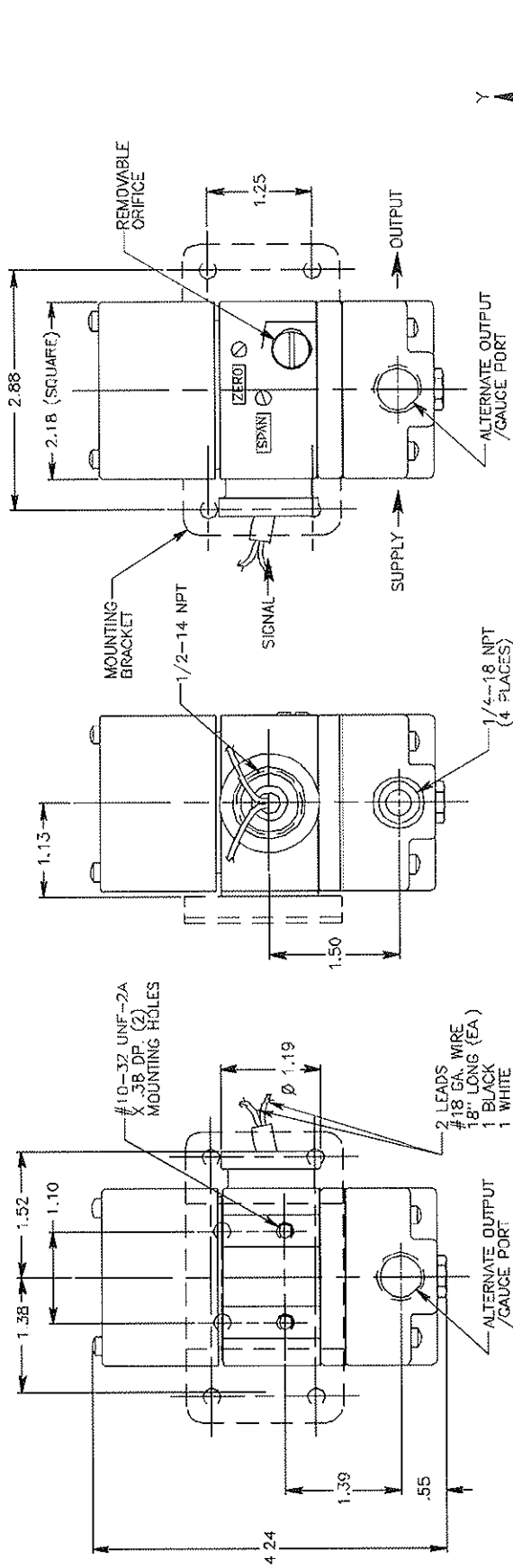

Figure 3 STANDARD UNIT

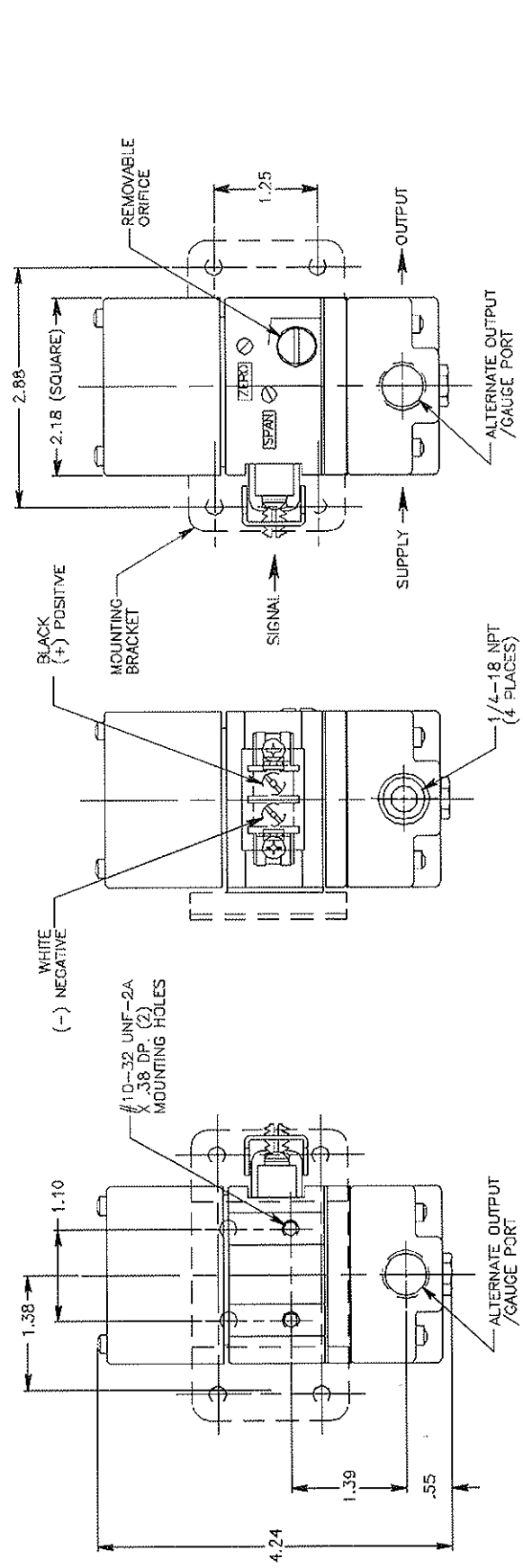

Figure 3 TERMINAL BLOCK UNIT