



Mini-Hermet Pressure Switches

Form 456

Mini-Hermet Pressure Switches

are robust field-mounted instruments. The pressure sensing assembly is similar to a conventional SOR type. The main difference is that the switching element assembly is hermetically sealed in an explosion proof steel capsule. Switching elements are SPDT or DPDT. See Principle description on page 2.

Application Information

The pressure switches in this catalog are suitable for a variety of process applications in hazardous locations and hostile environments where stainless steel exterior parts are required and where space is limited. Basic models with standard wetted parts are normally suitable for air, oil, water and non-corrosive process fluids. See the Quick Selection Guide on page 4. Corrosive service and particular user requirements may require optional components. See How to Order on page 3. Adjustable ranges to accommodate lower Set Points, switching elements to handle heavier electrical loads and user preference may require Big Hermet models.

High pressure fluid power (hydraulic) applications where high shock pressures and high cycle rates are expected normally require Pivot Seal type pressure switches.



Mini-Hermet Pressure Switches

Principle

The pressure sensing element of the SOR Pressure Switch is a force-balance, piston-actuated assembly. The sensing element is sealed by a flexible diaphragm and a static o-ring. There are only three wetted parts in this arrangement: a pressure port, a diaphragm and an o-ring. A wide selection of wetted parts materials for media compatibility and containment are available. A metal diaphragm may be welded to the pressure port for certain applications, thereby eliminating the o-ring (Designators U8 and U9).

Media pressure on the piston counteracts the force of the range spring (adjustable by the adjusting screw) which moves the piston shaft only a few thousandths of an inch to directly actuate the electrical snap-action switching element that is enclosed in the hermetically sealed steel capsule. This design results in low friction and virtually no wear. The electrical switching element is isolated from corrosive atmospheres.

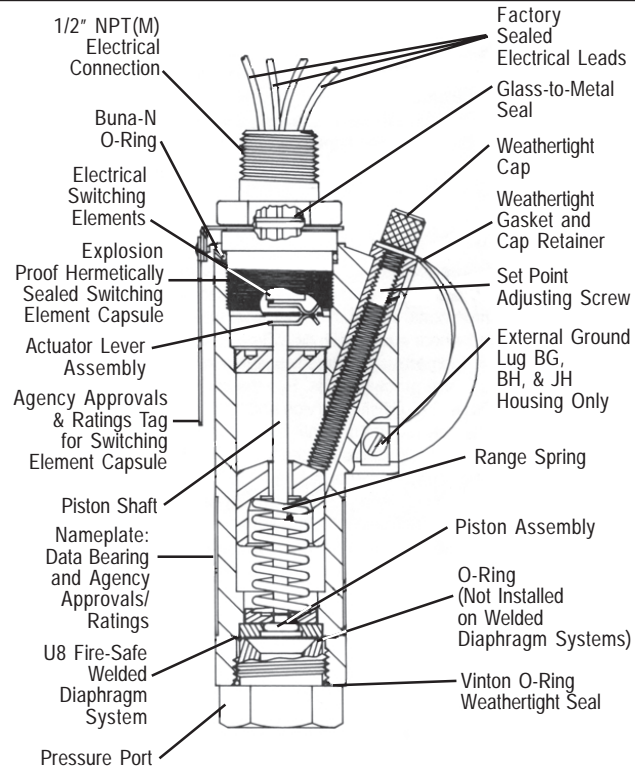

Features and Benefits

Built-In Quality

- Rigid quality standards maintained from raw material to finished product.

Explosion Proof Hermetically Sealed Switching Capsule

- Isolates switching elements from corrosive, hostile and hazardous environments and virtually eliminates problems from corrosion.

UL Listed, CENELEC (BASEEFA), CSA Certified, SAA and JIS/RIIS Approved Models

- Meet most code and customer requirements.

Field Adjustable Set Points

- Full range adjustability without disconnecting electrical power while maintaining explosion proof integrity, self-locking adjustment, no charge for factory calibration.

Warranty

- 3 years from date of manufacture.

Instrument Quality

- High resolution of Set Points, high repeatability, narrow dead band, negligible temperature effect, high overrange and proof pressures.

Robust Construction

- High cycle rate tolerance, long life, not critical to vibration, protected internal hermetically sealed switching element capsule.

Cost Effective

- Simple, fast installation without special tools, long service life. Periodic service or spare parts not required.

Delivery

- Routine shipments 7 to 10 working days. Emergency shipments via air within 48 hours.

Service

- Factory service engineers and area factory representatives provide effective and prompt worldwide service.

Model Number System

6AG-EF3-M4-C2A-YY



Quick Selection Guide

Basic Mini-Hermet pressure switches in AG or AH housings with standard wetted parts are normally suitable for air, oil, water and non-corrosive process applications in hazardous locations and hostile environments where space is limited. Refer to the Quick Selection Guide section on page 4 for a basic model number. Corrosive service and particular customer requirements may require optional components. Refer to How to Order section below to build a customized model number or the dedicated page to locate optional components, such as: switching elements, diaphragm systems, pressure ports and accessories. Each position in the model number, except Accessories, must have a designator.

Applications

Mini-Hermet pressure switches in the AG and AH housings are normally suitable for a variety of process applications in hazardous locations and hostile environments because the electrical switching elements are hermetically sealed in a stainless steel capsule that is UL Listed, CSA Certified and SAA Approved as an explosion proof snap switch. Specific customer or code requirements for the complete pressure switch to be UL Listed, CENELEC and CSA Certified or JIS/RIIS Approved can normally be met by specifying an AP, AS, BG, BH or JH housing and U8 diaphragm system. See pages 6, 7, 8 and 10 for details. Other application requirements can normally be met by selecting optional components, such as: switching elements, diaphragm systems and pressure ports. Certain applications may require customized specials. Consult the factory or the SOR representative in your area. Conventional explosion proof pressure switches for process applications are shown in Form 216.

High pressure fluid power (hydraulic) applications where high shock pressure and high cycle rates are expected normally require Pivot Seal type pressure switches. Refer to SOR Catalog 219.

How to Order

Information and data in this catalog are formatted to provide a convenient guide to assist instrument engineers, plant engineers and end users in selecting pressure switches for their unique applications.

Steps 1 through 5 required. Step 6 optional. Orders must have complete model numbers, i.e. each component must have a designator.

Step 1: Select Piston-Spring Adjustable Range/Set Point from **Specification** (page 5).
(Piston/Spring combination determines adjustable range.)

Step 2: Select **Housing** for type of pressure switch and service (page 6).

Step 3: Select electrical **Switching Element** for electrical service (page 7).

Step 4: Select **Diaphragm and O-Ring** for process compatibility and containment (page 8).

Step 5: Select **Pressure Port** for process compatibility and connection (page 9).

Step 6: Select **Accessories** required for service (page 11).

If Agency Approved, Certified or Listed pressure switches are required, see page 12 for components that must be specified.

Mini-Hermet Pressure Switches

Quick Selection

Basic Mini-Hermet pressure switches with AG - Aluminum or AH - Stainless Steel housings and standard wetted parts are normally suitable for air, oil, water and non-corrosive process in hazardous locations and hostile environments. The Set Point must be within the adjustable range. Refer to How to Order section on page 3 to locate optional components. Each position in the model number, except Accessories, must have a designator.

Pressure

Model Number	Adjustable Range psi	Typical Dead Band psi	Overrange psi	Proof psi
6AG - EF2 - N4 - F1A	7 to 30	1.6	1500	2500
6AG - EF3 - N4 - F1A	12 to 100	2.7		
6AG - EF5 - N4 - F1A	20 to 180	4.2		
6AG - EF45 - N4 - F1A	25 to 275	5.7		
5AG - EF3 - N4 - F1A	25 to 240	6.6		
5AG - EF5 - N4 - F1A	35 to 375	9.3		
5AG - EF45 - N4 - F1A	45 to 550	11.7		
9AG - EF4 - N4 - F1A	100 to 500	15.9	2500	6000
9AG - EF5 - N4 - F1A	200 to 1000	27.6		
9AG - EF45 - N4 - F1A	200 to 1750	45		
1AG - EF45 - N4 - F1A	500 to 4000	294	5000	6000

Vacuum

Model Number	Adjustable Range in. Hg vacuum to pressure	Typical Dead Band in. Hg	Overrange psi	Proof psi
56AG - EF216 - M2 - C1A	30 - 0 - 20	2.5	1500	2500
56AG - EF316 - M2 - C1A	30 - 0 - 160	3.5		

Standard Construction

1. Housing: AG–Aluminum or AH - Stainless Steel. See Housing and Dimensions pages for details.
2. Switching element: EF–SPDT 5A 250 VAC. See Switching Element page for optional switching elements.
3. Diaphragm & O-Ring: N4–primary (wetted) diaphragm TCP, o-ring (wetted) Buna-N. See Diaphragm & O-Ring page for optional diaphragm and o-ring systems.
4. Pressure port: F1A–Carbon steel 1/4" NPT(F). When AH - Stainless Steel housing is specified, pressure port must be C1A - 316SS 1/4" NPT(F). See Pressure Port page for optional pressure ports.
5. Dead band values are expressed as typical expected at mid-adjustable range with the standard EF switching element assembly installed. See Dead Band Considerations on page 7.

Mini-Hermet Pressure Switches

Step 1: Pressure Specification

6AG-EF3-M4-C2A-YY

This table is a listing of piston-spring combinations and the corresponding adjustable ranges, dead bands, overrange and proof pressures. Adjustable range is expressed for increasing pressure; the Set Point must be within the adjustable range. Dead band is expressed as typical. See Dead Band Considerations at the bottom of switching element page 7.

Piston-Spring Designator	Adjustable Range		Typical Dead Band		Overrange		Proof	
	psi	bar	psi	bar [mbar]	psi	bar	psi	bar
6 - 2	7 to 30	0.5 to 2	1.6	[114]	1500	100	2500	170
6 - 3	12 to 100	0.8 to 7	2.7	[184]				
6 - 5	20 to 180	1.4 to 12	4.2	[289]				
6 - 45	25 to 275	1.7 to 19	5.7	[393]				
5 - 3	25 to 240	1.7 to 16	6.6	0.5				
5 - 5	35 to 375	2.4 to 26	9.3	0.6				
5 - 45	45 to 550	3.1 to 38	11.7	0.8				
9 - 4	100 to 500	7 to 35	15.9	1.0	2500	170	6000	410
9 - 5	200 to 1000	14 to 70	27.6	1.9				
9 - 45	200 to 1750	14 to 120	45	3.1				
1 - 45	500 to 4000	35 to 275	294	20.3	5000	340	6000	410

Step 1: Vacuum Specification

56AG-EF216-M4-C2A-YY

This table is a listing of piston-spring combinations and the corresponding adjustable ranges, dead bands, overrange and proof pressures. SOR vacuum switches are compound; they will operate in either vacuum or pressure modes. Adjustable range is expressed from maximum vacuum decreasing to zero gauge and increasing to maximum pressure. Dead band is expressed as typical. See Dead Band Considerations on bottom of page 7. The Set Point must be within the adjustable range. A vacuum switch is generally better suited than a pressure switch for Set Points very near zero gauge.

Piston-Spring	Adjustable Range Vacuum - 0 Pressure		Typical Dead Band Vacuum Mode		Overrange		Proof	
	in. Hg	bar	in. Hg	[mbar]	psi	bar	psi	bar
56 - 216	30 - 0 - 20	1.0 - 0 - 0.7	2.5	[170]	1500	100	2500	170
56 - 316	30 - 0 - 160	1.0 - 0 - 5.4	3.5	[240]				

Notes

1. Dead band values are expressed as typical expected at mid-range with the standard EF switching element assembly installed. When optional switching elements are specified, corresponding dead band multipliers shown on page 7 must be applied.
2. Special ranges may be possible. Consult the factory or the SOR representative in your area.
3. Diaphragms may have an additional effect on dead band. Consult factory. See Notes on page 8.
4. Metric bar (mbar) values are practical equivalents of the reference English values; not necessarily exact mathematical conversions. This data appears on the product nameplate when metric engineering units are specified.

Mini-Hermet Pressure Switches

Step 2: Housing

6AG-EF3-M4-C2A-YY

Service	Description	Designator
Hazardous Locations (UL Listed, CSA Certified & SAA Approved Snap Switch)	Housing contains explosion proof snap switch for hazardous locations and hostile environments. UL Listed, CSA Certified Class I, Group A, B, C, D; Class II, Group E, F, G, Division 1 & 2 and SAA Approved Ex s IIC T6 IP65 Class I, Zone 1; DIP T6 IP65. See details Note 3, page 7. Electrical conduit connection 1/2" NPT(M). NEMA 4, 4X, IP65, IP66, IP67. Material: Copper-free aluminum*.	AG
Hazardous Locations (UL Listed, CSA Certified & SAA Approved Snap Switch)	Housing contains explosion proof snap switch for hazardous locations and hostile environments. UL Listed, CSA Certified Class I, Group A, B, C, D; Class II, Group E, F, G; Division 1 & 2 and SAA Approved Ex s IIC T6 IP65 Class I, Zone 1; DIP T6 IP65. See details Note 3, page 7. Electrical conduit connection 1/2" NPT(M). NEMA 4, 4X, IP65, IP66, IP67. Material: Stainless steel.	AH
Hazardous Locations (UL Listed/CSA Certified Pressure Switch)	UL Listed and CSA Certified pressure switch Class I, Group A, B, C, D; Class II, Group E, F, G; Division 1 & 2 for hazardous locations and hostile environments. See details, page 12. U8 fire-safe diaphragm system designator required. Electrical conduit connection 1/2" NPT(M). NEMA 4, 4X, IP65, IP66, IP67. Material: Copper-free aluminum*.	AP
Hazardous Locations (UL Listed/CSA Certified Pressure Switch)	UL Listed and CSA Certified pressure switch Class I, Group A, B, C, D; Class II, Group E, F, G; Division 1 & 2 for hazardous locations and hostile environments. See details, page 12. U8 fire-safe diaphragm system designator required. Electrical conduit connection 1/2" NPT(M). NEMA 4, 4X, IP65, IP66, IP67. Material: Stainless steel.	AS
Flammable Atmospheres (CENELEC Certified Pressure Switch)	CENELEC Certified pressure switch EEx d IIC T6 per EN 50-014 & 018 for flammable atmospheres and hostile environments. See details, page 12. Electrical conduit connection 1/2" NPT(M). NEMA 4, 4X, IP65. Material: Copper-free aluminum*.	BG
Flammable Atmospheres (CENELEC Certified Pressure Switch)	CENELEC Certified pressure switch EEx d IIC T6 per EN 50-014 & 018 for flammable atmospheres and hostile environments. See details, page 12. Electrical conduit connection 1/2" NPT(M). NEMA 4, 4X, IP65, IP66, IP67. Material: Stainless steel.	BH
Hazardous Locations (JIS/RIIS Approved Pressure Switch)	JIS/RIIS Approved pressure switch IIC T6 per JIS C 0903 for hazardous locations and hostile environments. See details, page 12. Electrical conduit connection 1/2" NPT(M). NEMA 4, 4X, IP65, IP66, IP67. Material: Stainless steel.	JH

Note

Mini Hermet pressure switches with AG and AH housings are not agency listed, certified or approved. However, the hermetically sealed electrical switching element capsules in them are UL Listed, CSA Certified and SAA Approved as explosion proof snap switches for hazardous locations. See page 14 for dimensional details.

*Consult factory.

Mini-Hermet Pressure Switches

Step 3: Switching Element

6AG-EF3-M4-C2A-YY

Service	Contact Form	Electrical Connection	AC Rating (See Note 1)		DC Rating (See Note 1)				Dead Band Multiplier	Designator
			volts	amps	volts	amps	volts	amps		
Normal AC/DC	SPDT	18" 18 AWG Color-Coded Stranded Wire Leads	250	11	125	.5*	30	5	1.5	AF
				5	125	.5*	30	5*	1.0	EF
	DPDT			11	125	.5*	30	5	3.0	AG
				5	125	.5*	30	5*	2.0	EG
Gold Contacts for Low Power Data Acquisition Interface	SPDT	1/2" NPT(M) Conduit Connection	125	1	-	-	30	1	1.0	JF
	DPDT			1	-	-	30	1	2.0	JG

Notes

- AC/DC electrical ratings in the table above are UL Listed, CENELEC (BASEEFA) and CSA Certified, SAA and JIS/RIIS Approved with the following conditions and exceptions:
 - JF and JG are not SAA and JIS/RIIS Approved.
 - DC electrical ratings are for resistive loads only.
 - DC ratings marked with an asterisk (*) are not agency approved, certified or listed but have been verified by testing or experience.
 - AF, AG, JF and JG are also CENELEC (BASEEFA) Certified for 0.5 amps 125 VDC (resistive) when used with a BG or BH housing.
- Switching Elements AG, EG and JG have two separate SPDT switching elements that are operated by a single lever for DPDT switching action. Simultaneous actuation or deactuation occurs at both increasing and decreasing Set Points. Two independent electrical circuits can be simultaneously switched, i.e. one AC and one DC.
- The hermetically sealed switching element capsule is UL Listed, CSA Certified and SAA Approved as an explosion proof snap switch per the table to the right.
- Ambient Temperature Limits: -40 to 167°F (-40 to 75°C)
- Electrical connections are 18" 18 AWG color-coded stranded wire leads unless Accessory TB (electrical junction box with screw terminals) is specified.

Agency	Hazardous Location Conditions	Designator
UL Listed CSA Listed	Class I, Group A, B, C, D Class II, Group E, F, G; Division 1 & 2	AF, EF, AG, EG, JF, JG
SAA Approved	Ex s IIC T6 IP65 Class I, Zone 1 DIP T6 IP65	AF, EF, AG, EG

6. Wire Lead Color Code

EF, AF, JF	Red	NC	(Normally Closed)
	Black	NO	(Normally Open)
	Blue	C	(Common)
EG, AG, JG	Green	G	(Ground - Earth)
	Red	NC1	(Normally Closed - 1)
	Black	NO1	(Normally Open - 1)
	Blue	C1	(Common - 1)
	Orange	NC2	(Normally Closed - 2)
	Brown	NO2	(Normally Open - 2)
Yellow	C2	(Common - 2)	
Green	G	(Ground - Earth)	

CAUTION: The hermetically sealed switching element capsule assembly has been precisely positioned in the housing; over-travel has been precisely adjusted and secured at the factory for optimum performance. Field replacement of the capsule is not practical and is not recommended. Removal or breakage of the tack weld voids the warranty. Movement of the capsule in the housing will degrade performance and could render the device inoperative.

Dead Band Considerations

- Dead band values are expressed as typical expected at mid-range with the standard EF switching element assembly installed. When optional switching elements are specified, corresponding dead band multipliers must be applied.
- Dead bands are fixed (non-adjustable).
- Dead band can be widened by selecting an optional switching element with a multiplier greater than 1.0. Example: Model 5AH-AG3-M4-C2A-YY
Typical Dead Band: 6 psi
AG Switching Element multiplier = 3.0
Typical Dead Band corrected for AG switching element:
6 x 3.0 = 18 psi

Switching Element Designators	Multplier
EF, JF	1.0
AF	1.5
EG, JG	2.0
AG	3.0

Mini-Hermet Pressure Switches

Step 4: Diaphragm and O-Ring

Notes

- N4 diaphragm system is standard, but requires a designator in the model number. It is normally suitable for air, oil, water and non-corrosive processes. M2 diaphragm system is standard on Number 56 vacuum switches.
- U8 designates the welded fire-safe diaphragm system. U8 must be specified for the complete pressure switch to be UL Listed and CSA Certified; it may be specified on CENELEC Certified models. See pages 10 and 12. 316SS is stocked. Not available on Number 1 piston or vacuum switches. Example: U8-C2A is a 316SS fire-safe welded diaphragm system.
- U9 designates a welded diaphragm system. Not available on vacuum switches. Example: U9-A1A is a Monel welded diaphragm system. See page 10.
- Other diaphragm and o-ring combinations maybe available. Consult the factory or the SOR representative in your area for more information.
- Wetted parts have been selected as representing the most suitable commercially available material for use in the service intended. However, they do not constitute a guarantee against corrosion or permeation, since processes vary from plant to plant and concentration of harmful fluids, gases or solids vary from time to time in a given process. Empirical experience by users should be the final guide. Alternate materials based on this are generally available.
- Specify N3 diaphragm system for high cycle rate, high shock applications where Buna-N and TCP are compatible with the process.
- This table shows allowable minimum and maximum temperatures for o-rings. Consult the factory for temperatures down to -65°F on fire-safe and welded metal diaphragm systems.

O-Ring Material	°F	°C
Viton	32 to 400	0 to 204
Viton GLT	-20 to 400	-29 to 204
Kalrez	0 to 400	-18 to 204
Aflas	25 to 400	-4 to 204
Buna-N		
Neoprene	-30 to 200	-34 to 93
EPR		
Fire-Safe/Welded Diaphragm System	-30 to 400	-34 to 204
TCP-Teflon Coated Polyimide Diaphragm	-30 to 400	-34 to 204

- Dead bands are slightly higher when using H, N3, N6, J4, J6, U or W series diaphragm options. Consult Factory.
- Diaphragm systems U8, U9 are not available on Number 56 vacuum switches.
- M9 diaphragm system is suitable for steam applications up to 400°F.

6AG-EF3-M4-C2A-YY

O-Ring (Wetted)	Diaphragm (Wetted)	Designator	
Viton	Monel	A4	
Kalrez		A6	
Viton	Hastelloy-B	H4	
Kalrez		H6	
Viton	Hastelloy-C	J4	
Kalrez		J6	
Viton	Carpenter-20	L4	
Kalrez		L6	
Viton GLT	316L SS	M1	
Buna-N		M2	
Viton		M4	
Neoprene		M5	
Kalrez		M7	
Aflas		M8	
EPR		M9 (See Note 10)	
Viton		N1	
Buna-N		TCP Teflon-Coated Polyimide	N3 (See Note 6)
Buna-N			N4 Standard (See Note 1)
Kalrez		N5	
Kalrez	Kalrez	N6	
EPR	TCP Teflon-Coated Polyimide	N7	
Aflas		N8	
Buna-N	Buna-N	P1	
Neoprene	Neoprene	R1	
Viton	Viton	S1	
Viton GLT		S2	
Buna-N	Tantalum	W2	
Viton		W4	
Neoprene		W5	
Kalrez		W6	
EPR Ethylene Propylene	EPR Ethylene Propylene	Y1	
None	Fire-Safe Welded	U8 (See Note 2)	
None	Welded	U9 (See Note 3)	

Mini-Hermet Pressure Switches

Step 5: Pressure Port

6AG-EF3-M4-C2A-YY

Piston		6, 5, 9, 1			56	
Process Connection Size		1/4" NPT(F)	1/2" NPT(F)	3/4" NPT(M)	1/4" NPT(F)	1/2" NPT(F)
Pressure Port Material	Carbon Steel Ledloy AX Wrought	F1A (Standard)	F2A	F3A	N/A	N/A
	316 Stainless Steel Wrought	C1A	C2A	C3A	C1A	C2A
	347 Stainless Steel Wrought	E1A	E2A	E3A	Consult factory for availability of Pressure Port Material and Process Connection Size	
	Carpenter 20 Stainless Steel Wrought	L1A	L2A	L3A		
	316L Stainless Steel Low Carbon	Z1A	Z2A	N/A		
	Brass (See Note 4) Half Hard Yellow Wrought	D1A	D2A	D3A		
	Hastelloy B	H1A	H2A	H3A		
	Hastelloy C	J1A	J2A	J3A		
	Monel	A1A	A2A	A3A		

Notes

1. Select designator for material and connection size. Large bold face designators denote those items generally available from stock. Small light face designators denote items with limited stock and possible long delivery.
2. 1/4" and 1/2" tapered BSP(F) pressure (designated B instead of A in the 3rd position) ports are available.
3. The standard material and connection size for Numbers 6, 5, 9 & 1 pressure ports with: aluminum housing is F1A - 1/4" NPT(F) carbon steel; stainless steel housing is C1A - 1/4" NPT(F) 316SS.
4. Brass not available on Piston Numbers 9 and 1.



5. Other materials such as PVC, Kynar, etc., are available. Denote unlisted material by specifying an X followed by the required connection size, and describe the material.

Examples:

- X2A = PVC pressure port with 1/2" NPT(F) connection.
 X1A = Titanium pressure port with 1/4" NPT(F) connection.

Non-metal pressure ports generally reduce proof pressure and may reduce overrange pressure. The pressure port material may limit the process temperature. Delivery may be longer than normal.

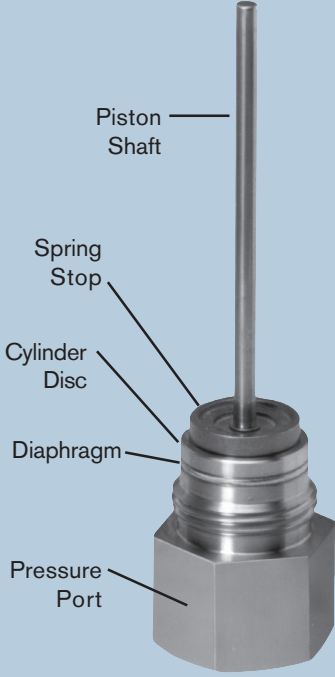
See next page for presentation of welded diaphragm and FM Approved fire-safe systems.

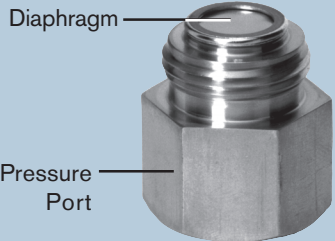
Designator	Description
<p>U8</p>  <p>Piston Shaft</p> <p>Spring Stop</p> <p>Cylinder Disc</p> <p>Diaphragm</p> <p>Pressure Port</p>	<div style="display: flex; justify-content: space-between; align-items: flex-start;"> <div style="width: 65%;"> <p>Fire-Safe Welded Diaphragm System Factory Mutual System Approved- U.S. Patent Number 4,438,305</p> <p>Tested in flames at 1900°F for periods up to 30 minutes while pressurized to the rated overrange pressure.</p> <p>A metal diaphragm, the cylinder disc and the pressure port are welded as a unit, thereby, eliminating the o-ring. This arrangement may be indicated for extremely corrosive, hot, harsh or volatile process where o-rings are not suitable. See fire-safe definition on page 13.</p> <p>316SS is standard. Hastelloy B and C, Monel and Titanium are available with possible longer lead times: The pressure port designator determines the material. Example: U8-C2A U8 = Fire-safe welded diaphragm system C2A = 1/2" NPT(F) 316SS pressure port</p> <p>Note 1/2" NPT(F) is stocked; 1/4" NPT(F) is not stocked and has a longer lead time. Not available on Number 1 piston and vacuum switches.</p> </div> <div style="width: 30%; text-align: center;">  </div> </div>
<p>U9</p>  <p>Diaphragm</p> <p>Pressure Port</p>	<p>Welded Diaphragm System</p> <p>A metal diaphragm is welded to the pressure port, thereby, eliminating the o-ring.</p> <p>This arrangement may be indicated for extremely corrosive, hot or harsh process where o-rings are not suitable.</p> <p>316SS is standard. Hastelloy B and C, Monel and Titanium are available with possible longer lead times: The pressure port designator determines the material. Example: U9-A2A U9 = Welded diaphragm A2A = 1/2" NPT(F) Monel pressure port</p> <p>Note Not available on vacuum switches.</p>

Mini-Hermet Pressure Switches

Step 6 : Accessories

6AG-EF3-M4-C2A-YY

Accessory / Option Description	Designator
Wetted parts are cleaned for industrial oxygen service.	BB
Universal terminal box, 1/2" NPT(F). 316SS. Explosion proof. CENELEC Certified EEx d IIC T4, T5, T6.	HB
Universal terminal box. M20 x 1.5(F). 316SS. Explosion proof. CENELEC Certified EEx d IIC T4, T5, T6.	HBME
Universal terminal box, 1/2" NPT(F). 316SS. Explosion proof. FM Approved; CSA Certified.	HT
Vacuum protector plate. Retains diaphragm in pressure switch if subjected to vacuum greater than 15 in. Hg. Material matches or exceeds pressure port material. N/A on piston 56.	MM
Compliance to NACE MR-01-75.	NC
Stainless steel piston and cylinder disc for higher overrange and proof. Consult factory.	PC
Pipe (stanchion) mounting kit for (1-1/2 to 2" pipe.)	PK
Tag, fiber. Attached with plastic wire to housing. Printed with customer specified tagging information.	PP
Tag, stainless steel. Attached with stainless steel wire to housing. Stamped with customer specified tagging information. (2 lines, 18 characters and spaces per line.)	RR
Explosion proof and weathertight electrical junction box with screw terminals. 3/4" NPT(F) top, left or right conduit connections as required. UL Listed and CSA Certified Class I, Groups A, B, C, D; Class II, Groups E, F, G; Division 1 & 2. (TA housing.) Includes cover o-ring for weathertight applications. Not available with BG, BH or JH housings.	TB
Oversize stainless steel nameplate or separate stainless steel tag. Permanently attached to housing. Stamped with customer specified tagging information.	TT
Fungicidal varnish. Covers exterior and interior except working parts.	VV
Epoxy coating. Exterior only. Polyamide epoxy with 316SS pigment.	YY
"X" is used as a suffix to the model number for special requirements not keyed elsewhere in the model number by an "X". Each "X" must be completely identified in the text of the order or inquiry. When more than one "X" is required, use "X" followed by the number of such items. For example, "X3 means three separate otherwise unidentifiable requirements.	X

Mini-Hermet Pressure Switches

Agency Approval

The chart below shows authorized combinations of components so that the complete pressure switch is approved, certified or listed by the cognizant agencies. Components or combinations of them may acquire additional approval, certification or listing prior to revision of this catalog. Contact the factory for the most current information.

UL Listed For Hazardous Locations Class I, Group A, B, C, D; Class II, Groups E, F, G; Division 1 & 2

Piston	Spring	Housing	Switching Element	Diaphragm System	Pressure Port Material and Connection Size	Accessories Options
5, 6, 9	2, 3, 4, 5, 45	AP, AS	AF, AG, EF, EG, JF, JG	U8	C1A C2A	BB, NC, NN, PK, PP, RR, TB, TT, VV, YY
Note: UL Listed models are suitable for handling petroleum-based, flammable and combustible liquids and gases, air, oxygen and water at fluid temperatures not exceeding 40°C and ambient temperature not exceeding 40°C.						

CSA Certified For Hazardous Locations Class I, Groups A, B, C, D; Class II, Groups E, F, G; Division 1 & 2

Piston	Spring	Housing	Switching Element	Diaphragm System	Pressure Port Material and Connection Size	Accessories Options
5, 6, 9	2, 3, 4, 5, 45	AP, AS	AF, AG, EF, EG, JF, JG	U8	C1A C2A	BB, HT, NC, PK, PP, RR, TB, TT, VV, YY

JIS/RIIS Approved For Hazardous Locations: Rating: Explosion Proof IIC T6

Piston	Spring	Housing	Switching Element	Diaphragm System	Pressure Port Material and Connection Size	Accessories Options
5, 6, 9	2, 3, 4, 5, 45	JH	AF, AG, EF, EG, JF, JG	U8	C1A, C1B, C2A, C2B	BB, PK, PP, RR, TT, VV, YY
1, 5, 6, 9				A4, M1, M2, M4, M5, M7, M8, N1, N3, N4, N5, N6, N7, N8, P1, R1, S1, S2, W2, W4, W5, W6, Y1	Material: A, B, C, D, E, F, H, J, L, Z Thread: 1A, 1B, 2A, 2B, 3A	N/A

CENELEC Certified For Flammable Atmospheres: Rating: EEx d IIC T6 per EN 50-014 & 018

Piston	Spring	Housing	Switching Element	Diaphragm System	Pressure Port Material and Connection Size	Accessories Options
5, 6, 9	2, 3, 4, 5, 45	BG, BH	AF, AG, EF, EG, JF, JG	U8, U9	All	BB, HB, HBME, PP, RR, TT, VV, YY
1, 5, 6, 9	2, 3, 4, 5, 45			A4, M1, M2, M4, M5, M7, M8, N1, N3, N4, N5, N6, N7, N8, P1, R1, S1, S2, W2, W4, W5, W6, Y1		

* Refer to Mini-Hermet Form 168 for special conditions for safe use.

SOR recognizes that there is no industry convention with respect to terminology and definitions pertinent to pressure switches. This glossary applies to SOR pressure with hermetically switching element capsules.

Pressure Switch

A bi-stable electromechanical device that actuates/deactuates one or more electrical switching element(s) at a predetermined discrete pressure/vacuum (Set Point) upon rising or falling pressure/vacuum.

Adjustable Range

The span of pressure between upper and lower limits within which the pressure switch can be adjusted to actuate/deactuate. It is expressed for increasing pressure.

Set Point

That discrete pressure at which the pressure switch is adjusted to actuate/deactuate on rising or falling pressure. It must fall within the adjustable range and be called out as increasing or decreasing pressure.

Dead Band

The difference in pressure between the increasing Set Point and the decreasing Set Point. It is expressed as typical, which is an average with the increasing Set Point at mid range for a pressure switch with the standard K switching element. It is normally fixed (non-adjustable).

Overrange

The maximum input pressure that can be continuously applied to the pressure switch without causing permanent change of Set Point, leakage or material failure.

Proof Pressure

The maximum input pressure that can be continuously applied to the pressure switch without causing leakage or catastrophic material failure. Permanent change of Set Points may occur, or the device may be rendered inoperative.

Repeatability

The ability of a pressure switch to successively operate at a Set Point that is approached from a starting point in the same direction and returns to the starting point over three consecutive cycles to establish a pressure profile. Repeatability on SOR switches will be smaller than 1% of full scale per ISA/ANSI S51.1.

SPDT Switching Element

Single-Pole, Double Throw (SPDT) has three connections: C – Common, NO – Normally Open and NC – Normally Closed, which allows the switching element to be electrically connected to the circuit in either NO or NC state.

DPDT Switching Element

DPDT is two synchronized SPDT switching elements which actuate together at increasing Set Point and deactuate together at decreasing Set Point. Discrete SPDT switching elements allow two independent circuits to be switched; i.e., one AC and one DC.

The synchronization linkage is factory set, and is not field adjustable. Synchronization is verified by connecting test lamps to the switching elements and observing them go “On” simultaneously at actuation and “Off” simultaneously at deactuation.

Fire-Safe

The ability of a welded seal pressure sensor to contain the process at elevated temperatures up to 1200°F at the rated overrange pressure, unsupported by the body of the pressure switch.

Hermetically Sealed

A welded steel capsule with glass-to-metal, factory-sealed, electrical leads that isolates the electrical switching element(s) from the environment.

Mini-Hermet Pressure Switches

Dimensions

Dimensions in this catalog are for reference only. They may be changed without notice. Contact the factory for certified drawings for a particular model number.

Notes

1. Dimensions on pages 14 and 15 are expressed as millimeters over inches (Linear = mm/in.).
2. Dimensions marked A-Length on housing dimension drawings vary with respect to process connection size. The chart below lists A-Lengths with reference to piston number and process connection size.

Process Connection Size	A-Length	
	Piston Number 6, 5, 9, 1	Piston Number 56
1/4" NPT(F)	157.2mm / 6.19 inch	175.5mm / 69.1 inch
1/2" NPT(F)	170.4 mm / 6.71 inch	
3/4" NPT(M)	180.3mm / 7.10 inch (outline not shown)	N/A

Housing Designator

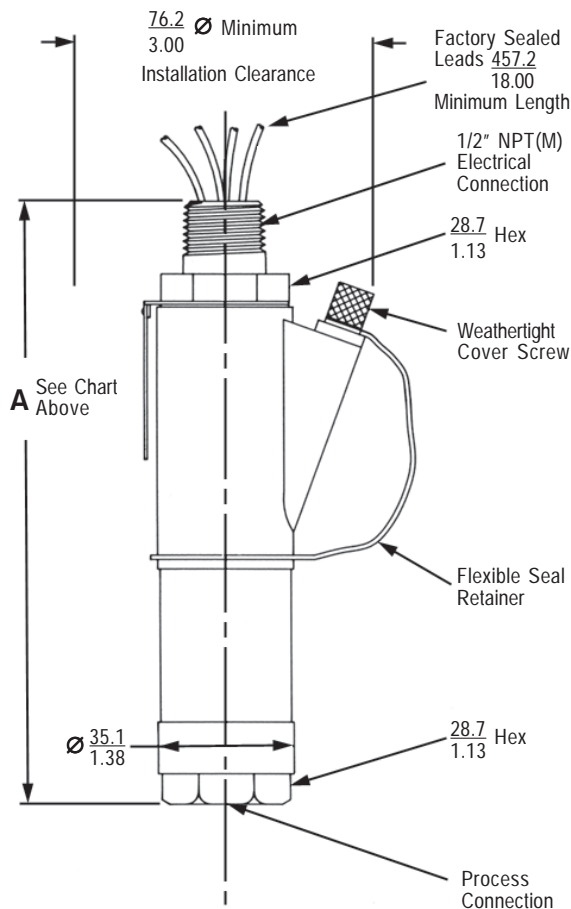

AH, AS

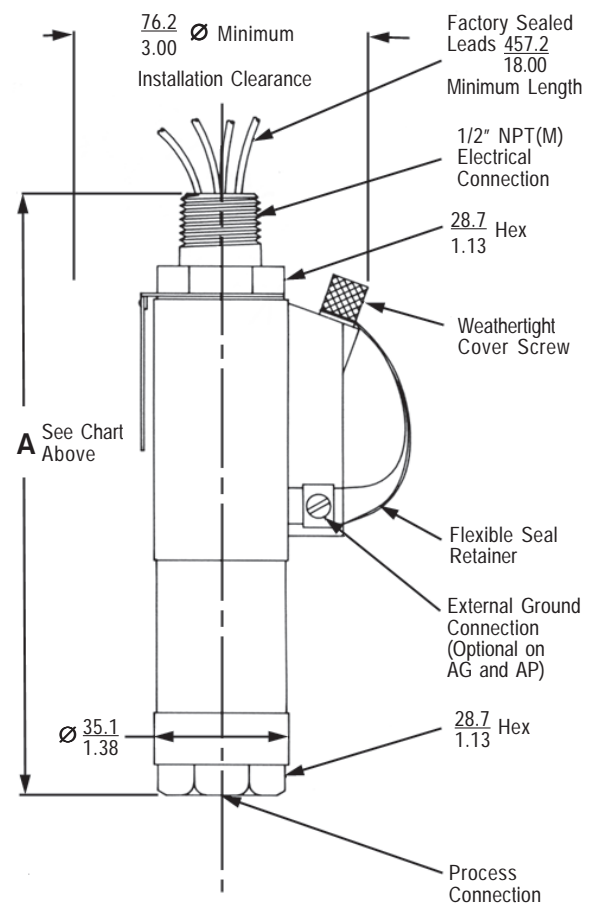

AG, AP, BG, BH, JH

Mini-Hermet Pressure Switches

Dimensions

Pipe Mounting Bracket - PK

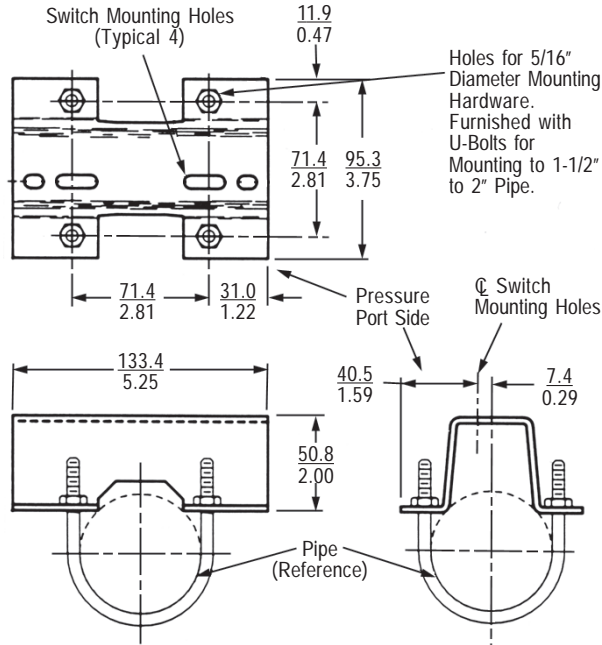

Junction Box with Terminal Block - TB

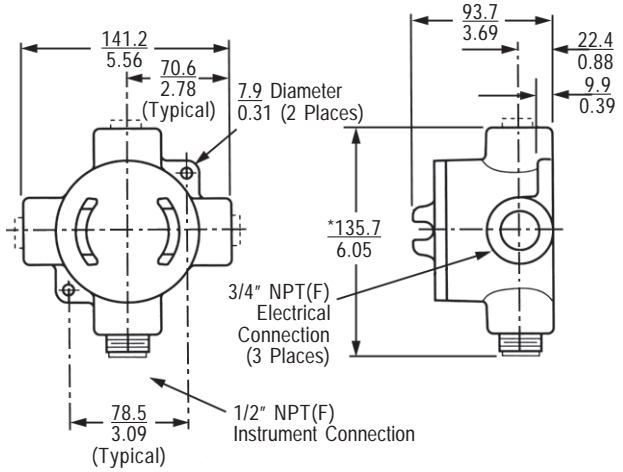

*Dimension shown is approximate and based on a 5-thread engagement.

Terminal Boxes - H Series

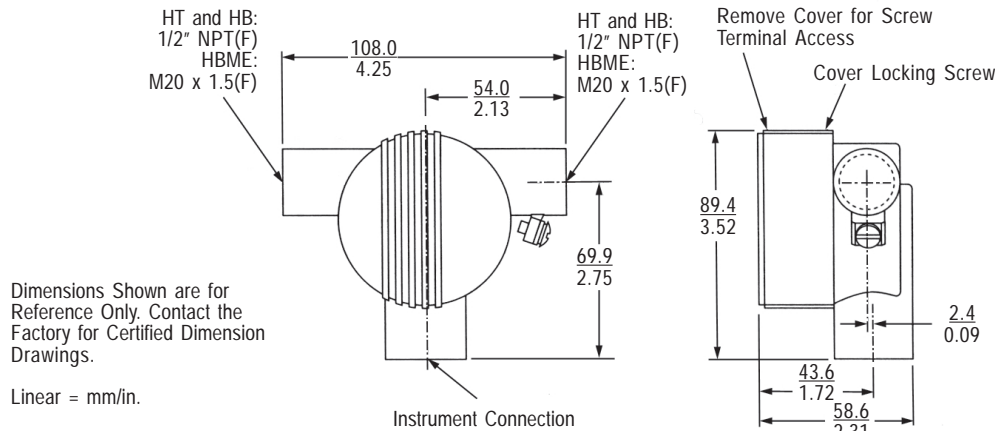

Dimensions Shown are for Reference Only. Contact the Factory for Certified Dimension Drawings.

Linear = mm/in.

Approximate Shipping Weight

Component	Designator	Weight (lbs)	(kgs)
Housing	AG, AP, BG	1.5	[0.7]
Housing	AH, AS, BH, JH	2.0	[1.0]
Junction Box	TB	(Add to housing) 5	[2.25]
Pipe Mounting Kit	PK	(Add to housing) 1.5	[0.7]
Terminal Box	HB, HBME, HT	(Add to housing) 2.0	[1.0]



Process Instrumentation

SOR INC.

14685 West 105th Street
Lenexa, Kansas 66215

Phone 913-888-2630
Toll Free 800-676-6794
Fax 913-888-0767

www.sorinc.com

Registered Quality System to ISO 9001

Form 456 (02.02) Printed in U.S.A.