

Model 8800C and Model 8800A Smart Vortex Flowmeter



Model 8800C and Model 8800A Smart Vortex Flowmeter

NOTICE

Read this manual before working with the product. For personal and system safety, and for optimum product performance, make sure you thoroughly understand the contents before installing, using, or maintaining this product.

Within the United States, Rosemount Inc. has two toll-free assistance numbers:

Customer Central

Technical support, quoting, and order-related questions.

1-800-999-9307 (7:00 am to 7:00 pm CST)

North American Response Center

Equipment service needs.

1-800-654-7768 (24 hours—includes Canada)

Outside of the United States, contact your local Rosemount representative.

⚠ CAUTION

The products described in this document are NOT designed for nuclear-qualified applications. Using non-nuclear qualified products in applications that require nuclear-qualified hardware or products may cause inaccurate readings.

For information on Rosemount nuclear-qualified products, contact your local Rosemount Sales Representative.

May be protected by one or more of the following U.S. Patent Nos. 4,464,936; 4,926,695. May depend on model. Other foreign patents issued and pending.

Rosemount, the Rosemount logotype, Fisher-Rosemount, Managing the Process Better, and PlantWeb are marks of one of the Fisher-Rosemount group of companies.

HART is a registered trademark of the HART Communication Foundation.

Hastelloy C is a registered trademark of Haynes International Inc.

Inconel is a registered trademark of International Nickel Co.

Cover photo: 8800-8800C918

Rosemount Inc.

8200 Market Boulevard
Chanhassen, MN 55317
USA
Tel 1-800-999-9307
Fax (952) 949-7001
© 2000 Rosemount, Inc.

Fisher-Rosemount Flow

Groeneveldselaan 6-8
3903 AZ Veenendaal
The Netherlands
Tel 31 (0) 318 549 549
Fax 31 (0) 318 549 559
Tel 0800-966-180 (U.K. only)
Fax 0800-966-181 (U.K. only)

Fisher-Rosemount

Singapore Pte Ltd.
1 Pandan Crescent
Singapore 128461
Tel (65) 777-8211
Fax (65) 777-0947
APRMT-Specialist@frco.com



00809-0100-4003, Rev. JA, 4/01

ROSEMOUNT®



Fisher-Rosemount satisfies all obligations coming from legislation to harmonise product requirements in the European Union.

Product documentation available at...
www.rosemount.com

EMERSON™
Process Management

Rosemount Model 8800C Vortex Flowmeter



Table of Contents

SECTION 1	
Introduction	How to Use this Manual 1-1
	Safety Messages 1-1
SECTION 2	
Installation	Safety Messages 2-1
	Commissioning 2-3
	General Considerations 2-3
	Flowmeter Sizing 2-3
	Flowmeter Orientation 2-3
	Wetted Material Selection 2-5
	Environmental Considerations 2-5
	Hazardous Locations 2-6
	Hardware Configuration 2-6
	Failure Mode vs. Saturation Output Values 2-7
	LCD Indicator Option 2-8
	Installation Tasks 2-8
	Handling 2-8
	Flow Direction 2-8
	Gaskets 2-8
	Flange Bolts 2-9
	Wafer-Style Flowmeter Alignment and Mounting 2-10
	Flanged-Style Flowmeter Mounting 2-12
	Flowmeter Grounding 2-13
	Electronics Considerations 2-13
	Conduit Connections 2-13
	High-Point Installation 2-13
	Cable Gland 2-14
	Grounding the Transmitter Case 2-14
	Wiring Procedure 2-27
	Remote Electronics 2-31
	Calibration 2-32
	Software Configuration 2-32
	Options 2-33
	LCD Indicator 2-33
	Installing the Indicator 2-34
	Diagnostic Messages 2-35
	Transient Protection 2-36
	Installing the Transient Protector 2-36

**SECTION 3
Operation**

Review 3-1
Process Variables 3-1
 Totalizer 3-2
Diagnostics/Service 3-3
 Test/Status 3-3
 Loop Test. 3-3
 Pulse Output Test. 3-3
 Flow Simulation 3-3
 D/A Trim 3-5
 Scaled D/A Trim 3-5
 Shed Freq at URV. 3-5
Basic Setup. 3-5
 Tag. 3-5
 Service Type 3-5
 PV Units 3-6
 Range Values 3-10
 Process Temperature 3-10
 Mating Pipe ID (Inside Diameter) 3-11
 Damping 3-11
Advanced Functionality. 3-12
Detailed Set-Up 3-12
 Characterize Meter. 3-12
 PV Units 3-14
 Configure Options. 3-14
 HART Output 3-17
 Signal Processing 3-20
 Device Information 3-23

**SECTION 4
Hardware and Software
Maintenance and
Troubleshooting**

Safety Messages. 4-1
Troubleshooting Tables 4-3
Advanced Troubleshooting 4-6
 TP1 4-7
 Shedding Frequency Out 4-9
Testing procedures. 4-9
Hardware Replacement. 4-10
 Replacing the Terminal Block in the Housing 4-11
 Replacing the Electronics Boards 4-12
 Replacing the Electronics Housing 4-13
 Replacing the Sensor 4-15
 Replacing the Sensor: Removable and
 Integral Support Tubes 4-17
 Remote Electronics Procedure 4-22
 Coaxial Cable at the Electronics Housing. 4-25
 Changing the Housing Orientation 4-26
Return of Material 4-27

APPENDIX A	Functional Specifications	A-1
Reference Data	Performance Specifications	A-6
	Physical Specifications	A-11
	Hazardous Locations Certifications	A-13
	European Atex Directive Information	A-16
	Ordering Information	A-17
APPENDIX B		
Approvals		
APPENDIX C	Connections and Hardware	C-6
HART Communicator	Diagnostic Messages	C-7
APPENDIX D	Diagnostics Messages	D-4
Model 268 Communicator		
APPENDIX E	Safety Messages	E-1
Electronics Verification	Electronics Verification	E-2
	Electronics Verification Using Flow Simulation Mode	E-2
	Fixed Flow Rate Simulation	E-2
	Varying Flow Rate Simulation	E-2
	Electronics Verification Using an	
	External Frequency Generator	E-3
	Calculating Output Variables with Known Input Frequency	E-4
	Examples	E-6
	English Units	E-6
	SI Units	E-9

Introduction

How to Use this Manual	page 1-1
Safety Messages	page 1-1

HOW TO USE THIS MANUAL

This manual provides installation, configuration, troubleshooting, and other procedures for the use of the Rosemount Model 8800C Smart Vortex Flowmeter. Specifications and other important information are also included.

Section 2: Installation

provides assistance in hardware configuration and lists the options available to customers for the Model 8800C.

Section 3: Operation

describes the Model 8800C software functions, configuration parameters, and other online variables. The descriptions are provided according to the function you want to perform.

Section 4: Hardware and Software Maintenance and Troubleshooting

supplies troubleshooting tables to lead you through any problems that may arise in the use of the Model 8800C. There are also instructions on basic maintenance of your Model 8800C.

Appendix A: Reference Data

gives reference and specification data for the Model 8800C and its applications.

Appendix B: Approvals

shows accompanying drawings for the Model 8800C FM and CSA approvals and certifications.

Appendix C: HART Communicator

provides command tree, and Fast Key Sequence tables for the HART Communicator when used in conjunction with the Model 8800C.

Appendix D: Model 268 Communicator

supplies command tree, and Fast Key Sequence tables for the Model 268, when used in conjunction with the Model 8800C.

Appendix E: Electronics Verification

provides a short procedure for verification of electronic output to assist in meeting the quality standards for ISO 9000 certified manufacturing processes.

SAFETY MESSAGES

Procedures and instructions in this manual may require special precautions to ensure the safety of the personnel performing the operations. Refer to the safety messages, listed at the beginning of each section, before performing any operations.

Installation

Safety Messages	page 2-1
Commissioning	page 2-3
General Considerations	page 2-3
Hazardous Locations	page 2-6
Hardware Configuration	page 2-6
Installation Tasks	page 2-8
Software Configuration	page 2-32
Options	page 2-33
LCD Indicator	page 2-33
Transient Protection	page 2-36

This section provides installation instructions for the Model 8800C Vortex Flowmeter. Dimensional drawings for each Model 8800C variation and mounting configuration are included in this section.

The options available for the Model 8800C flowmeter are also described in this section. The numbers in parentheses refer to the codes used to order each option.

SAFETY MESSAGES

Instructions and procedures in this section may require special precautions to ensure the safety of the personnel performing the operations. Please refer to the following safety messages before performing any operation in this section.

⚠ WARNING

Explosions could result in death or serious injury:

- Do not remove the transmitter cover in explosive atmospheres when the circuit is alive.
- Before connecting a HART-based communicator in an explosive atmosphere, make sure the instruments in the loop are installed in accordance with intrinsically safe or non-incendive field wiring practices.
- Verify that the operating atmosphere of the transmitter is consistent with the appropriate hazardous locations certifications.
- Both transmitter covers must be fully engaged to meet explosion-proof requirements.

⚠ WARNING

Failure to follow these installation guidelines could result in death or serious injury:

- Make sure only qualified personnel perform the installation.

Rosemount Model 8800C Vortex Flowmeter

Figure 2-1. Installation Flowchart

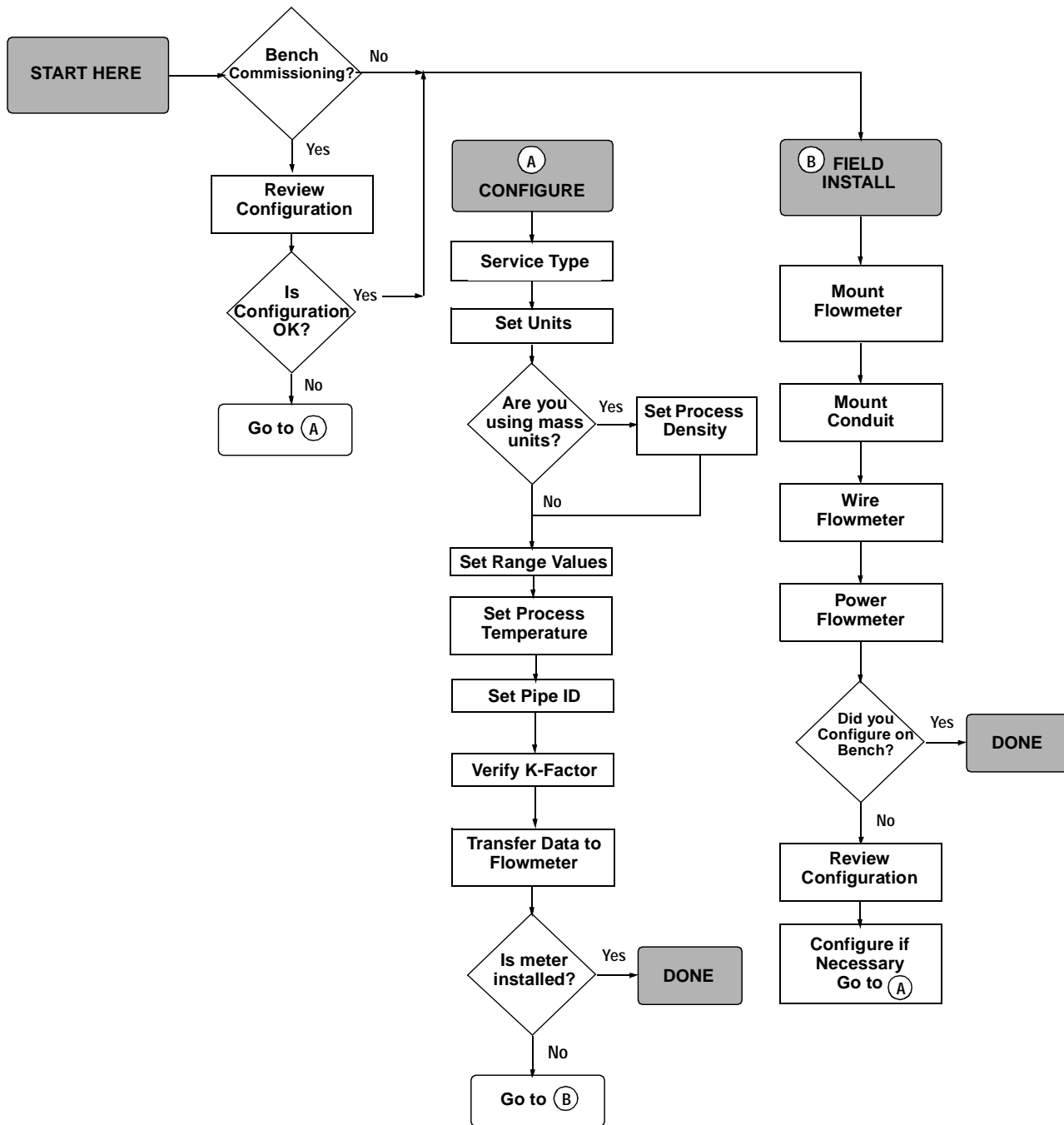

COMMISSIONING

Commission the Model 8800C before putting it into operation. This ensures proper configuration and operation of the meter. It also enables you to check hardware settings, test the flowmeter electronics, verify flowmeter configuration data, and check output variables. Any problems can be corrected – or configuration settings changed – before going out into the installation environment. To commission on the bench, connect the HART[®] Communicator or Asset Management Solutions[™] (AMS) software (or other communications device) to the signal loop in accordance with the specifications for your communicator. See Appendices C, D, and E for additional information.

**GENERAL
CONSIDERATIONS**

Before you install a flowmeter in any application, you must consider flowmeter sizing (the line size) and location. Choose the correct flowmeter size for an application to increase rangeability and minimize pressure drop and cavitation. Proper location of the flowmeter can ensure a clean and accurate signal. Follow the installation instructions carefully to reduce start-up delays, ease maintenance, and ensure optimum performance.

Flowmeter Sizing

Correct meter sizing is important for flowmeter performance. The Model 8800C is capable of processing signals from flow applications within the limitations described in Appendix A: Reference Data. Full scale is continuously adjustable within these ranges.

To determine the correct flowmeter size for an application, process conditions must be within the stated requirements for Reynolds number and velocity. See Appendix A: Reference Data for sizing data.

Contact your local Rosemount Inc. sales representative to obtain a copy of the Model 8800C Vortex Flowmeter Sizing Program which calculates flowmeter sizes based on user-supplied input.

Flowmeter Orientation

Design process piping so the meter body will remain full, with no entrapped air. Allow enough straight pipe both upstream and downstream of the meter body to ensure a nonskewed, symmetrical profile. Install valves downstream of the meter when possible.

Vertical Installation

Vertical installation allows upward process liquid flow and is generally preferred. Upward flow ensures that the meter body always remains full and that any solids in the fluid are evenly distributed.

The vortex meter can be mounted in the vertical down position when measuring gas or steam flows. This type of application should be strongly discouraged for liquid flows, although it can be done with proper piping design.

NOTE

To ensure that the meter body remains full, avoid downward vertical liquid flows where back pressure is inadequate.

High-Temperature Installations

Install the meter body so the electronics are positioned to the side of the pipe or below the pipe as shown in Figure 2-2. Insulation may be required around the pipe to maintain a temperature below 185 °F (85 °C).

Figure 2-2. Examples of High-Temperature Installations

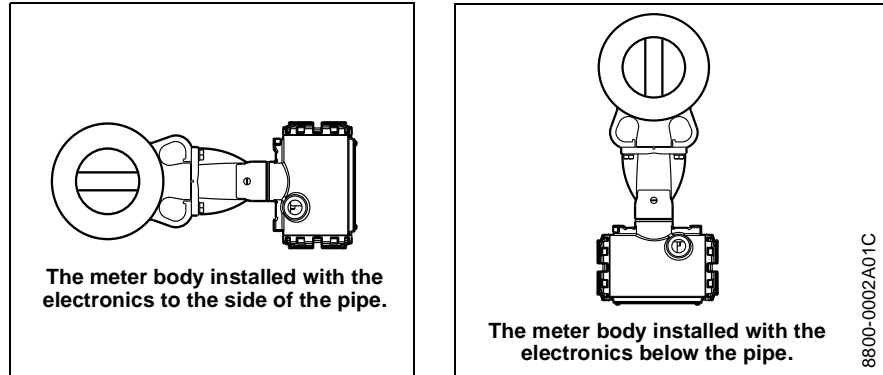

Steam Installations

For steam applications, avoid installations, such as the one shown in Figure 2-3. Such installations may cause a water-hammer condition at start-up due to trapped condensate. The high force from the water hammer can over stress the sensing mechanism and cause permanent damage to the sensor.

Figure 2-3. Avoid This Type of Installation for Steam Applications

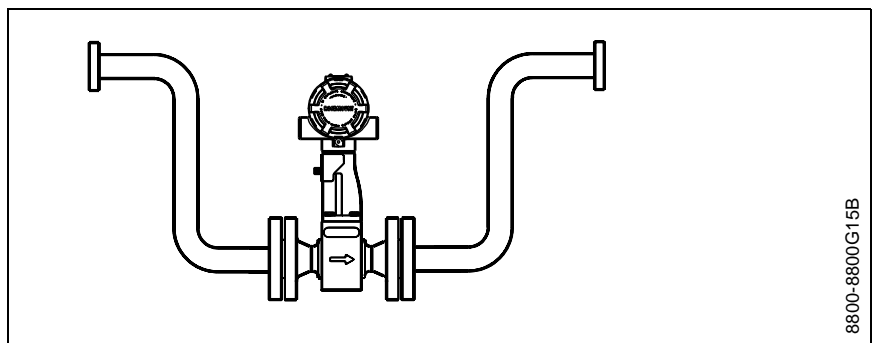

Upstream/Downstream Piping

The vortex meter may be installed with a minimum of *ten straight pipe diameters (D) upstream and five straight pipe diameters (D) downstream.*

Rated accuracy is based on the number of pipe diameters from an upstream disturbance. An additional 0.5% shift in K-factor may be introduced between 10 D and 35 D, depending on disturbance. For more information on installation effects, see Technical Data Sheet 00816-0100-3250. This effect can also be corrected in the electronics. See Installation Effect on page 3-13.

Pressure and Temperature Transmitter Location

When using pressure and temperature transmitters in conjunction with the Model 8800C for compensated mass flows, install the transmitter downstream of the Vortex Flowmeter. See Figure 2-4.

Figure 2-4. Pressure and Temperature Transmitter Location

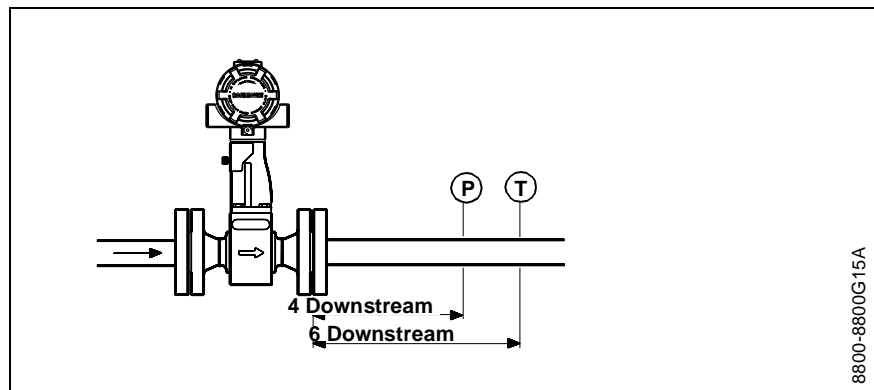

Wetted Material Selection

Ensure that the process fluid is compatible with the meter body wetted materials when specifying the Model 8800C. Corrosion will shorten the life of the meter body. Consult recognized sources of corrosion data or contact your Rosemount Sales Representative for more information.

Environmental Considerations

Avoid excessive heat and vibration to ensure maximum flowmeter life. Typical problem areas include high-vibration lines with integrally mounted electronics, warm-climate installations in direct sunlight, and outdoor installations in cold climates.

Although the signal conditioning functions reduce susceptibility to extraneous noise, some environments are more suitable than others. Avoid placing the flowmeter or its wiring close to devices that produce high intensity electromagnetic and electrostatic fields. Such devices include electric welding equipment, large electric motors and transformers, and communication transmitters.

HAZARDOUS LOCATIONS

The Model 8800C has an explosion-proof housing and circuitry suitable for intrinsically safe and non-incendive operation. Individual transmitters are clearly marked with a tag indicating the certifications they carry. See Section A: Reference Data for specific approval categories.

HARDWARE CONFIGURATION

The hardware jumpers on the Model 8800C enable you to set the alarm and security. (See Figure 2-5.) To access the jumpers, remove the electronics housing cover from the end of the Model 8800C. If your Model 8800C does not include an LCD indicator, the jumpers are accessible by removing the cover on the electronics side. If your Model 8800C includes an LCD option, the alarm and security jumpers are found on the face of the LCD indicator. (See Figure 2-6 on page 2-8.)

NOTE

If you will be changing configuration variables frequently, it may be useful to leave the security lockout jumper in the OFF position to avoid exposing the flowmeter electronics to the plant environment.

Set these jumpers during the commissioning stage to avoid exposing the electronics to the plant environment.

Figure 2-5. Alarm and Security Jumpers

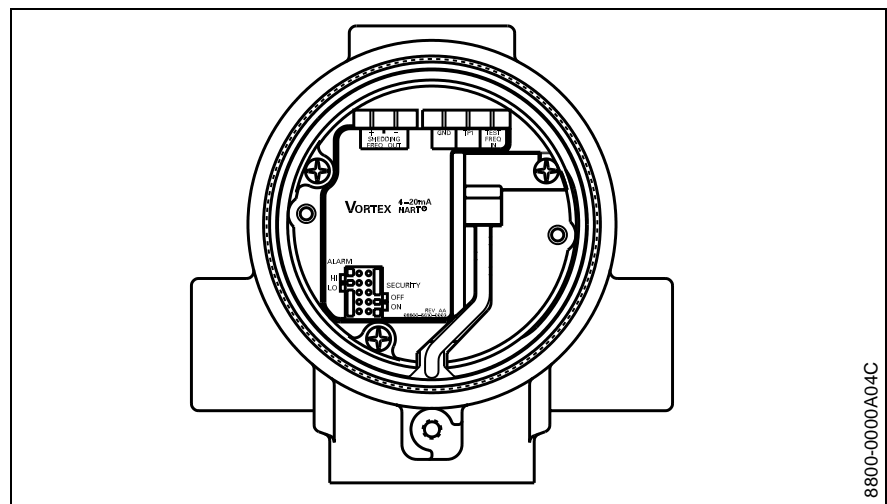

Alarm

As part of normal operations, the Model 8800C continuously runs a self-diagnostic routine. If the routine detects an internal failure in the electronics, flowmeter output is driven to a low or high alarm level, depending on the position of the failure mode jumper. The jumper is set per the CDS; the default setting is HIGH.

The failure mode jumper is labeled ALARM and is set to the high position at the factory.

Security

You can protect the configuration data with the security lockout jumper. With the security lockout jumper on, any configuration changes attempted on the electronics are disallowed. You can still access and review any of the operating parameters and scroll through the available changes, but no actual changes will be permitted. The jumper is set per CDS; the default setting is OFF.

Failure Mode vs. Saturation Output Values

The failure mode alarm output levels differ from the output values that occur when the operating flow is outside the range points. When the operating flow is outside the range points, the analog output continues to track the operating flow until reaching the saturation value listed below; the output does not exceed the listed saturation value regardless of the operating flow. For example, with standard alarm and saturation levels and flows outside the 4–20 mA range points, the output saturates at 3.9 mA or 20.8 mA. When the transmitter diagnostics detect a failure, the analog output is set to a specific alarm value that differs from the saturation value to allow for proper troubleshooting.

Table 2-1. Analog Output: Standard Alarm Values vs. Saturation Values

Level	4–20 mA Saturation Value	4–20 mA Alarm Value
Low	3.9 mA	≤ 3.75 mA
High	20.8 mA	>21.75 mA

Table 2-2. Analog Output: NAMUR-Compliant Alarm Values vs. Saturation Values

Level	4–20 mA Saturation Value	4–20 mA Alarm Value
Low	3.8 mA	≤ 3.6 mA
High	20.5 mA	>22.5 mA

LCD Indicator Option

If your electronics are equipped with the LCD indicator (Option M5), the ALARM and SECURITY jumpers are located on the face of the indicator as shown in Figure 2-6.

Figure 2-6. LCD Indicator Alarm and Security Jumpers

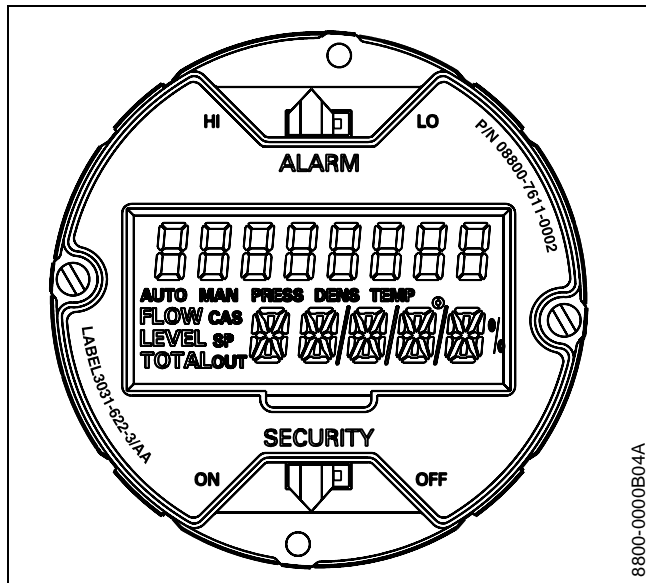

INSTALLATION TASKS

The installation tasks include detailed mechanical and electrical installation procedures.

Handling

Handle all parts carefully to prevent damage. Whenever possible, transport the system to the installation site in the original shipping containers. Keep the shipping plugs in the conduit connections until you are ready to connect and seal them.

Flow Direction

Mount the meter body so the FORWARD end of the flow arrow, shown on the meter body, points in the direction of the flow through the body.

Gaskets

The Model 8800C requires gaskets supplied by the user. Be sure to select gasket material that is compatible with the process fluid and pressure ratings of the specific installation.

NOTE

Ensure that the inside diameter of the gasket is larger than the inside diameter of the flowmeter and adjacent piping. If gasket material extends into the flow stream, it will disturb the flow and cause inaccurate measurements.

Flange Bolts

Install the Model 8800C Flowmeter between two conventional pipe flanges, as shown in Figure 2-7 and Figure 2-8 on page 2-11. Table 2-3, 2-4, and 2-5 lists the recommended minimum stud bolt lengths for wafer-style meter body size and different flange ratings.

Table 2-3. Minimum Recommended Stud Bolt Lengths for Wafer Installation with ASME B16.5 (ANSI) Flanges

Line Size	Minimum Recommended Stud Bolt Lengths (in Inches) for Each Flange Rating		
	Class 150	Class 300	Class 600
½-inch	6.00	6.25	6.25
1-inch	6.25	7.00	7.50
1½-inch	7.25	8.50	9.00
2-inch	8.50	8.75	9.50
3-inch	9.00	10.00	10.50
4-inch	9.50	10.75	12.25
6-inch	10.75	11.50	14.00
8-inch	12.75	14.50	16.75

Table 2-4. Minimum Recommended Stud Bolt Lengths for Wafer Installation with DIN Flanges

Line Size	Minimum Recommended Stud Bolt Lengths (in mm) for Each Flange Rating			
	PN 16	PN 40	PN 64	PN 100
DN 15	160	160	170	170
DN 25	160	160	200	200
DN 40	200	200	230	230
DN 50	220	220	250	270
DN 80	230	230	260	280
DN 100	240	260	290	310
DN 150	270	300	330	350
DN 200	320	360	400	420

Table 2-5. Minimum Recommended Stud Bolt Lengths for Wafer Installation with JIS Flanges

Line Size	Minimum Recommended Stud Bolt Lengths (in mm) for Each Flange Rating		
	JIS 10k	JIS 16k and 20k	JIS 40k
15mm	150	155	185
25mm	175	175	190
40mm	195	195	225
50mm	210	215	230
80mm	220	245	265
100mm	235	260	295
150mm	270	290	355
200mm	310	335	410

Wafer-Style Flowmeter Alignment and Mounting

Center the wafer-style meter body inside diameter with respect to the inside diameter of the adjoining upstream and downstream piping. This will ensure that the flowmeter achieves its specified accuracy.

Alignment rings are provided with each wafer-style meter body for centering purposes. Follow these steps to align the meter body for installation. Refer to Figure 2-7 on page 2-11.

1. Place the alignment rings over each end of the meter body.
2. Insert the studs for the bottom side of the meter body between the pipe flanges.
3. Place the meter body (with alignment rings) between the flanges. Make sure that the alignment rings are properly placed onto the studs. Align the studs with the markings on the ring that correspond to the flange you are using. If a spacer is used, see Spacers and Table 2-6 below.

NOTE

Be sure to align the flowmeter so the electronics are accessible, the conduits drain and the flowmeter is not subject to direct heat.

4. Place the remaining studs between the pipe flanges.
5. Tighten the nuts in the sequence shown in Figure 2-9 on page 2-12.
6. Check for leaks at the flanges after tightening the flange bolts.

NOTES

The required bolt load for sealing the gasket joint is affected by several factors, including operating pressure and gasket material, width, and condition. A number of factors also affect the actual bolt load resulting from a measured torque, including condition of bolt threads, friction between the nut head and the flange, and parallelism of the flanges. Due to these application-dependent factors, the required torque for each application may be different. Follow the guidelines outlined in the ASME Pressure Vessel Code (Section VIII, Division 2) for proper bolt tightening.

Make sure the flowmeter is centered between flanges of the same nominal size as the flowmeter.

Spacers

Spacers are available with the Model 8800C to maintain the Model 8800A dimensions. If a spacer is used, it should be downstream of the meter body. The spacer kit comes with an alignment ring for ease of installation. Gaskets should be placed on each side of the spacer.

Table 2-6. Dimensions for Spacers

Line Size	Dimensions inch (mm)
1.5 (40)	0.47 (11.9)
2 (50)	1.17 (29.7)
3 (80)	1.27 (32.3)
4 (100)	0.97 (24.6)

Figure 2-7. Wafer-Style Flowmeter Installation with Alignment Rings

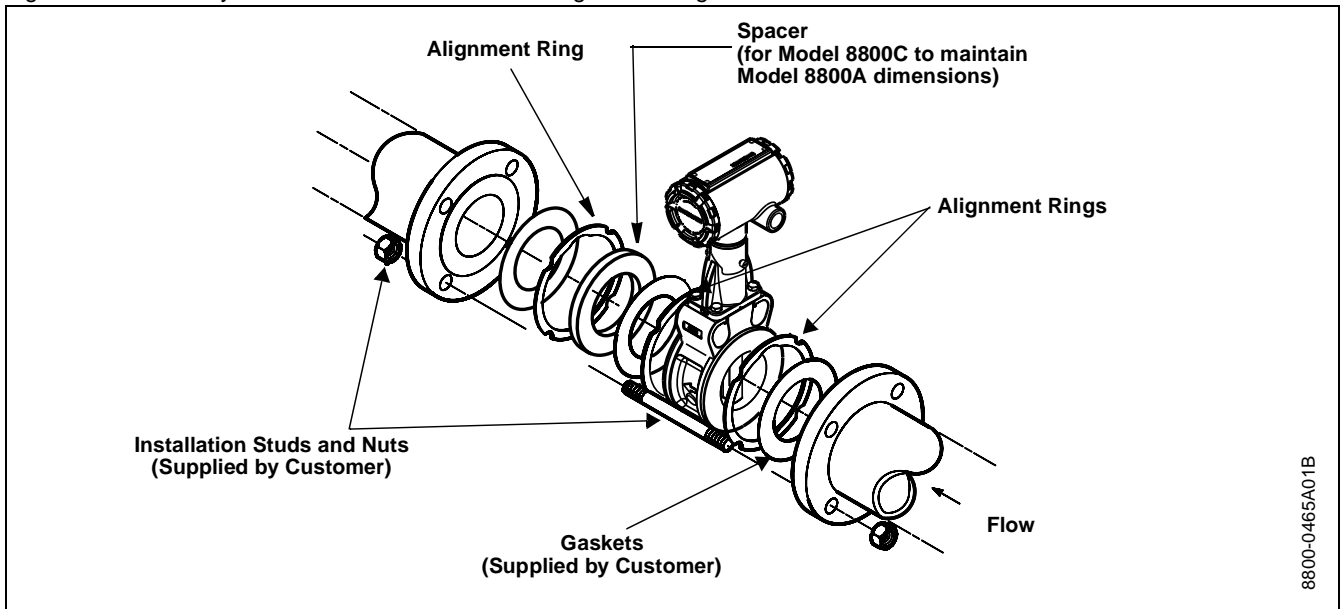
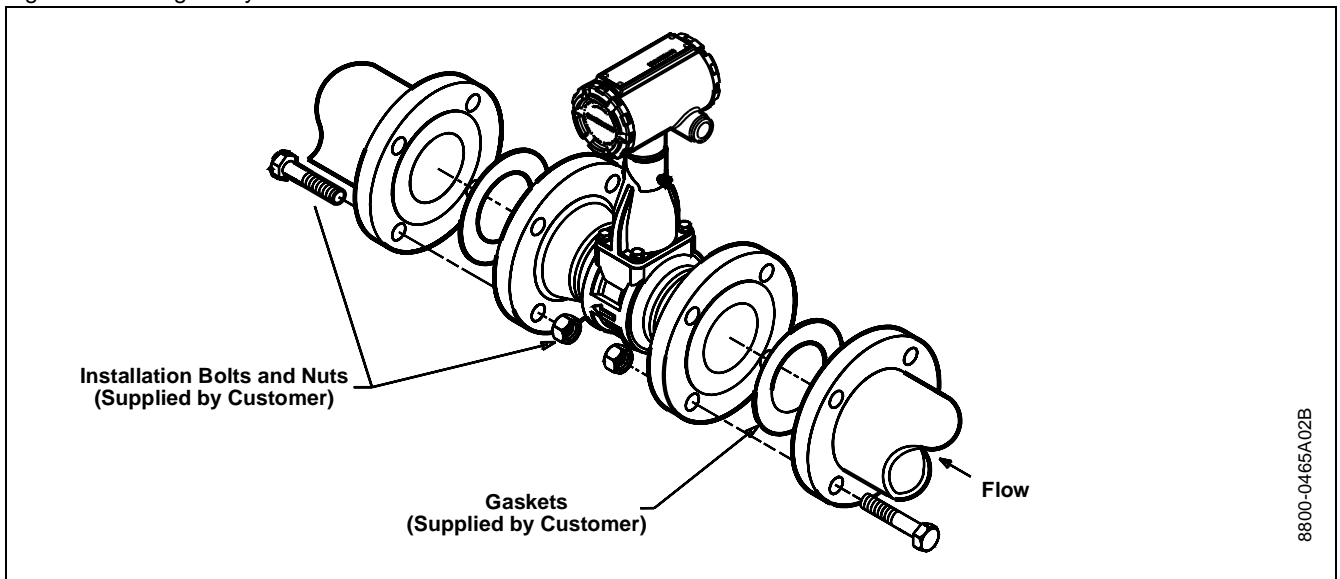

Figure 2-8. Flanged-Style Flowmeter Installation



Flanged-Style Flowmeter Mounting

Physical mounting of a flanged-style flowmeter is similar to installing a typical section of pipe. Conventional tools, equipment, and accessories (such as bolts and gaskets) are required. Tighten the nuts following the sequence shown in Figure 2-9.

NOTE

The required bolt load for sealing the gasket joint is affected by several factors, including operating pressure and gasket material, width, and condition. A number of factors also affect the actual bolt load resulting from a measured torque, including condition of bolt threads, friction between the nut head and the flange, and parallelism of the flanges. Due to these application-dependent factors, the required torque for each application may be different. Follow the guidelines outlined in the ASME Pressure Vessel Code (Section VIII, Division 2) for proper bolt tightening.

Make sure the flowmeter is centered between flanges of the same nominal size as the flowmeter.

Figure 2-9. Flange Bolt Torquing Sequence

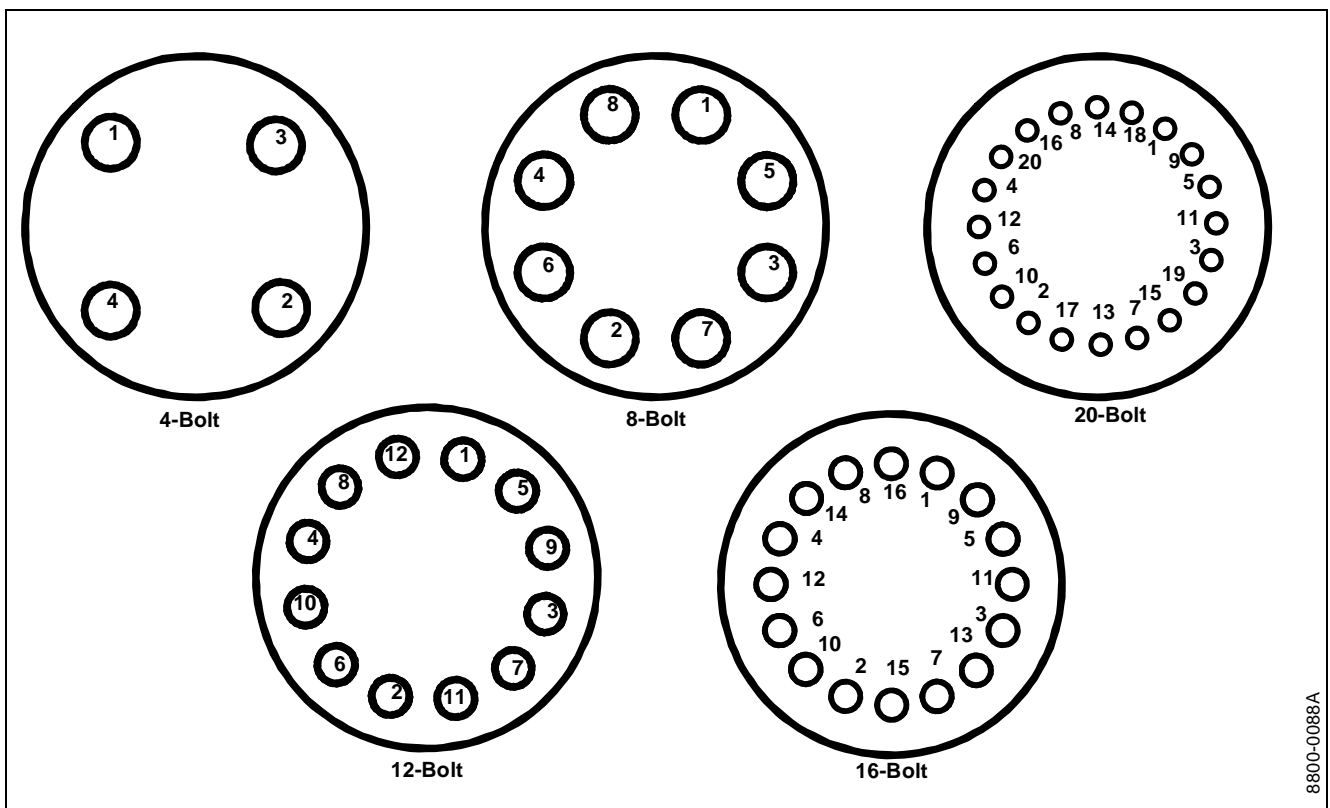

Flowmeter Grounding

Grounding is not required in typical vortex applications; however, a good ground will eliminate possible noise pickup by the electronics. Grounding straps may be used to ensure that the meter is grounded to the process piping. If you are using the transient protection option (T1), grounding straps are required to provide a good low impedance ground.

To use grounding straps, secure one end of the grounding strap to the bolt extending from the side of the meter body and attach the other end of each grounding strap to a suitable ground.

Electronics Considerations

Both integral and remote mounted electronics require input power at the electronics. For remote mount installations, mount the electronics against a flat surface or on a pipe that is up to two inches in diameter. Remote mounting hardware includes a bracket that is polyurethane painted carbon steel and one carbon steel u-bolt. See Figure 2-16 on page 2-24 for dimensional information.

High-Temperature Installations

Install the meter body so the electronics are positioned to the side of or below the pipe as shown in Figure 2-2 on page 2-4. Insulation may be required around the pipe to maintain a temperature below 185 °F (85 °C).

Conduit Connections

The electronics housing has two ports for 1/2–14 NPT conduit connections. Adapters are also available for PG 13.5 or M20×1.5 conduit. These connections are made in a conventional manner in accordance with local or plant electrical codes. Be sure to properly seal unused ports to prevent moisture or other contamination from entering the terminal block compartment of the electronics housing.

NOTE

In some applications it may be necessary to install conduit seals and arrange for conduits to drain to prevent moisture from entering the wiring compartment.

High-Point Installation

Prevent condensation in any conduit from flowing into the housing by mounting the flowmeter at a high point in the conduit run. If the flowmeter is mounted at a low point in the conduit run, the terminal compartment could fill with fluid.

If the conduit originates above the flowmeter, route conduit below the flowmeter before entry. In some cases a drain seal may need to be installed.

Figure 2-10. Proper Conduit Installation with Model 8800C

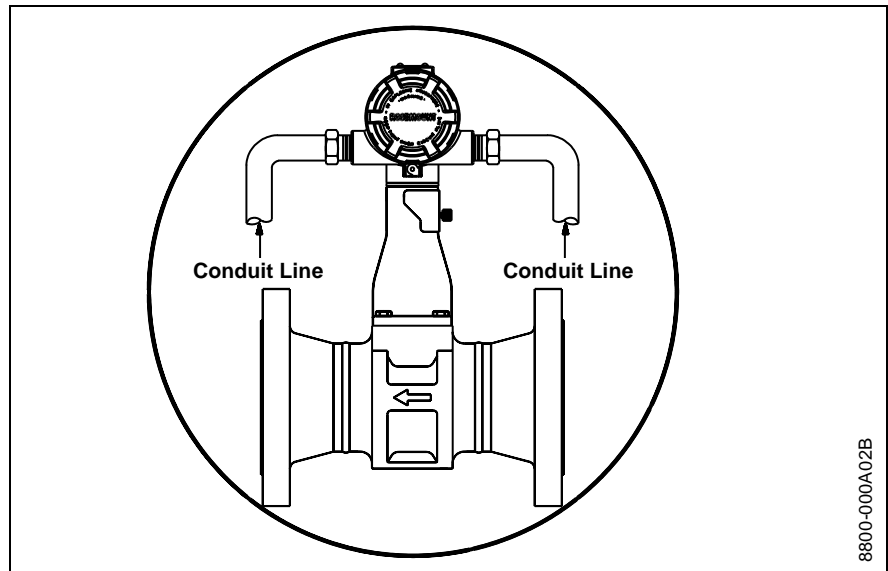

Cable Gland

If you are using cable gland instead of conduit, follow the cable gland manufacturer's instructions for preparation and make the connections in a conventional manner in accordance with local or plant electrical codes. Be sure to properly seal unused ports to prevent moisture or other contamination from entering the terminal block compartment of the electronics housing.

Grounding the Transmitter Case

The transmitter case should always be grounded in accordance with national and local electrical codes. The most effective transmitter case grounding method is direct connection to earth ground with minimal impedance. Methods for grounding the transmitter case include:

- **Internal Ground Connection:** The Internal Ground Connection screw is inside the FIELD TERMINALS side of the electronics housing. This screw is identified by a ground symbol (\oplus), and is standard on all Model 8800C transmitters.
- **External Ground Assembly:** This assembly is included with the optional transient protection terminal block (Option Code T1), and it is included with KEMA/CENELEC Flameproof Certification (Option Code ED), BASEEFA/CENELEC Intrinsic Safety Certification (Option Code I1), and BASEEFA Type N Certification (Option Code N1). The External Ground Assembly can also be ordered with the transmitter (Option Code V5).

NOTE

Grounding the transmitter case using the threaded conduit connection may not provide a sufficient ground. The transient protection terminal block (Option Code T1) does not provide transient protection unless the transmitter case is properly grounded. See Transient Protection on page 2-36 for transient terminal block grounding. Use the above guidelines to ground the transmitter case. Do not run the transient protection ground wire with signal wiring as the ground wire may carry excessive current if a lightning strike occurs.

Figure 2-11. Flanged-Style Flowmeter Dimensional Drawings (1/2- through 12-in./15 through 300 mm Line Sizes)

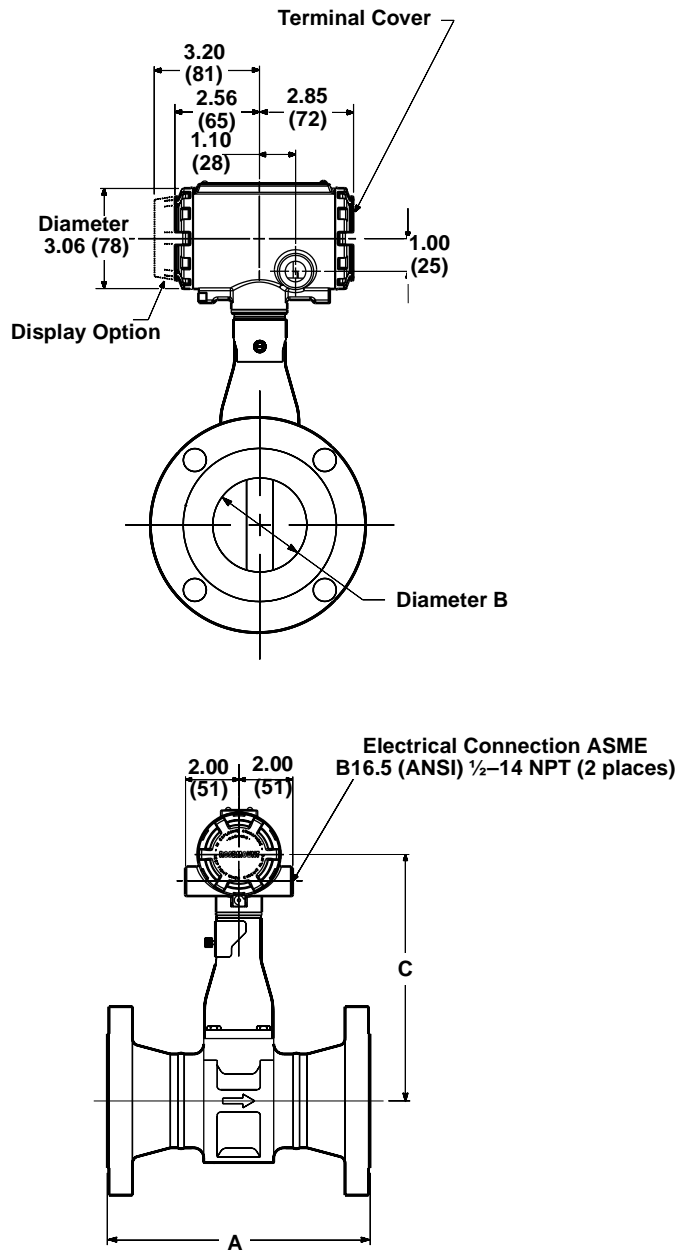

NOTE
Dimensions are in inches (millimeters)

8800-0002A02B, 0002B02B

Rosemount Model 8800C Vortex Flowmeter

Table 2-7. Flanged-Style Flowmeter (1/2-through 3-in./ 15 through 80 mm Line Sizes)

Nominal Size Inch (mm)	Flange Rating	Face-to-face A Inch (mm) ⁽¹⁾	A-ANSI RTJ Inch (mm)	Diameter B Inch (mm) ⁽²⁾	C Inch (mm) ⁽³⁾	Weight ⁽⁴⁾ lb (kg)
½ (15)	Class 150	6.9 (175)	–	0.52 (13,2)	7.6 (193)	9.1 (4,1)
	Class 300	7.2 (183)	7.7 (196)	0.52 (13,2)	7.6 (193)	10.4 (4,7)
	Class 600	7.7 (196)	7.7 (196)	0.52 (13,2)	7.6 (193)	10.8 (4,9)
	PN 16/40	6.1 (155)	–	0.52 (13,2)	7.6 (193)	10.4 (4,7)
	PN 100	6.6 (168)	–	0.52 (13,2)	7.6 (193)	12.3 (5,6)
	JIS 10K/20K	6.3 (160)	–	0.52 (13,2)	7.6 (193)	10.1 (4,5)
	JIS 40K	7.3 (185)	–	0.52 (13,2)	7.6 (193)	13.5 (6,1)
1 (25)	Class 150	7.5 (191)	8.0 (203)	0.95 (24,1)	7.7 (196)	12.3 (5,6)
	Class 300	8.0 (203)	8.5 (216)	0.95 (24,1)	7.7 (196)	15.0 (6,8)
	Class 600	8.5 (216)	8.5 (216)	0.95 (24,1)	7.7 (196)	15.8 (7,2)
	Class 900	9.4 (239)	9.4 (239)	0.95 (24,1)	7.7 (196)	24.3 (11,0)
	PN 16/40	6.3 (160)	–	0.95 (24,1)	7.7 (196)	12.3 (5,6)
	PN 100	7.7 (195)	–	0.95 (24,1)	7.7 (196)	19.5 (8,8)
	PN 160	7.7 (195)	–	0.95 (24,1)	7.7 (196)	19.5 (8,8)
	JIS 10K/20K	6.5 (165)	–	0.95 (24,1)	7.7 (196)	13.7 (6,2)
	JIS 40K	7.9 (200)	–	0.95 (24,1)	7.7 (196)	17.4 (7,9)
1 ½ (40)	Class 150	8.2 (208)	8.7 (221)	1.49 (37,8)	8.1 (206)	17.6 (8,0)
	Class 300	8.7 (221)	9.2 (234)	1.49 (37,8)	8.1 (206)	23.0 (10,4)
	Class 600	9.4 (239)	9.4 (239)	1.49 (37,8)	8.1 (206)	25.3 (11,5)
	Class 900	10.4 (264)	10.4 (264)	1.49 (37,8)	8.1 (206)	36.3 (16,5)
	PN 16/40	6.9 (175)	–	1.49 (37,8)	8.1 (206)	19.3 (8,8)
	PN 100	8.2 (208)	–	1.49 (37,8)	8.1 (206)	27.9 (12,7)
	PN 160	8.4 (213)	–	1.49 (37,8)	8.1 (206)	29.3 (13,3)
	JIS 10K/20K	7.3 (185)	–	1.49 (37,8)	8.1 (206)	18.6 (8,4)
	JIS 40K	8.5 (215)	–	1.49 (37,8)	8.1 (206)	25.6 (11,6)
2 (50)	Class 150	9.3 (236)	9.8 (249)	1.92 (48,8)	8.5 (216)	22.0 (10,0)
	Class 300	9.8 (249)	10.4 (264)	1.92 (48,8)	8.5 (216)	26.0 (11,8)
	Class 600	10.5 (267)	10.7 (271)	1.92 (48,8)	8.5 (216)	29.6 (13,4)
	Class 900	12.8 (325)	12.9 (328)	1.92 (48,8)	8.5 (216)	59.4 (26,9)
	PN 16/40	8.0 (203)	–	1.92 (48,8)	8.5 (216)	23.0 (10,4)
	PN 64	9.2 (234)	–	1.92 (48,8)	8.5 (216)	30.6 (13,9)
	PN 100	9.6 (244)	–	1.92 (48,8)	8.5 (216)	36.4 (16,5)
	PN 160	10.2 (259)	–	1.92 (48,8)	8.5 (216)	38.7 (17,6)
	JIS 10K	7.7 (195)	–	1.92 (48,8)	8.5 (216)	19.5 (8,8)
	JIS 20K	8.3 (210)	–	1.92 (48,8)	8.5 (216)	20.1 (9,1)
	JIS 40K	9.8 (249)	–	1.92 (48,8)	8.5 (216)	28.3 (12,8)
	3 (80)	Class 150	9.9 (251)	10.4 (264)	2.87 (72,9)	9.1 (231)
Class 300		10.6 (269)	11.2 (284)	2.87 (72,9)	9.1 (231)	46.1 (20,9)
Class 600		11.4 (290)	11.5 (292)	2.87 (72,9)	9.1 (231)	52.1 (26,6)
Class 900		12.9 (328)	13.0 (330)	2.87 (72,9)	9.1 (231)	75.5 (34,2)
PN 16/40		8.9 (226)	–	2.87 (72,9)	9.1 (231)	36.3 (16,5)
PN 64		10.0 (254)	–	2.87 (72,9)	9.1 (231)	45.1 (20,5)
PN 100		10.5 (267)	–	2.87 (72,9)	9.1 (231)	54.4 (24,7)
PN 160		11.2 (284)	–	2.87 (72,9)	9.1 (231)	59.6 (27,0)
JIS 10K		7.9 (200)	–	2.87 (72,9)	9.1 (231)	27.6 (12,5)
JIS 20K		9.3 (235)	–	2.87 (72,9)	9.1 (231)	35.0 (15,9)
JIS 40K		11.0 (280)	–	2.87 (72,9)	9.1 (231)	50.0 (22,7)

(1) ±0.14 inch (3.6 mm)

(2) ±0.03 inch (0.8 mm)

(3) ±0.20 inch (5.1 mm)

(4) Add 0.2 lb (0,1 kg) for display option.

Table 2-8. Flanged-Style Flowmeter (4-through 12-in./ 100 through 300mm Line Sizes) (Refer to Figure 2-11)

Nominal Size Inch (mm)	Flange Rating	Face-to-face A Inch (mm) ⁽¹⁾	A ANSI RTJ Inch (mm)	Diameter B Inch (mm) ⁽²⁾	C Inch (mm) ⁽³⁾	Weight ⁽⁴⁾ lb (kg)	
4 (100)	Class 150	10.3 (262)	10.8 (274)	3.79 (96,3)	9.6 (244)	50.7 (23,0)	
	Class 300	11.0 (279)	11.6 (295)	3.79 (96,3)	9.6 (244)	70.8 (32,1)	
	Class 600	12.8 (325)	12.9 (328)	3.79 (96,3)	9.6 (244)	96.5 (43,8)	
	Class 900	13.8 (351)	13.9 (353)	3.79 (96,3)	9.6 (244)	119.7 (54,3)	
	PN 16	8.4 (213)	–	3.79 (96,3)	9.6 (244)	40.1 (18,2)	
	PN 40	9.4 (239)	–	3.79 (96,3)	9.6 (244)	49.2 (22,3)	
	PN 64	10.4 (264)	–	3.79 (96,3)	9.6 (244)	62.1 (28,2)	
	PN 100	11.3 (287)	–	3.79 (96,3)	9.6 (244)	78.5 (35,6)	
	PN 160	12.1 (307)	–	3.79 (96,3)	9.6 (244)	85.8 (38,9)	
	JIS 10K	8.7 (220)	–	3.79 (96,3)	9.6 (244)	37.0 (16,8)	
	JIS 20K	8.7 (220)	–	3.79 (96,3)	9.6 (244)	44.9 (20,4)	
	JIS 40K	11.8 (300)	–	3.79 (96,3)	9.6 (244)	75.3 (34,2)	
	6 (150)	Class 150	11.6 (295)	12.1 (307)	5.7 (144,8)	10.8 (274)	90.0 (40,8)
		Class 300	12.4 (315)	13.0 (330)	5.7 (144,8)	10.8 (274)	129.5 (58,7)
Class 600		14.3 (363)	14.5 (368)	5.7 (144,8)	10.8 (274)	195.5 (88,7)	
PN 16		8.9 (226)	–	5.7 (144,8)	10.8 (274)	75.6 (34,3)	
PN 40		10.5 (267)	–	5.7 (144,8)	10.8 (274)	95.3 (43,2)	
PN 64		12.1 (307)	–	5.7 (144,8)	10.8 (274)	138.8 (63,0)	
PN 100		13.7 (348)	–	5.7 (144,8)	10.8 (274)	168.5 (76,4)	
JIS 10K		10.6 (270)	–	5.7 (144,8)	10.8 (274)	79.8 (36,2)	
JIS 20K		10.6 (270)	–	5.7 (144,8)	10.8 (274)	97.7 (44,3)	
JIS 40K		14.2 (360)	–	5.7 (144,8)	10.8 (274)	175.9 (79,8)	
8 (200)	Class 150	13.6 (345)	14.1 (358)	7.55 (191,8)	11.7 (297)	139.6 (63,3)	
	Class 300	14.3 (363)	15.0 (381)	7.55 (191,8)	11.7 (297)	196.2 (89,0)	
	Class 600	16.6 (422)	16.7 (424)	7.55 (191,8)	11.7 (297)	295.0 (133,8)	
	PN 10	10.5 (266)	–	7.55 (191,8)	11.7 (297)	109.6 (49,7)	
	PN 16	10.5 (266)	–	7.55 (191,8)	11.7 (297)	108.5 (49,2)	
	PN 25	11.9 (302)	–	7.55 (191,8)	11.7 (297)	136.3 (61,8)	
	PN 40	12.5 (318)	–	7.55 (191,8)	11.7 (297)	154.8 (70,2)	
	PN 64	14.2 (361)	–	7.55 (191,8)	11.7 (297)	214.6 (97,3)	
	PN 100	15.8 (401)	–	7.55 (191,8)	11.7 (297)	279.9 (127)	
	JIS 10K	12.2 (310)	–	7.55 (191,8)	11.7 (297)	109.9 (49,9)	
	JIS 20K	12.2 (310)	–	7.55 (191,8)	11.7 (297)	134.3 (60,9)	
	JIS 40K	16.5 (420)	–	7.55 (191,8)	11.7 (297)	255.7 (116)	
	10 (250)	Class 150	14.6 (371)	15.1 (384)	9.56 (243)	12.8 (325)	197.2 (89)
		Class 300	15.8 (401)	16.4 (417)	9.56 (243)	12.8 (325)	285.2 (129)
Class 600		19.1 (485)	19.2 (488)	9.56 (243)	12.8 (325)	475.3 (216)	
PN 10		11.9 (302)	–	9.56 (243)	12.8 (325)	156.3 (71)	
PN 16		12.1 (307)	–	9.56 (243)	12.8 (325)	161.1 (73)	
PN 25		13.5 (343)	–	9.56 (243)	12.8 (325)	197.4 (90)	
PN 40		14.8 (376)	–	9.56 (243)	12.8 (325)	245.3 (111)	
PN 64		16.4 (417)	–	9.56 (243)	12.8 (325)	306.3 (139)	
PN 100		18.9 (480)	–	9.56 (243)	12.8 (325)	443.0 (201)	
JIS 10K		14.6 (371)	–	9.56 (243)	12.8 (325)	173.3 (79)	
JIS 20K		14.6 (371)	–	9.56 (243)	12.8 (325)	220.5 (100)	
JIS 40K		18.1 (460)	–	9.56 (243)	12.8 (325)	377.3 (171)	
12 (300)		Class 150	16.8 (427)	17.3 (439)	11.38 (289)	13.7 (348)	296.0 (134)
		Class 300	18.0 (457)	18.7 (475)	11.38 (289)	13.7 (348)	413.2 (187)
	Class 600	20.5 (521)	20.7 (526)	11.38 (289)	13.7 (348)	592.2 (269)	
	PN 10	13.2 (335)	–	11.38 (289)	13.7 (348)	203.1 (92)	
	PN 16	13.9 (353)	–	11.38 (289)	13.7 (348)	223.4 (101)	
	PN 25	15.0 (381)	–	11.38 (289)	13.7 (348)	267.8 (121)	
	PN 40	16.9 (429)	–	11.38 (289)	13.7 (348)	345.7 (157)	
	PN 64	18.8 (478)	–	11.38 (289)	13.7 (348)	428.5 (194)	
	PN 100	21.2 (538)	–	11.38 (289)	13.7 (348)	640.8 (291)	
	JIS 10K	15.7 (399)	–	11.38 (289)	13.7 (348)	224.5 (102)	
	JIS 20K	15.7 (399)	–	11.38 (289)	13.7 (348)	287.1 (130)	
	JIS 40K	19.7 (500)	–	11.38 (289)	13.7 (348)	504.7 (229)	

(1) ±0.14 inch (3.6 mm)

(2) ±0.03 inch (0.8 mm)

(3) ±0.20 inch (5.1 mm)

(4) Add 0.2 lb (0,1 kg) for display option.

Rosemount Model 8800C Vortex Flowmeter

Figure 2-12. Wafer-Style Dimensional Drawings (1/2-through 1 1/2 in./15 through 40 mm Line Sizes)

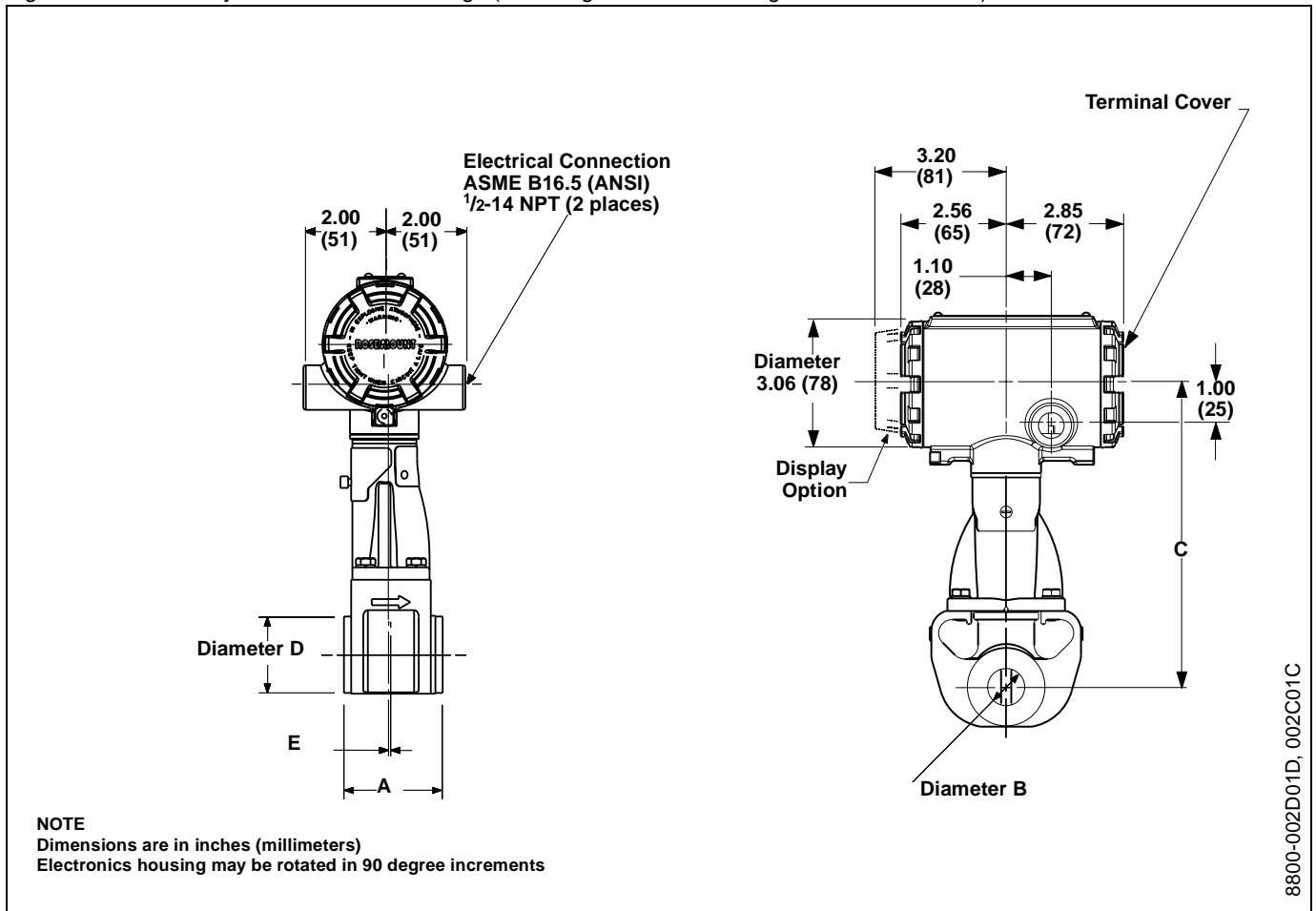

Table 2-9. Model 8800C Stainless Steel Wafer

Nominal Size Inch (mm)	Face-to-face A Inch (mm) ⁽¹⁾	Diameter B Inch (mm) ⁽²⁾	C Inch (mm) ⁽³⁾	Diameter D Inch (mm)	E Inch (mm)	Weight lb (kg) ⁽⁴⁾
1/2 (15)	2.56 (65)	0.54 (13,7)	7.63 (194)	1.38 (35,1)	0.23 (5,9)	7.3 (3,3)
1 (25)	2.56 (65)	0.95 (24,1)	7.74 (197)	1.98 (50,3)	0.23 (5,9)	7.4 (3,4)
1 1/2 (40)	2.56 (65)	1.49 (37,8)	8.14 (207)	2.87 (72,9)	0.18 (4,6)	10.0 (4,5)

(1) ±0.14 inch (3.6 mm)

(2) ±0.03 inch (0.8 mm)

(3) ±0.20 inch (5.1 mm)

(4) Add 0.2 lb (0,1 kg) for display option.

Table 2-10. Model 8800A Hastelloy® Wafer

Nominal Size Inch (mm)	Face-to-face A Inch (mm) ⁽¹⁾	Diameter B Inch (mm) ⁽²⁾	C Inch (mm) ⁽³⁾	Diameter D Inch (mm)	E Inch (mm)	Weight lb (kg) ⁽⁴⁾
1/2 (15)	2.44 (62)	0.52 (13,2)	7.63 (194)	1.38 (35,1)	0.17 (4,3)	6.8 (3,1)
1 (25)	2.44 (62)	0.95 (24,1)	7.74 (197)	1.98 (50,3)	0.17 (4,3)	7.6 (3,4)
1 1/2 (40)	3.11 (79)	1.49 (37,8)	8.08 (205)	2.87 (72,9)	0.47 (11,9)	10.8 (4,9)

(1) ±0.14 inch (3.6 mm)

(2) ±0.03 inch (0.8 mm)

(3) ±0.20 inch (5.1 mm)

(4) Add 0.2 lb (0,1 kg) for display option.

Figure 2-13. Wafer-Style Dimensional Drawings (2-through 8-in./50 through 200 mm Line Sizes)

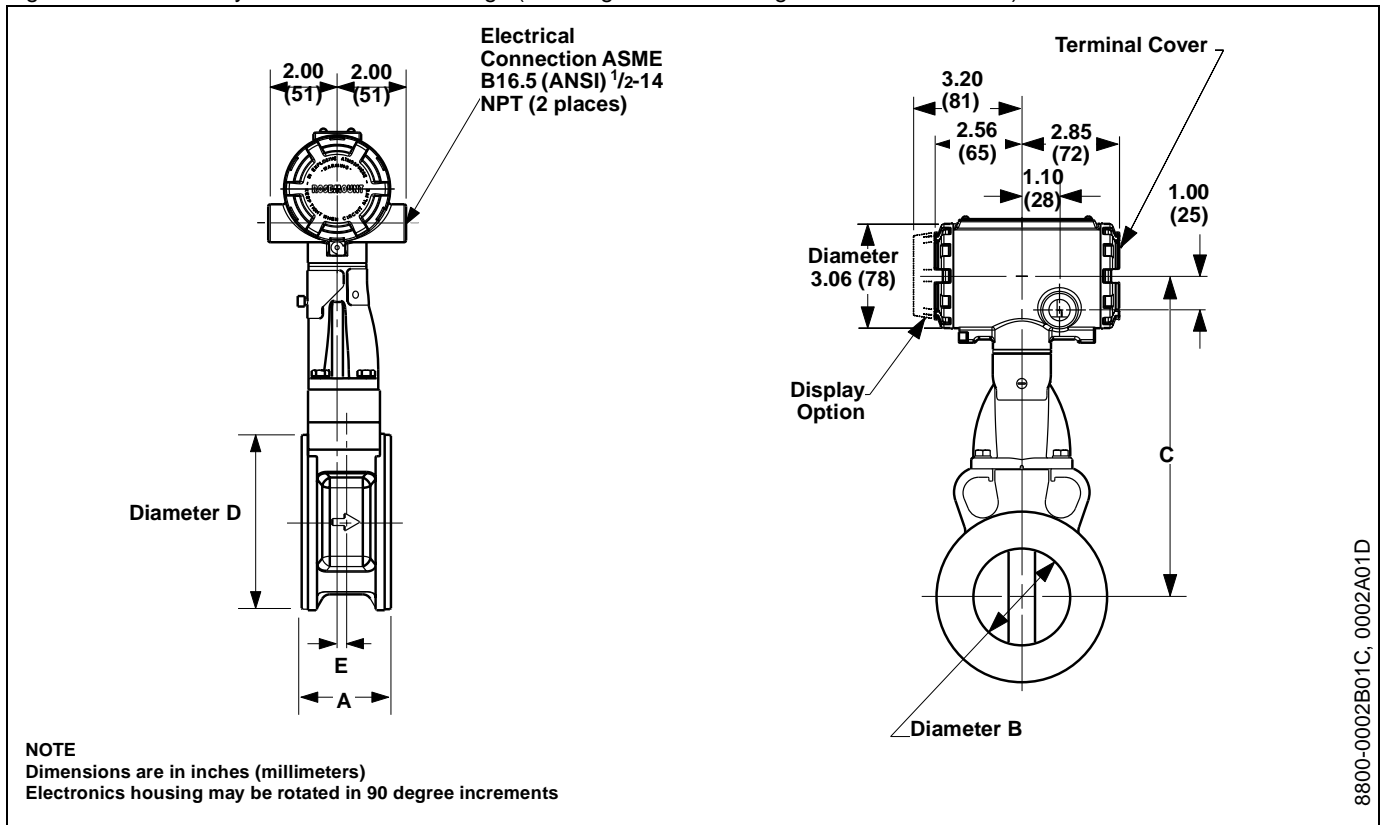

Table 2-11. Model 8800C Stainless Steel Wafer

Nominal Size Inch (mm)	Face-to-face A Inch (mm) ⁽¹⁾	Diameter B Inch (mm) ⁽²⁾	C Inch (mm) ⁽³⁾	Diameter D Inch (mm)	E Inch (mm)	Weight lb (kg) ⁽⁴⁾
2 (50)	2.56 (65)	1.92 (49)	8.85 (225)	3.86 (98)	0.12 (3)	10.6 (4,8)
3 (80)	2.56 (65)	2.87 (73)	9.62 (244)	5.00 (127)	0.25 (6)	13.6 (6,2)
4 (100)	3.42 (87)	3.79 (96)	10.48 (266)	6.20 (158)	0.44 (11)	21.4 (9,7)
6 (150)	4.99 (127)	5.70 (145)	10.75 (273)	8.50 (216)	1.11 (28)	49.1 (22,3)
8 (200)	6.60 (168)	7.55 (192)	11.67 (296)	10.62 (270)	0.89 (23)	85 (38,6)

- (1) ±0.14 inch (3.6 mm)
- (2) ±0.03 inch (0.8 mm)
- (3) ±0.20 inch (5.1 mm)
- (4) Add 0.2 lb (0,1 kg) for display option.

Table 2-12. Model 8800A Hastelloy® Wafer

Nominal Size Inch (mm)	Face-to-face A Inch (mm) ⁽¹⁾	Diameter B Inch (mm) ⁽²⁾	C Inch (mm) ⁽³⁾	Diameter D Inch (mm)	E Inch (mm)	Weight lb (kg) ⁽⁴⁾
2 (50)	3.81 (97)	1.92 (49)	8.45 (215)	3.86 (98)	0.86 (22)	10.8 (4,9)
3 (80)	3.92 (100)	2.87 (73)	9.10 (231)	5.00 (127)	0.76 (19)	15.0 (6,8)
4 (100)	4.47 (114)	3.79 (96)	9.56 (243)	6.20 (158)	0.82 (21)	23.0 (10,4)
6 (150)	4.99 (127)	5.70 (145)	10.75 (273)	8.50 (216)	1.11 (28)	49.1 (22,3)
8 (200)	6.60 (168)	7.55 (192)	11.67 (296)	10.62 (270)	0.89 (23)	85 (38,6)

- (1) ±0.14 inch (3.6 mm)
- (2) ±0.03 inch (0.8 mm)
- (3) ±0.20 inch (5.1 mm)
- (4) Add 0.2 lb (0,1 kg) for display option.

Rosemount Model 8800C Vortex Flowmeter

Figure 2-14. Vortex Dual-Sensor Style Flowmeter Dimensional Drawings (1/2-through 8-in./15 through 200 mm Line Sizes)

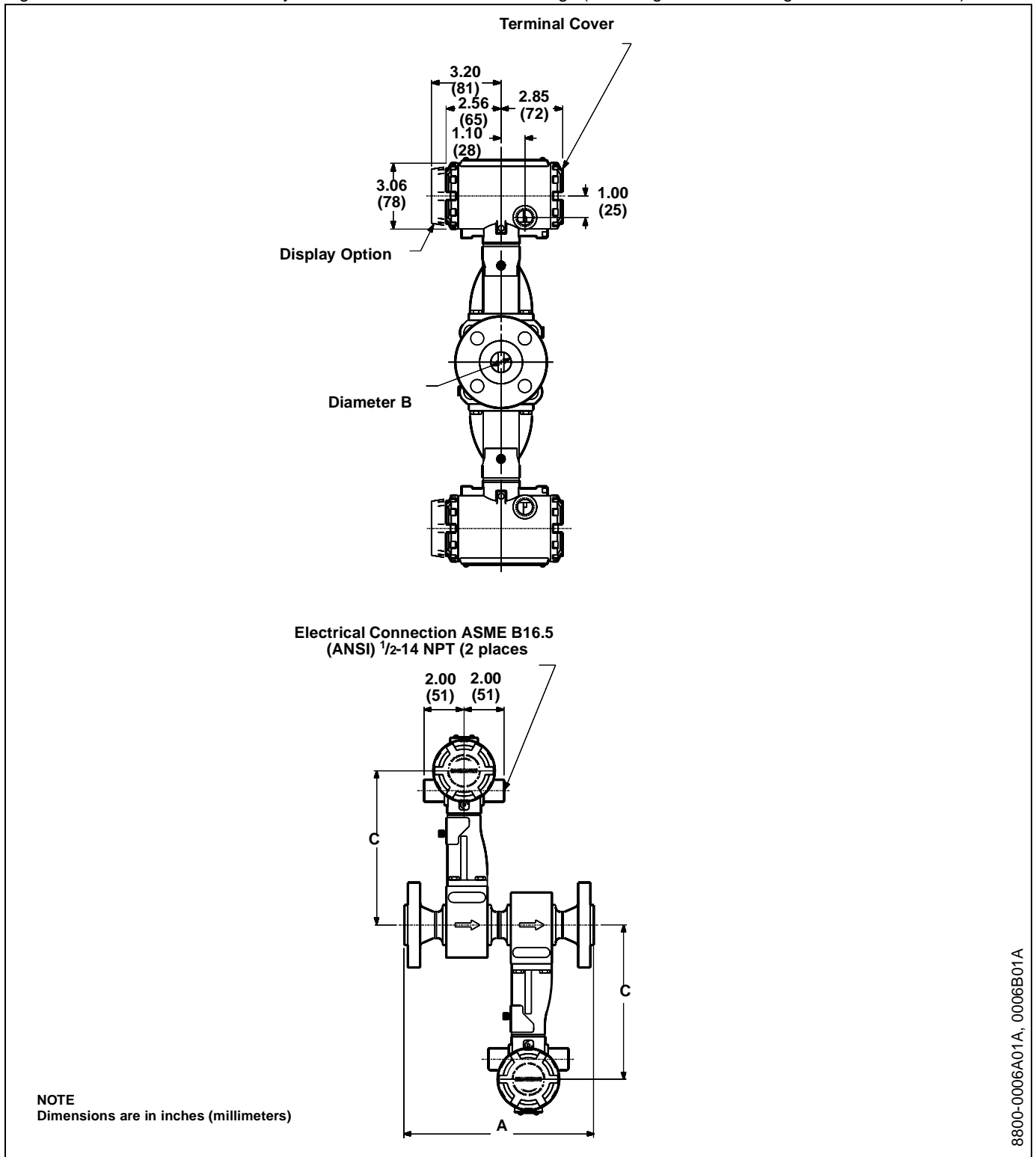
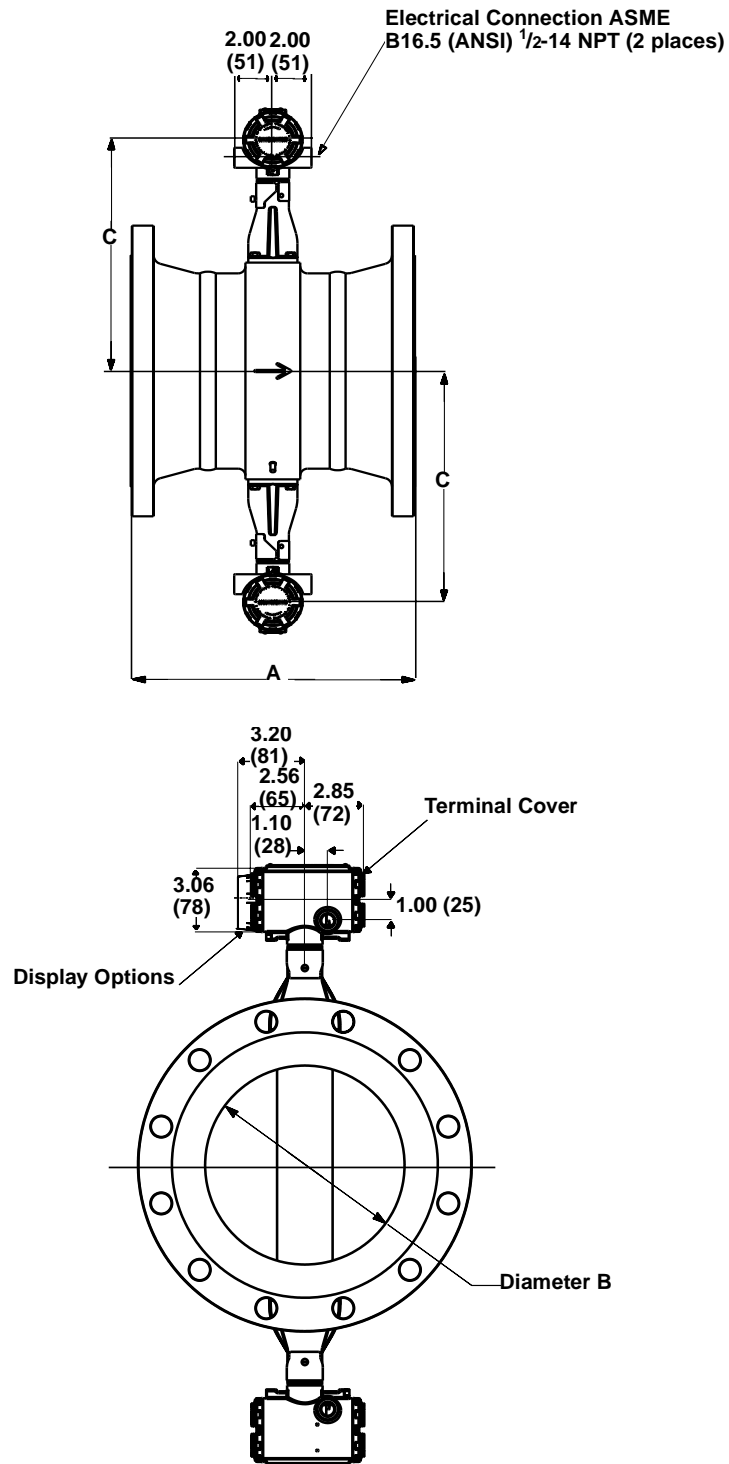

Figure 2-15. Vortex Dual-Sensor Style Flowmeter Dimensional Drawings (10-through 12-in./250 through 300 mm Line Sizes)



NOTE
Dimensions are in inches (millimeters)

8800-8800c_01, 8800c_02

Rosemount Model 8800C Vortex Flowmeter

Table 2-13. Vortex Dual-Sensor Style Flowmeter (1/2-through 3-in./15 through 80 mm Line Sizes)

Nominal Size Inch (mm)	Flange Rating	Face-to-face	A	Diameter		Weight lb (kg) ⁽⁴⁾
		A	ANSI RTJ	B	C	
		Inch (mm) ⁽¹⁾	Inch (mm)	Inch (mm) ⁽²⁾	Inch (mm) ⁽³⁾	
1/2 (15)	Class 150	12.0 (305)	–	0.52 (13,2)	7.6 (193)	16.2 (7,4)
	Class 300	12.3 (312)	12.8 (325)	0.52 (13,2)	7.6 (193)	17.4 (7,9)
	Class 600	12.8 (325)	12.8 (325)	0.52 (13,2)	7.6 (193)	17.9 (8,1)
	PN 16/40	11.2 (284)	–	0.52 (13,2)	7.6 (193)	17.2 (7,8)
	PN 100	11.8 (300)	–	0.52 (13,2)	7.6 (193)	19.2 (8,7)
	JIS 10K/20K	11.4 (290)	–	0.52 (13,2)	7.6 (193)	17.1 (7,8)
	JIS 40K	12.4 (315)	–	0.52 (13,2)	7.6 (193)	20.6 (9,3)
	1 (25)	Class 150	15.1 (384)	15.6 (396)	0.95 (24,1)	7.7 (196)
Class 300		15.6 (396)	16.1 (409)	0.95 (24,1)	7.7 (196)	22.5 (10,2)
Class 600		16.1 (409)	16.1 (409)	0.95 (24,1)	7.7 (196)	23.3 (10,6)
Class 900		17.0 (432)	17.0 (432)	0.95 (24,1)	7.7 (196)	31.8 (14,4)
PN 16/40		13.9 (353)	–	0.95 (24,1)	7.7 (196)	21.0 (9,5)
PN 100		15.3 (389)	–	0.95 (24,1)	7.7 (196)	27.0 (12,3)
PN 160		15.3 (389)	–	0.95 (24,1)	7.7 (196)	27.0 (12,3)
JIS 10K/20K		14.1 (358)	–	0.95 (24,1)	7.7 (196)	22.1 (10,0)
JIS 40K		15.5 (394)	–	0.95 (24,1)	7.7 (196)	25.8 (11,7)
1 1/2 (40)		Class 150	11.3 (287)	11.8 (300)	1.49 (37,8)	8.1 (206)
	Class 300	11.8 (300)	12.3 (312)	1.49 (37,8)	8.1 (206)	32.4 (14,7)
	Class 600	12.5 (318)	12.5 (318)	1.49 (37,8)	8.1 (206)	34.8 (15,8)
	Class 900	13.5 (343)	13.5 (343)	1.49 (37,8)	8.1 (206)	45.7 (20,7)
	PN 16/40	10.0 (254)	–	1.49 (37,8)	8.1 (206)	28.7 (13,0)
	PN 100	11.3 (287)	–	1.49 (37,8)	8.1 (206)	37.4 (17,0)
	PN 160	11.5 (292)	–	1.49 (37,8)	8.1 (206)	38.8 (17,6)
	JIS 10K/20K	10.4 (264)	–	1.49 (37,8)	8.1 (206)	27.9 (12,6)
	JIS 40K	11.5 (292)	–	1.49 (37,8)	8.1 (206)	34.9 (15,8)
	2 (50)	Class 150	13.0 (330)	13.6 (345)	1.92 (48,8)	8.5 (216)
Class 300		13.6 (345)	14.1 (358)	1.92 (48,8)	8.5 (216)	35.9 (16,3)
Class 600		14.3 (363)	14.3 (363)	1.92 (48,8)	8.5 (216)	39.5 (17,9)
Class 900		16.6 (422)	16.7 (424)	1.92 (48,8)	8.5 (216)	69.2 (31,4)
PN 16/40		11.8 (300)	–	1.92 (48,8)	8.5 (216)	32.9 (14,9)
PN 64		12.9 (328)	–	1.92 (48,8)	8.5 (216)	40.5 (18,4)
PN 100		13.4 (340)	–	1.92 (48,8)	8.5 (216)	46.2 (21,0)
PN 160		14.0 (356)	–	1.92 (48,8)	8.5 (216)	48.5 (22,0)
JIS 10K		11.5 (292)	–	1.92 (48,8)	8.5 (216)	29.1 (13,2)
JIS 20K		12.1 (307)	–	1.92 (48,8)	8.5 (216)	29.7 (13,5)
JIS 40K		13.6 (345)	–	1.92 (48,8)	8.5 (216)	37.9 (17,2)
3 (80)		Class 150	14.3 (363)	14.8 (376)	2.87 (72,9)	9.1 (231)
	Class 300	15.0 (381)	15.7 (399)	2.87 (72,9)	9.1 (231)	59.5 (27,0)
	Class 600	15.8 (401)	15.8 (401)	2.87 (72,9)	9.1 (231)	65.5 (29,7)
	Class 900	17.3 (439)	17.4 (442)	2.87 (72,9)	9.1 (231)	88.9 (40,3)
	PN 16/40	13.4 (340)	–	2.87 (72,9)	9.1 (231)	49.7 (22,5)
	PN 64	14.5 (367)	–	2.87 (72,9)	9.1 (231)	58.5 (26,5)
	PN 100	14.9 (378)	–	2.87 (72,9)	9.1 (231)	67.8 (30,8)
	PN 160	15.6 (396)	–	2.87 (72,9)	9.1 (231)	73.0 (33,1)
	JIS 10K	12.3 (312)	–	2.87 (72,9)	9.1 (231)	41.0 (18,6)
	JIS 20K	13.7 (348)	–	2.87 (72,9)	9.1 (231)	48.4 (22,0)
	JIS 40K	15.5 (394)	–	2.87 (72,9)	9.1 (231)	63.4 (28,8)

(1) ±0.14 inch (3.6 mm)

(2) ±0.03 inch (0.8 mm)

(3) ±0.20 inch (5.1 mm)

(4) Add 0.4 lb (0,2 kg) for display option.

Table 2-14. Vortex Dual-Sensor Style Flowmeter (4- through 12-in./100 through 300 mm Line Sizes)

Nominal Size Inch (mm)	Flange Rating	Face-to-face A Inch (mm) ⁽¹⁾	A ANSI RTJ Inch (mm)	Diameter B Inch (mm) ⁽²⁾	C Inch (mm) ⁽³⁾	Weight lb (kg) ⁽⁴⁾
4 (100)	Class 150	15.2 (386)	15.7 (399)	3.79 (96,3)	9.6 (244)	68.1 (30,9)
	Class 300	16.0 (406)	16.6 (422)	3.79 (96,3)	9.6 (244)	88.2 (40,0)
	Class 600	17.7 (450)	17.7 (450)	3.79 (96,3)	9.6 (244)	113.9 (51,7)
	Class 900	18.7 (475)	18.9 (480)	3.79 (96,3)	9.6 (244)	137.1 (62,2)
	PN 16	13.3 (338)	–	3.79 (96,3)	9.6 (244)	57.6 (26,1)
	PN 40	14.4 (366)	–	3.79 (96,3)	9.6 (244)	66.6 (30,2)
	PN 64	15.4 (391)	–	3.79 (96,3)	9.6 (244)	79.6 (36,1)
	PN 100	16.3 (414)	–	3.79 (96,3)	9.6 (244)	95.9 (43,5)
	PN 160	17.1 (434)	–	3.79 (96,3)	9.6 (244)	103.2 (46,8)
	JIS 10K	13.6 (345)	–	3.79 (96,3)	9.6 (244)	55.4 (25,1)
	JIS 20K	13.6 (345)	–	3.79 (96,3)	9.6 (244)	63.2 (28,7)
	JIS 40K	16.8 (427)	–	3.79 (96,3)	9.6 (244)	93.7 (42,5)
	6 (150)	Class 150	19.4 (493)	19.9 (505)	5.7 (144,8)	10.8 (274)
Class 300		20.2 (513)	20.8 (528)	5.7 (144,8)	10.8 (274)	165.9 (75,3)
Class 600		22.2 (564)	22.3 (566)	5.7 (144,8)	10.8 (274)	231.9 (105,2)
PN 16		16.8 (427)	–	5.7 (144,8)	10.8 (274)	112.0 (50,8)
PN 40		18.3 (465)	–	5.7 (144,8)	10.8 (274)	131.7 (59,7)
PN 64		19.9 (505)	–	5.7 (144,8)	10.8 (274)	175.2 (79,5)
PN 100		21.5 (546)	–	5.7 (144,8)	10.8 (274)	204.8 (92,9)
JIS 10K		18.5 (470)	–	5.7 (144,8)	10.8 (274)	124.0 (56,2)
JIS 20K		18.5 (470)	–	5.7 (144,8)	10.8 (274)	141.9 (64,4)
JIS 40K		22.0 (559)	–	5.7 (144,8)	10.8 (274)	220.1 (99,8)
8 (200)	Class 150	24.0 (610)	24.5 (622)	7.55 (191,8)	11.7 (297)	190.1 (86,2)
	Class 300	24.8 (630)	25.4 (645)	7.55 (191,8)	11.7 (297)	246.7 (111,9)
	Class 600	27.0 (686)	27.1 (688)	7.55 (191,8)	11.7 (297)	345.5 (156,7)
	PN 10	20.9 (531)	–	7.55 (191,8)	11.7 (297)	160.2 (72,7)
	PN 16	20.9 (531)	–	7.55 (191,8)	11.7 (297)	159.0 (72,1)
	PN 25	22.3 (566)	–	7.55 (191,8)	11.7 (297)	186.9 (83,4)
	PN 40	22.9 (582)	–	7.55 (191,8)	11.7 (297)	205.4 (93,2)
	PN 64	24.7 (627)	–	7.55 (191,8)	11.7 (297)	265.1 (120,2)
	PN 100	26.3 (668)	–	7.55 (191,8)	11.7 (297)	330.4 (149,9)
	JIS 10K	22.6 (574)	–	7.55 (191,8)	11.7 (297)	178.2 (80,8)
	JIS 20K	22.6 (574)	–	7.55 (191,8)	11.7 (297)	202.6 (91,9)
	JIS 40K	27.0 (686)	–	7.55 (191,8)	11.7 (297)	324.0 (147,0)
	10 (250)	Class 150	14.6 (371)	15.1 (384)	9.56 (243)	12.8 (325)
Class 300		15.8 (401)	16.4 (417)	9.56 (243)	12.8 (325)	289.5 (131)
Class 600		19.1 (485)	19.2 (488)	9.56 (243)	12.8 (325)	479.6 (218)
PN 10		11.9 (302)	–	9.56 (243)	12.8 (325)	160.6 (73)
PN 16		12.1 (307)	–	9.56 (243)	12.8 (325)	165.4 (75)
PN 25		13.5 (343)	–	9.56 (243)	12.8 (325)	210.7 (96)
PN 40		14.8 (376)	–	9.56 (243)	12.8 (325)	249.6 (113)
PN 64		16.4 (417)	–	9.56 (243)	12.8 (325)	310.6 (141)
PN 100		18.9 (480)	–	9.56 (243)	12.8 (325)	447.3 (203)
JIS 10K		14.6 (371)	–	9.56 (243)	12.8 (325)	177.6 (81)
JIS 20K		14.6 (371)	–	9.56 (243)	12.8 (325)	224.8 (102)
JIS 40K		18.1 (460)	–	9.56 (243)	12.8 (325)	381.6 (173)
12 (300)		Class 150	16.8 (427)	17.3 (439)	11.38 (289)	13.7 (348)
	Class 300	18.0 (457)	18.7 (475)	11.38 (289)	13.7 (348)	417.5 (189)
	Class 600	20.5 (521)	20.7 (526)	11.38 (289)	13.7 (348)	596.5 (271)
	PN 10	13.2 (335)	–	11.38 (289)	13.7 (348)	207.4 (94)
	PN 16	13.9 (353)	–	11.38 (289)	13.7 (348)	227.7 (103)
	PN 25	15.0 (381)	–	11.38 (289)	13.7 (348)	272.1 (123)
	PN 40	16.9 (429)	–	11.38 (289)	13.7 (348)	350.0 (159)
	PN 64	18.8 (478)	–	11.38 (289)	13.7 (348)	432.8 (196)
	PN 100	21.2 (538)	–	11.38 (289)	13.7 (348)	645.1 (293)
	JIS 10K	15.7 (399)	–	11.38 (289)	13.7 (348)	228.8 (104)
	JIS 20K	15.7 (399)	–	11.38 (289)	13.7 (348)	291.4 (132)
	JIS 40K	19.7 (500)	–	11.38 (289)	13.7 (348)	508.9 (231)

(1) ±0.14 inch (3.6 mm)

(2) ±0.03 inch (0.8 mm)

(3) ±0.20 inch (5.1 mm)

(4) Add 0.4 Lb (0,2 kg) for display option.

Rosemount Model 8800C Vortex Flowmeter

Figure 2-16. Dimensional Drawings for Remote Mount Transmitters

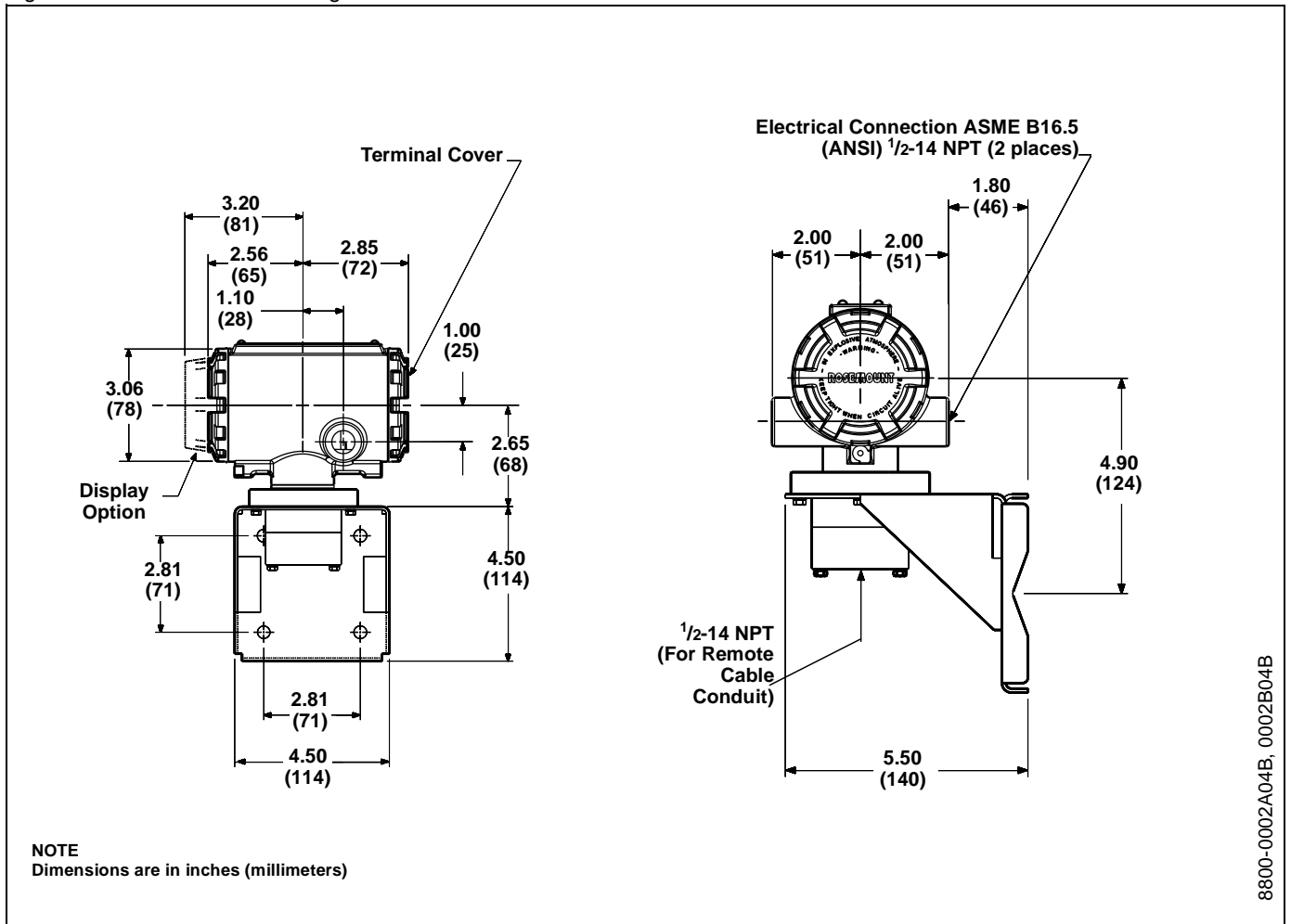

Figure 2-17. Dimensional Drawings for Remote Mount Wafer-Style Flowmeters
(1/2- through 8-in./15 through 200 mm Line Sizes)

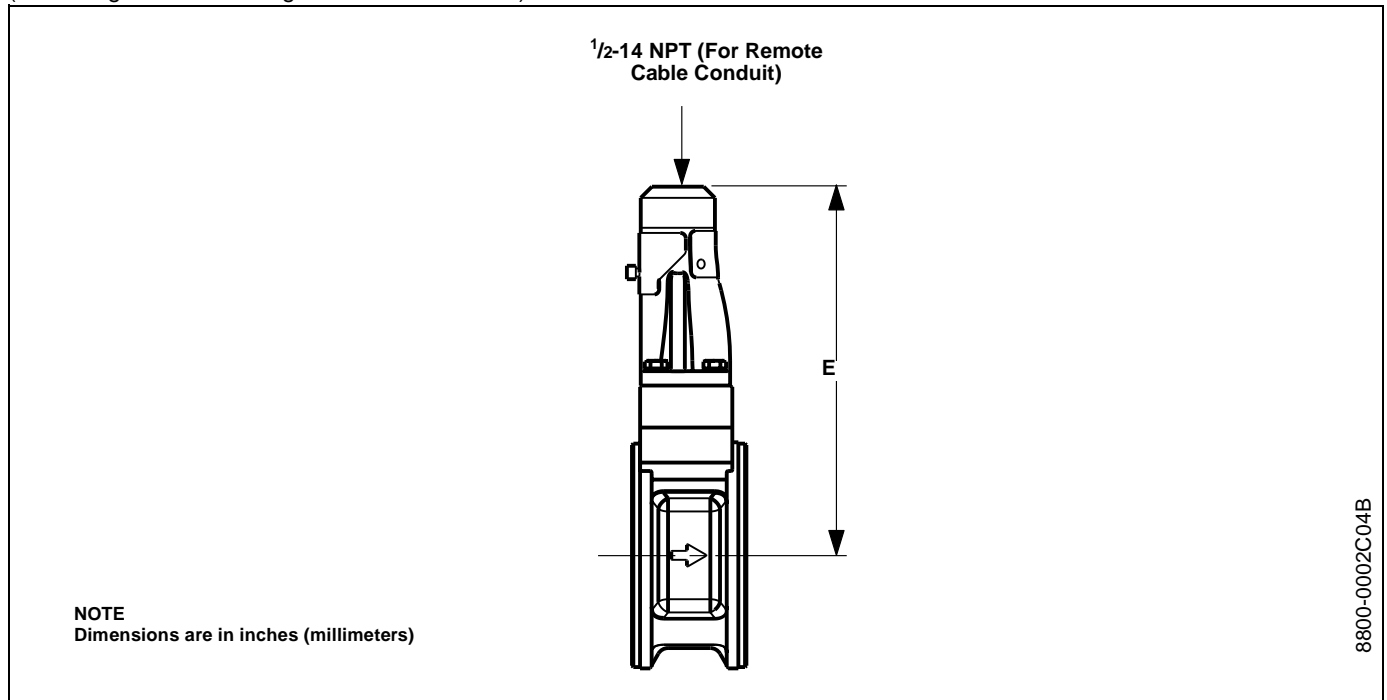

Table 2-15. Model 8800C - Stainless Steel Wafer

Nominal Size Inch (mm)	E Wafer Style Inch (mm)
	1/2 (15)
1 (25)	6.5 (165)
1 1/2 (40)	6.9 (175)
2 (50)	7.6 (193)
3 (80)	8.3 (211)
4 (100)	9.2 (234)
6 (150)	9.5 (241)
8 (200)	10.4 (264)

Table 2-16. Model 8800A - *Hastelloy*® Wafer

Nominal Size Inch (mm)	E Wafer Style Inch (mm)
	1/2 (15)
1 (25)	6.5 (165)
1 1/2 (40)	6.8 (173)
2 (50)	7.2 (183)
3 (80)	7.8 (198)
4 (100)	8.3 (211)
6 (150)	9.5 (241)
8 (200)	10.4 (264)

Rosemount Model 8800C Vortex Flowmeter

Figure 2-18. Dimensional Drawings for Flanged-and Dual-Sensor Flanged-Style Remote Mount Flowmeters (1/2-through 12-inch/15 through 300 mm Line Sizes)

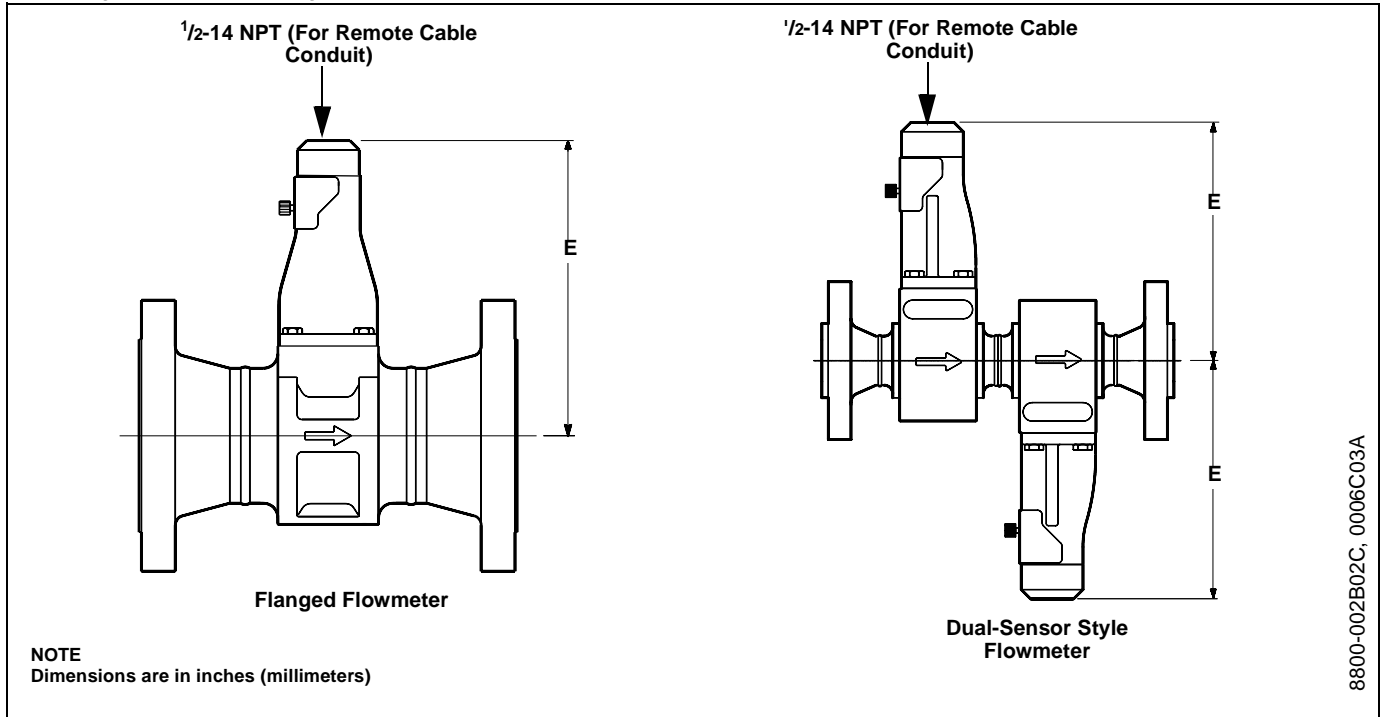

Table 2-17. Remote Mount, Flanged-and Dual Sensor Flowmeter Dimensions

Nominal Size Inch (mm)	E Flange Style Inch (mm)
1/2 (15)	6.4 (162)
1 (25)	6.5 (165)
1 1/2 (40)	6.8 (173)
2 (50)	7.2 (183)
3 (80)	7.8 (198)
4 (100)	8.3 (211)
6 (150)	9.5 (241)
8 (200)	10.4 (264)
10 (250)	11.5 (292)
12 (300)	12.4 (315)

Wiring Procedure

The signal terminals are located in a compartment of the electronics housing separate from the flowmeter electronics. Connections for a HART-based communicator and a current test connection are above the signal terminals. Figure 2-19 illustrates the power supply load limitations for the flowmeter.

Power Supply

The dc power supply should provide power with less than two percent ripple. The total resistance load is the sum of the resistance of the signal wiring and the load resistance of the controller, indicator, and related pieces. Note that the resistance of intrinsic safety barriers, if used, must be included.

NOTE

A minimum loop resistance of 250 ohms is required to exchange information with a HART-based communicator. With 250 ohms of loop resistance, the flowmeter will require a minimum power supply voltage (V_{ps}) of 16.8 volts to output 24 mA.

If a single power supply is used to power more than one Model 8800C flowmeter, the power supply used and circuitry common to the flowmeters should not have more than 20 ohms of impedance at 1200 Hz.

Figure 2-19. Power Supply Load Limitations

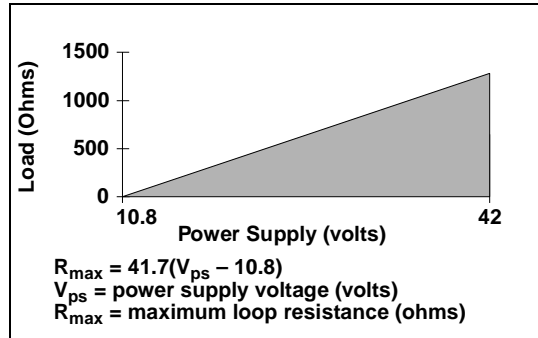

Table 2-18. Wire Resistance per 1,000 Feet (305 m)

Gage Number A.W.G.	Ohms per 1,000 ft (305 m) at 68 °F (20 °C) Equivalent
14	2.525
16	4.016
18	6.385
20	10.15
22	16.14
24	25.67

Analog Output

The flowmeter provides a 4–20 mA dc isolated current output, linear with the flow rate.

To make connections, remove the FIELD TERMINALS side cover of the electronics housing. All power to the flowmeter is supplied over the 4–20 mA signal wiring. Connect the wires as shown in Figure 2-22 on page 2-30.

NOTE

Twisted pairs are required to minimize noise pickup in the 4–20 mA signal and digital communication signal. Shielded signal wire is preferred, but not required. To ensure communication, wiring should be 24 AWG or larger and not exceed 5,000 ft (1500 m).

Pulse Output

NOTE

Remember when using the pulse output, all power to the flowmeter is still supplied over the 4–20 mA signal wiring.

The flowmeter provides an isolated transistor switch-closure frequency output signal proportional to flow, as shown in Figure 2-20. The frequency limits are as follows:

- Maximum Frequency = 10000 Hz
- Minimum Frequency = 0.0000035 Hz (1 pulse/79 hours)
- Duty Cycle = 50%
- For Frequencies ≤ 0.1 Hz the pulse width will equal 5 seconds
- Supply Voltage (V_s): 5 to 30 V dc
- Load Resistance: 100 Ω to 100 k Ω
 $V_s/0.02$ amps = Ohms (typical)
 $V_s/0.12$ amps = Ohms (max)
- Switch Closure: Transistor, open collector
Open contact < 50 μ A leakage
Close contact < 20 Ω

The output may drive an externally powered electromechanical or electronic totalizer, or may serve as a direct input to a control element.

To connect the wires, remove the FIELD TERMINALS side cover of the electronics housing. Connect the wires as shown in Figure 2-23 and Figure 2-24 on page 2-30.

Figure 2-20. Example: The pulse output will maintain a 50 percent duty cycle for all frequencies

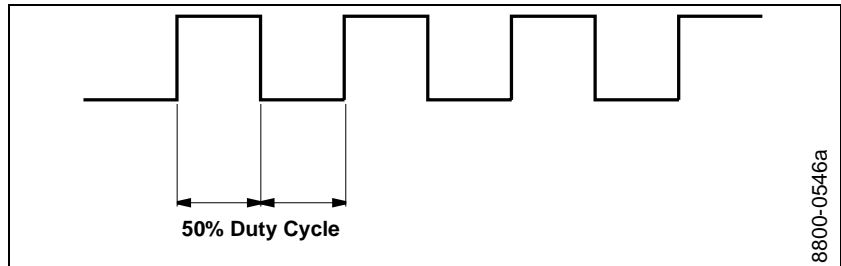

NOTE

When using pulse output, be sure to follow these precautions:

- Shielded twisted pair is required when the pulse output and 4–20 mA output are run in the same conduit or cable trays. Shielded wire will also reduce false triggering caused by noise pickup. Wiring should be 24 AWG or larger and not exceed 5,000 ft. (1500 m).
- Do not connect the powered signal wiring to the test terminals. Power could damage the test diode in the test connection.
- Do not run signal wiring in conduit or open trays with power wiring, or near heavy electrical equipment. If needed, ground signal wiring at any one point on the signal loop, such as the negative terminal of the power supply. The electronics housing is grounded to the spool.
- If the flowmeter is protected by the optional transient protector, you must provide a high-current ground connection from the electronics housing to earth ground. Also, tighten the ground screw in the bottom center of the terminal block to provide a good ground connection.

Figure 2-21. The Transient Terminal Block

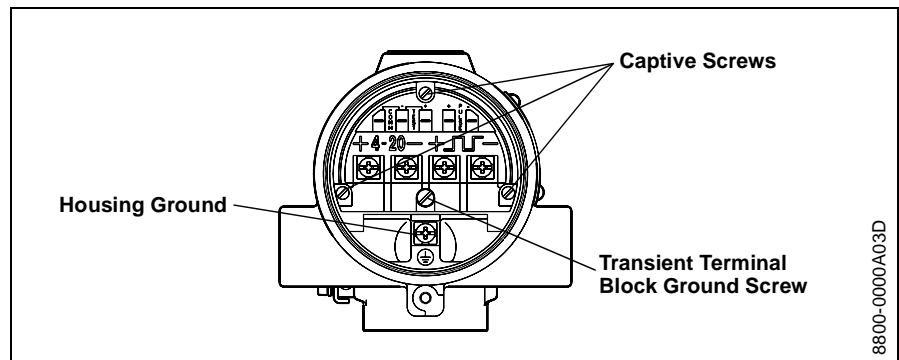

- Plug and seal all unused conduit connections on the electronics housing to avoid moisture accumulation in the terminal side of the housing.
- If the connections are not sealed, mount the flowmeter with the conduit entry positioned downward for drainage. Install wiring with a drip loop, making sure the bottom of the drip loop is lower than the conduit connections or the electronics housing.

Rosemount Model 8800C Vortex Flowmeter

Figure 2-22. 4-20mA Wiring

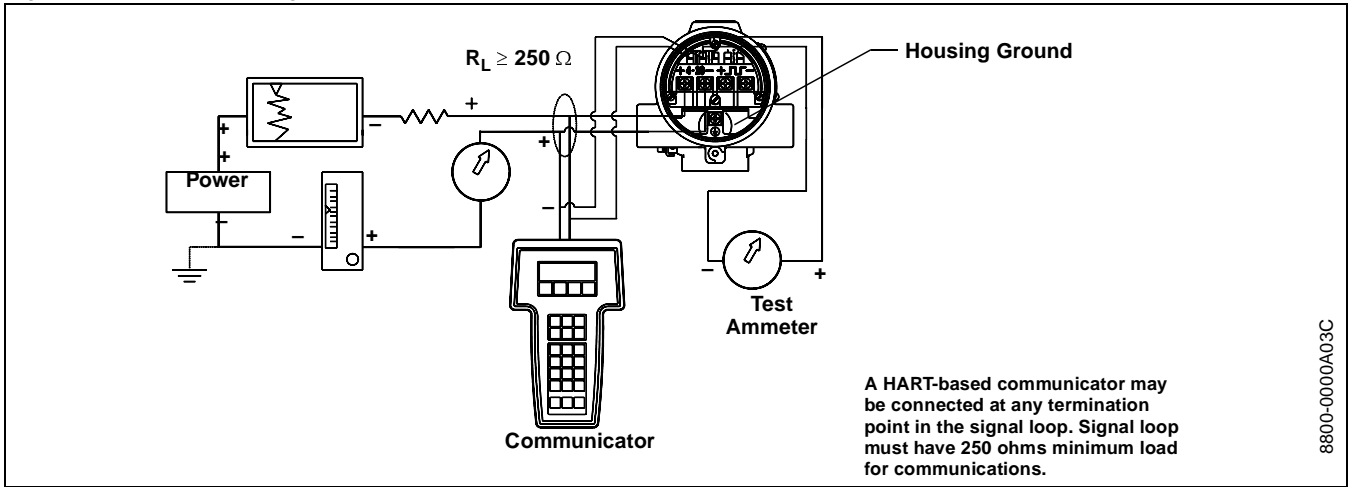

Figure 2-23. 4-20 mA and Pulse Wiring with Electronic Totalizer/ Counter

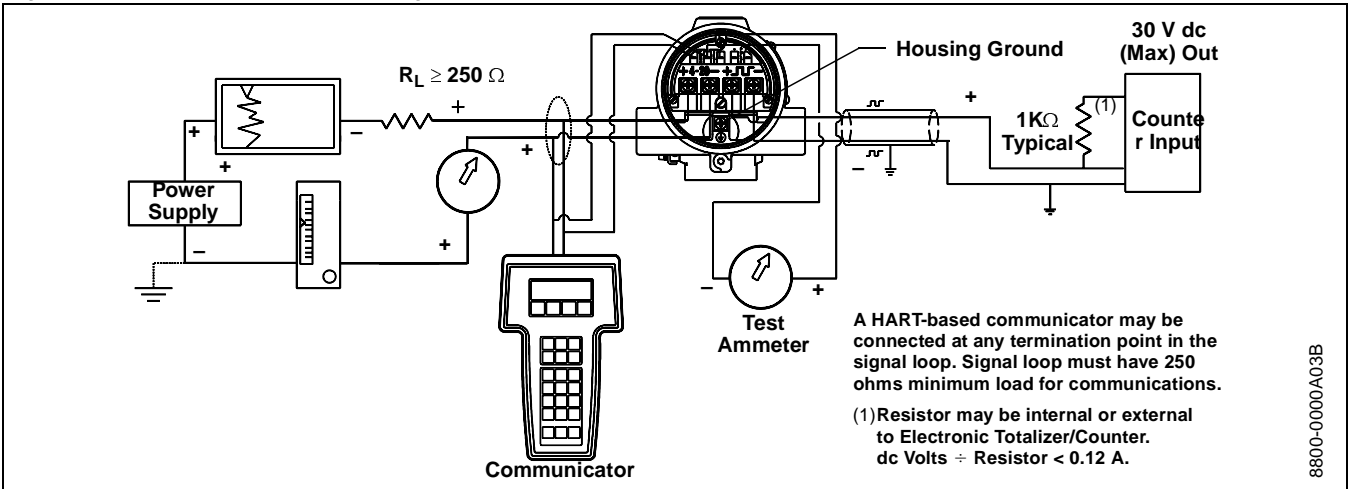
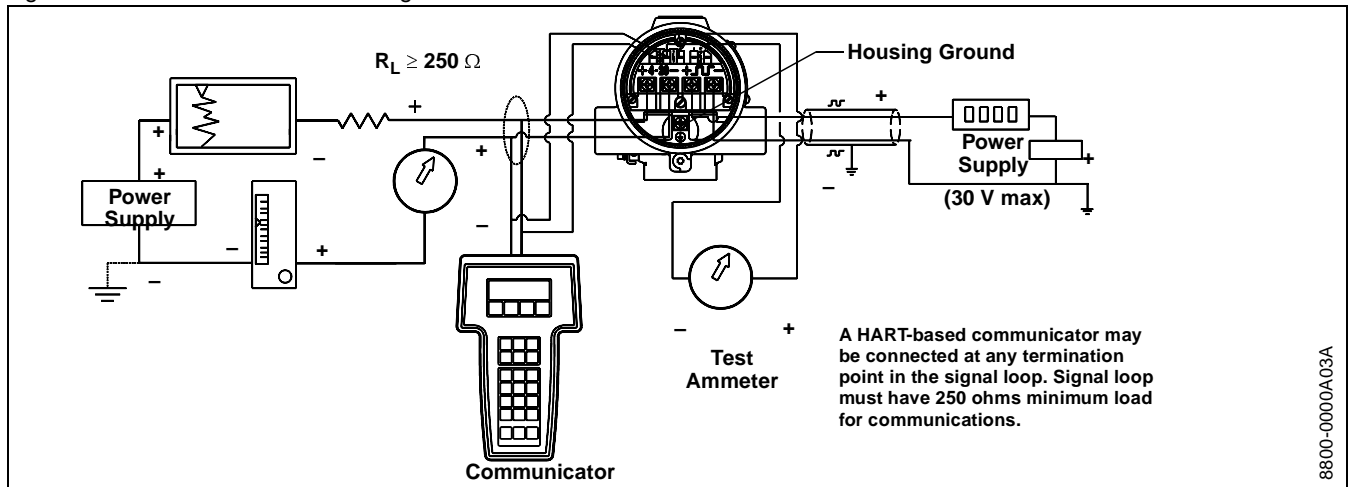

Figure 2-24. 4-20mA and Pulse Wiring with Electromechanical Counter



Remote Electronics

If you order one of the remote electronics options (options R10, R20, R30, or RXX), the flowmeter assembly will be shipped in two parts:

1. The meter body with an adapter installed in the support tube and an interconnecting coaxial cable attached to it.
2. The electronics housing installed on a mounting bracket.

Mounting

Mount the meter body in the process flow line as described earlier in this section. Mount the bracket and electronics housing in the desired location. The housing can be repositioned on the bracket to facilitate field wiring and conduit routing.

Cable Connections

Refer to Figure 2-25 and the following instructions to connect the loose end of the coaxial cable to the electronics housing. (See Remote Electronics Procedure on page 4-22 if connecting/disconnecting the meter adapter to the meter body.)

Figure 2-25. Remote Electronics Installation

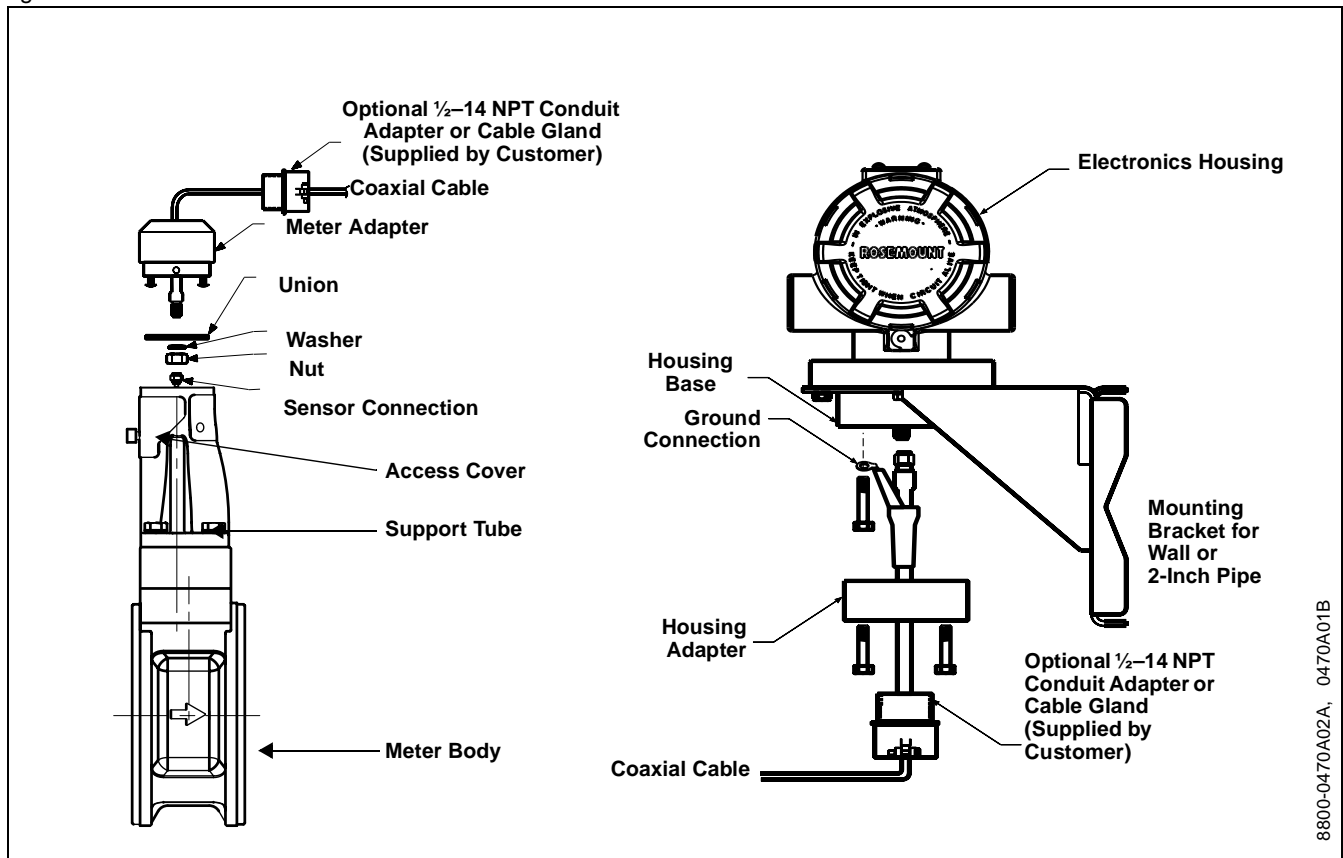

8800-0470A02A, 0470A01B

1. If you plan to run the coaxial cable in conduit, carefully cut the conduit to the desired length to provide for proper assembly at the housing. A junction box may be placed in the conduit run to provide a space for extra coaxial cable length.
2. Slide the conduit adapter or cable gland over the loose end of the coaxial cable and fasten it to the adapter on the meter body support tube.
3. If using conduit, route the coaxial cable through the conduit.
4. Place a conduit adapter or cable gland over the end of the coaxial cable.
5. Remove the housing adapter from the electronics housing.
6. Slide the housing adapter over the coaxial cable.
7. Remove one of the four housing base screws.
8. Attach the coaxial cable ground wire to the housing via the housing base ground screw.
9. Attach and securely tighten the coaxial cable nut to the connection on the electronics housing.
10. Align the housing adapter with the housing and attach with three screws.
11. Tighten the conduit adapter or cable gland to the housing adapter.

CAUTION

To prevent moisture from entering the coaxial cable connections, install the interconnecting coaxial cable in a single dedicated conduit run or use sealed cable glands at both ends of the cable.

Calibration

Model 8800C Flowmeters are wet-calibrated at the factory and need no further calibration during installation. The calibration factor (K-factor) is stamped on each meter body and is entered into the electronics. Verification can be accomplished with a HART Communicator or AMS.

**SOFTWARE
CONFIGURATION**

To complete the installation of the Model 8800C Vortex Flowmeter, configure the software to meet the requirements of your application. If the flowmeter was pre-configured at the factory, it may be ready to install. If not, refer to Section 3: Operation.

OPTIONS

LCD INDICATOR

The LCD indicator (option M5) provides local indication of the output and abbreviated diagnostic messages governing operation of the flowmeter. The indicator is located on the circuit side of the flowmeter electronics, leaving direct access to the signal terminals. An extended cover is required to accommodate the indicator. Figure 2-26 shows the flowmeter fitted with the LCD indicator and extended cover.

Figure 2-26. Model 8800C with Optional Indicator

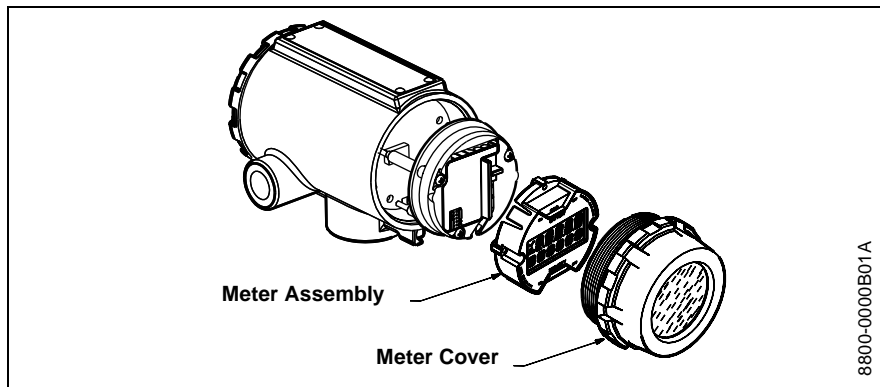

The indicator features an eight-character (and five alphanumeric) liquid crystal display that gives a direct reading of the digital signal from the microprocessor. During normal operation, the display can be configured to alternate between four readings:

1. Primary flow variable in engineering units
2. Percent of range
3. Totalized flow
4. 4–20 mA electrical current output

Figure 2-27 shows the indicator display with all segments lit.

Figure 2-27. Optional Liquid Crystal Display

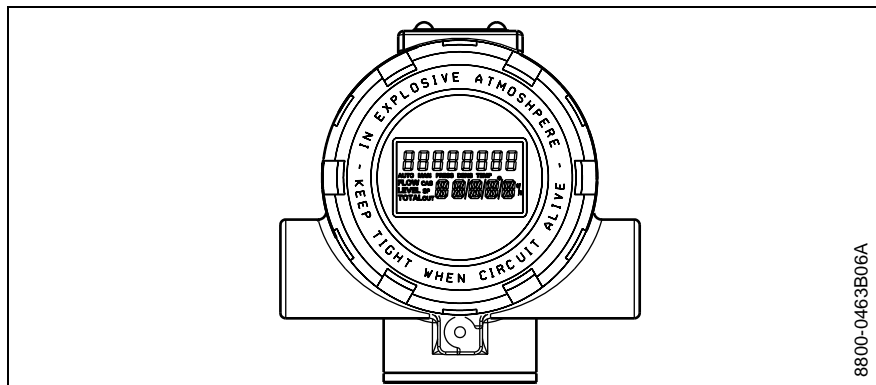

A HART-based communicator can be used to change the engineering units displayed on the indicator. (See Section 3: Operation for more information).

Installing the Indicator

For flowmeters ordered with the LCD indicator, the indicator is shipped installed. When purchased separately from the Model 8800C, you must install the indicator using a small instrument screwdriver and the indicator kit (part number 8800-5640-0002). The indicator kit includes:

- One LCD indicator assembly
- One extended cover with o-ring installed
- One connector
- Two mounting screws
- Two jumpers

Referring to Figure 2-26, use the following steps to install the LCD indicator:

1. If the flowmeter is installed in a loop, secure the loop and disconnect the power.
2. Remove the flowmeter cover on the electronics side.

NOTE

The circuit board is electrostatically sensitive. Be sure to observe handling precautions for static-sensitive components.

3. Insert the mounting screws into the LCD indicator.
4. Remove the two jumpers on the circuit board that coincide with the Alarm and the Security settings.
5. Insert the connector into the Alarm / Security junction.
6. Gently slide the LCD indicator onto the connector and tighten the screws into place.
7. Insert jumpers into ALARM and SECURITY positions on the face of the LCD indicator.
8. Attach the extended cover and tighten at least one-third turn past o-ring contact.

NOTE

The indicator may be installed in 90-degree increments for easy viewing. One of the four connectors on the back of the indicator assembly must be positioned to fit into the ten-pin connector on the electronic board stack.

Note the following LCD temperature limits:

Operating: -4 to 185 °F (-20 to 85 °C)

Storage: -50 to 185 °F (-46 to 85 °C)

Diagnostic Messages

In addition to the output, the LCD indicator displays diagnostic messages for troubleshooting the flowmeter. These messages are as follows:

SELFTEST

The flowmeter is in the process of performing an electronics self test.

FAULT_ROM

The flowmeter electronics has undergone a EPROM checksum fault. Contact your Field Service Center.

FAULT_EEROM

The flowmeter electronics has undergone a EEPROM checksum fault. Contact your Field Service Center.

FAULT_RAM

The flowmeter electronics has undergone a RAM test fault. Contact your Field Service Center.

FAULT_ASIC

The flowmeter electronics has undergone a digital signal processing ASIC update fault. Contact your Field Service Center.

FAULT_CONFIG

The flowmeter electronics has lost critical configuration parameters. This message will be followed by information detailing the missing configuration parameters. Contact your Field Service Center.

FAULT_COPRO

The flowmeter electronics has detected a fault in the math coprocessor. Contact your Field Service Center.

FAULT_SFTWR

The flowmeter electronics has detected a non-recoverable fault in the software operation. Contact your Field Service Center.

FAULT_BDREV

The flowmeter electronics has detected incompatible electronics hardware. Contact your Field Service Center.

FAULT_LOOPV

The flowmeter electronics has detected insufficient voltage to power the sensor board. Most likely the cause is low voltage at transmitter 4–20 mA terminals. Contact your Field Service Center.

FAULT_SDCOM

The flowmeter electronics has detected an unexpected sigma-delta ASIC communications fault. Contact your Field Service Center.

FAULT_SDPLS

The flowmeter electronics has detected a loss of flow data from the sigma-delta ASIC. Contact your Field Service Center.

FAULT_TASK(#)

The flowmeter electronics has detected a fatal error. Record (#) and contact your Field Service Center.

TRANSIENT PROTECTION

The optional transient terminal block prevents damage to the flowmeter from transients induced by lightning, welding, heavy electrical equipment, or switch gears. The transient protection electronics are located in the terminal block.

The transient terminal block meets the following specifications:

ASME B16.5 (ANSI)/IEEE C62.41 - 1980 (IEEE 587) Categories A, B.

3 kA crest ($8 \times 20 \mu\text{s}$).

6 kV crest ($1.2 \times 50 \mu\text{s}$).

6 kV/0.5 kA (0.5 μs , 100 kHz, ring wave).

NOTE

The ground screw inside the terminal housing must be tightened for the proper operation of the transient protection. Also, a high-current ground connection to earth is required.

**Installing the
Transient Protector**

For flowmeters ordered with the transient protector option (T1), the protector is shipped installed. When purchased separately from the Model 8800C, you must install the protector on a Model 8800C flowmeter using a small instrument screwdriver, a pliers, and the transient protection kit (part number 8800-5106-1002 or 8800-5106-1004).

The transient protection kit includes the following:

- One transient protection terminal block assembly
- Three captive screws
- One ground screw

Use the following steps to install the transient protector:

1. If the flowmeter is installed in a loop, secure the loop and disconnect power.
2. Remove the field terminal side flowmeter cover.
3. Remove the captive screws.
4. Use pliers to pull the terminal block out of the housing.
5. Inspect the connector pins for straightness.
6. Place the new terminal block in position and carefully press it into place. The terminal block may have to be moved back and forth to get the connector pins started into the sockets.
7. Tighten the captive screws.
8. Install and tighten the ground screw.

Figure 2-28. The Transient Terminal Block

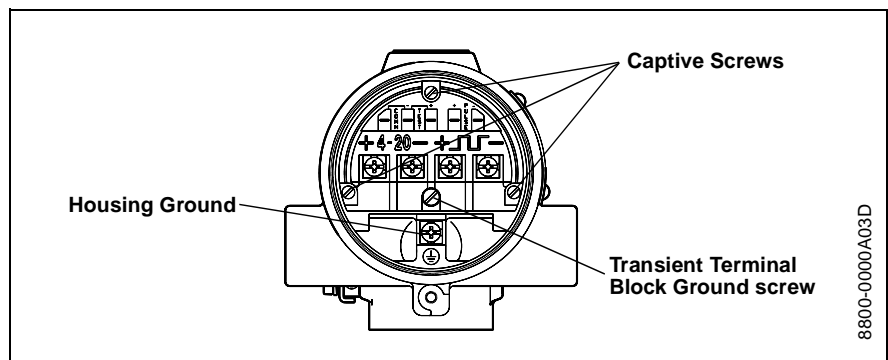

9. Replace the cover.

Review	page 3-1
Process Variables	page 3-1
Diagnostics/Service	page 3-3
Basic Setup	page 3-5
Advanced Functionality	page 3-12
Detailed Set-Up	page 3-12

The software configuration settings for the Model 8800C can be accessed through a HART-based communicator or through a control system. The software functions for the HART Communicator are described in detail in this section of the manual. It provides an overview and summary of communicator functions. For more complete instructions, see the communicator manual.

Before operating the Model 8800C in an actual installation, you should review all of the factory set configuration data to ensure that they reflect the current application.

REVIEW

HART Comm.	1, 5
------------	------

Review the flowmeter configuration parameters set at the factory to ensure accuracy and compatibility with your particular application of the flowmeter. Once you have activated the Review function, scroll through the data list to check each variable in the configuration data list.

The last step of start-up and commissioning is to check the flowmeter output to ensure that the flowmeter is operating properly. Model 8800C digital outputs include: flow rate, flow rate as a percent of range, analog output, vortex shedding rate, pulse rate, and totalized flow.

PROCESS VARIABLES

HART Comm.	1, 1
------------	------

The process variables for the Model 8800C provide the flowmeter output. They measure flow in several ways that reflect your needs and the configuration of your flowmeter. When commissioning a flowmeter, review each process variable, its function and output, and take corrective action if necessary before using the flowmeter in a process application.

Flow – The actual measured **flow** rate in the line. On the bench, the PV value should be zero. Check the units on the PV to make sure they are configured correctly. If the units format is not correct, refer to PV Units on page 3-14. Use the Process Variable Units function to select the units for your application.

Percent of Range – The **process variable as a percentage of range** provides a gauge as to where the current flow of the meter is within the configured range of the flowmeter. For example, the range may be defined as 0 gal/min to 20 gal/min. If the current flow is 10 gal/min, the percent of range is 50 percent.

Analog Output – The **analog output** variable provides the analog value for the flow rate. The analog output refers to the industry standard output in the 4–20 mA range. Check the analog output value against the actual loop reading given by a millimeter. If it does not match, a 4–20 mA trim is required. See D/A Trim (Digital-to-Analog Trim).

Totalizer – **Totalizer** provides a reading of the total flow of the flowmeter since the totalizer was last reset. The totalizer value should be zero during commissioning on the bench, and the units should reflect the volume units of the flow rate. If the totalizer value is not zero, it may need to be reset.

View Other Variables– **Pulse Output** provides the actual pulse reading from the meter if your meter includes the pulse output option. This digital value is always available, even without the pulse output option.

Shedding Frequency measures the frequency of vortex pulses around the shedder bar.

Totalizer

HART Comm.	1, 1, 4
------------	---------

Totalizer tallies the total amount of liquid or gas that has passed through the flowmeter since the totalizer was last reset.

It enables you to change the settings of the totalizer.

Total

HART Comm.	1, 1, 4, 1
------------	------------

Total — Provides the output reading of the totalizer. Its value is the amount of liquid or gas that has passed through the flowmeter since the totalizer was last reset

Start

HART Comm.	1, 1, 4, 2
------------	------------

Start — Starts the totalizer counting from its current value.

Stop

HART Comm.	1, 1, 4, 3
------------	------------

Stop — Interrupts the totalizer count until it is restarted again. This feature is often used during pipe cleaning or other maintenance operations.

Reset

HART Comm.	1, 1, 4, 4
------------	------------

Reset — Stops the totalizer and returns the totalizer value to zero.

NOTE

The totalizer value is saved in the EEPROM memory of the electronics every three minutes if the temperature is less than 131 °F (55 °C) or every six minutes if the temperature is greater than 131 °F (55 °C). Should power to the transmitter be interrupted, the totalizer value will start at the last saved value when power is re-applied.

DIAGNOSTICS/SERVICE

HART Comm.	1, 2
------------	------

Use the following functions to verify that the flowmeter is functioning properly, or when you suspect component failure or a problem with loop performance, or when instructed to do so as part of a troubleshooting procedure. Initiate each test with the HART Communicator or other HART-based communications device.

Test/Status

HART Comm.	1, 2, 1
------------	---------

Under **Test/Status** choose from View Status or Self Test.

View Status

HART Comm.	1, 2, 1, 1
------------	------------

View Status allows you to view any error messages that may have occurred.

Self Test

HART Comm.	1, 2, 1, 2
------------	------------

Although the Model 8800C performs continuous self-diagnostics, you can initiate an immediate diagnostic to check for possible electronics failure.

Self Test checks proper communications with the transmitter and provides diagnostic capabilities for transmitter problems. Follow on-screen instructions if problems are detected, or check the appropriate appendix for error messages relating to your communicator.

Loop Test

HART Comm.	1, 2, 2
------------	---------

Loop Test verifies the output of the flowmeter, the integrity of the loop, and the operation of any recorders or similar devices. Conduct the loop test after the flowmeter is installed in the field.

If the meter is located in a loop with a control system, the loop will have to be set to manual control before the loop test is performed.

Verify that the ammeter in the test loop reads 4 mA. If the output is 4 mA, end the loop test. If the output is not 4 mA, the flowmeter may require a digital trim. If the digital trim does not set the 4 mA output, the electronics may be malfunctioning.

Pulse Output Test

HART Comm.	1, 2, 3
------------	---------

Pulse Output Test is a fixed frequency mode test that checks the integrity of the pulse loop. It tests that all connections are good and that pulse output is running on the loop.

Flow Simulation

HART Comm.	1, 2, 4
------------	---------

Flow Simulation enables you to check the electronics functionality. This can be verified with either the Flow Simulation Internal or Flow Simulation External method.

Flow

HART Comm.	1, 2, 4, 1
------------	------------

Shows the flow value in current engineering units for the flow simulation.

Shedding Frequency

HART Comm.	1, 2, 4, 2
------------	------------

Shows the shedding frequency for the flow simulation.

Configure Flow Simulation

HART Comm.	1, 2, 4, 3
------------	------------

Allows you to configure your flow simulation (internal or external).

Simulate Flow Internal

HART Comm.	1, 2, 4, 3, 1
------------	---------------

The simulate flow internal function will automatically disconnect the sensor and enable you to select the configuration of the internal simulate (fixed or varying).

Fixed Flow

HART Comm.	1, 2, 4, 3, 1, 1
------------	------------------

The fixed flow simulation signal can be entered in either a percent of range or flow rate in current engineering units.

Varying Flow

HART Comm.	1, 2, 4, 3, 1, 2
------------	------------------

The minimum and maximum flowrate can be entered in either percent of range or as a flow rate in current engineering units. The ramp time can be entered in seconds from a minimum of 0.533 seconds to a maximum of 34951 seconds.

Simulate Flow External

HART Comm.	1, 2, 4, 3, 2
------------	---------------

Simulate flow external allows you to disconnect the sensor electronically so an external frequency source can be used.

Enable Normal Flow

HART Comm.	1, 2, 4, 4
------------	------------

Enable normal flow allows you to exit the flow simulation mode (internal or external) and return to normal operation mode.

Mode

HART Comm.	1, 2, 4, 5
------------	------------

Mode allows you to view which flow simulation mode you are in:

- Internal (flow simulation – internal)
- Snsr Offln (flow simulation – external)
- Norm Flow (normal flow operation)

D/A Trim

HART Comm.	1, 2, 5
------------	---------

D/A Trim (Digital-to-Analog Trim) enables you to check and trim the analog output in a single function. If the analog output is trimmed, it will be scaled proportionally through the range of the output.

To trim the digital-to-analog output, initiate the D/A Trim function and connect an ammeter to the loop to measure the actual analog output of the meter. Follow the on-screen functions to complete the task.

Scaled D/A Trim

HART Comm.	1, 2, 6
------------	---------

Scaled D/A Trim enables you to calibrate the flowmeter analog output using a different scale than the standard 4-20 mA output scale.

Non-scaled D/A Trimming (described above), is typically performed using an ammeter where calibration values are entered in units of milliamperes. Both non-scaled D/A trimming and scaled D/A trimming allow you to trim the 4-20mA output to approximately $\pm 5\%$ of the nominal 4mA end point and $\pm 3\%$ of the nominal 20mA end point.

Scaled D/A Trimming allows you to trim the flowmeter using a scale that may be more convenient based upon your method of measurement.

For example, it may be more convenient for you to make current measurements by direct voltage readings across the loop resistor. If your loop resistor is 500 Ohms, and you want to calibrate the meter using voltage measurements made across this resistor, you could rescale (select CHANGE on the 275) your trim points from 4-20mA to 4-20mA x 500 ohm or 2-10 VDC. Once your scaled trim points have been entered as 2 and 10, you can now calibrate your flowmeter by entering voltage measurements directly from the voltmeter.

Shed Freq at URV

HART Comm.	1, 2, 7
------------	---------

Shed Freq at URV function gives the shedding frequency corresponding to your URV.

BASIC SETUP

HART Comm.	1, 3
------------	------

The Model 8800C must be configured for certain basic variables in order to be operational. In most cases, all of these variables are pre-configured at the factory. Configuration may be required if your Model 8800C is not configured or if the configuration variables need revision.

Tag

HART Comm.	1, 3, 1
------------	---------

Tag is the quickest way to identify and distinguish between flowmeters. Flowmeters can be tagged according to the requirements of your application. The tag may be up to eight characters long.

Service Type

HART Comm.	1, 3, 2
------------	---------

The flowmeter can be used for liquid or gas/steam applications, but it must be configured specifically for the application. If the flowmeter is not configured for the proper service type, readings will be inaccurate. Select the appropriate **Service Type** for your application:

- Liquid
- Gas/Steam

PV Units

HART Comm.	1, 3, 3
------------	---------

The Model 8800C flowmeter displays Volumetric, Mass, STD/Normal, Velocity, or Special units as determined by your application. Use the **Process Variable Units (PV)** function to select the units for your application and needs.

NOTE

After changing flow units, be sure to send data to the transmitter so that the associated variables (4–20 mA points, etc.) will be recalculated by the microprocessor. The Model 8800C recalculates all variables that depend on units. You may then change any of the remaining parameters.

The following flow unit options are available:

Volumetric Units

HART Comm.	1, 3, 3, 1
------------	------------

Volumetric Units (1 bbl = 42 gal)

- gal/s impgal/s
- gal/min impgal/min
- gal/h impgal/h
- gal/d impgal/d
- ACFM L/s
- ACFH L/min
- ACFD L/h
- bbl/min L/d
- bbl/h ACMM
- bbl/d ACMH
- ACMD
- MACMD

Mass Units

HART Comm.	1, 3, 3, 2, 1
------------	---------------

Mass Flow Units

If you select a **Mass Units** option, you must enter process density in your configuration. (1 ston = 2000 lb; 1 ton = 1000 kg)

- lb/s ston/h
- lb/min ston/d
- lb/h met ton/h
- lb/d met ton/d
- kg/s
- kg/min
- kg/h
- kg/d

Process Density

HART Comm.	1, 3, 3, 2, 2
------------	---------------

Process Density and **Density Units** are required only if you have designated mass units for your flow rate units. You will first be prompted for density units. It is required for the conversion from volumetric units to mass units. If you select volumetric units or special units, process density is not required.

For example, if you have set flow units to kg/sec rather than gal/sec, a density is required to convert the measured volumetric flow into the desired mass flow.

NOTE

If mass units are configured as special units, process density must be figured into the special units conversion number. Process density as a separate value will be de-activated.

If mass units are chosen, you must enter the density of your process fluid into the software. Be careful to enter the correct density. The mass flow rate is calculated using this user-entered density, and any error in this number will cause error in the mass flow measurement. If fluid density is changing over time, it is recommended that volumetric flow units be used.

STD/Normal Flow Units

HART Comm.	1, 3, 3, 3, 1
------------	---------------

Standard/Normal Flow Units

SCFM

SCFH

NCMM

NCMH

NCMD

The model 8800C allows you to measure **Standard** or **Normal Flow Units**. Configure the software in one of two ways:

1. Enter **Density Ratio** to convert from actual flow rate to standard flow rate.
2. Enter the process and base conditions. (The Model 8800C electronics will then calculate the density ratio for you).

NOTE

Be careful to calculate and enter the correct conversion factor. Standard flow is calculated with the conversion factor you enter. Any error in the factor entered will result in an error in the standard flow measurement. If pressure and temperature changes over time, use actual volumetric flow units. The Model 8800C does not compensate for changing temperature and pressure.

Density Ratio

HART Comm.	1, 3, 3, 3, 2
------------	---------------

Density Ratio is used to convert actual volumetric flow to standard volumetric flow rates based on the following equations:

$$\text{Conversion factor} = \frac{\text{density at actual (flowing) conditions}}{\text{density at standard (base) conditions}}$$

$$\text{Conversion factor} = \frac{T_b \times P_f \times Z_b}{T_f \times P_b \times Z_f}$$

Calculate Density Ratio

HART Comm.	1, 3, 3, 3, 3
------------	---------------

Calculate Density Ratio will calculate the density ratio (shown above) based on user entered process and base conditions.

Operating Conditions

HART Comm.	1, 3, 3, 3, 3, 1
------------	------------------

T_f = absolute temperature at actual (flowing) conditions in degrees Rankine or Kelvin. (The transmitter will convert from degrees Fahrenheit or degrees Celsius to degrees Rankine or Kelvin respectively.)

P_f = absolute pressure at actual (flowing) conditions psia or KPa absolute. (The transmitter will convert from psi, bar, kg/sqcm, kpa, or mpa to psi or kpa for calculation. Note that pressure values must be absolute.)

Z_f = compressibility at actual (flowing) conditions (dimensionless)

Base Conditions

HART Comm.	1, 3, 3, 3, 3, 2
------------	------------------

T_b = absolute temperature at standard (base) conditions degrees Rankine or Kelvin. (The transmitter will convert from degrees Fahrenheit or degrees Celsius to degrees Rankine or Kelvin respectively.)

P_b = absolute pressure at standard (base) conditions psia or KPa absolute. (The transmitter will convert from psi, bar, kg/sqcm, kpa, or mpa to psi or kpa for calculation. Note that pressure values must be absolute.)

Z_b = compressibility at standard (base) conditions (dimensionless)

Example

Configure the Model 8800C to display flow in standard cubic feet per minute (SCFM). (Fluid is hydrogen flowing at conditions of 170 °F and 100 psia.) Assume base conditions of 59 °F and 14.696 psia.)

$$\text{Conversion factor} = \frac{518.57 \text{ }^\circ\text{R} \times 100 \text{ psia} \times 1.0006}{629.67 \text{ }^\circ\text{R} \times 14.7 \text{ psia} \times 1.0036} = 5.587$$

Velocity Units

HART Comm.	1, 3, 3, 4
------------	------------

ft/sec m/sec

Special Units

HART Comm.	1, 3, 3, 5
------------	------------

Special Units allows you to create flow rate units that are not among the standard options. They can be mass or volumetric units.

Configuration of a special unit involves entry of these values: base volume unit, base time unit, user defined unit and conversion number. Suppose you want the Model 8800C to display flow in barrels per minute instead of gallons per minute, and one barrel is equal to 31.0 gallons.

- Base volume unit: gal
- Base time unit: min
- User defined unit: br
- Conversion number: 31.0

See the specific variables listed below for more information on setting special units.

NOTE

The HART-based communicator will display the converted reading. The actual unit specification does not appear.

Base Volume Unit

HART Comm.	1, 3, 3, 5, 1
------------	---------------

Base Volume Unit is the unit from which the conversion is made. You must select one of the HART Communicator defined unit options:

- Gallons (gal)
- Liters (L)
- Imperial gallons (Impgal)
- Cubic meters (Cum)
- Barrels (bbl) where 1 standard bbl=42 gal
- Cubic Feet (cuft)

Base Time Unit

HART Comm.	1, 3, 3, 5, 2
------------	---------------

Base Time Unit provides the time unit from which to calculate the special units. For example, if your special units is a volume per minute, select minutes. Choose from the following units:

- Seconds (s)
- Minutes (min)
- Hours (h)
- Days (d)

User Defined Unit

HART Comm.	1, 3, 3, 5, 3
------------	---------------

User Defined Unit is a format variable that provides a record of the flow units to which you are converting. The LCD on the Model 8800C will display the actual units you define. The HART communicator will simply display "SPCL." There are four characters available to store the new units designation.

Conversion Number

HART Comm.	1, 3, 3, 5, 4
------------	---------------

Conversion Number is used to relate base units to special units. For a straight conversion of volume units from one to another, the conversion number is the number of base units in the new unit.

For example, if you are converting from gallons to barrels and there are 31 gallons in a barrel, the conversion factor is 31. The conversion equation is as follows (where barrels is the new volume unit):

$$1 \text{ barrel} = 31 \text{ gallons}$$

NOTE

If reviewing parameters, the number is shown as the conversion factor from base units to special units (i.e., 1/31).

Range Values

HART Comm.	1, 3, 4
------------	---------

Range Values enables you to maximize resolution of analog output. The meter is most accurate when operated within the expected flow ranges for your application. Setting the range to the limits of expected readings will maximize flowmeter performance.

The range of expected readings is defined by the Lower Range Value (LRV) and Upper Range Value (URV). Set the LRV and URV within the limits of flowmeter operation as defined by the line size and process material for your application. Values set outside that range will not be accepted.

Select each variable and enter the appropriate value. The new range is defined by these values.

Process Temperature

HART Comm.	1, 3, 5
------------	---------

Process Temperature is needed for the electronics to compensate for thermal expansion of the flowmeter as the process temperature differs from the reference temperature. Process temperature is the temperature of the liquid or gas in the line during flowmeter operation.

NOTE

The temperature may also be changed under Calculate Density Ratio.

Mating Pipe ID (Inside Diameter)

HART Comm.	1, 3, 6
------------	---------

The **Pipe ID (Inside Diameter)** of the pipe adjacent to the flow meter can cause entrance effects that may alter flowmeter readings. You must specify the exact inside diameter of the pipe to correct for these effects. Enter the appropriate value for this variable.

Pipe ID values for schedule 10, 40, and 80 piping are given in Table 3-1. If the piping in your application is not one of these, you may need to contact the manufacturer for exact Pipe ID.

Table 3-1. Pipe IDs for Schedule 10, 40, and 80 Piping

Pipe Size Inches (mm)	Schedule 10 Inches (mm)	Schedule 40 Inches (mm)	Schedule 80 Inches (mm)
½ (15)	0.674 (17.12)	0.622 (15.80)	0.546 (13.87)
1 (25)	1.097 (27.86)	1.049 (26.64)	0.957 (24.31)
1½ (40)	1.682 (42.72)	1.610 (40.89)	1.500 (38.10)
2 (50)	2.157 (54.79)	2.067 (52.50)	1.939 (49.25)
3 (80)	3.260 (82.80)	3.068 (77.93)	2.900 (73.66)
4 (100)	4.260 (108.2)	4.026 (102.3)	3.826 (97.18)
6 (150)	6.357 (161.5)	6.065 (154.1)	5.716 (145.2)
8 (200)	8.329 (211.6)	7.981 (202.7)	7.625 (193.7)
10 (250)	10.420 (264.67)	10.020 (254.51)	9.562 (242.87)
12 (300)	12.390 (314.71)	12.000 (304.80)	11.374 (288.90)

Damping

HART Comm.	1, 3, 7
------------	---------

Damping changes the response time of the flowmeter to smooth variations in output readings caused by rapid changes in input.

Damping is applied to the Analog Output, Process Variable, and Percent Range. This will not affect the Pulse Output or Total.

NOTE

If the vortex shedding frequency is slower than the damped value selected, no damping is applied.

The default damping value is 2.0 seconds. This can be reset to any value between 0.2 and 255 seconds.

Determine the appropriate damping setting based on the necessary response time, signal stability, and other requirements of the loop dynamics in your system.

ADVANCED FUNCTIONALITY

The Model 800C enables you to configure the flowmeter for a wider range of applications and special situations. These functions are grouped as follows under Detailed Set-Up:

DETAILED SET-UP

HART Comm.	1, 4
------------	------

- Characterize Meter
- PV Units
- Configure Outputs
- Signal Processing
- Device Information

Characterize Meter

HART Comm.	1, 4, 1
------------	---------

The Meter Body variables provide configuration data that are unique to your Model 8800C. The settings of these variables can effect the compensated K-factor on which the primary variable is based. These data are provided during factory configuration and should not be changed unless the physical make-up of your Model 8800C is changed.

Mating Pipe I.D.

HART Comm.	1, 4, 1, 1
------------	------------

The inside diameter of the pipe adjacent to the flow meter can cause entrance effects that may alter flowmeter readings. The exact inside diameter of the pipe must be specified to correct for these effects. Enter the appropriate value for this variable.

Mating Pipe ID values for schedule 10, 40, and 80 piping are given in Table 3-1. If the piping in your application is not one of these, you may need to contact the manufacturer for exact Pipe ID.

K-Factor

HART Comm.	1, 4, 1, 2
------------	------------

The HART Communicator provides information on Reference and Compensated **K-factor** values.

The *Reference K-factor* is factory set according to the actual K-factor for your application. It should only be changed if you replace parts of the flowmeter. Contact your Rosemount representative for details.

The *Compensated K-factor* is based on the reference K-factor as compensated for the given process temperature, wetted materials, body number, and pipe ID. Compensated K-factor is an informational variable that is calculated by the electronics of your flowmeter.

Wetted Material

HART Comm.	1, 4, 1, 3
------------	------------

Wetted Material is a factory set configuration variable that reflects the construction of your flowmeter.

- 316 SST
- Hastelloy-C®

Meter Body Number

HART Comm.	1, 4, 1, 4
------------	------------

Meter Body Number is a factory set configuration variable that stores the body number of your particular flowmeter and the type of construction. The meter body number is found to the right of the body number on the meter body tag, which is attached to the support tube of the meter body.

The format of this variable is a number followed by an alpha numeric character. The number designates the body number. The alpha numeric character designates the meter body type. There are three options for the alpha numeric character:

1. None – Indicates welded meter construction
2. A – Indicates welded meter construction
3. B – Indicates cast construction

Flange Type

HART Comm.	1, 4, 1, 5
------------	------------

Flange Type enables you to specify the type of flange on the flowmeter for later reference. This variable is preset at the factory but can be changed if necessary.

- Wafer
- ASME B16.5 (ANSI) 150
- ASME B16.5 (ANSI) 300
- ASME B16.5 (ANSI) 600
- ASME B16.5 (ANSI) 900
- PN 10
- PN 16
- PN 25
- PN 40
- PN 64
- PN 100
- PN 160
- JIS 10k
- JIS 20k
- JIS 40k
- Special

Installation Effect

HART Comm.	1, 4, 1, 6
------------	------------

Installation Effect enables you to compensate the flowmeter for installation effects. See reference graphs located in Technical Data Sheet 00816-0100-3250 for the percent of K-factor shift based on entrance effects of upstream disturbances. This value is entered as a percentage of the range of +1.5% to -1.5%.

PV Units

HART Comm.	1, 4, 2
------------	---------

Refer to the previous pages for more details regarding the following: Volumetric Units, Mass Units, STD/Normal Units, Velocity Units, and Special Units.

Configure Options

HART Comm.	1, 4, 3
------------	---------

The Model 8800C is digitally adjusted at the factory using precision equipment to ensure accuracy. You should be able to install and operate the flowmeter without a D/A Trim.

Analog Output

HART Comm.	1, 4, 3, 1
------------	------------

For maximum accuracy, calibrate the analog output and, if necessary, trim for your system loop. The D/A Trim procedure alters the conversion of the digital signal into an analog 4–20 mA output.

Range Values

HART Comm.	1, 4, 3, 1, 1
------------	---------------

Range Values enables you to maximize resolution of analog output. The meter is most accurate when operated within the expected flow ranges for your application. Setting the range to the limits of expected readings will maximize flowmeter performance.

The range of expected readings is defined by the Lower Range Value (LRV) and Upper Range Value (URV). Set the LRV and URV within the limits of flowmeter operation as defined by the line size and process material for your application. Values set outside that range will not be accepted. Select each variable and enter the appropriate value. The new range is defined by these values.

Loop Test

HART Comm.	1, 4, 3, 1, 2
------------	---------------

Loop Test verifies the output of the flowmeter, the integrity of the loop, and the operation of any recorders or similar devices. Conduct the loop test after the flowmeter is installed in the field. If the meter is located in a loop with a control system, the loop will have to be set to manual control before the loop test is performed.

Verify that the ammeter in the test loop reads 4 mA. If the output is 4 mA, end the loop test. If the output is not 4 mA, the flowmeter may require a digital trim (see D/A Trim (Digital-to-Analog Trim)). If the digital trim does not set the 4 mA output, the receiving meter may be malfunctioning.

Alarm Jumper

HART Comm.	1, 4, 3, 1, 3
------------	---------------

Alarm Jumper lets you verify the alarm jumper setting.

D/A Trim (Digital-to-Analog Trim)

HART Comm.	1, 4, 3, 1, 4
------------	---------------

Digital-to-Analog Trim enables you to check and trim the analog output in a single function. If the analog output is trimmed, it will be scaled proportionally through the range of the output. To trim the digital-to-analog output, initiate the D/A Trim function and connect an ammeter to the loop to measure the actual analog output of the meter. Follow the on-screen functions to complete the task.

Scaled D/A Trim

HART Comm.	1, 4, 3, 1, 5
------------	---------------

Scaled D/A Trim enables you to calibrate the flowmeter analog output using a different scale than the standard 4-20 mA output scale. Non-scaled D/A Trimming (described above), is typically performed using an ammeter where calibration values are entered in units of milliamperes. Both non-scaled D/A trimming and scaled D/A trimming allow you to trim the 4-20mA output to approximately $\pm 5\%$ of the nominal 4mA end point and $\pm 3\%$ of the nominal 20mA end point. Scaled D/A Trimming allows you to trim the flowmeter using a scale that may be more convenient based upon your method of measurement.

For example, it may be more convenient for you to make current measurements by direct voltage readings across the loop resistor. If your loop resistor is 500 Ohms, and you want to calibrate the meter using voltage measurements made across this resistor, you could rescale (select CHANGE on the 275) your trim points from 4-20mA to 4-20mA x 500 ohm or 2-10 VDC. Once your scaled trim points have been entered as 2 and 10, you can now calibrate your flowmeter by entering voltage measurements directly from the voltmeter.

Recall Factory Trim

HART Comm.	1, 4, 3, 1, 6
------------	---------------

Recall Factory Trim enables you to return to the original factory trim values.

Pulse Output

HART Comm.	1, 4, 3, 2
------------	------------

Pulse Output reports the frequency of the pulse output.

NOTE

The HART Communicator will allow configuration of the pulse features even if the pulse option (Option P) was not ordered.

Pulse Output Scale

HART Comm.	1, 4, 3, 2, 1
------------	---------------

The Model 8800C comes with an optional pulse output option (P). This enables the flowmeter to output the pulse rate to an external control system, totalizer, or other device. If the flowmeter was ordered with the pulse mode option, it may be configured for either pulse scaling (based on rate or unit) or shedding frequency output. There are three methods for configuring the pulse output:

- Pulse Scaling — Rate
- Pulse Scaling — Unit
- Direct (Shedding Frequency)

Pulse Scaling – Rate

HART Comm.	1, 4, 3, 2, 1, 1
------------	------------------

This mode allows you to configure the pulse output based on a flow rate. For example, set 100 gallons per minute = 10,000 Hz. (The user enterable parameters are flow rate and frequency.)

1. Enter a flow rate of 100 gallons per minute.
2. Enter a frequency of 10,000 Hz.

Pulse Scaling – Unit

HART Comm.	1, 4, 3, 2, 1, 2
------------	------------------

This mode changes the frequency output to represent the flow rate. If you are using an external totalizer or the frequency output, it may be important to be able to scale the frequency output to familiar terms. The scaled output equates one transistor switch closure pulse to a selectable number of volume units. For example, 1 pulse = 1 gallon.

The pulse output is an isolated switch-closure frequency output signal proportional to flow. The frequency limits are as follows:

- Maximum Frequency = 10,000 Hz
- Minimum Frequency = 0.0000035 Hz (1 pulse/79 hours)
- Duty Cycle = 50%
- For Frequencies ≤ 0.1 Hz the pulse width will equal 5 seconds

Example: Pulse Output Frequency = 0.0333 Hz (1 pulse/30 seconds)

Figure 3-1. Example: The pulse output will maintain a 50 percent duty cycle for all frequencies

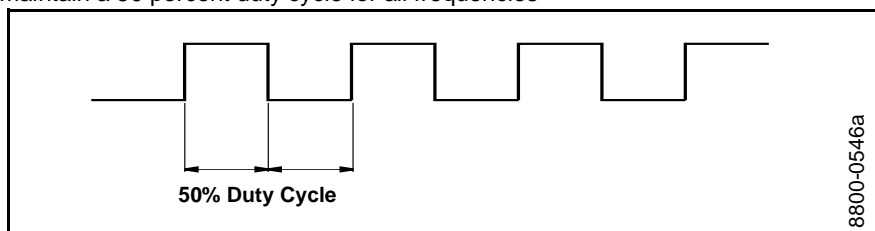

NOTE

The scaled pulse output is designed to operate between 0 and 10,000 Hz. The electronics will not accept a conversion factor that would result in a pulse frequency outside that range. Determine the minimum conversion factor value by dividing the upper range value (in units of volume per second) by 10,000 Hz.

The best choice for this parameter depends on the required resolution, the number of digits in the totalizer, the extent of range required, and the maximum counter input frequency.

Direct (Shedding Frequency)

HART Comm.	1, 4, 3, 2, 1, 3
------------	------------------

This mode provides the vortex shedding frequency as output. In this mode, the software does not compensate the K-factor for effects such as thermal expansion or differing mating pipe inside diameters. Scaled pulse mode must be used to compensate the K-factor for thermal expansion and mating pipe effects.

Pulse Output Test

HART Comm.	1, 4, 3, 2, 2
------------	---------------

Pulse Output Test is a fixed frequency mode test that checks the integrity of the pulse loop. It tests that all connections are good and that pulse output is running on the loop.

HART Output

HART Comm.	1, 4, 3, 3
------------	------------

Multidrop configuration refers to the connection of several flowmeters to a single communications transmission line. Communication occurs digitally between a HART-based communicator or control system and the flowmeters. Multidrop mode automatically deactivates analog output of the flowmeters. Using the HART communications protocol, up to 15 transmitters can be connected on a single twisted pair of wires or over leased phone lines.

The use of a multidrop installation requires consideration of the update rate necessary from each transmitter, the combination of transmitter models, and the length of the transmission line. Multidrop installations are not recommended where intrinsic safety is a requirement. Communication with the transmitters can be accomplished with commercially available Bell 202 modems and a host implementing the HART protocol. Each transmitter is identified by a unique address (1-15) and responds to the commands defined in the HART protocol.

Figure 3-2 shows a typical multidrop network. This figure is not intended as an installation diagram. Contact Rosemount product support with specific requirements for multidrop applications.

Figure 3-2. Typical Multidrop Network

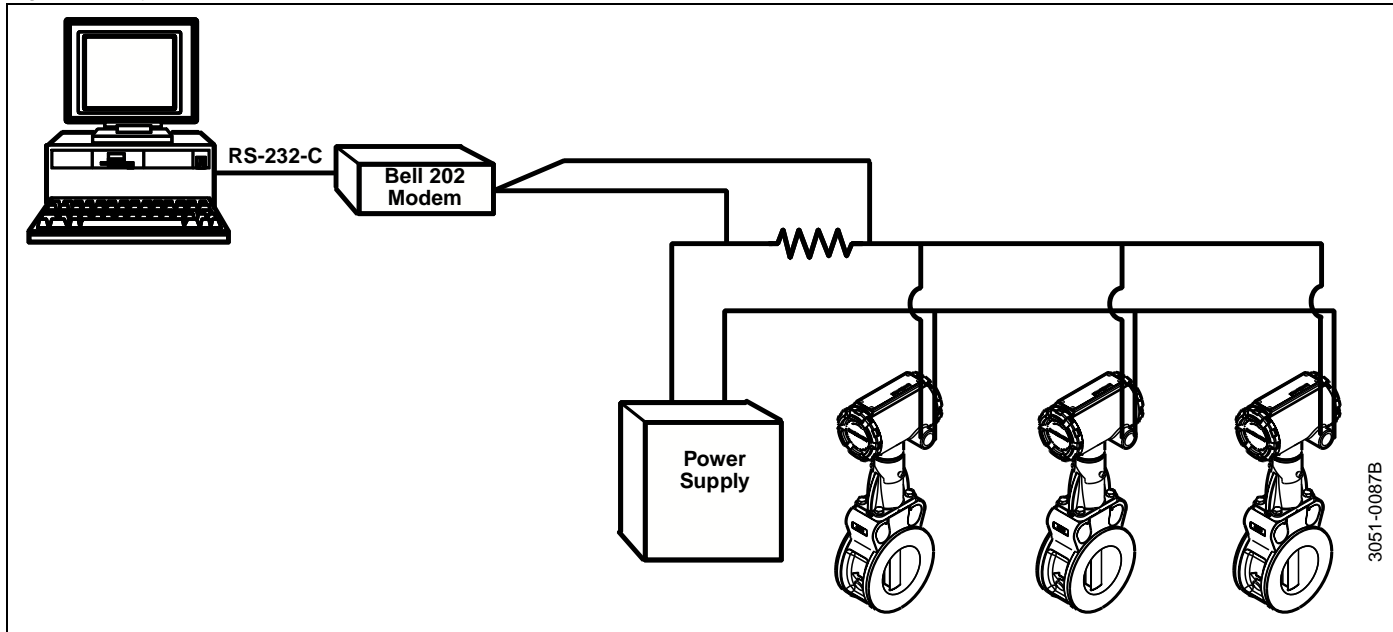

NOTE

The Model 8800C is set to poll address zero at the factory, allowing it to operate in the standard point-to-point manner with a 4–20 mA output signal. To activate multidrop communication, the transmitter poll address must be changed to a number between 1 and 15. This change deactivates the 4–20 mA analog output, setting it to 4 mA, and disables the failure mode alarm signal.

Poll Address

HART Comm.	1, 4, 3, 3, 1
------------	---------------

Poll Address enables you to set the poll address for a multi-dropped meter. The poll address is used to identify each meter on the multi-drop line. Follow the on-screen instructions to set the address at a number from 1 to 15. To set or change the flowmeter address, establish communication with the selected Model 8800C in the loop.

Auto Poll

HART Comm.	OFF LINE FCN
------------	--------------

When a HART-based communicator is powered up and auto polling is on, the communicator automatically polls the flowmeter addresses to which it is connected. If the address is 0, the HART-based communicator enters its normal online mode. If it detects an address other than 0, the communicator finds each device in the loop and lists them by poll address and tag. Scroll through the list and select the meter with which you need to communicate.

If **Auto Poll** is off, the flowmeter must have the poll address set to 0 or the flowmeter will not be found. If a single connected device has an address other than zero and auto polling is off, the device will not be found either.

Burst Mode Configuration

The Model 8800C includes a burst mode function that broadcasts the primary variable or all dynamic variables approximately three to four times a second. The burst mode is a specialized function used in very specific applications. The burst mode function enables you to select the variables to broadcast over the burst mode and to select the burst mode option.

Burst Mode

HART Comm.	1, 4, 3, 3, 3
------------	---------------

The **Burst Mode** variable enables you to set the Burst Mode to the needs of your application. Options for the Burst Mode setting include:

Off—Turns off the Burst Mode so that no data are broadcast on the loop.

On—Turns Burst Mode on so that the data selected under Burst Option are broadcast over the loop.

Additional command options may appear that are reserved and do not apply to the Model 8800C.

Burst Option

HART Comm.	1, 4, 3, 3, 4
------------	---------------

Burst Option enables you to select the variables to broadcast over the burst transmitter. Choose one of the following options:

PV—Selects the process variable for broadcast over the burst transmitter.

Percent Range/Current—Selects the process variable as percent of range and analog output variables for broadcast over the burst transmitter.

Process vars/crnt—Selects the process variables and analog output variables for broadcast over the burst transmitter.

Local Display

HART Comm.	1, 4, 3, 4
------------	------------

The **Local Display** function on the Model 8800C allows you to select which variables are shown on the optional (M5) local display. Choose from the following variables:

- Flow
- Percent of Range
- Output Current
- Total

Signal Processing

HART Comm.	1, 4, 4
------------	---------

The Model 8800C and its HART-based communications feature enable you to filter out noise and other frequencies from the transmitter signal. The four user-alterable parameters associated with the digital signal processing on the Model 8800C include low-pass filter corner frequency, low-flow cutoff, trigger level, and damping. These four signal conditioning functions are configured at the factory for optimum filtering over the range of flow for a given line size and service type (liquid or gas). For most applications, leave these parameters at the factory settings. Some applications may require adjustment of the signal processing parameters.

Use signal processing only when recommended in the Troubleshooting section of this manual. Some of the problems that may require signal processing include:

- High output (output saturation)
- Erratic output with or without flow present
- Incorrect output (with known flow rate)
- No output or low output with flow present
- Low total (missing pulses)
- High total (extra pulses)

If one or more of these conditions exist, and you have checked other potential sources (K-factor, service type, lower and upper range values, 4–20mA trim, pulse scaling factor, process temperature, pipe ID), refer to Section 4: Hardware and Software Maintenance and Troubleshooting procedures. Remember that the factory default settings can be re-established at any time with Filter Restore. If problems persist after signal processing adjustments, consult the factory.

Optimize Flow Range

HART Comm.	1, 4, 4, 1
------------	------------

Optimize Flow Range affects the following variables:

- Flow
- Low Flow Cutoff
- Sig/Tr
- Auto Adjust Filter

Flow

HART Comm.	1, 4, 4, 1, 1
------------	---------------

Flow is the actual measured flow rate in the line. On the bench, the PV value should be zero. Check the units on the PV to make sure they are configured correctly. See PV Units if the units format is not correct. Use the **Process Variable Units** function to select the units for your application.

Low Flow Cutoff

HART Comm.	1, 4, 4, 1, 2
------------	---------------

Low Flow Cutoff is shown in engineering units.

Sig/Tr (Signal/Trigger Level Ratio)

HART Comm.	1, 4, 4, 1, 3
------------	---------------

The **Signal to Trigger Level Ratio** is a variable that indicates the flow signal strength to trigger level ratio. This ratio indicates if there is enough flow signal strength for the meter to work properly. For accurate flow measurement, the ratio should be greater than 4:1. Values greater than 4:1 will allow increased filtering for noisy applications. For ratios greater than 4:1, with sufficient density, the **Auto Adjust Filter** function can be utilized to optimize the measurable range of the flowmeter.

Ratios less than 4:1 may indicate applications with very low densities and/or applications with excessive filtering.

Auto Adjust Filter

HART Comm.	1, 4, 4, 1, 4
------------	---------------

The **Auto Adjust Filter** is a function that can be used to optimize the range of the flowmeter based on the density of the fluid. The electronics uses process density to calculate the minimum measurable flow rate, while retaining at least a 4:1 signal to the trigger level ratio. This function will also reset all of the filters to optimize the flowmeter performance over the new range.

Manual Filter Adjust

HART Comm.	1, 4, 4, 2
------------	------------

Manual Filter Adjust allows you to manually adjust the following settings: Low Flow Cutoff, Low Pass Filter, and Trigger Level, while monitoring flow and or sig/tr.

Flow

HART Comm.	1, 4, 4, 2, 1
------------	---------------

Flow is the actual measured flow rate in the line. On the bench, the PV value should be zero. Check the units on the PV to make sure they are configured correctly. See PV Units if the units format is not correct. Use the **Process Variable Units** function to select the units for your application.

Sig/Tr (Signal/Trigger Level Ratio)

HART Comm.	1, 4, 4, 2, 2
------------	---------------

The **Signal to Trigger Level Ratio** is a variable that indicates the flow signal strength to trigger level ratio. This ratio indicates if there is enough flow signal strength for the meter to work properly. For accurate flow measurement, the ratio should be greater than 4:1. Values greater than 4:1 will allow increased filtering for noisy applications. For ratios greater than 4:1, with sufficient density, the Optimize Flow Range function can be utilized to optimize the measurable range of the flowmeter.

Ratios less than 4:1 may indicate applications with very low densities and/or applications with excessive filtering.

Low Flow Cutoff

HART Comm.	1, 4, 4, 2, 3
------------	---------------

Low Flow Cutoff enables you to adjust the filter for noise at no flow. It is set at the factory to handle most applications, but certain applications may require adjustment either to expand measurability or to reduce noise.

The Low Flow Cutoff offers two modes for adjustment:

- Increase Range
- Decrease No Flow Noise

It also includes a dead band such that once flow goes below the cutoff value, output does not return to the normal flow range until flow goes above the dead band. The dead band extends to approximately 20 percent above the low flow cutoff value. The dead band prevents the output from bouncing between 4mA and normal flow range if the flow rate is near the low flow cutoff value.

Low Pass Filter

HART Comm.	1, 4, 4, 2, 4
------------	---------------

The **Low Pass Filter** sets the low-pass filter corner frequency to minimize the effects of high frequency noise. It is factory set based on line size and service type. Adjustments may be required only if you are experiencing problems. See Section 4: Troubleshooting and Maintenance.

The Low Pass Filter corner frequency variable offers two modes for adjustment:

- Increase filtering
- Increase sensitivity

Trigger Level

HART Comm.	1, 4, 4, 2, 5
------------	---------------

Trigger Level is configured to reject noise within the flow range while allowing normal amplitude variation of the vortex signal. Signals of amplitude lower than the Trigger Level setting are filtered out. The factory setting optimizes noise rejection in most applications. Trigger Level offers two modes for adjustment:

- Increase filtering
- Increase sensitivity

NOTE

Do not adjust this parameter unless directed to do so by a Rosemount Technical Support Representative.

Filter Restore

HART Comm.	1, 4, 4, 3
------------	------------

Filter Restore enables you to return all of the signal conditioning variables to their default values. Should the filter settings get confused, select Filter Restore to restore the default settings and provide a new starting point.

Damping

HART Comm.	1, 4, 4, 4
------------	------------

Damping function changes the response time of the flowmeter to smooth variations in output readings caused by rapid changes in input.

The default damping value is 2.0 seconds. Damping can be reset to any value between 0.2 and 256 seconds.

The appropriate damping setting can be determined based on the necessary response time, signal stability, and other requirements of the loop dynamics in your system.

Process Density

HART Comm.	1, 4, 4, 5
------------	------------

Process Density and **Density Units** are required only if you have designated mass units for your flow rate units. See Process Density on page 3-7 or detailed information.

Device Information

HART Comm.	1, 4, 5
------------	---------

Information variables are used for identification of flowmeters in the field and to store information that may be useful in service situations. Information variables have no effect on flowmeter output or process variables.

Manufacturer

HART Comm.	1, 4, 5, 1
------------	------------

Manufacturer is an informational variable provided by the factory. For the Model 8800C, the Manufacturer is Rosemount.

Tag

HART Comm.	1, 4, 5, 2
------------	------------

Tag is the quickest variable to identify and distinguish between flowmeters. Flowmeters can be tagged according to the requirements of your application. The tag may be up to eight characters long.

Descriptor

HART Comm.	1, 4, 5, 3
------------	------------

Descriptor is a longer user-defined variable to assist with more specific identification of the particular flowmeter. It is usually used in multi-flowmeter environments and provides 16 characters.

Message

HART Comm.	1, 4, 5, 4
------------	------------

The **Message** variable provides an even longer user-defined variable for identification and other purposes. It provides 32 characters of information and is stored with the other configuration data.

Date

HART Comm.	1, 4, 5, 5
------------	------------

Date is a user-defined variable that provides a place to save a date, typically used to store the last date that the transmitter configuration was changed.

Write Protect

HART Comm.	1, 4, 5, 6
------------	------------

Write Protect is a read-only informational variable that reflects the setting of the hardware security switch. If Write Protect is ON, configuration data are protected and cannot be changed from a HART-based communicator or control system. If Write Protect is OFF, configuration data may be changed using the communicator or control system.

Revision Numbers

HART Comm.	1, 4, 5, 7
------------	------------

Revisions Numbers are fixed informational variables that provide the revision number for different elements of your HART Communicator and Model 8800C. These revision numbers may be required when calling the factory for support. Revision numbers can only be changed at the factory and are provided for the following elements:

Universal Rev

HART Comm.	1, 4, 5, 7, 1
------------	---------------

Universal Rev – Designates the HART Universal Command specification to which the transmitter is designed to conform.

Transmitter Rev

HART Comm.	1, 4, 5, 7, 2
------------	---------------

Transmitter Rev – Designates the revision for Model 8800C specific command identification for HART compatibility.

Software Rev

HART Comm.	1, 4, 5, 7, 3
------------	---------------

Software Rev – Designates the internal software revision level for the Model 8800C.

Hardware Rev

HART Comm.	1, 4, 5, 7, 4
------------	---------------

Hardware Rev – Designates the revision level for the Model 8800C hardware.

Final Assembly Number

HART Comm.	1, 4, 5, 7, 5
------------	---------------

Final Assembly Number – Factory set number that refers to the electronics of your flowmeter. The number is configured into the flowmeter for later reference.

Device ID

HART Comm.	1, 4, 5, 7, 6
------------	---------------

Device ID – Factory-defined unique identifier for transmitter identification in the software. Device ID is not user changeable.

Hardware and Software Maintenance and Troubleshooting

Safety Messages	page 4-1
Troubleshooting Tables	page 4-3
Advanced Troubleshooting	page 4-6
Testing Procedures	page 4-9
Hardware Replacement	page 4-10
Return of Material	page 4-27

Table 4-1 provides summarized troubleshooting suggestions for the most common problems that occur during operation. The symptoms of metering problems include:

- Communications problems with a HART-based communicator.
- Incorrect 4–20 mA output.
- Incorrect pulse output.
- Error messages on HART-based communicator.
- Flow in pipe but no transmitter output.
- Flow in pipe with incorrect transmitter output.
- Output with no actual flow.

NOTE

The Model 8800C sensor is extremely reliable and should not have to be replaced. Please consult the factory **before** removing the sensor.

SAFETY MESSAGES

Instructions and procedures in this section may require special precautions to ensure the safety of the personnel performing the operations. Please refer to the following safety messages before performing any in this section.

⚠ WARNING

Explosions could result in death or serious injury:

- Do not remove the transmitter cover in explosive atmospheres when the circuit is alive.
- Before connecting a HART-based communicator in an explosive atmosphere, make sure the instruments in the loop are installed in accordance with intrinsically safe or non-incendive field wiring practices.
- Verify that the operating atmosphere of the transmitter is consistent with the appropriate hazardous locations certifications.
- Both transmitter covers must be fully engaged to meet explosion-proof requirements.

⚠ WARNING

Failure to follow these installation guidelines could result in death or serious injury:

- Make sure only qualified personnel perform the installation.

⚠ CAUTION

The sensor cavity could contain line pressure if an abnormal failure has occurred inside the meter body. Depressurize flow line before removing the sensor nut.

TROUBLESHOOTING TABLES

The most common problems experienced by users of the Model 8800C are listed in Table 4-1 along with potential causes of the problem and suggested corrective actions. See Advanced Troubleshooting on page 4-6 if the problem you are experiencing is not listed here.

Table 4-1. Basic Troubleshooting - Model 8800C Smart Vortex Flowmeter

Symptom	Corrective Action
Communication problems with HART-based Communicator	<ul style="list-style-type: none"> • Check for a minimum of 12 V dc at transmitter terminals. • Check communications loop with HART-based communicator. • Check for loop resistor (250 to 1000 ohms). • Check for transmitter in multidrop mode.
Incorrect 4–20 mA Output	<ul style="list-style-type: none"> • Check for 12 V dc at transmitter terminal. • Check URV, LRV, Density, Special Units, LFC—compare these inputs with the sizing program results. Correct configuration. • Perform 4–20 mA loop test.
Incorrect Pulse Output	<ul style="list-style-type: none"> • Check that 4–20 mA output is correct. • Check pulse counter specifications. • Check pulse mode and scaling factor. (Make sure scaling factor is not inverted).
Error Messages on HART-based Communicator	<ul style="list-style-type: none"> • See alphabetical listing in the Error Messages Table for the communicator in Appendix C: HART Communicator.
Flow in Pipe, No Output	<p>Basics</p> <ul style="list-style-type: none"> • Check to make the sure that the meter is installed with the arrow in the direction of process flow. • Perform basic checks for Incorrect 4–20 mA Output Problem (see Incorrect 4–20 mA Output). • Check and correct configuration parameters in this order: K-factor, service type, materials, units, process temperature, damping value, 4–20 mA trim, meter body number, density, pulse mode, pulse scaling, line size, pipe diameter, LRV, URV, LP corner, trigger level, low flow cutoff. • Check sizing. Make sure flow is within measurable flow limits. • Refer to Advanced Troubleshooting on page 4-6. • See Appendix E: Electronics Verification for electronics verification procedure. <p>Electronics</p> <ul style="list-style-type: none"> • Run a self test with the Model 268/HART Communicator. • Using sensor simulator, insert test signal. • Check configuration, LFC, trigger level, STD vs. actual flow. • Replace electronics. <p>Application Problems</p> <ul style="list-style-type: none"> • Calculate expected frequency (see Appendix E: Electronics Verification). If actual frequency is the same, check configuration. • Check that application meets viscosity and specific gravity requirements for the line size. • Recalculate back pressure requirement. If necessary and possible, increase back pressure, flow rate, or operating pressure. <p>Sensor</p> <ul style="list-style-type: none"> • Check torque on sensor nut (32 ft-lb). • Inspect coaxial sensor cable for cracks. Replace if necessary. • Check that sensor impedance >10 Megohms. Replace sensor if necessary (Replacing the Sensor on page 4-15). • Measure sensor capacitance at SMA connector (100–200pF).

Rosemount Model 8800C Vortex Flowmeter

Symptom	Corrective Action
<p>Flow in Pipe, Incorrect Output</p>	<p>Basics</p> <ul style="list-style-type: none"> • Perform basic checks for Incorrect 4–20 mA Output Problem (see Incorrect 4–20 mA Output on page 4-3). • Check and correct configuration parameters in this order: K-factor, service type, materials, units, process temperature, damping value, 4–20 mA trim, meter body number, density, pulse mode, pulse scaling, line size, pipe diameter, LRV, URV, LP corner, trigger level, and low flow cutoff. • Check sizing. Make sure flow is within measurable flow limits. • Refer to Advanced Troubleshooting on page 4-6. • See Appendix E: Electronics Verification for electronics verification procedure. <p>Application Problems</p> <ul style="list-style-type: none"> • Calculate expected frequency. If actual frequency is the same, check configuration. • Check to make sure the meter is not installed backwards (Arrow on meter pointing upstream is backwards). Re-install the meter if necessary. • Check that application meets viscosity and specific gravity requirements for the line size. • Recalculate back pressure requirement. If necessary and possible, increase back pressure, flow rate, or operating pressure. • Check for gasket or other obstruction disturbing flow. Reinstall meter if necessary. • Pump pulsations disturbing flow. Adjust signal processing parameters. <p>Vibration Problem</p> <ul style="list-style-type: none"> • Adjust signal processing parameters. • Rotate meter 90 degrees. • Add support to the line near the meter to damp the vibration. <p>When the vortex meter is set for gas or steam service and the vibration levels are greater than ½ g, the Low Flow Cutoff value (LFC) may need to be increased to eliminate undesirable output at no flow conditions. The level of LFC increase depends on the vibration level and meter size. LFC is unique for each application. When flow begins, the flow signal becomes much larger than the vibration signal and the meter will lock onto the flow signal and give an accurate flow output.</p> <p>50/60 Hz Measurement</p> <ul style="list-style-type: none"> • Make sure electronics mounting screws (3) are securely installed. • May indicate electrical or magnetic interference. Check meter ground. Measure voltage levels between 4–20 mA and pulse outputs and the electronics housing. Common mode voltage < 30 Vrms. • If the meter is located near a large motor or electric furnace try different meter orientations to reduce the noise. Magnetic fields must be less than 5 gauss. • In remote mount installations, try integral mount to see if problem is corrected. Measure ac voltage from electronics housing to SMA connector. The voltage must be <1Vrms. <p>Sensor</p> <ul style="list-style-type: none"> • Sensor should resist removal because the interference fit has extremely tight tolerances. Repeated removal and installation of the sensor will loosen it. If sensor is loose, replace the sensor. • Inspect and tighten sensor connector if necessary. • Inspect coaxial sensor cable for cracks. Replace if necessary. • Check torque on sensor nut (32 ft-lb). • Check that sensor impedance >10 Megohms. Replace sensor if necessary (see Replacing the Sensor on page 4-15). • Measure sensor capacitance at SMA connector. (100–200pF)

Symptom	Corrective Action	
Output with No Actual Flow	<p>Basics</p> <ul style="list-style-type: none"> • Perform basic checks for Incorrect 4–20 mA Output Problem (see Incorrect 4–20 mA Output on page 4-3). • Check and correct configuration parameters in this order: K-factor, service type, materials, units, process temperature, damping value, 4–20 mA trim, meter body number, density, pulse mode, pulse scaling, line size, pipe diameter, LRV, URV, LP corner, trigger level, low flow cutoff. • Check sizing. Make sure flow is within measurable flow limits. • Using a HART-based communicator, read the shedding frequency. • Refer to Advanced Troubleshooting on page 4-6. <p>Vibration Problem</p> <ul style="list-style-type: none"> • Adjust signal processing parameters: <i>Adjust low flow cutoff to higher flow rates (if the application allows). Move the low flow cutoff up one notch and measure the process variable. Continue moving the low flow cutoff until the problem is corrected or the flow range is too limited for the application. Adjust the trigger level up; the default trigger level is four. Adjust it one notch and measure the process variable. Continue moving the trigger level until the output reaches zero or the trigger level reaches a value of seven. Be sure to check the process variable with the process flowing once you are done adjusting the trigger level.</i> • Rotate the meter 90 degrees. • Add support to the line near the meter to damp the vibration. 	<p>50/60 Hz Measurement</p> <ul style="list-style-type: none"> • Make sure electronics mounting screws (3) are securely installed. • May indicate electrical or magnetic interference. Check meter ground. Measure voltage levels between 4–20 mA and pulse outputs and the electronics housing. Common mode voltage <30 Vrms. • If the meter is located near a large motor or electric furnace try different meter orientations to reduce the noise. Magnetic fields must be less than 5 gauss. • In remote mount installations, try integral mount to see if problem is corrected. Measure ac voltage from electronics housing to SMA connector. The voltage must be <1Vrms. <p>Application Problems</p> <ul style="list-style-type: none"> • Pump pulsations disturbing flow. Adjust signal processing parameters. • Add flow straightener. • Check all valves and make sure they are closed.

ADVANCED TROUBLESHOOTING

The Model 8800C electronics provides several advanced troubleshooting features. These features enhance your ability to look inside the electronics and can be helpful for troubleshooting inaccurate readings. As shown in Figure 4-1, there are several test points located on the electronics.

Figure 4-1. Electronics Test Points

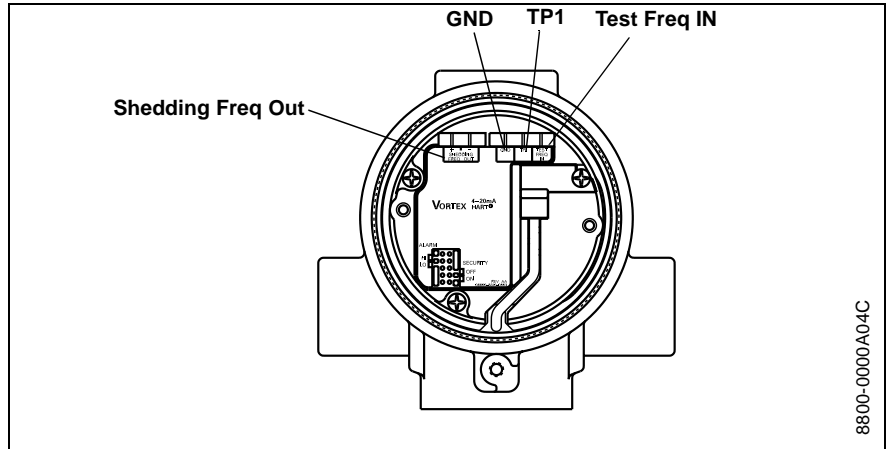

A digital representation of the filtered sensor shedding frequency is available on the “SHEDDING FREQ OUT” pins shown in Figure 4-1. The electronics are capable of internally generating a flow signal that may be used to simulate a sensor signal to perform electronics verification with the Model 275 or AMS interface. The simulated signal amplitude is based on the transmitter required minimum process density. The signal being simulated can be one of several profiles – a simulated signal of constant frequency or a simulated signal representative of a ramping flow rate. The electronics verification procedure is described in detail in Appendix E: Electronics Verification. To verify the electronics, you can input a frequency on the “TEST FREQ IN” and “GND” pins to simulate flow via an external signal source such as a frequency generator. To analyze and/or troubleshoot the electronics, an oscilloscope (set for AC coupling) and a Model 275 or AMS interface are required. Figure 4-2 is a block diagram of the signal as it flows from the sensor to the microprocessor in the electronics.

Figure 4-2. Signal Flow

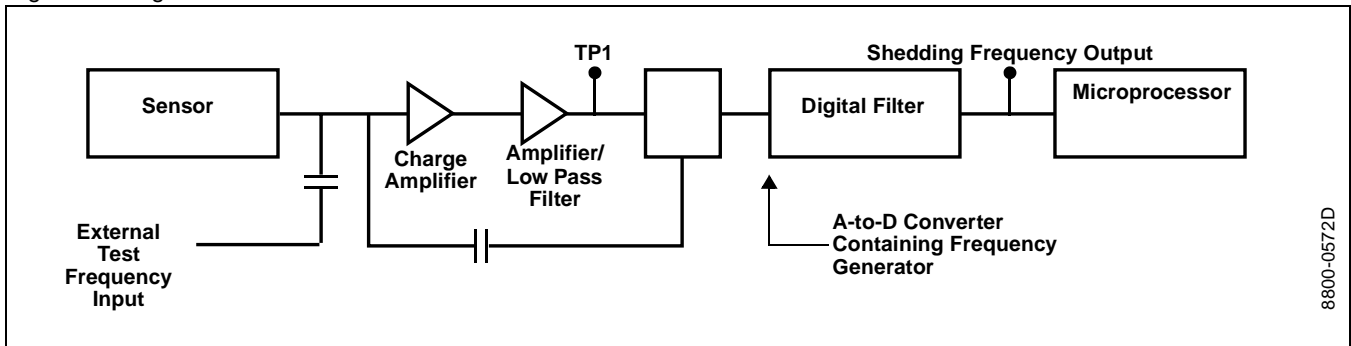

TP1

TP1 is the vortex shedding signal after it has gone through the charge amplifier and low pass filter stages and into the input of the sigma delta A-to-D converter ASIC in the electronics. The signal strength at this point will be in the mV to Volt range.

TP1 is easily measured with standard equipment.

Figures 4-3, 4-4, and 4-5 show ideal (clean) waveforms and waveforms that may cause the output to be inaccurate. Please consult the factory if the waveform you detect is not similar in principle to these waveforms.

Rosemount Model 8800C Vortex Flowmeter

Figure 4-3. Clean Signals

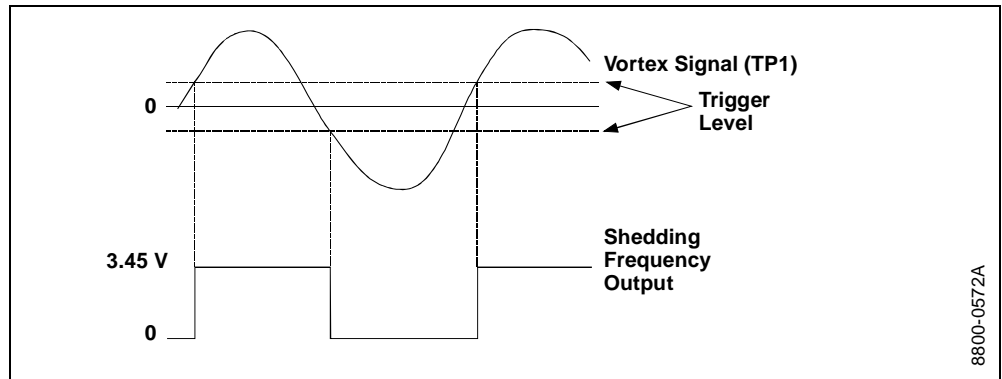

Figure 4-4. Noisy Signals

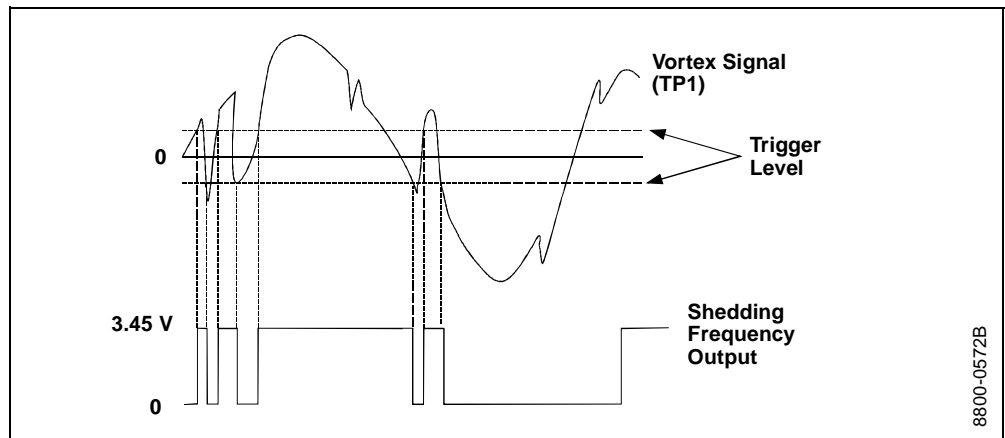
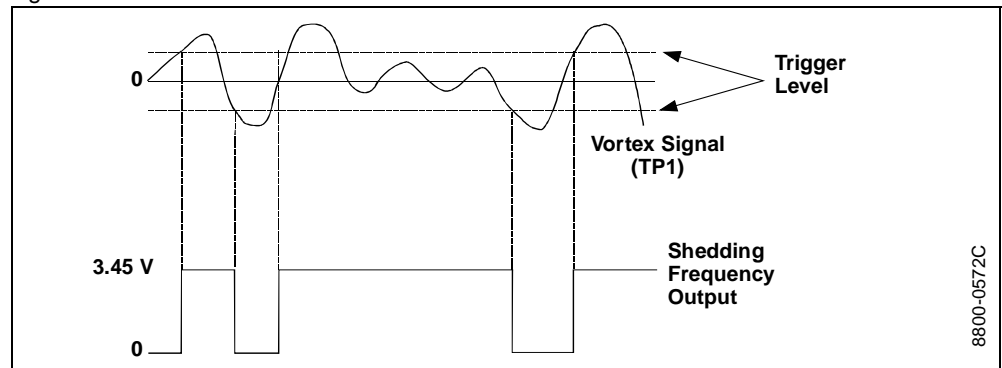

Figure 4-5. Improper Sizing/Filtering



Shedding Frequency Out

Shedding frequency out is probably the easiest point to measure and interpret. It is the final waveform after all filtering has taken place. It is the flow signal that is sent to the microprocessor to be processed into outputs. Check this point first, as it will allow you to see the final waveform (after filtering) before it goes to the microprocessor.

Symptom	Basics	Corrective Action
Clean Signals at TP1 and Shedding Frequency Out, But Incorrect Output	<p>Basics</p> <ul style="list-style-type: none"> • Perform basic checks for incorrect 4–20 mA output problem (see Basic Troubleshooting - Model 8800C Smart Vortex Flowmeter on page 4-3). • Perform basic check for pulse output. • Check and correct configuration parameters in this order: K-factor, service type, materials, units, process temperature, damping value, 4–20 mA trim, filter tracking, density, density ratio, pulse mode, pulse scaling, line size, pipe diameter, LRV, URV, LP corner, trigger level, and low flow cutoff. 	<ul style="list-style-type: none"> • Refer to Advanced Troubleshooting on page 4-6. • See Appendix E: Electronics Verification for electronics verification procedure. • Refer to Table 4-1 for further troubleshooting.
No Pulse at Shedding Frequency Out	<p>Basics</p> <ul style="list-style-type: none"> • Check TP1. • Check electronics via Flow Simulation Mode (see Appendix E: Electronics Verification). • Check electronics with frequency external generator (see Appendix E: Electronics Verification). 	<ul style="list-style-type: none"> • Check that sensor impedance >10 Megohms. Replace sensor if necessary. (See Replacing the Sensor on page 4-15.) • Measure sensor capacitance at SMA connector (100–200pF).
Noisy Signal at Shedding Frequency Out	<p>Basics</p> <ul style="list-style-type: none"> • Simulate signal with frequency generators or Flow Simulation Mode (see Appendix E: Electronics Verification). 	<ul style="list-style-type: none"> • Optimize filter (gas); increase filtering of low pass filter. • Consult factory.
Missing Pulses at Shedding Frequency Out	<p>Basics</p> <ul style="list-style-type: none"> • Low back pressure. • Viscosity too high. • Density too low. 	<ul style="list-style-type: none"> • Check sensor. • Too much filtering. Check signal/trigger level.

TESTING PROCEDURES

Use the test functions to verify that the flowmeter is functioning properly, or when you suspect component failure or a problem with loop performance, or when instructed to do so as part of a troubleshooting procedure. Initiate each test with the HART Communicator or other HART-based communications device. See Diagnostics/Service on page 3-3 for details.

HARDWARE REPLACEMENT

The following procedures will help you disassemble and assemble the Model 8800C hardware if you have followed the troubleshooting guide earlier in this section of the manual and determined that hardware components need to be replaced.

NOTE

Failure of the Model 8800 housing, electronics, terminal block, LCD indicator, or entire assembly requires replacement with the Model 8800C housing, electronics, terminal block and optional LCD indicator. The Model 8800 can be identified on the SST tag or by visually checking to see if the conduit entries are on the top of the housing. See Replacing the Electronics Housing on page 4-13, for further information.

NOTE

Use only the procedures and new parts specifically referenced in this manual. Unauthorized procedures or parts can affect product performance and the output signal used to control a process, and may render the instrument dangerous. Direct any questions concerning these procedures or parts to Rosemount Inc.

NOTE

Flowmeters should not be left in service once they have been determined to be inoperable.



NOTE

Process should be vented before the meter body is removed from service for disassembly.

Replacing the Terminal Block in the Housing

To replace the Field Terminal Block in the housing, you will need a small, flat head screwdriver. Use the following procedure to replace the terminal block in the housing of the Model 8800C.



NOTE

Remove power before removing the electronics cover.

Remove the Terminal Block

1. Turn off the electric power to the Model 8800C.
2. Unscrew the cover.

Figure 4-6. Terminal Block Assembly

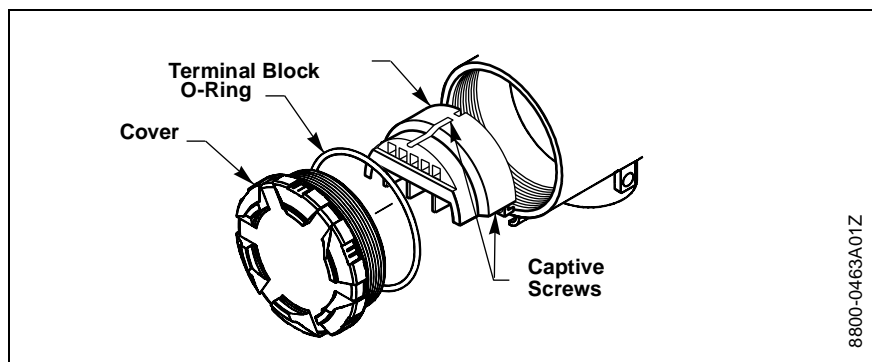

3. Disconnect the wires from the field terminals. Be sure to secure them out of the way.
4. Remove the ground screw (middle of the terminal block) if transient protection (Option T1) is installed.
5. Loosen the captive screws.
6. Pull outward on the block to remove it from the housing.

Install the Terminal Block

1. Align the terminal block over the captive screw holes in the terminal block side of the electronics housing.
2. Slowly press the terminal block into place. Do not force the block into the housing. Check the screw alignment if it does not glide into place.
3. Tighten the three captive screws to anchor the terminal block.
4. Connect the wires to the appropriate field terminals.
5. Reinstall and tighten the transient ground screw if you have the transient option (Option T1).
6. Screw on and tighten the cover.



See Safety Messages on page 4-1 for complete warning information.

Replacing the Electronics Boards

The Model 8800C electronics boards may need to be replaced if they have been damaged or otherwise become dysfunctional. Use the following procedures to replace electronics boards in the Model 8800C. You will need a small flat head screwdriver and pliers.

NOTE

The electronics boards are electrostatically sensitive. Be sure to observe handling precautions for static-sensitive components.



NOTE

Remove power before removing the electronics cover.

Remove the Electronics Boards

1. Turn off the electric power to the Model 8800C.
2. Unscrew and remove the electronics board compartment cover. (Unscrew and remove the LCD cover if you have the LCD option).

Figure 4-7. Electronics Boards Assembly

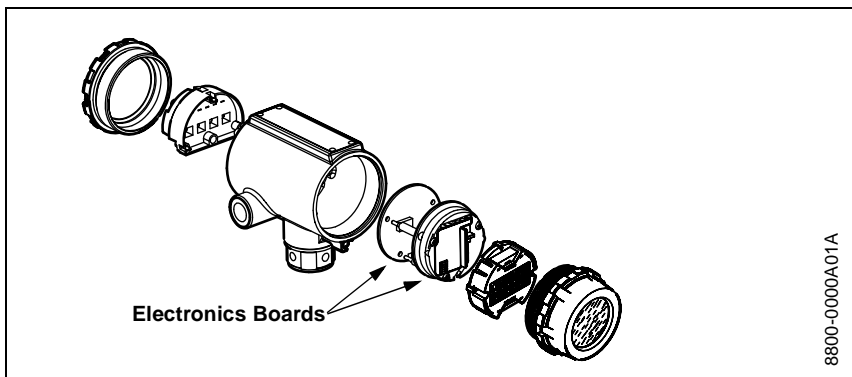

3. If the meter has the LCD indicator option, loosen the two screws. Remove the LCD and the connector from the electronics board.
4. Loosen the three captive screws that anchor the electronics.
5. Use pliers to carefully remove the sensor cable clip from the electronics.
6. Use the two screw heads on the right- and left-hand sides of the board to slowly pull the electronics boards out of the housing.



See "Safety Messages" on page 4-1 for complete warning information.

Install the Electronics Boards

1. Verify that electric power to the Model 8800C is off.
2. Align the two electronics boards over the captive screw holes in the housing.
3. Slowly press the boards into place. Do not force the boards down. Check the screw alignment if they do not glide into place.
4. Use extreme caution to insert sensor cable clip into the electronics board.
5. Tighten the captive screws to anchor the two electronics boards.
6. Reinsert jumpers into proper location.
7. If the meter has LCD option, insert the connector header into the LCD board.
 - Put the connector through the bezel on the electronics board set.
 - Carefully press the indicator onto the connector.
 - Tighten the two screws that retain the LCD indicator.
 - Insert the alarm and security jumpers in the correct location.
8. Replace the electronics board compartment cover.

Replacing the Electronics Housing

The Model 8800C electronics housing can be replaced easily when necessary. Use the following procedure:

Tools Needed

- $\frac{5}{32}$ -inch (4 mm) hex wrench
- $\frac{5}{16}$ -inch open end wrench
- Screwdriver to disconnect wires
- Tools to disconnect conduit



NOTE

Remove power before removing the electronics housing.

Remove the Electronics Housing

1. Turn off the electric power to the Model 8800C.
2. Disconnect the wires and conduit from the housing.
3. Loosen the screw on the access cover (on the support tube). See Figure 4-8.
4. Remove the access cover.

Rosemount Model 8800C Vortex Flowmeter

Figure 4-8. Electronics Housing Access Cover

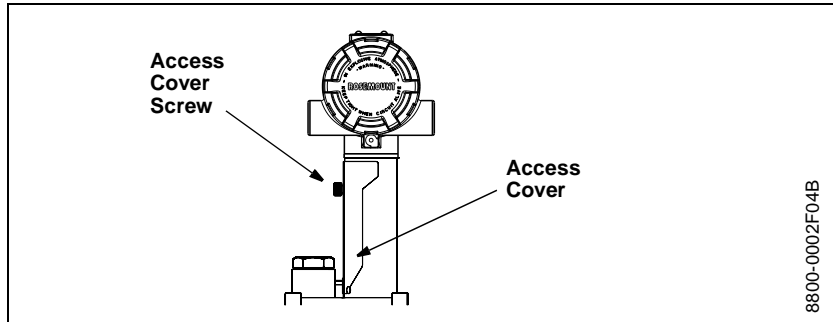

5. Use a hex wrench to loosen the housing rotation screws (at the base of the electronics housing) by turning screws clockwise (inward) until they will clear the bracket.

Figure 4-9. Housing Rotation Screws

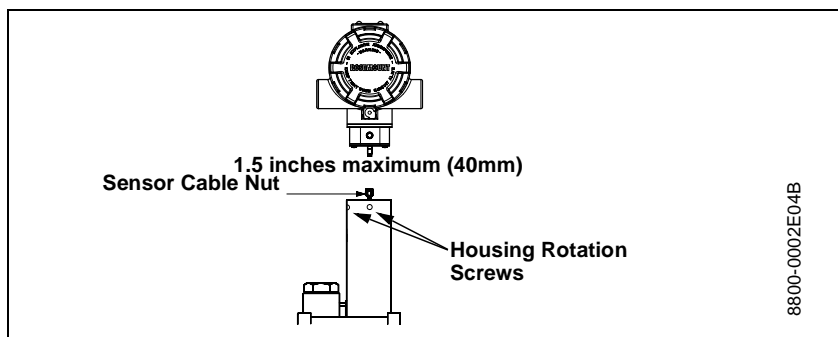

6. Slowly pull the electronics housing no more than 1.5 inches from the top of the support tube.
7. Loosen the sensor cable nut from the housing with a $\frac{5}{16}$ -inch open end wrench. See Figure 4-9.

NOTE

Lift the electronics housing until the sensor cable is disconnected. Do not pull the housing more than 1.5 inches (40 mm) from the top of the support tube. Damage to the sensor may occur if this sensor cable is stressed.

Install the Electronics Housing

1. Verify that power to the Model 8800C is off.
2. Screw the sensor cable onto the base of the housing.
3. Tighten the sensor cable with a $\frac{5}{16}$ -inch open end wrench.
4. Place the electronics housing into the top of the support tube.
5. Tighten the housing rotation screws with a hex wrench.
6. Place the access cover on the support tube.
7. Tighten the screw on the access cover.
8. Connect conduit and wires.
9. Apply power.

Replacing the Sensor

The sensor for the Model 8800C is a sensitive instrument that should not be removed unless there is a problem with it. If you must replace the sensor, follow these procedures closely. **Please consult the factory before removing the sensor.**

NOTES

Be sure to fully check all other troubleshooting possibilities before removing the sensor.

Do not remove the sensor unless it is determined that a problem exists with the sensor itself. The sensor may not fit on the post if it is removed and replaced more than two or three times, or replaced incorrectly.

Also, please note that the sensor is a complete assembly and cannot be further disassembled.

Tools Needed

- $\frac{5}{32}$ -inch (4 mm) hex wrench
- $\frac{5}{16}$ -inch open end wrench
- $\frac{7}{16}$ -inch open end wrench
- $\frac{3}{4}$ -inch open end wrench (for 3- and 4-inch [80 and 100 mm] SST wafers)
- $1\frac{1}{8}$ -inch open end wrench (for all other models)
- Suction or compressed air device
- Small, soft bristle brush
- Cotton swabs
- Appropriate cleaning liquid: water or cleaning agent

There are two support tubes for the Model 8800C. The removable support tube is for wafer meters $\frac{1}{2}$ - through 4-inch (15 through 100 mm) and all flanged meters. The integral support tube is for 6- and 8-inch (150 and 200 mm) wafer meters. The procedure for replacing the sensor contains details for both the removable and integral support tubes.

Sensor Compatibility Guide

1. Determine the sensor serial number. The sensor serial number is located on the top of the sensor.
2. Verify meter body number designator as either “none”, “A”, or “B”. The body number is found on the meter body tag.
Ex. 101467, 101467A, or 101467B.

Meter body designators:

none = welded body with sensor s/n < 30000.

A = welded body with sensor s/n ≥ 30000.

B = integral cast body with sensor s/n ≥ 30000.

3. Using a Model 275 HART communicator, verify the electronics software revision. Use HART fast key 1,4,5,7,3.
4. With the information obtained from steps 1, 2, and 3, use the table below to make the necessary adjustments.

Sensor Serial Number	Meter Body Designator	Electronics Model 8800 ⁽¹⁾	Electronics Model 8800A Software Rev 3 or 4 ⁽²⁾	Electronics Model 8800A Software Rev 5 ⁽³⁾
< 30000	None or A	No adjustment necessary.	No adjustment necessary.	Enter meter body designator “none” into electronics.
	B	Not Compatible. Purchase new sensor.	Not Compatible. Purchase new sensor.	Not Compatible. Purchase new sensor.
≥ 30000	None or A	Move low pass filter one step from default to a LOWER frequency.	Move low pass filter one step from default to a LOWER frequency.	Enter meter body designator “A” into electronics.
	B	No adjustment necessary.	No adjustment necessary.	Enter meter body designator “B” into electronics.

(1) To enter low pass filter adjustment into Model 8800 electronics, use HART fast key sequence 1,4,2,5,3.

(2) To enter low pass filter adjustment into rev 3 or 4 electronics, use HART fast key sequence 1,4,4,2,4.

(3) To enter meter body designator into rev 5 electronics, use HART fast key sequence 1,4,1,4.

Replacing the Sensor: Removable and Integral Support Tubes

The following procedure applies to flowmeters equipped with a removable support tube, i.e. all flanged meters and 1/2- through 4-inch (DN 15 through 100) wafer meters.

1. De-pressurize the flow line.



NOTE

Sensor cavity could contain line pressure if an abnormal failure has occurred inside the meter body. De-pressurize flow line before removing the sensor nut.

2. Remove the electronics housing (see Replacing the Electronics Housing on page 4-13).
 - For meters with a removable support tube (1/2- to 4-in. [15 to 100 mm] wafer meters and all flanged meters), follow steps 3-5.

Removable Support Tube (for 1/2- to 4-in. wafer meters and all flanged meters)

3. Loosen the four support tube anchor bolts with a 7/16-inch open end wrench. See Figure 4-10.
4. Remove the support tube.

Figure 4-10. Removable Support Tube Assembly

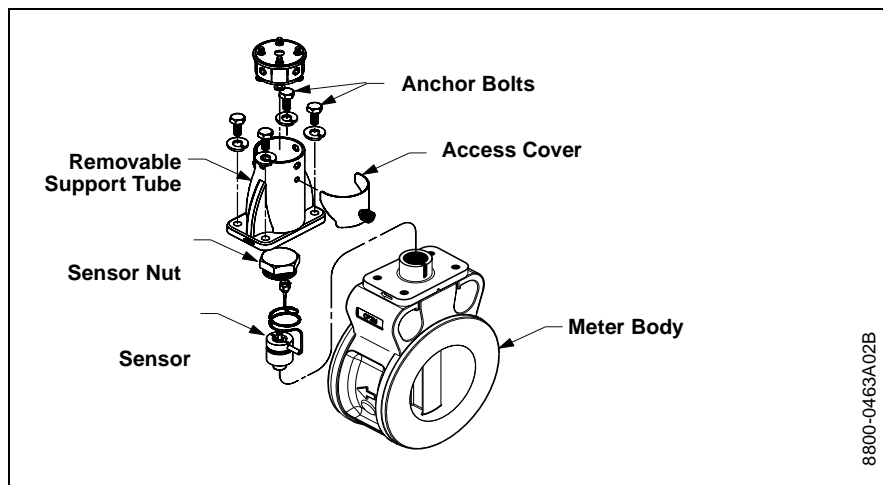

5. Proceed to step 8.
 - For meters with an integral support tube, (6- to 8-in. [100 to 200 mm] wafer meters), follow steps 6-7.



See Safety Messages on page 4-1 for complete warning information.

Integral Support Mount (for 6- to 8-in. wafer meters)

6. Remove access cover. See Figure 4-11.

Figure 4-11. Integral Support Tube Assembly

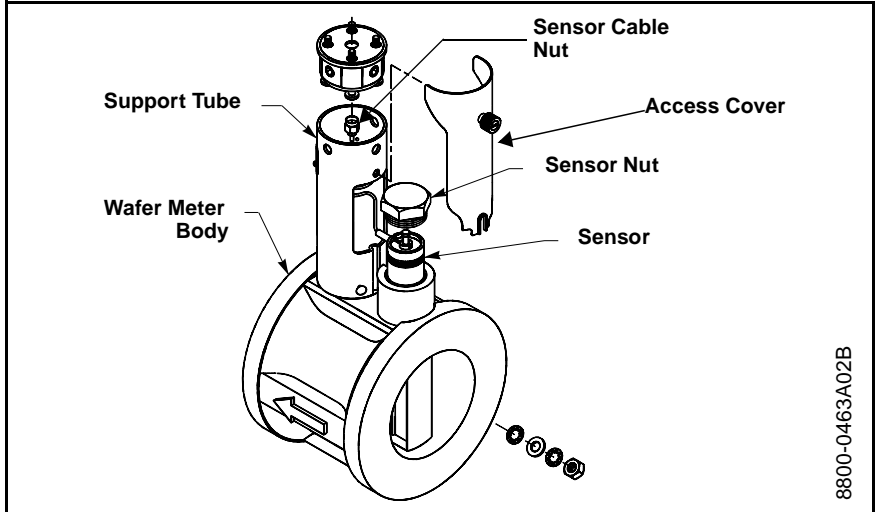

7. Proceed to step 8.
8. Loosen and remove the sensor nut from the sensor cavity with a 1¹/₈-inch open end wrench. (Use a 3³/₄-inch open end wrench for 3- and 4-inch [80 and 100 mm] SST wafers.)
9. Lift the sensor from the sensor cavity. Be very careful to lift the sensor straight up. Do not rock, twist, or tilt the sensor during removal; this will damage the engagement diaphragm.

Cleaning the Sealing Surface

Before installing a sensor in the meter body, clean the sealing surface by completing the following procedure. The metal o-ring on the sensor is used to seal the sensor cavity in the event that process fluid should corrode through the meter body and enter the sensor cavity. Be sure not to scratch or otherwise damage any part of the sensor, sensor cavity, or sensor nut threads. Damage to these parts may require replacement of the sensor or meter body, or may render the flowmeter dangerous.

NOTE

If you are installing a sensor that has been used before, clean the metal o-ring on the sensor using the procedure above. If you are installing a newly purchased sensor, cleaning the o-ring is not necessary.

1. Use a suction or compressed air device to remove any loose particles from the sealing surface and other adjacent areas in the sensor cavity.

NOTE

Do not scratch or deform any part of the sensor, sensor cavity, or sensor nut threads.

2. Carefully brush the sealing surface clean with a soft bristle brush.
3. Moisten a cotton swab with an appropriate cleaning liquid.
4. Wipe the sealing surface. Repeat several times if necessary with a clean cotton swab until there is minimal dirt residue picked up by the cotton swab.

Figure 4-12. O-Ring Sealing Surface in Sensor Cavity

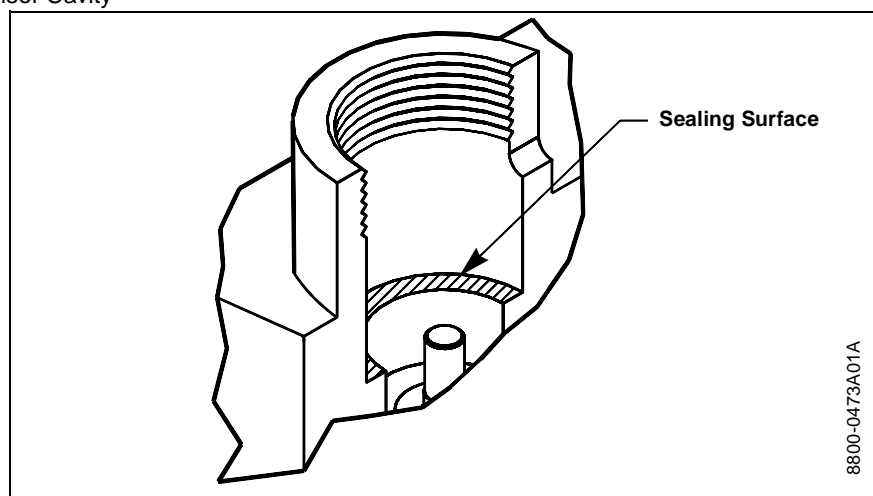

Sensor Installation

1. Carefully place sensor over the post in the sensor cavity.
2. Insure that the sensor is centered on the post. See Figure 4-13 for an example of improper installation and Figure 4-14 for an example of proper installation.

Rosemount Model 8800C Vortex Flowmeter

Figure 4-13. Sensor Installation – Improper Alignment

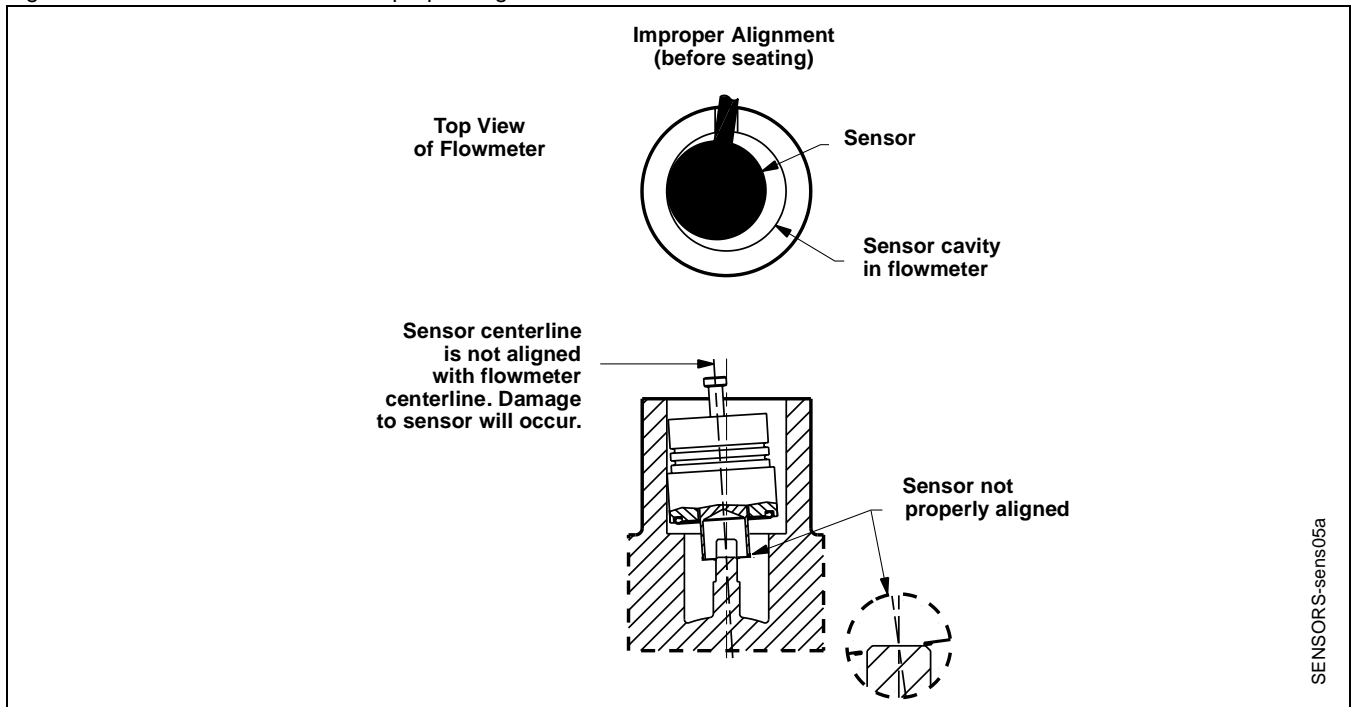
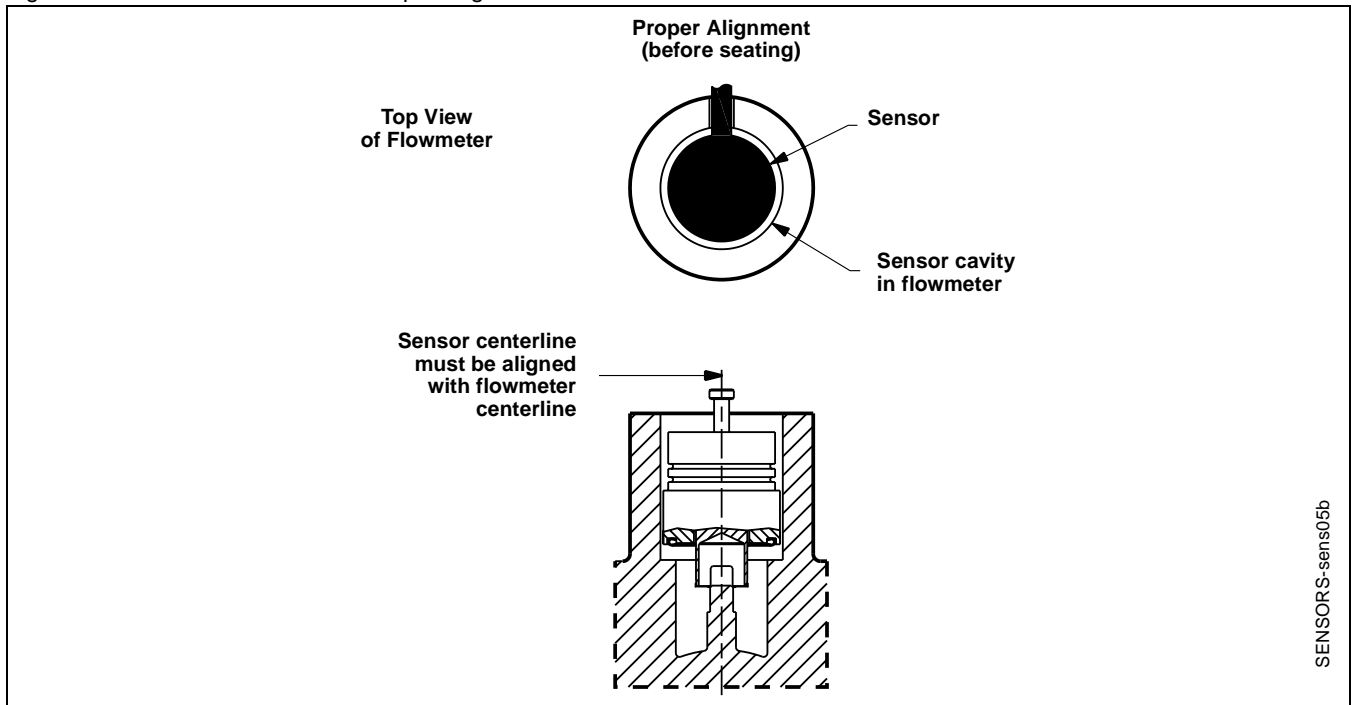
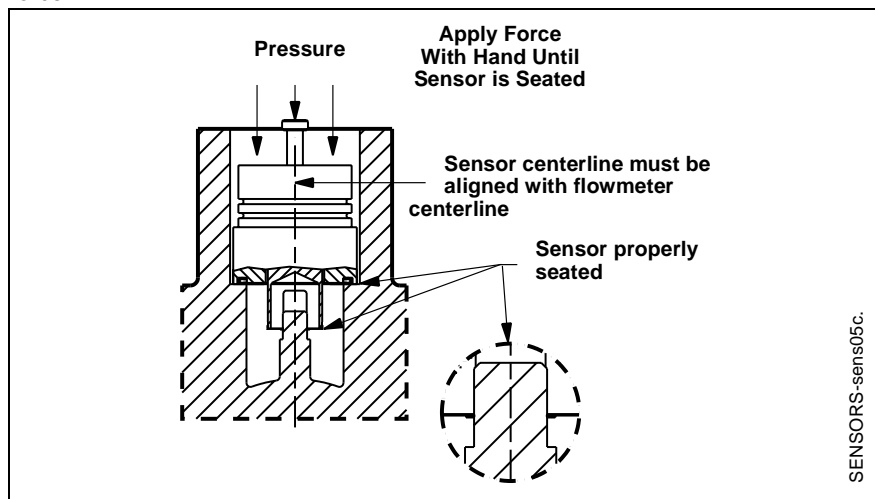

Figure 4-14. Sensor Installation – Proper Alignment



3. Sensor should remain as close to vertical as possible when applying force to seat. See Figure 4-15.

Figure 4-15. Sensor Installation – Applying Force



4. Manually push down on the sensor by applying equal pressure for engagement onto the post.
5. Screw the sensor nut into the sensor cavity. Tighten the nut with a 1/8-inch open end torque wrench to 32 ft-lbs. (Use a 3/4-inch open end wrench for 3- and 4-inch [80 and 100 mm] SST wafers).

NOTE

The sensor nut must be tightened to 32 ft-lbs. for accurate flowmeter operation.

6. Replace the support tube.
7. Tighten the four bolts that anchor the support tube in place with a 7/16-inch open end wrench.
8. Install the flowmeter electronics housing. See Install the Electronics Housing on page 4-15.

Remote Electronics Procedure

If the Model 8800C electronics housing is mounted remotely, some replacement procedures are different than for the flowmeter with integral electronics. The following procedures are exactly the same:

- Replacing the Field Terminal Block (see page 4-11).
- Replacing the Electronics Boards (see page 4-12).
- Replacing the Sensor (see page 4-15).

To disconnect the coaxial cable from the meter body and electronics housing, follow the instructions below.

Disconnect the Coaxial Cable at the Meter

1. Remove the access cover on the meter body support tube.
2. Loosen the three housing rotation screws at the base of the electronics housing with a hex wrench by turning the screws clockwise (inward) until they will clear the bracket.
3. Loosen and remove the sensor cable nut from the union using a $\frac{9}{16}$ -inch open end wrench.

NOTE

Do not pull the adaptor more than 1.5 inches (40 mm) from the top of the support tube. Damage to the sensor may occur if the sensor cable is stressed.

Figure 4-16. Coaxial Cable Connections

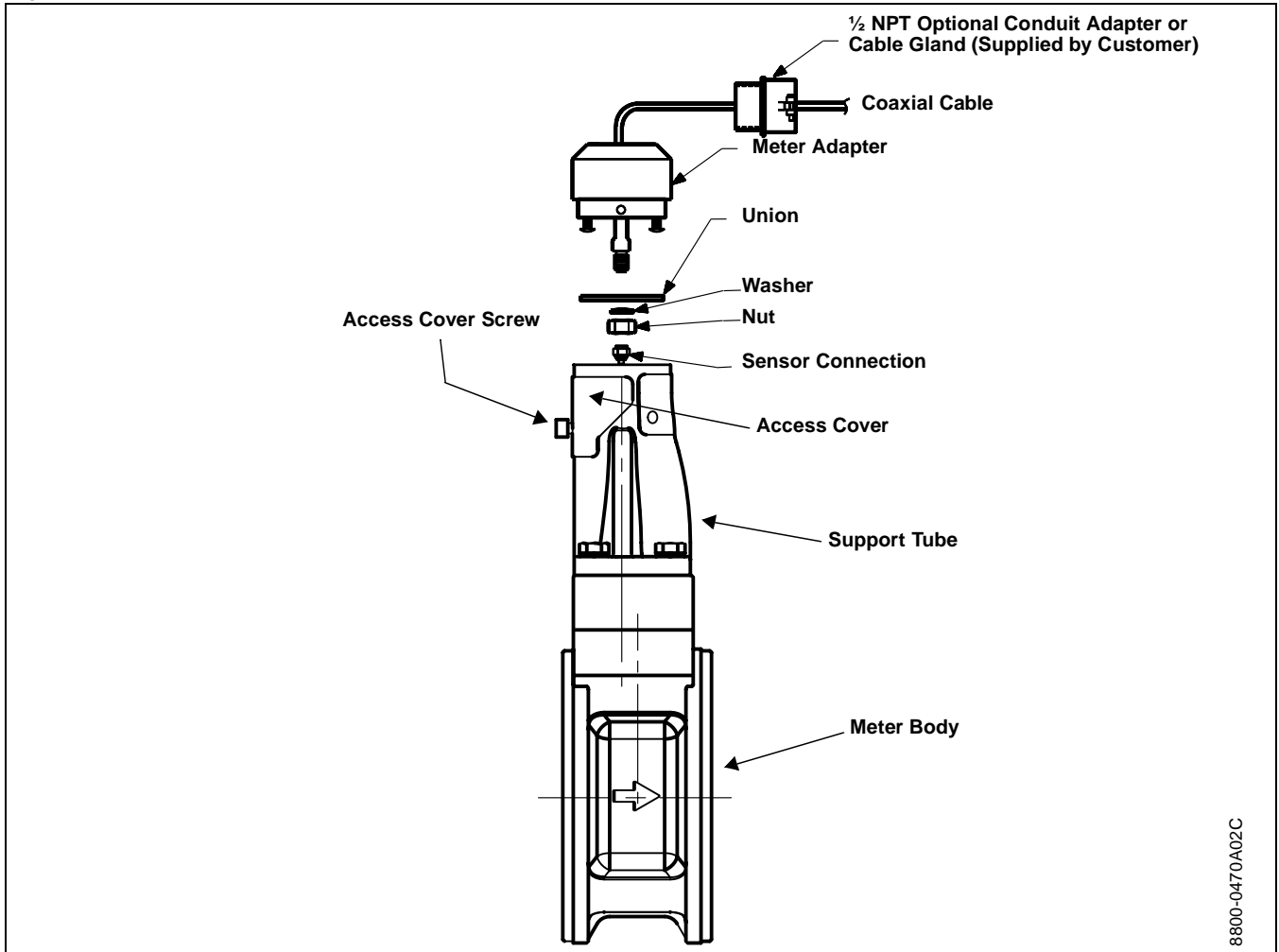

Detach the Meter Adapter

The above instructions will provide access to the meter body. Use the following steps if it is necessary to remove the coaxial cable:

1. Loosen the two screws that hold the union onto the meter adapter and pull the union away from the adapter.
2. Loosen and remove the coaxial cable nut from the other end of the union.
3. Loosen the conduit adapter or cable gland from the meter adapter.

Attach the Meter Adapter

1. If you are using a conduit adapter or cable gland, slide it over the plain end of the coaxial cable (the end without a ground wire).
2. Slide the meter adapter over the coaxial cable end.
3. Use a $\frac{5}{16}$ -inch open end wrench to securely tighten the coaxial cable nut onto one end of the union.
4. Place the union onto the two screws extending out of the meter adapter and tighten the two screws.

Connect the Coaxial Cable at the Meter

1. Pull the sensor cable out of the support tube slightly and securely tighten the sensor cable nut onto the union.

NOTE

Do not stretch the sensor cable over 1.5 inches (40 mm) beyond the top of the support tube. Damage to the sensor may occur if the sensor cable is stressed.

2. Place the meter adapter into the top of the support tube and line up the screw holes.
3. Use a hex wrench to turn the three adapter screws outward to engage the support tube.
4. Replace the access cover on the support tube.
5. Tighten the conduit adapter or cable gland into the meter adapter.

Coaxial Cable at the Electronics Housing

Disconnect the Coaxial Cable from the Electronics Housing

1. Loosen the three screws from the housing adapter.
2. Remove the adapter from the housing.
3. Loosen and remove the coaxial cable nut from the base of the electronics housing.

Remove the Coaxial Cable

1. Remove the coaxial cable ground wire from the housing adapter.

Figure 4-17. Remote Electronics Exploded View

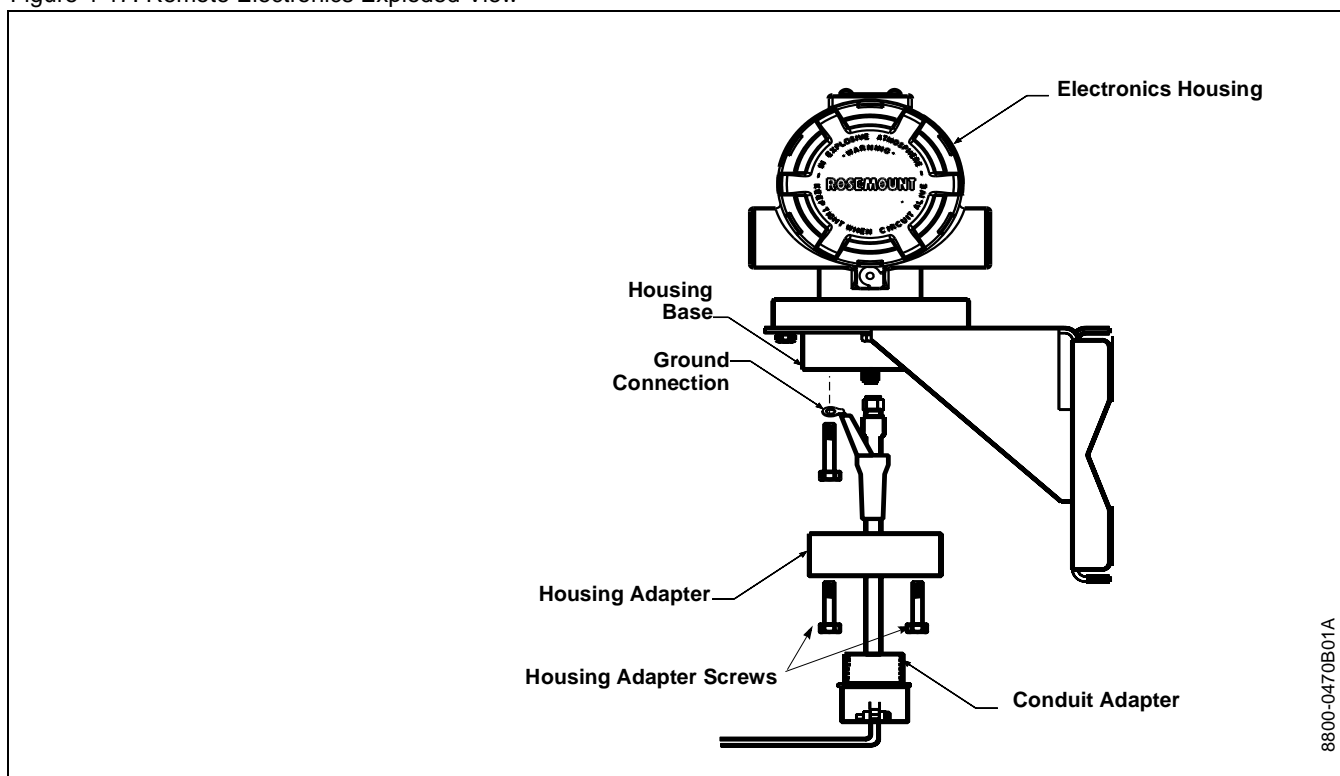

2. Loosen the conduit adapter (or cable gland) from the housing adapter.

Attach the Coaxial Cable

1. Route the coaxial cable through the conduit (if you are using conduit).
2. Place a conduit adapter over the end of the coaxial cable.
3. Remove the housing adapter from the electronics housing (if attached).
4. Slide the housing adapter over the coaxial cable.
5. Remove one of the four housing base screws.
6. Attach the coaxial cable ground wire to the housing via the housing base ground screw.

Changing the Housing Orientation

Connect the Coaxial Cable

1. Attach and securely tighten the coaxial cable nut to the connection on the electronics housing.
2. Align the housing adapter with the housing and attach with three screws.
3. Tighten the conduit adapter to the housing adapter.

The entire electronics housing may be rotated in 90 degree increments for easy viewing. Use the following steps to change the housing orientation:

1. Loosen the screw on the access cover (on the support tube) and remove the cover.
2. Loosen the three housing rotation set screws at the base of the electronics housing with a hex wrench by turning the screws clockwise (inward) until they will clear the support tube.
3. Slowly pull the electronics housing out of the support tube.
4. Unscrew the sensor cable from the housing with a $\frac{5}{16}$ -inch open end wrench.

NOTE

Do not pull the housing more than 1.5 inches (40 mm) from the top of the support tube until the sensor cable is disconnected. Damage to the sensor may occur if this sensor cable is stressed.

5. Rotate the housing to the desired orientation.
6. Hold it in this orientation while you screw the sensor cable onto the base of the housing.

NOTE

Do not rotate the housing while the sensor cable is attached to the base of the housing. This will stress the cable and may damage the sensor.

7. Place the electronics housing into the top of the support tube.
8. Use a hex wrench to turn the three housing rotation screws outward to engage the support tube.
9. Replace the access cover on the support tube.
10. Tighten the screw on the access cover.

RETURN OF MATERIAL

To expedite the return process, call the Rosemount North American Response Center at 800-654-RSMT (7768) toll-free number. This center, available 24 hours a day, will assist you with any needed information or materials.

The center will ask for product model and serial numbers, and will provide a Return Material Authorization (RMA) number. The center will also ask for the name of the process material to which the product was last exposed.

CAUTION

People who handle products exposed to a hazardous substance can avoid injury if they are informed and understand the hazard. If the product being returned was exposed to a hazardous substance as defined by OSHA, a copy of the required Material Safety Data Sheet (MSDS) for each hazardous substance identified must be included with the returned goods.

The Rosemount North American Response Center will detail the additional information and procedures necessary to return goods exposed to hazardous substances.

Reference Data

Functional Specifications	page A-1
Performance Specifications	page A-6
Physical Specifications	page A-11
Hazardous Locations Certifications	page A-13
European Atex Directive Information	page A-16
Ordering Information	page A-17

FUNCTIONAL SPECIFICATIONS

Service

Liquid, gas, and steam applications. Fluids must be homogeneous and single-phase.

Line Sizes

Wafer

1/2, 1, 1 1/2, 2, 3, 4, 6, and 8 inches
(DN 15, 25, 40, 50, 80, 100, 150, and 200)

Flanged, and Dual-Sensor Style

1/2, 1, 1 1/2, 2, 3, 4, 6, 8, 10 and 12 inches
(DN 15, 25, 40, 50, 80, 100, 150, 200, 250, and 300)

Pipe Schedules

Process piping Schedules 10, 40, and 80

NOTE

The appropriate bore diameter of the process piping must be entered using the HART Communicator or AMS. Meters will be shipped from the factory at the Schedule 40 default value unless otherwise specified.

Measurable Flow Rates

Capable of processing signals from flow applications which meet the sizing requirements below.

To determine the appropriate flowmeter size for an application, process conditions must be within the Reynolds number and velocity limitations for the desired line size provided in Table A-1, Table A-2, and Table A-3.

NOTE

Consult your local sales representative to obtain a computer sizing program that describes in greater detail how to specify the correct flowmeter size for an application.

The Reynolds number equation shown below combines the effects of density (ρ), viscosity (μ_{cp}), pipe inside diameter (D), and flow rate (V).

$$R_D = \frac{VD\rho}{m_{cp}}$$

Table A-1. Minimum Measurable Reynolds Numbers

Line Sizes (Inches / DN)	Reynolds Number Limitations
1/2 through 4 / 15 through 100	10000 minimum
6 through 12/ 150 through 300	20000 minimum

Table A-2. Minimum Measurable Velocities (Use the Larger of the Two Values)

	Feet per Second	Meters per Second
Liquids ⁽¹⁾	$\sqrt{36/\rho}$ or 0.7	$\sqrt{54/\rho}$ or 0.22
Gases	$\sqrt{36/\rho}$ or 6.5	$\sqrt{54/\rho}$ or 2.0

The ρ is the process fluid density at flowing conditions in lb/ft³ for ft/s and kg/m³ for m/s

(1) The minimum measurable velocity for the 10in. line size is 0.9 ft/s (.27m/s) and 1.1 ft/s (.34m/s) for the 12in. line size.

Table A-3. Maximum Measurable Velocities (Use the Smaller of the Two Values)

	Feet per Second	Meters per Second
Liquids	$\sqrt{90,000/\rho}$ or 25	$\sqrt{134,000/\rho}$ or 7.6
Gases ⁽¹⁾	$\sqrt{90,000/\rho}$ or 25C	$\sqrt{134,000/\rho}$ or 76

The ρ is the process fluid density at flowing conditions in lb/ft³ for ft/s and kg/m³ for m/s

(1) Accuracy limitations for gas and steam for Dual-style meters (all sizes): max velocity of 100 ft/s (30.5 m/s).

Process Temperature Limits

Standard

-40 to 450 °F (-40 to 232 °C)

Extended

-330 to 800 °F (-200 to 427 °C)

Output Signals

4–20 mA Digital HART Signal

Superimposed on 4–20 mA signal

Optional Scalable Pulse Output

0 to 10000 Hz; transistor switch closure with adjustable scaling via HART communications; capable of switching up to 30 V dc, 120 mA maximum

Analog Output Adjustment

Engineering units and lower and upper range values are user-selected. Output is automatically scaled to provide 4 mA at the selected lower range value, 20 mA at the selected upper range value. No frequency input is required to adjust the range values.

Table A-4. Water Flow Rate Limits in Schedule 40 Pipe

Line Size (Inches/DN)	Minimum and Maximum Measurable Water Flow Rates*	
	Gallons/Minute	Cubic Meters/Hour
½/ 15	1.76 to 23.7	0.40 to 5.38
1/ 25	2.96 to 67.3	0.67 to 15.3
1½/ 40	4.83 to 158	1.10 to 35.9
2/ 50	7.96 to 261	1.81 to 59.4
3/ 80	17.5 to 576	4.00 to 130
4/ 100	30.2 to 992	6.86 to 225
6/ 150	68.5 to 2251	15.6 to 511
8/ 200	119 to 3898	27.0 to 885
10/ 250	231 to 6144	52.2 to 1395
12/ 300	391 to 8813	88.8 to 2002

*Conditions: 77 °F (25 °C) and 14.7 psia (1.01 bar absolute)

Scalable Frequency Adjustment

Value of one pulse can be set to equal desired volume in selected engineering units.

Ambient Temperature Limits

Operating

–58 to 185 °F (–50 to 85 °C)

–4 to 185 °F (–20 to 85 °C) for flowmeters with local indicator

Storage

–58 to 250 °F (–50 to 121 °C)

–50 to 185 °F (–46 to 85 °C) for flowmeters with local indicator

Pressure Limits

Flange and dual-sensor style rated for ASME B16.5 (ANSI) Class 150, 300, 600, and 900, DIN PN 10, 16, 25, 40, 64, 100, and 160, and JIS 10K, 20K, and 40K

Wafer rated for ASME B16.5 (ANSI) Class 150, 300, and 600, DIN PN 10, 16, 25, 40, 64, and 100, and JIS 10K, 20K, and 40K

Power Supply

External power supply required. Flowmeter operates on 10.8 to 42 V dc terminal voltage (with 250-ohm minimum load required for HART communications, 16.8 V dc power supply is required)

Power Consumption

One watt maximum

Rosemount Model 8800C Vortex Flowmeter

Process Pressure	Flow Rate Limits	Minimum and Maximum Air Flow Rates for line sizes 1/2 inch/DN 15 through 3 inch/DN 80									
		1/2 Inch/DN 15		1 Inch/DN 25		1 1/2 Inch/DN 40		2 Inch/DN 50		3 Inch/DN 80	
		ACFM	ACMH	ACFM	ACMH	ACFM	ACMH	ACFM	ACMH	ACFM	ACMH
0 psig (0 bar G)	max	27.9	47.3	79.2	134	212	360	349	593	770	1308
	min	3.86	6.56	7.81	13.3	18.4	31.2	30.3	51.5	66.8	114
50 psig (3,45 bar G)	max	27.9	47.3	79.2	134	212	360	349	593	770	1308
	min	1.31	2.22	3.72	6.32	8.76	14.9	14.5	24.6	31.8	54.1
100 psig (6,89 bar G)	max	27.9	47.3	79.2	134	212	360	349	593	770	1308
	min	0.98	1.66	2.80	4.75	6.58	11.2	10.8	18.3	23.9	40.6
150 psig (10,3 bar G)	max	27.9	47.3	79.2	134	212	360	349	593	770	1308
	min	0.82	1.41	2.34	3.98	5.51	9.36	9.09	15.4	20.0	34.0
200 psig (13,8 bar G)	max	27.9	47.3	79.2	134	212	360	349	593	770	1308
	min	0.82	1.41	2.34	3.98	5.51	9.36	9.09	15.4	20.0	34.0
300 psig (20,7 bar G)	max	27.9	47.3	79.2	134	198	337	326	554	718	1220
	min	0.82	1.41	2.34	3.98	5.51	9.36	9.09	15.4	20.0	34.0
400 psig (27,6 bar G)	max	25.7	43.9	73.0	124	172	293	284	483	625	1062
	min	0.82	1.41	2.34	3.98	5.51	9.36	9.09	15.4	20.0	34.0
500 psig (34,5 bar G)	max	23.0	39.4	66.0	112	154	262	254	432	560	951
	min	0.82	1.41	2.34	3.98	5.51	9.36	9.09	15.4	20.0	34.0

Process Pressure	Flow Rate Limits	Minimum and Maximum Air Flow Rates for line sizes 4 inch/DN 100 through 12 inch/DN 300									
		4 Inch/DN 100		6 Inch/DN 150		8 Inch/DN 200		10 Inch/DN 250		12 Inch/DN 300	
		ACFM	ACMH	ACFM	ACMH	ACFM	ACMH	ACFM	ACMH	ACFM	ACMH
0 psig (0 bar G)	max	1326	2253	3009	5112	5211	8853	8214	13956	11781	20016
	min	115	195	261	443	452	768	712.9	1211	1022	1736
50 psig (3,45 bar G)	max	1326	2253	3009	5112	5211	8853	8214	13956	11781	20016
	min	54.8	93.2	124	211	215	365	339.5	577	486.9	827
100 psig (6,89 bar G)	max	1326	2253	3009	5112	5211	8853	8214	13956	11781	20016
	min	41.1	69.8	93.3	159	162	276	254.7	433	365.4	621
150 psig (10,3 bar G)	max	1326	2253	3009	5112	5211	8853	8214	13956	11781	20016
	min	34.5	58.6	78.2	133	135	229	213.6	363	306.3	520
200 psig (13,8 bar G)	max	1326	2253	3009	5112	5211	8853	8214	13956	11781	20016
	min	34.5	58.6	78.2	133	135	229	213.6	363	306.3	520
300 psig (20,7 bar G)	max	1237	2102	2807	4769	4862	8260	7664	13021	10992	18675
	min	34.5	58.6	78.2	133	135	229	213.6	363	306.3	520
400 psig (27,6 bar G)	max	1076	1828	2442	4149	4228	7183	6664	11322	9559	16241
	min	34.5	58.6	78.2	133	136	229	213.6	363	306.3	520
500 psig (34,5 bar G)	max	964	1638	2188	3717	3789	6437	5972	10146	8565	14552
	min	34.5	58.6	78.2	133	136	229	213.6	363	306.3	520

NOTE

The Model 8800C measures the volumetric flow under operating conditions (i.e. the actual volume at the operating pressure and temperature—acfm or acmh), as shown above. However, gas volumes are strongly dependent on pressure and temperature. Therefore, gas quantities are typically stated in standard or normal conditions (e.g. Scfm or Ncmh). (Standard conditions are typically 59 °F and 14.7 psia. Normal conditions are typically 0 °C and 1 bar abs).

The flow rate limits in standard conditions are found using the equations below:

$$\text{Standard Flow Rate} = \text{Actual Flow Rate} \times \text{Density Ratio}$$

$$\text{Density Ratio} = \frac{\text{Density at Actual (Operating) Conditions}}{\text{Density at Standard Conditions}}$$

Process Pressure	Flow Rate Limits	Minimum and Maximum Saturated Steam ⁽¹⁾ Flow Rates for line sizes 1/2 inch/DN 15 through 3 inch/DN 80									
		1/2 Inch/DN 15		1 Inch/DN 25		1 1/2 Inch/DN 40		2 Inch/DN 50		3 Inch/DN 80	
		lb/hr	kg/hr	lb/hr	kg/hr	lb/hr	kg/hr	lb/hr	kg/hr	lb/hr	kg/hr
15 psig (1,03 bar G)	max	120	54.6	342	155	917	416	1511	685	3330	1510
	min	12.8	5.81	34.8	15.8	82.0	37.2	135	61.2	298	135
25 psig (1,72 bar G)	max	158	71.7	449	203	1204	546	1983	899	4370	1982
	min	14.0	6.35	39.9	18.1	93.9	42.6	155	70.2	341	155
50 psig (3,45 bar G)	max	250	113	711	322	1904	864	3138	1423	6914	3136
	min	17.6	8.00	50.1	22.7	118	53.4	195	88.3	429	195
100 psig (6,89 bar G)	max	429	194	1221	554	3270	1483	5389	2444	11874	5386
	min	23.1	10.5	65.7	29.8	155	70.1	255	116	562	255
150 psig (10,3 bar G)	max	606	275	1724	782	4616	2094	7609	3451	16763	7603
	min	27.4	12.5	78.1	35.4	184	83.2	303	137	668	303
200 psig (13,8 bar G)	max	782	354	2225	1009	5956	2702	9818	4453	21630	9811
	min	31.2	14.1	88.7	40.2	209	94.5	344	156	759	344
300 psig (20,7 bar G)	max	1135	515	3229	1464	8644	3921	14248	6463	31389	14237
	min	37.6	17.0	107	48.5	252	114	415	189	914	415
400 psig (27,6 bar G)	max	1492	676	4244	1925	11362	5154	18727	8494	41258	18714
	min	44.1	20.0	125	56.7	295	134	487	221	1073	487
500 psig (34,5 bar G)	max	1855	841	5277	2393	14126	6407	23284	10561	51297	23267
	min	54.8	24.9	156	70.7	367	167	605	274	1334	605

(1) Assumes steam quality is 100%

Process Pressure	Flow Rate Limits	Minimum and Maximum Saturated Steam ⁽¹⁾ Flow Rates for line sizes 4 inch/DN 100 through 12 inch/DN 300									
		4 Inch/DN 100		6 Inch/DN 150		8 Inch/DN 200		10 Inch/DN 250		12 Inch/DN 300	
		lb/hr	kg/hr	lb/hr	kg/hr	lb/hr	kg/hr	lb/hr	kg/hr	lb/hr	kg/hr
15 psig (1,03 bar G)	max	5734	2601	13013	5903	22534	10221	35519	16111	50994	23130
	min	513	233	1163	528	2015	914	3175	1440	4554	2066
25 psig (1,72 bar G)	max	7526	3414	17080	7747	29575	13415	46618	21146	66862	30328
	min	587	267	1333	605	2308	1047	4570	2073	5218	2367
50 psig (3,45 bar G)	max	11905	5400	27019	12255	46787	21222	73748	33452	105774	47978
	min	739	335	1676	760	2903	1317	4575	2075	6562	2976
100 psig (6,89 bar G)	max	20448	9275	46405	21049	80356	36449	126660	57452	181663	82401
	min	968	439	2197	996	3804	1725	5996	2720	8600	3901
150 psig (10,3 bar G)	max	28866	13093	65611	29761	113440	51455	178808	81106	256457	116327
	min	1150	522	2610	1184	4520	2050	7125	3232	10218	4635
200 psig (13,8 bar G)	max	37247	16895	84530	38342	146375	66395	230722	104654	330915	150101
	min	1307	593	2965	1345	5134	2329	8092	3670	11607	5265
300 psig (20,7 bar G)	max	54052	24517	122666	55640	212411	96348	334810	151867	480203	217816
	min	1574	714	3572	1620	6185	2805	9749	4422	13983	6343
400 psig (27,6 bar G)	max	71047	32226	161236	73135	279200	126643	440085	199619	631195	286305
	min	1847	838	4192	1901	7259	3293	11442	5190	16411	7444
500 psig (34,5 bar G)	max	88334	40068	200468	90931	347134	157457	547165	248190	784775	355968
	min	2297	1042	5212	2364	9025	4094	14226	6453	20404	9255

(1) Assumes steam quality is 100%

Load Limitations

Maximum loop resistance is determined by the voltage level of the external power supply, as described by:

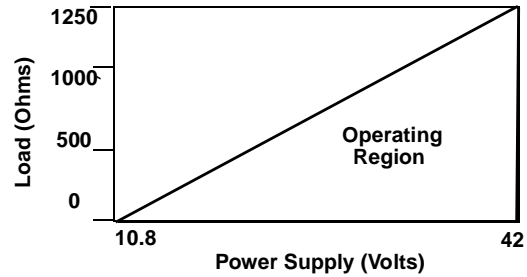

$$R_{\max} = 41.7(V_{\text{ps}} - 10.8)$$

V_{ps} = Power Supply Voltage (Volts)
 R_{\max} = Maximum Loop Resistance (Ohms)

NOTE

HART Communication requires a minimum loop resistance of 250 ohms.

Optional LCD Indicator

Displays flow variable, percent of range, current output, and/or totalized flow

Enclosure Rating

NEMA Type 4X; CSA Type 4X; IP66

PERFORMANCE SPECIFICATIONS

Accuracy

Includes linearity, hysteresis, and repeatability

Liquids—for Reynolds Numbers over 20000

Digital and Pulse Output

±0.65% of rate

Analog Output

Same as pulse output plus an additional 0.025% of span

**Gas and Steam—
for Reynolds Numbers over 15,000**

Digital and Pulse Output
±1.35% of rate

Analog Output
Same as pulse output plus an additional 0.025% of span

Accuracy limitations for gas and steam:

- for 1/2- and 1-in. (DN 15 and DN 25):
max velocity of 220 ft/s (67.06 m/s)
- for Dual-style meters (all sizes):
max velocity of 100 ft/s (30.5 m/s)

NOTE

For 1/2-in. through 4-in. (15 mm through 100 mm) line sizes, as the Reynolds number decreases below the stated limit to 10000, the positive limit of the accuracy error band will increase to 2.1% for the pulse output. Example: +2.1% to -0.65% for liquids.

Repeatability

± 0.1% of actual flow rate

Stability

±0.1% of rate over one year

Process Temperature Effect

Automatic K-factor correction with user-entered process temperature
Table A-5 indicates the percent change in K-factor per 100 °F (50 °C) in process temperature from reference temperature of 77 °F (25 °C) for direct pulse, or user-entered process temperature.

Table A-5. Process Temperature Effect

Material	Percent Change in K-Factor per 100 °F (50 °C)
316L @ < 77 °F (25 °C)	+ 0.23 (+ 0,20)
316L @ > 77 °F (25 °C)	- 0.27 (- 0,24)
Hastelloy® C @ < 77 °F (25 °C)	+ 0.22 (+ 0,20)
Hastelloy® C @ > 77 °F (25 °C)	- 0.22 (- 0,20)

Ambient Temperature Effect

Digital and Pulse Outputs

No effect

Analog Output

±0.1% of span from -40 to 185 °F (-40 to 85 °C)

Vibration Effect

An output with no process flow may be detected if sufficiently high vibration is present.

The meter design will minimize this effect, and the factory settings for signal processing are selected to eliminate these errors for most applications.

If an output error at zero flow is still detected, it can be eliminated by adjusting the low flow cutoff, trigger level, or low-pass filter.

As the process begins to flow through the meter, most vibration effects are quickly overcome by the flow signal. At or near the minimum liquid flow rate in a normal pipe mounted installation, the maximum vibration should be 0.087-inch (2,21 mm) double amplitude displacement or 1 g acceleration, whichever is smaller. At or near the minimum gas flow rate in a normal pipe mounted installation, the maximum vibration should be 0.043-inch (1,09 mm) double amplitude displacement or $\frac{1}{2}$ g acceleration, whichever is smaller.

Mounting Position Effect

Meter will meet accuracy specifications when mounted in horizontal, vertical, or inclined pipelines.

EMI/RFI Effect

Output error less than $\pm 0.025\%$ of span with twisted pair from 80-1000 MHz for radiated field strength of 10 V/m and from 0.15-80 MHz for conducted RF of 3V (tested per EN61326).

Magnetic-Field Interference

Output error less than $\pm 0.025\%$ of span at 30 A/m (rms); meets IEC 770-1984, Section 6.2.9.

Series Mode Noise Rejection

Output error less than $\pm 0.025\%$ of span at 1 V rms, 60 Hz; meets IEC 770-1984, Section 6.2.4.2.

Common Mode Noise Rejection

Output error less than $\pm 0.025\%$ of span at 30 V rms, 60 Hz; meets IEC 770-1984, Section 6.2.4.1.

Power Supply Effect

Less than 0.005% of span per volt

Pressure Loss

The approximate pressure loss from the flowmeter can be determined using the following equations:

English

$$(\text{Liquids})_{\Delta P} = \frac{(3.40 \times 10^{-5}) \times \rho_f \times (Q_{gpm})^2}{D^4}$$

$$(\text{Gases})_{\Delta P} = \frac{(1.90 \times 10^{-3}) \times \rho_f \times (Q_{acfm})^2}{D^4}$$

Metric

$$(\text{Liquids})_{\Delta P} = \frac{(0.425) \times \rho_f \times (Q_{lpm})^2}{D^4}$$

$$(\text{Gases})_{\Delta P} = \frac{(118) \times \rho_f \times (Q_{acmh})^2}{D^4}$$

where:

- ΔP = Pressure loss (psi or kPa)
- ρ_f = Density at operating conditions (lb/ft³ or kg/m³)
- D = Flowmeter bore diameter (in. or mm)
- Q_{gpm} or lpm = Actual volumetric flow rate (gal/min or l/min)
- Q_{acfm} or $acmh$ = Actual volumetric flow rate (ft³/min or m³/hour)

NOTE

Pressure loss is 1.8 ΔP for the dual sensor meter.

Minimum Back Pressure (Liquids)

Flow metering conditions that would allow cavitation, the release of vapor from a liquid, should be avoided. This flow condition can be avoided by remaining within the proper flow range of the meter and by following appropriate system design.

For some liquid applications, incorporation of a back pressure valve should be considered. To prevent cavitation, the minimum back pressure should be:

$$P = 2.9\Delta P + 1.3 p_v$$

P = Line pressure five pipe diameters downstream of the meter (psia or kPa abs)

ΔP = Pressure loss across the meter (psi or kPa)

p_v = Liquid vapor pressure at operating conditions (psia or kPa abs)

NOTE

Pressure loss is 1.8 ΔP for the dual sensor meter.

Failure Mode Alarm

If self-diagnostics detect a gross flowmeter failure, the analog signal will be driven either below 3.75 mA or above 21.75 mA to alert the user. Also, high or low alarm signal is user-selectable through the fail mode alarm jumper on the electronics.

NAMUR-compliant alarm limits are available through the C4 or CN Option. NAMUR-compliant limits are 3.6 mA (low) or 22.5 mA (high).

Saturation Output Values

When the operating flow is outside the range points, the analog output continues to track the operating flow until reaching the saturation value listed below; the output does not exceed the listed saturation value regardless of the operating flow.

The 4–20 mA Saturation Values are 3.9 mA (low) or 20.8 mA (high). The NAMUR-Compliant Saturation Values (Option C4 or CN) are 3.8 mA (low) or 20.5 mA (high).

Damping

Adjustable between 0.2 and 255 seconds

Response Time

Three vortex shedding cycles or 0.2 seconds, whichever is greater, maximum required to reach 63.2% of actual input with the minimum damping (0.2 seconds).

Turn-on Time

Less than four (4) seconds plus the response time to rated accuracy from power up.

Transient Protection

The optional transient terminal block prevents damage to the flowmeter from transients induced by lightning, welding, heavy electrical equipment, or switch gears. The transient protection electronics are located in the terminal block.

The transient terminal block meets the following specifications:

ASME B16.5 (ANSI)/IEEE C62.41 - 1980
(IEEE 587) Categories A, B

3 kA crest ($8 \times 20 \mu\text{s}$)

6 kV crest ($1.2 \times 50 \mu\text{s}$)

6 kV/0.5 kA (0.5 μs , 100 kHz, ring wave)

Security Lockout

When the security lockout jumper is enabled, the electronics will not allow you to modify functions that affect flowmeter output.

Output Testing

Current Source

Flowmeter may be commanded to set the current to a specified value between 4 and 20 mA.

**PHYSICAL
SPECIFICATIONS****Frequency Source**

Flowmeter may be commanded to set the frequency to a specified value between 0 and 10000 Hz.

Low Flow Cutoff

Adjustable over entire flow range. Below selected value, output is driven to 4 mA and zero pulse output frequency (in the scaled pulse mode only).

Humidity Limits

Operates in 0–95% relative humidity under noncondensing conditions (tested to IEC 770, Section 6.2.11).

Overrange Capability

Analog signal output continues to 105 percent of span, then remains constant with increasing flow. The digital and pulse outputs will continue to indicate flow up to the upper sensor limit of the flowmeter and a maximum frequency of 10400 Hz.

Flow Calibration

Meter bodies are flow-calibrated and assigned a unique calibration factor (K-factor) at the factory. The calibration factor is entered into the electronics, enabling interchangeability of electronics and/or meter bodies without calculations or compromise in accuracy.

NACE Compliance

Meets the requirements of NACE (National Association of Corrosion Engineers) Standard MR-01-75 (96)

Electrical Connections

1/2 –14 NPT, PG 13.5, or M20 × 1.5 conduit threads; screw terminals provided for 4–20 mA and pulse output connections; communicator connections permanently fixed to terminal block.

Non-Wetted Materials**Housing**

Low-copper aluminum
(NEMA 4X, CSA Type 4X, IP66)

Paint

Polyurethane

Cover O-rings

Buna-N

Flanges

316/316L lap joint

Process-Wetted Materials**Meter Body**

316L wrought stainless and CF-3M cast stainless or C-22[®] and C-276 wrought Hastelloy[®] or CX2MW and CW12MW cast Hastelloy.

Flanges

316/316L stainless steel

Collars

Hastelloy C-22[®]

Surface Finish of Flanges and Collars

Standard: 125 to 250 μ inches
(3.1 to 6.3 μ meters) Ra roughness

Smooth: 63 to 125 μ inches
(1.6 to 3.1 μ meters) Ra roughness

Process Connections

Mounts between the following flange configurations:

ASME B16.5 (ANSI): Class 150, 300, 600, 900

DIN: PN 10, 16, 25, 40, 64, 100, 160

JIS: 10K, 20K, and 40K

Mounting

Integral (Standard)

Electronics are mounted on meter body

Remote (Optional)

Electronics may be mounted remote from the meter body. Interconnecting coaxial cable available in nonadjustable 10, 20, and 30 ft (3,0, 6,1, and 9,1 m) lengths. Consult factory for non-standard lengths up to 75 ft (22,9 m). Remote mounting hardware includes a polyurethane painted, carbon steel pipe mount bracket with one carbon steel u-bolt.

Pipe Length Requirements

The vortex meter may be installed with a minimum of *ten straight pipe diameters (D) upstream* and *five straight pipe diameters (D) downstream*.

Rated accuracy is based on the number of pipe diameters from an upstream disturbance. An additional 0.5% shift in K-factor may be introduced between 10 D and 35 D, depending on disturbance. For more information on installation effects, see Technical Data Sheet 00816-0100-3250.

**HAZARDOUS LOCATIONS
CERTIFICATIONS****Factory Mutual (FM) Approvals**

- E5** Explosion-proof for
Class I, Division 1, Groups B, C, and D;
Dust-Ignition proof for
Class II/III, Division 1, Groups E, F, and G;
factory sealed
- I5** Intrinsically safe for use in
Class I, Division 1, Groups A, B, C, and D;
Class II/III, Division 1, Groups E, F, and G;
Temp. code T4 only when connected in accordance with
Rosemount drawings 08800-0106 and 00268-0031;
Non-incendive for
Class I, Division 2, Groups A, B, C, and D;
factory sealed.
Entity Parameters:
 $U_i = 30 \text{ V}$
 $I_i = 300 \text{ mA}$
 $P_i = 1.3 \text{ W}$
 $C_i = 0.0 \mu\text{F}$
 $L_i = 40 \mu\text{H}$
- K5** E5 and I5 combination
 $U_i = 30 \text{ V}$
 $I_i = 300 \text{ mA}$
 $P_i = 1.3 \text{ W}$
 $C_i = 0.0 \mu\text{F}$
 $L_i = 40 \mu\text{H}$

Canadian Standards Association (CSA) Approvals

- E6** Explosion-proof for Class I, Division 1, Groups B, C, and D;
Dust-Ignition proof for Class II, Division 1, Groups E, F, and G;
Class III, Division 1
Hazardous locations;
Class I, Division 2, Groups A, B, C, and D;
factory sealed
- I6** Intrinsically safe for Class I, Division 1, Groups A, B, C, and D;
Intrinsic safety approval only when connected in accordance with Rosemount drawing 08800-0111;
temperature code T3C (see Table A-6)
- C6** E6 and I6 combination (see Table A-6)

Table A-6. CSA Entity Approvals

Barrier Manufacturer/Model	CSA Approved for Class I, Division 1, Groups			
	A	B	C	D
Any CSA approved zener barrier ≤ 30 V, ≥ 330 Ω or ≤ 28 V, ≥ 300 Ω or ≤ 25 V, ≥ 200 Ω or ≤ 22 V, ≥ 180 Ω	•	•	•	•
Foxboro Converters 2AI-12V-CGB, 2AI-13V-CGB 2AS-I3I-CGB, 3A2-I2D-CGB 3A2-I3D-CGB, 3AD-I3I-CGB 3A4-I2D-CGB, 2AS-I2I-CGB 3F4-I2DA	NA	•	•	•
Any CSA approved zener barrier ≤ 30 V, ≥ 150 Ω	NA	NA	•	•

CENELEC Intrinsic Safety and Dust Certification

I1 ATEX Marking Ex II 1 GD T 70°C
 Certification No. BAS99ATEX1222
 EEx ia IIC T5 ($T_{amb} = -50$ to 40 °C)
 EEx ia IIC T4 ($T_{amb} = -50$ to 70 °C)
 Entity Parameters:
 $U_i = 30$ V
 $I_i^{(1)} = 300$ mA
 $P_i^{(1)} = 1$ W
 $C_i = 0.0$ μ F
 $L_i = 40$ μ H

(1) Total for transmitter

CENELEC Type N Certification

N1 ATEX Marking Ex II 3 GD T70°C
 Certification No. BAS99ATEX3221
 EEx nL IIC T5 ($T_{amb} = -40$ °C to 70 °C)
 42 Vdc max

CENELEC Flameproof Certification

ED ATEX Marking Remote Mount:
 Ex II 2 (1) G T70°C
 ATEX Marking Integral Mount
 Ex II 1/2 G T70°C
 KEMA Certification No. 99ATEX3852X
 EEx d [ia] IIC T6
 ($T_{amb} = -50$ °C to 70 °C)

Special Conditions

When installed particular precautions must be taken to ensure taking account with the effect of the fluid temperature, that the ambient temperature of the electrical parts of the apparatus is comprised between -50 °C and 70 °C.

Standards Association of Australia (SAA)⁽¹⁾ Certifications

E7 Flameproof:
 Ex d [ia] IIC T6 ($T_{amb} = 40$ °C)
 Ex d [ia] IIC T4 ($T_{amb} = 70$ °C)
 Class I, Zone 1; IP66

I7 When connected in accordance with Rosemount Drawing 08800-0121
 Intrinsic Safety:
 Ex ia IIC T6 ($T_{amb} = 40$ °C)
 Ex ia IIC T4 ($T_{amb} = 70$ °C)
 Class I, Zone 0
 Entity Parameters:
 $U_i = 30$ V
 $I_i^{(2)} = 300$ mA
 $P_i^{(2)} = 1$ W
 $C_i = 0.016$ mF
 $L_i = 40$ mH

N7 Type N: Ex n IIC T6 ($T_{amb} = 40$ °C)
 Ex n IIC T4 ($T_{amb} = 85$ °C)
 Class I, Zone 2

(1) Pending final approval

(2) Total for transmitter

**EUROPEAN ATEX
DIRECTIVE INFORMATION**

Rosemount Model 8800C and 8800A Vortex Flowmeter Transmitters that have the following labels attached have been certified to comply with Directive 94/9/EC of the European Parliament and the Council as published in the Official Journal of the European Communities No. L 100/1 on 19-April-1994.

The following information is provided as part of the labeling of the transmitter:

- Name and address of the manufacturer (Rosemount U.S.A)
- **CE** 0600
- Complete model number
- The serial number of the device
- Year of construction

Marking for explosion protection:

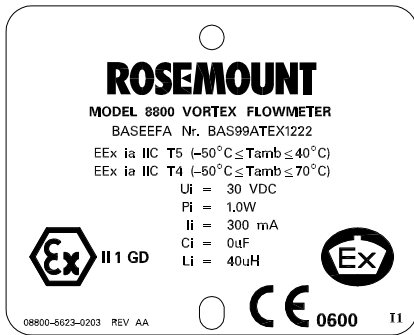

BASEEFA ATEX
Certification Number:
BAS00ATEX1222

Ex II 1 GD

EEx ia IIC
T5 (T_{amb} = -50 to 40 °C)
T4 (T_{amb} = -50 to 70 °C)

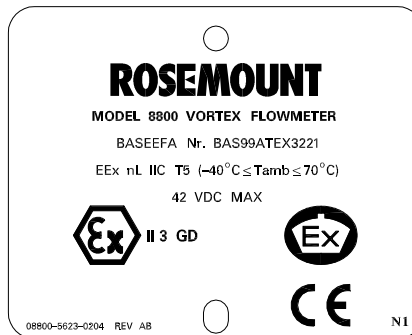

or BASEEFA ATEX
Certification Number:
BAS00ATEX3221

Ex II 3 GD

EEx nL IIC
T5 (T_{amb} = -40 to 70 °C)

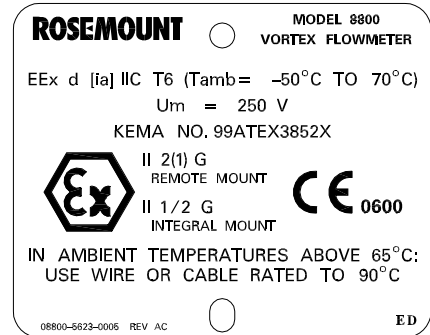

or KEMA ATEX
Certification Number:
99ATEX3852X

Ex II 2 (1) G Remote Mount

Ex II 1/2 G Integral Mount

EEx d [ia] IIC
T6 (T_{amb} = -50 to 70 °C)

ORDERING INFORMATION

Model	Product Description
8800C	Vortex Flowmeter
8800A	Vortex Flowmeter, <i>Hastelloy</i> ® wafer meters only
Code	Meter Style
W	Wafer style
F	Flanged style
D	Dual-sensor style (Flanged style only)
Code	Line Size
005	1/2 Inch (15 mm)
010	1 Inch (25 mm)
015	1 1/2 Inches (40 mm)
020	2 Inches (50 mm)
030	3 Inches (80 mm)
040	4 Inches (100 mm)
060	6 Inches (150 mm)
080	8 Inches (200 mm)
100	10 Inches (250mm)
120	12 Inches (300mm)
Code	Wetted Materials
S	316L wrought stainless and CF-3M cast stainless
H ⁽¹⁾	C-22® and C-276 wrought <i>Hastelloy</i> ®; CX2MW and CW12MW cast <i>Hastelloy</i> ®
Code	Flange or Alignment Ring Size
A1	ASME B16.5 (ANSI) RF Class 150
A3	ASME B16.5 (ANSI) RF Class 300
A6	ASME B16.5 (ANSI) RF Class 600
A7 ⁽²⁾	ASME B16.5 (ANSI) RF Class 900
B1	ASME B16.5 (ANSI) RTJ Class 150 for flange-style only
B3	ASME B16.5 (ANSI) RTJ Class 300 for flange-style only
B6	ASME B16.5 (ANSI) RTJ Class 600 for flange-style only
B7 ⁽²⁾	ASME B16.5 (ANSI) RTJ Class 900 for flange-style only
C1	ASME B16.5 (ANSI) RF Class 150, smooth finish
C3	ASME B16.5 (ANSI) RF Class 300, smooth finish
C6	ASME B16.5 (ANSI) RF Class 600, smooth finish
C7 ⁽²⁾	ASME B16.5 (ANSI) RF Class 900, smooth finish
D0	DIN PN 10 2526-Type D
D1	DIN PN 16 (PN 10/16 for wafer-style)2526-Type D
D2	DIN PN 25 2526-Type D
D3	DIN PN 40 (PN 25/40 for wafer-style) 2526-Type D
D4	DIN PN 64 2526-Type D
D6 ⁽³⁾	DIN PN 100 2526-Type D
D7 ⁽²⁾	DIN PN 160 2526-Type D
G0	DIN PN 10 2512-Type N for flange-style only
G1	DIN PN 16 2512-Type N for flange-style only
G2	DIN PN 25 2512-Type N for flange-style only
G3	DIN PN 40 2512-Type N for flange-style only
G4	DIN PN 64 2512-Type N for flange-style only
G6	DIN PN 100 2512-Type N for flange-style only
G7 ⁽²⁾	DIN PN 160 2512-Type N for flange-style only

Continued on Next Page

Rosemount Model 8800C Vortex Flowmeter

Code	Flange or Alignment Ring Size
H0	DIN PN 10 2526-Type E
H1	DIN PN 16 (PN 10/16 for wafer-style) 2526-Type E
H2	DIN PN 25 2526-Type E
H3	DIN PN 40 (PN 25/40 for wafer-style) 2526-Type E
H4	DIN PN 64 2526-Type E
H6 ⁽³⁾	DIN PN 100 2526-Type E
H7 ⁽²⁾	DIN PN 160 2526-Type E
J1	JIS 10K
J2	JIS 20K
J4	JIS 40K
Code	Sensor Process Temperature Range
N	Standard: -40 to 450°F (-40 to 232°C)
E	Extended: -330 to 800°F (-200 to 427°C)
Code	Conduit Entry
1	1/2 -14 NPT
2	M20 × 1.5
3	PG 13.5
Code	Outputs
D	4-20 mA digital electronics (Hart [®] protocol)
P	4-20 mA digital electronics (Hart [®] protocol) with scaled pulse
Code	Calibration
1	Flow calibration
Code	Options
Hazardous Locations Certifications	
E5	Factory Mutual (FM) explosion-proof approval
I5	Factory Mutual (FM) intrinsic safety approval
K5	Factory Mutual (FM) E5 and I5 combination approval
I1	CENELEC intrinsic safety and dust certification
N1	CENELEC Type N certification
ED	CENELEC flameproof certification
E6	Canadian Standards Association (CSA) explosion-proof approval
I6	Canadian Standards Association (CSA) intrinsic safety approval
C6	Canadian Standards Association (CSA) E6 and I6 combination approval
E7	Standards Association of Australia (SAA) flameproof certification (pending final approval)
I7	Standards Association of Australia (SAA) intrinsic safety certification (pending final approval)
N7	Standards Association of Australia (SAA) Type N certification (pending final approval)
Other Options	
M5	LCD indicator
P2	Cleaning for special services
C4	Analog output levels compliant with NAMUR recommendation NE43, 18-January-1994 and high alarm level ⁽⁴⁾
CN	Analog output levels compliant with NAMUR recommendation NE43, 18-January-1994 and low alarm level ⁽⁴⁾
R10	Remote electronics with 10 ft (3,0 m) cable
R20	Remote electronics with 20 ft (6,1 m) cable
R30	Remote electronics with 30 ft (9,1 m) cable
RXX	Remote electronics with customer-specified cable length (up to 75 ft (23 m) maximum) ⁽⁵⁾
T1	Transient protection terminal block
V5	External ground screw assembly ⁽⁶⁾

Options Continue	
Certification Options	
Q4	Calibration data sheet per ISO 10474 3.1.B
Q8	Material traceability certification per ISO 10474 3.1.B
Q14	German TRB 801 Nr.45 certification per ISO 10474 3.1.B ⁽⁷⁾
Q69	Inspection certificate weld examination (wafer) per ISO 10474 3.1.B ⁽⁸⁾
Q70	Inspection certificate weld examination (flanged) per ISO 10474 3.1.B
Q71	Inspection certification weld examination (flanged) per ISO 10474 3.1.B (includes x-rays)
Typical Model Number: 8800C F 020 S A1 N 1 D 1 M5	

- (1) 1/2-in. (15 mm) through 4-in. (100 mm) flanged-style meters are with A1, A3, A6, C1, C3, D1, D3, D6, H1, H3, J1, J2, and J4 flange codes only. 6-in. (150mm) and 8-in. (200 mm) are only available in A1, A3, A6, D1, D3, D6, J1, J2, and J4 flange codes.
- 1/2-in. (15mm)through 4-in. (100mm) with flange codes A1, A3, A6, C1, and C3; 2-in. (50 mm) through 4-in. (100mm) with flange codes D1, D3, H1, and H3 codes use lap joint flanges; all others use weld-neck flanges.
- (2) Only available for stainless steel flanged and dual-sensor style meters in line sizes 1-in. (25 mm) through 4-in. (100 mm).
- (3) D6 and H6 are not available for stainless steel 3-in. (80 mm) wafer meter style).
- (4) NAMUR compliant operation and the alarm latch options are pre-set at the factory and cannot be changed to standard operation in the field.
- (5) XX is a customer specified length in feet.
- (6) V5 only available with no approval or E5, I5, K5, E6, I6, and C6; it is standard with the other approvals.
- (7) Q14 is not available with flange codes A7, B7, C7, D7, G7,H7 and 10in.-12in. meter.
- (8) Q69 available for all Hastelloy[®] wafers and stainless steel wafers in line sizes 1/2-in. (15 mm), 6-in. (150 mm), and 8-in. (200 mm).

Table A-7. Spare Parts List

Part Description	Spare Category ⁽¹⁾	Part Number
Electronics Housing with Electronics and Terminal Block (includes covers)		
Analog/ HART Electronics		08800-5107-3001
Analog/ HART and Pulse Electronics		08800-5107-3002
Analog/ HART Electronics with K5 Approval		08800-5107-3151
Analog/ HART and Pulse Electronics with K5 Approval		08800-5107-3152
Analog/ HART Electronics with C6 Approval		08800-5107-3101
Analog/ HART and Pulse Electronics with C6 Approval		08800-5107-3102
Analog/ HART Electronics with I1 Approval		08800-5107-3131
Analog/ HART and Pulse Electronics with I1 Approval		08800-5107-3132
Analog/ HART Electronics with N1 Approval		08800-5107-3241
Analog/ HART and Pulse Electronics with N1 Approval		08800-5107-3242
Analog/ HART Electronics with ED Approval		08800-5107-3051
Analog/ HART and Pulse Electronics with ED Approval		08800-5107-3052
FOUNDATION [™] fieldbus Electronics		08800-5107-3003
FOUNDATION [™] fieldbus Electronics with K5 Approval		08800-5107-3153
FOUNDATION [™] fieldbus Electronics with C6 Approval		08800-5107-3103
FOUNDATION [™] fieldbus Electronics with ED Approval		08800-5107-3053
FOUNDATION [™] fieldbus Electronics with I1 Approval		08800-5107-3133
FOUNDATION [™] fieldbus Electronics with N1 Approval		08800-5107-3243

Rosemount Model 8800C Vortex Flowmeter

Table A-7. Spare Parts List

Part Description	Spare Category ⁽¹⁾	Part Number
Housing		
Electronics Housing Only (For Use with Analog/HART Electronics)		08800-5110-1001
Electronics Housing Only (For Use with Analog/HART and Pulse Electronics)		08800-5110-1002
Housing Cover (Includes O-Ring and Wiring Label)		08800-5104-1001
Electronics Housing Only (For Use with FOUNDATION™ fieldbus Electronics)		08800-5110-1003
Housing Cover (Includes O-Ring and FOUNDATION™ fieldbus Wiring Label)		08800-5104-2001
O-Ring for Housing Cover (Package of 12)		08800-5105-0001
Electronics		
Electronics (2-Board) Set Analog/HART Output	A	08800-5120-3001
Electronics (2-Board) Set Analog/HART and Pulse Output	A	08800-5120-3002
Electronics (2-Board) Set Analog/HART NAMUR Compliant		08800-5120-3011
Electronics (2-Board) Set Analog/HART and Pulse NAMUR Compliant		08800-5120-3012
FOUNDATION™ fieldbus Electronics (2-Board) Set/Assembly Hardware	A	08800-5120-3003
Jumpers (Set of 25)	A	08800-5108-0025
Terminal Block		
Analog/HART Output Only	A	08800-5106-1001
Analog/HART and Pulse Outputs	A	08800-5106-1003
Analog/HART Output with Transient Protection	A	08800-5106-1002
Analog/HART and Pulse Outputs with Transient Protection	A	08800-5106-1004
FOUNDATION™ fieldbus Output	A	08800-5106-2001
LCD Indicator		
LCD Indicator Kit (Includes LCD Indicator, Mounting Hardware, and Cover Kit)		08800-5640-0002
LCD Indicator (Includes LCD Indicator and Mounting Hardware)	A	08800-5640-0003
FOUNDATION™ fieldbus LCD Indicator Kit (Includes LCD Indicator, Mounting Hardware, and Cover Kit)		08800-5640-0005
FOUNDATION™ fieldbus LCD Indicator (Includes LCD Indicator and Mounting Hardware)	A	08800-5640-0006
Indicator Cover Kit		08800-5541-0001
Sensor		
Standard Temperature Range	A	08800-0250-0002
Extended Temperature Range	A	08800-0250-0001
Sensor Nut		
Wafer - SST: 1/2-2, 6-8 in. (15-50, 150-200mm), Hastelloy: 1/2-8 in. (15-200 mm)		08800-5100-0001
Flanged - SST and Hastelloy: 1/2-1 1/2 in. (15-40 mm)		08800-5100-0001
Wafer - SST: 3-4 in. (50-100 mm)		08800-5100-0002
Access Cover		
Wafer - SST: 6-8 in. (150-200mm), Hastelloy: 2-8 in. (50-200 mm)	B	08800-5007-0001
Wafer - SST: 1/2-4 in. (15-100 mm), Hastelloy: 1/2-1 1/2 in. (15-40 mm)	B	08800-5020-0001
Flanged - SST and Hastelloy: 1/2-8 in. (15-200 mm)	B	08800-5020-0001
Meter Support Tube Kit (Includes Bolts)		
Wafer - SST: 1/2-4 in. (15-100 mm), Hastelloy: 1/2-1 1/2 in. (15-40 mm)	B	08800-5101-0001
Flanged - SST and Hastelloy: 1/2-1 1/2 in. (15-40 mm)	B	08800-5101-0001
Flanged - SST and Hastelloy: 2-8 in. (50-200 mm)	B	08800-5101-0002

Table A-7. Spare Parts List

Part Description	Spare Category ⁽¹⁾	Part Number
Remote Mounting Kits		
(Includes All Parts Needed to Retrofit an Integral Transmitter and Meter Body to Mount the Electronics Remotely)		
Remote Mounting Kit with 10 ft. (3,0m) Cable		08800-5051-2010
Remote Mounting Kit with 20 ft. (6,1m) Cable		08800-5051-2020
Remote Mounting Kit with 30 ft. (9,1m) Cable		08800-5051-2030
Remote Mounting Kit with Customer-Specified Cable Length. Up to 75 ft. (23 m). ⁽²⁾		08800-5051-20XX
Remote Mounting Hardware (Excluding Cable)		08800-5055-0002
Remote Mounting Cables (Includes Cable with End Assemblies Installed)		
10 ft. (3,0m) Cable		08800-5045-2010
20 ft. (6,1m) Cable		08800-5045-2020
30 ft. (9,1m) Cable		08800-5045-2030
Cable with Customer-Specified Cable Length. Up to 75 ft. (23 m). ⁽²⁾		08800-5045-20XX
Integral Mounting Kit		
(Includes All Parts Needed to Retrofit a Remote Meter to Mount the Electronics Integrally)		08800-5639-0002
ASME Wafer Alignment Rings (Two Required)		
1/2 in. (15 mm): ASME B16.5 (ANSI) Class 150, 300, and 600 Flanges		08800-0521-0001
1 in. (25 mm): ASME B16.5 (ANSI) Class 150, 300, and 600 Flanges		08800-1021-0001
1 1/2 in. (40 mm): ASME B16.5 (ANSI) Class 150, 300, and 600 Flanges		08800-1521-0001
2 in. (50 mm): ASME B16.5 (ANSI) Class 150, 300, and 600 Flanges		08800-2021-0001
3 in. (80 mm): ASME B16.5 (ANSI) Class 150, 300, and 600 Flanges		08800-3021-0001
4 in. (100 mm): ASME B16.5 (ANSI) Class 150, 300, and 600 Flanges		08800-4021-0001
4 in. (100 mm): ASME B16.5 (ANSI) Class 600 Flanges		08800-4021-0002
6 in. (150 mm): ASME B16.5 (ANSI) Class 150 and 300 Flanges		08800-6021-0001
6 in. (150 mm): ASME B16.5 (ANSI) Class 600 Flanges		08800-6021-0002
8 in. (200 mm): ASME B16.5 (ANSI) Class 150 and 300 Flanges		08800-6221-0001
8 in. (200 mm): ASME B16.5 (ANSI) Class 600 Flanges		08800-6221-0002

(1) One spare part is recommended for every 25 flowmeters in Category A, and 50 flowmeters in Category B

(2) XX=Customer specified length in feet

Rosemount Model 8800C Vortex Flowmeter

Part Description	Part Number
DIN Wafer Alignment Rings (Two Required)	
1/2 in. (15 mm): DIN PN 10/16, 25/40, 64 and 100 Flanges	08800-0523-0001
1 in. (25 mm): DIN PN 10/16, 25/40, 64 and 100 Flanges	08800-1023-0001
1 1/2 in. (40 mm): DIN PN 10/16, 25/40, 64 and 100 Flanges	08800-1523-0001
2 in. (50 mm): DIN PN 10/16, 25/40, 64 and 100 Flanges	08800-2023-0001
3 in. (75 mm): DIN PN 10/16, 25/40, 64 and 100 Flanges	08800-3023-0001
4 in. (100 mm): DIN PN 10/16 and 64 Flanges	08800-4023-0001
4 in. (100 mm): DIN PN 25/40 and 100 Flanges	08800-4023-0002
6 in. (150 mm): DIN PN 10/16 and 64 Flanges	08800-6023-0001
6 in. (150 mm): DIN PN 25/40 and 100 Flanges	08800-6023-0002
8 in. (200 mm): DIN PN 10/16 Flanges	08800-6223-0001
8 in. (200 mm): DIN PN 25/40 Flanges	08800-6223-0002
8 in. (200 mm): DIN PN 64/100 Flanges	08800-6223-0003
JIS Wafer Alignment Rings (Two Required)	
1/2 in. (15 mm): JIS 10k, 20k, 40k	08800-0524-0001
1 in. (25 mm): JIS 10k, 20k, 40k	08800-1024-0001
1 1/2 in. (40 mm): JIS 10k, 20k, 40k	08800-1524-0001
2 in. (50 mm): JIS 10k, 20k	08800-2024-0001
2 in. (50 mm): JIS 40k	08800-2024-0002
3 in. (80 mm): JIS 10k	08800-3024-0001
3 in. (80 mm): JIS 20k, 40k	08800-3024-0002
4 in. (100 mm): JIS 10k	08800-4024-0001
4 in. (100 mm): JIS 20k, 40k	08800-4024-0002
6 in. (150 mm): JIS 10k, 20k	08800-6024-0001
6 in. (150 mm): JIS 40k	08800-6024-0002
8 in. (200 mm): JIS 10k, 20k	08800-6224-0001
8 in. (200 mm): JIS 40k	08800-6224-0002
Spacers for Model 8800C Wafer SST Meters	
(Used for maintaining 8800A face-to-face dimensions) (One Required)	
1 1/2 in. (40 mm): ASME B16.5 (ANSI) 150 to 600	08800-5711-0151
2 in. (50 mm): ASME B16.5 (ANSI) 150 to 600	08800-5711-0201
3 in. (80 mm): ASME B16.5 (ANSI) 150 to 600	08800-5711-0301
4 in. (100 mm): ASME B16.5 (ANSI) 150 to 300	08800-5711-0401
4 in. (100 mm): ASME B16.5 (ANSI) 600	08800-5711-0402

Part Description	Part Number
Spacers for Model 8800C Wafer SST Meters	
(Used for Maintaining 8800A face-to-face dimensions) (One Required)	
1½ in. (40 mm): DIN PN 10 to 100	08800-5711-0153
2 in. (50 mm): DIN PN 10 to 100	08800-5711-0203
3 in. (80 mm): DIN PN 10 to 100	08800-5711-0303
4 in. (100 mm): DIN PN 10, 16, 64	08800-5711-0403
4 in. (40 mm): DIN PN 25, 40, 1000	08800-5711-0404
Wafer Meter Body - Stainless Steel	
(Includes Stainless Steel Meter Body, Standard Range Sensor, Access Cover, and Support Tube)	
½ in.	08800-5211-0005
1 in.	08800-5211-0010
1½ in.	08800-5211-0015
2 in.	08800-5211-0020
3 in.	08800-5211-0030
4 in.	08800-5211-0040
6 in.	08800-5211-0060
8 in.	08800-5211-0080
Wafer Meter Body - Hastelloy	
(Includes Hastelloy Meter Body, Standard Range Sensor, Access Cover, and Support Tube)	
½ in.	08800-5111-1005
1 in.	08800-5111-1010
1½ in.	08800-5111-1015
2 in.	08800-5111-1020
3 in.	08800-5111-1030
4 in.	08800-5111-1040
Flanged Meter Body - Stainless Steel	
(Includes SST Meter Body, Standard Range Sensor, Access Cover, and Support Tube)	
(Consult Factory for Other Combinations)	
ASME B16.5 (ANSI) RF Class 150 Flanges	
½ in.	08800-5112-0005
1 in.	08800-5112-0010
1½ in.	08800-5112-0015
2 in.	08800-5112-0020
3 in.	08800-5112-0030
4 in.	08800-5112-0040
6 in.	08800-5112-0060
8 in.	08800-5112-0080
10 in.	08800-5112-0094
12 in.	08800-5112-0096
DN PN 16 2526 - Type D Flanges	
½ in.	08800-5112-1105
1 in.	08800-5112-1110
1½ in.	08800-5112-1115
2 in.	08800-5112-1120
3 in.	08800-5112-1130
4 in.	08800-5112-1040
6 in.	08800-5112-1060
8 in.	08800-5112-1080
10 in.	08800-5112-1094
12 in.	08800-5112-1096

Rosemount Model 8800C Vortex Flowmeter

Part Description	Part Number
ASME B16.5 (ANSI) RF Class 300 Flanges	
1/2 in.	08800-5112-0105
1 in.	08800-5112-0110
1 1/2 in.	08800-5112-0115
2 in.	08800-5112-0120
3 in.	08800-5112-0130
4 in.	08800-5112-0140
6 in.	08800-5112-0160
8 in.	08800-5112-0180
10 in.	08800-5112-0194
12 in.	08800-5112-0196
DN PN 40 2526 - Type D Flanges	
1/2 in.	08800-5112-1105
1 in.	08800-5112-1110
1 1/2 in.	08800-5112-1115
2 in.	08800-5112-1120
3 in.	08800-5112-1130
4 in.	08800-5112-1140
6 in.	088005112-1160
8 in.	08800-5112-1180
10 in.	08800-5112-1194
12 in.	08800-5112-1196
ASME B16.5 (ANSI) RF Class 600 Flanges	
1/2 in.	08800-5112-0205
1 in.	08800-5112-0210
1 1/2 in.	08800-5112-0215
2 in.	0880-5112-0220
3 in.	08800-5112-0230
4 in.	08800-5112-0240
6 in.	08800-5112-0260
8 in.	
ASME B16.5 (ANSI) RTJ Class 600 Flanges	
1/2 in.	08800-5112-2205
1 in.	08800-5112-2210
1 1/2 in.	08800-5112-2215
2 in.	08800-5112-2220
3 in.	08800-5112-2230
4 in.	08800-5112-2240
6 in.	08800-5112-2260
8 in.	08800-5112-2280

Approvals

Rosemount Drawing 08800-0111, Rev. D, 2 Sheets:
CSA Intrinsic Safety Installation Drawing for Model 8800C.

Rosemount Drawing 08800-0106, Rev. D, 3 Sheets:
Factory Mutual Intrinsic Safety Installation Drawing for Model 8800C.

PROPRIETARY INFORMATION IS CONTAINED HEREIN AND MUST BE HANDLED ACCORDINGLY BY _____ DATE _____	REVISIONS				
	REV	DESCRIPTION	CHG. NO.	APP'D	DATE
	D	REDRAWN FOR ENHANCED ELECTRONICS; 2 PAGES WAS 3.	674841	K.C.L.	6/28/96

CSA INTRINSIC SAFETY APPROVAL
ROSEMOUNT MODEL 8800 CIRCUIT CONNECTION WITH CSA APPROVED INTRINSIC SAFETY BARRIER(S).
 Ex ia
Intrinsically Safe/Sécurité Intrinsèque

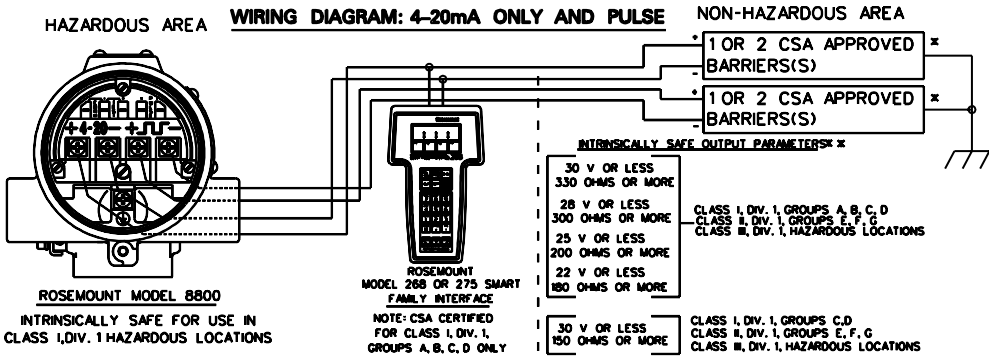
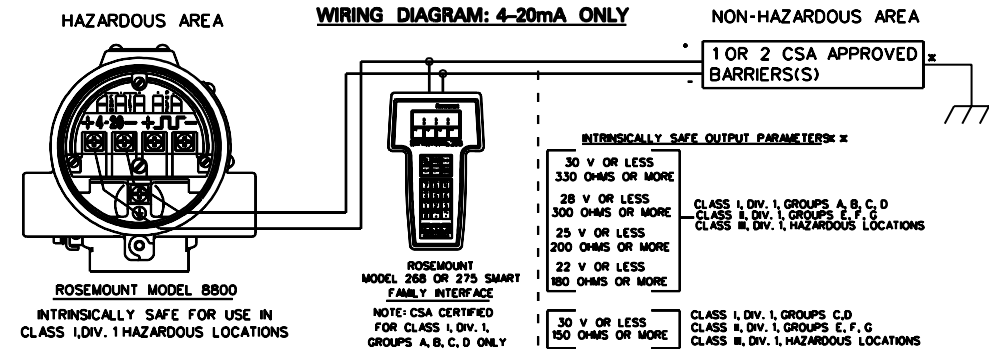

WARNING: SUBSTITUTION OF COMPONENTS MAY IMPAIR INTRINSIC SAFETY.
 AVERTISSEMENT: La Substitution de composants peut compromettre la sécurité intrinsèque.

THIS DRAWING WAS CREATED ON CAD. DRAWING IS ARCHIVED ON MAGNETIC TAPE FOR ECO CHANGES.

UNLESS OTHERWISE SPECIFIED DIMENSIONS IN INCHES. REMOVE ALL BURRS AND SHARP EDGES. MACHINE SURFACE FINISH 125 - TOLERANCES - DECIMALS FRACTIONS .X±.1 ±1/32 .XX±.02 ANGLES ±2° .XXX±.010	CONTRACT NO.	ROSEMOUNT ® Measurement Control Analytical Valves Rosemount Inc. 12001 Technology Drive Eden Prairie, MN 55344 USA	
	DR. C.SCRIBNER 2/3/93		TITLE INSTALLATION DRAWING FOR:
	CHK'D		MODEL 8800 CSA INTRINSIC SAFETY APPROVAL
	APP'D. S.McCOY 6/30/93		SIZE A FSCM NO. DWG NO. 08800-0111
	APP'D. GOVT.		SCALE N/A WT. _____ SHEET 1 OF 2

FORM NO. 60651A-1 REV. C

REVISIONS				
REV	DESCRIPTION	CHG. NO.	APP'D	DATE
D		674841		

* ALL LINES CONNECTED TO THE MODEL 8800 MUST BE TERMINATED BY EITHER A CSA APPROVED BARRIER OR AN I.S. SAFETY GROUND.

* * WHEN USING MORE THAN ONE CHANNEL OF A CSA APPROVED BARRIER, THE EFFECTIVE VOLTAGE AND RESISTANCE OF THE COMBINED LINES MUST COMPLY WITH THE LISTED INTRINSICALLY SAFE OUTPUT PARAMETERS. THE EFFECTIVE VOLTAGE AND RESISTANCE ARE TO BE CALCULATED AS FOLLOWS:

VOLTAGE: EFFECTIVE VOLTAGE = HIGHEST BARRIER VOLTAGE
 (NOTE: BOTH LINES MUST BE REFERENCED TO A COMMON GROUND)

RESISTANCE: EFFECTIVE RESISTANCE = PARALLEL COMBINATION OF EACH LINE
 (NOTE: DIODE RETURNS DO NOT NEED TO BE INCLUDED FOR THIS CALCULATION)

EXAMPLE *1: BARRIER 1: VOLTAGE = 28V; RESISTANCE = 330 OHMS
 BARRIER 2: VOLTAGE = 28V; RESISTANCE = 330 OHMS
 EFFECTIVE VOLTAGE = 28V
 EFFECTIVE RESISTANCE = $\frac{R_1 R_2}{R_1 + R_2}$ = 165 OHMS

RESULT: THIS BARRIER COMBINATION WOULD BE ACCEPTABLE FOR GROUPS C, D SINCE THE EFFECTIVE VOLTAGE IS LESS THAN OR EQUAL TO 30V AND THE EFFECTIVE RESISTANCE IS GREATER THAN OR EQUAL TO 150 OHMS.

EXAMPLE *2: BARRIER 1: VOLTAGE = 28V; RESISTANCE = 330 OHMS (4-20 "+")
 BARRIER 2: 28V DIODE RETURN (4-20 "-")
 BARRIER 3: VOLTAGE = 28V; RESISTANCE = 1000 OHMBULSE "+")
 BARRIER 4: 28V DIODE RETURN (PULSE "-")
 EFFECTIVE VOLTAGE = 28V
 EFFECTIVE RESISTANCE = $\frac{1}{\frac{1}{R_1} + \frac{1}{R_2} + \frac{1}{R_3} + \frac{1}{R_4}}$ = 248 OHMS

RESULT: THIS BARRIER COMBINATION WOULD BE ACCEPTABLE FOR GROUPS C, D SINCE THE EFFECTIVE VOLTAGE IS LESS THAN OR EQUAL TO 30V AND THE EFFECTIVE RESISTANCE IS GREATER THAN OR EQUAL TO 150 OHMS.

Rosemount Inc. 12001 Technology Drive Eden Prairie, MN 55344 USA	THIS DRAWING WAS CREATED ON CAD. DRAWING IS ARCHIVED ON MAGNETIC TAPE FOR ECO CHANGES.		
DR. D.MALINOWSKI	SIZE A	FSCM NO	DWG NO. 08800-0111
ISSUED	SCALE N/A	WT. _____	SHEET 2 OF 2

FORM NO. 60651A-1 REV. C

Rosemount Model 8800C Vortex Flowmeter

PROPRIETARY INFORMATION IS CONTAINED HEREIN AND MUST BE HANDLED ACCORDINGLY BY _____ DATE _____		REVISIONS			
REV	DESCRIPTION	CHG. NO.	APP'D	DATE	
D	REDRAWN FOR ENHANCED ELECTRONICS; CHG C ₁ TO 0; 3 PAGES WAS 4	674061	K.C.L.	5/22/96	

FMRC INTRINSIC SAFETY APPROVAL

THE ROSEMOUNT MODEL 8800 SMART VORTEX FLOWMETER IS FMRC APPROVED AS INTRINSICALLY SAFE WHEN INSTALLED PER THE NATIONAL ELECTRIC CODE (NEC) ARTICLE 504 WITH FMRC APPROVED ASSOCIATED APPARATUS WHICH MEETS THE ENTITY PARAMETERS INDICATED BELOW. ADDITIONALLY, THE ROSEMOUNT MODEL 751 FIELD SIGNAL INDICATOR IS FMRC APPROVED AS INTRINSICALLY SAFE WHEN CONNECTED IN CIRCUIT WITH THE ROSEMOUNT MODEL 8800 AS SPECIFIED IN THIS DRAWING.

INTRINSICALLY SAFE FOR CLASS I, DIV. 1, GROUPS A, B, C, D; CLASS II, DIV. 1, GROUPS E, F, G; CLASS III, DIV. 1 HAZARDOUS LOCATIONS.

TERMINALS "+", "-", AND "4-20 mA"	ASSOCIATED APPARATUS PARAMETERS
V _{max} = 30Vdc I _{max} = 300mA C _i = 0μF L _i = 40μH	V _{oc} OR V _t ≤ 30V I _{sc} OR I _t ≤ 300mA C _o > C _{cable} + C _i L _o > L _{cable} + L _i

NOTE: ENTITY PARAMETERS LISTED APPLY ONLY TO ASSOCIATED APPARATUS WITH LINEAR OUTPUTS

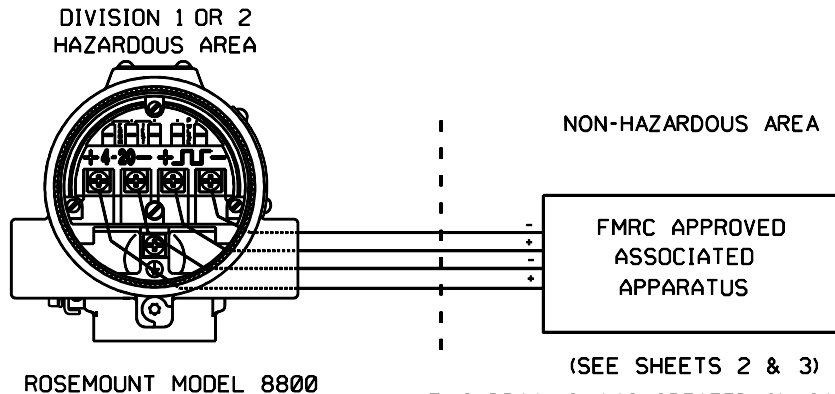

THIS DRAWING WAS CREATED ON CAD. DRAWING IS ARCHIVED ON MAGNETIC TAPE FOR ECO CHANGES.

UNLESS OTHERWISE SPECIFIED DIMENSIONS IN INCHES. REMOVE ALL BURRS AND SHARP EDGES. MACHINE SURFACE FINISH 125 - TOLERANCES - DECIMALS FRACTIONS .X±.1 ±1/32 .XX±.02 ANGLES ±2° .XXX±.010	CONTRACT NO.	ROSEMOUNT Measurement Control Analytical Valves Rosemount Inc. 12001 Technology Drive Eden Prairie, MN 55344 USA
	DR. C.SCRIBNER 2/13/93	
	CHK'D	TITLE INSTALLATION DRAWING FOR: MODEL 8800 FM INTRINSIC SAFETY FIELD CIRCUIT CONFIGURATIONS
	APP'D. S.M.COY 5/14/93	SIZE FSCM NO DWG NO. 08800-0106
DO NOT SCALE PRINT	APP'D. GOVT.	SCALE N/A WT. _____ SHEET 1 OF 3

FORM NO. 60651A-1 REV. C

REVISIONS				
REV	DESCRIPTION	CHG. NO.	APP'D	DATE
D		674061		

FIELD CIRCUIT CONFIGURATION DIAGRAM 1
ONE BARRIER OR CONVERTER:
SINGLE OR DUAL CHANNEL

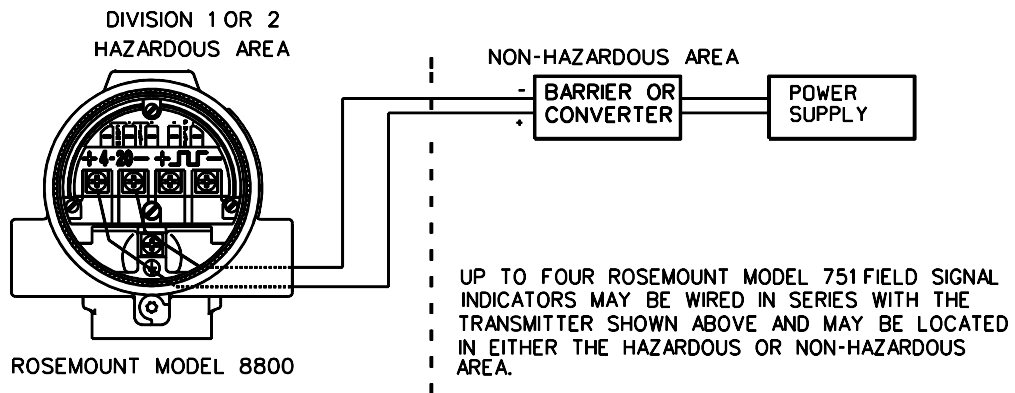

FIELD CIRCUIT CONFIGURATION DIAGRAM II
SUPPLY AND RETURN BARRIERS
(ONLY FOR USE WITH BARRIERS APPROVED IN THIS CONFIGURATION)

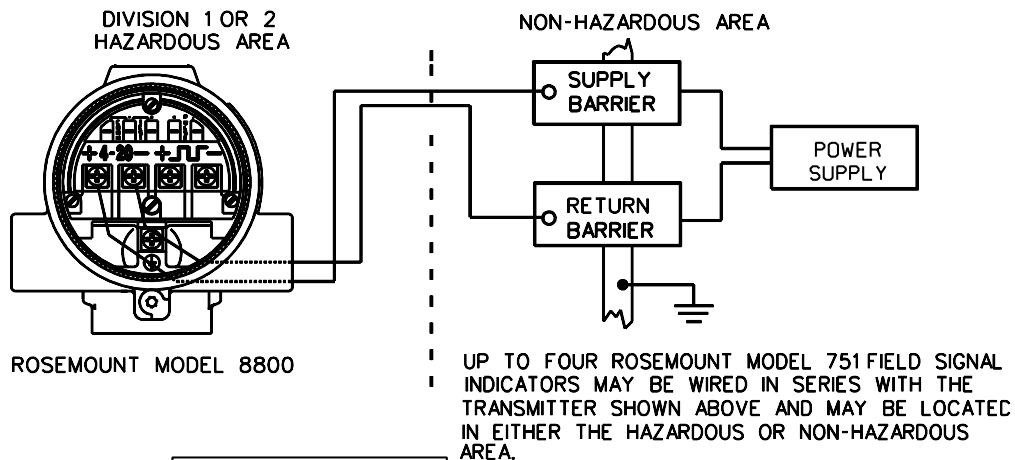

Rosemount Inc.
12001 Technology Drive
Eden Prairie, MN 55344 USA

THIS DRAWING WAS CREATED ON CAD. DRAWING IS ARCHIVED ON MAGNETIC TAPE FOR ECO CHANGES.

DR. C.SCRIBNER	SIZE A	FSCM NO	DWG NO. 08800-0106
ISSUED	SCALE N/A	WT.	SHEET 2 OF 3

FORM NO. 60651A-1 REV. C

Rosemount Model 8800C Vortex Flowmeter

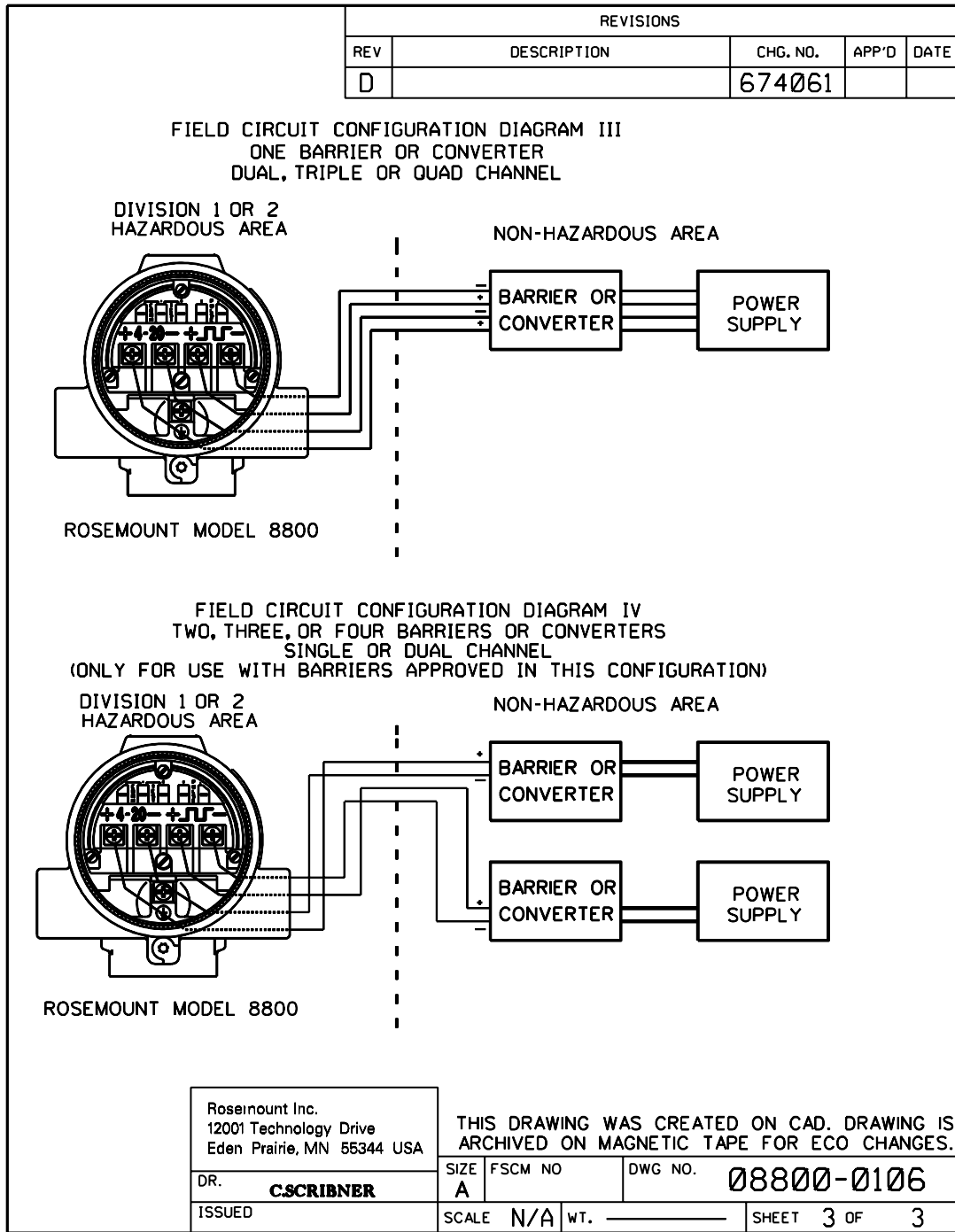

FORM NO. 60651A-1 REV. C

C

HART Communicator

Connections and Hardware page C-6

Rosemount Model 8800C Vortex Flowmeter

Figure C-1. HART Communicator Menu Tree for Model 8800C* and Model 8800A

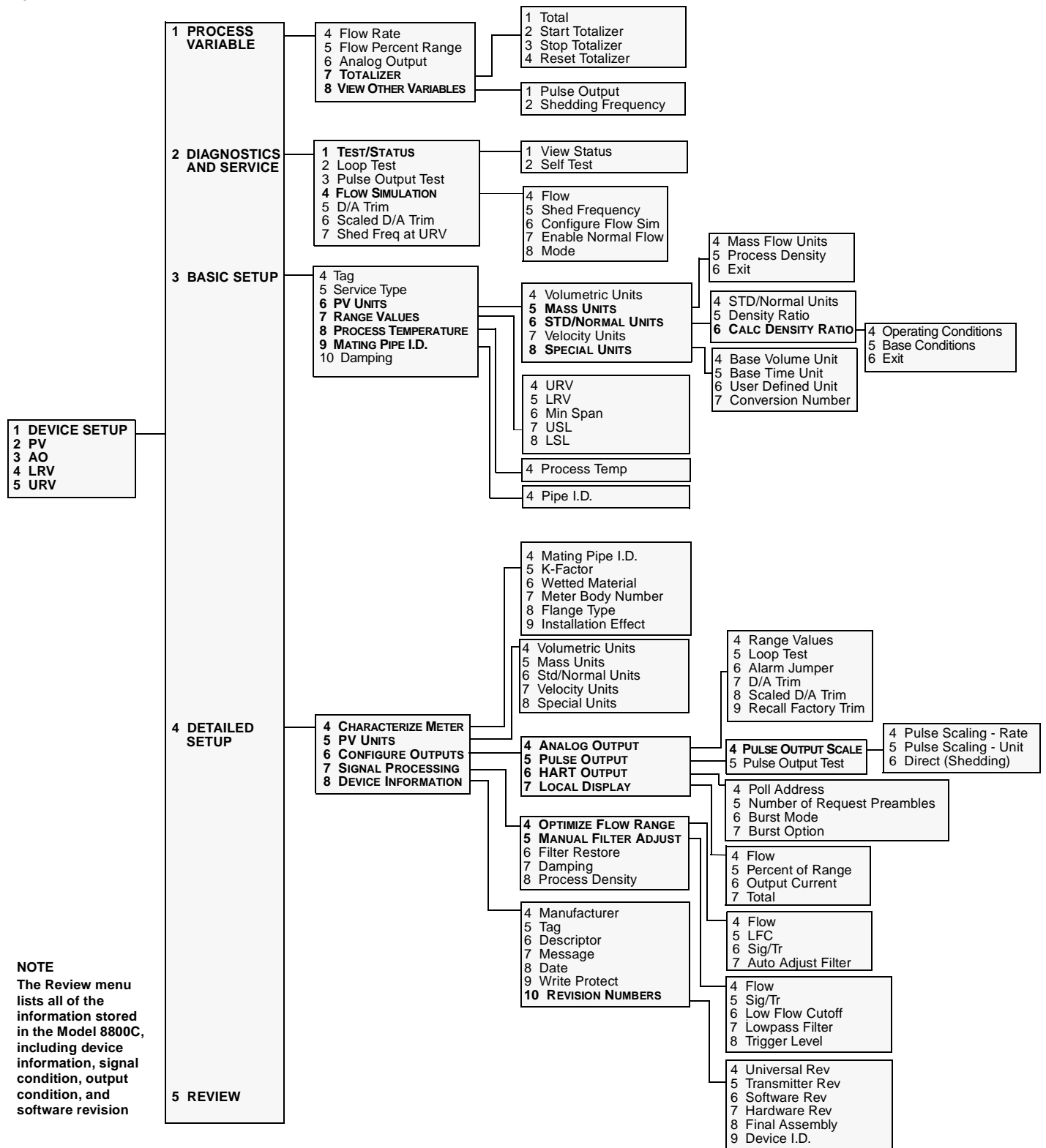

Table C-1. HART Fast Key Sequences for Model 8800C* and Model 8800A

Function	HART Fast Keys	Function	HART Fast Keys
Alarm Jumper	1, 4, 3, 1, 3	Poll Address	1, 4, 3, 3, 1
Analog Output	1, 4, 3, 1	Process Density ⁽¹⁾	1, 3, 3, 2, 2 or 1, 4, 4, 5
Base Conditions	1, 3, 3, 3, 3, 2	Process Temperature	1, 3, 5
Base Time Unit	1, 3, 3, 5, 2	Process Variables	1, 1
Base Volume Unit	1, 3, 3, 5, 1	Pulse Output	1, 4, 3, 2
Burst Mode	1, 4, 3, 3, 3	Pulse Output Scale	1, 4, 3, 2, 1
Burst Option	1, 4, 3, 3, 4	Pulse Output Test	1, 2, 3 or 1, 4, 3, 2, 2
Characterize Meter	1, 4, 1	PV Percent Range	1, 1, 2
Conversion Number	1, 3, 3, 5, 4	PV Units	1, 3, 3
D/A Trim	1, 2, 5 or 1, 4, 3, 1, 4	Range Values	1, 3, 4
Damping	1, 3, 7	Review	1, 5
Date	1, 4, 5, 5	Revision Numbers	1, 4, 5, 7
Descriptor	1, 4, 5, 3	Scaled D/A Trim	1, 2, 6 or 1, 4, 3, 1, 5
Density Ratio	1, 3, 3, 3, 2	Self Test	1, 2, 1, 2
Device ID	1, 4, 5, 7, 6	Service Type	1, 3, 2
Device Information	1, 4, 5	Wetted Material	1, 4, 1, 3
Filter Restore	1, 4, 4, 3	Shedding Frequency	1, 4, 3, 2, 1, 3
Final Assembly Number	1, 4, 5, 7, 5	Signal Processing	1, 4, 4
Flange Type	1, 4, 1, 5	Software Rev	1, 4, 5, 7, 3
Hardware Rev	1, 4, 5, 7, 4	Special Units	1, 3, 3, 5
HART Output	1, 4, 3, 3	Status	1, 2, 1, 1
K-Factor	1, 4, 1, 2	Tag	1, 3, 1
Local Display	1, 4, 3, 4	Total	1, 1, 4, 1
Loop Test	1, 2, 2 or 1, 4, 3, 1, 2	Totalizer Control	1, 1, 4
Low Flow Cutoff	1, 4, 4, 1, 2 or 1, 4, 4, 2, 3	Transmitter Test	1, 2, 1, 2
Low Pass Filter	1, 4, 4, 2, 4	Trigger Level	1, 4, 4, 2, 5
LRV	1, 3, 4, 2	Universal Rev	1, 4, 5, 7, 1
LSL	1, 3, 4, 5	URV	1, 3, 4, 1
Manufacturer	1, 4, 5, 1	User Defined Units	1, 3, 3, 5, 3
Mass Units	1, 3, 3, 2, 1	USL	1, 3, 4, 4
Mating Pipe ID (Inside Diameter)	1, 3, 6	Velocity Units	1, 3, 3, 4
Message	1, 4, 5, 4	Volumetric Units	1, 3, 3, 1
Meter Body Number	1, 4, 1, 4	Wetted Material	1, 4, 1, 3
Minimum Span	1, 3, 4, 3	Write Protect	1, 4, 5, 6
Num Req Preams	1, 4, 3, 3, 2		

(1) Process density is only available when mass flow units are selected.

*Figure C-1 and Table C-1 are the latest versions of the Model 8800C and Model 8800A Menu Tree and Fast Key codes. If you are not sure which version you have, hook up your HART Communicator and go to the Basic Setup menu.

If the Basic Setup menu on your communicator does not match the menu in Figure C-1 on page C-2, refer to page C-4 for the correct Menu Tree and page C-5 for the correct Fast Key codes.

Rosemount Model 8800C Vortex Flowmeter

Figure C-2. HART Communicator Menu Tree for Model 8800*

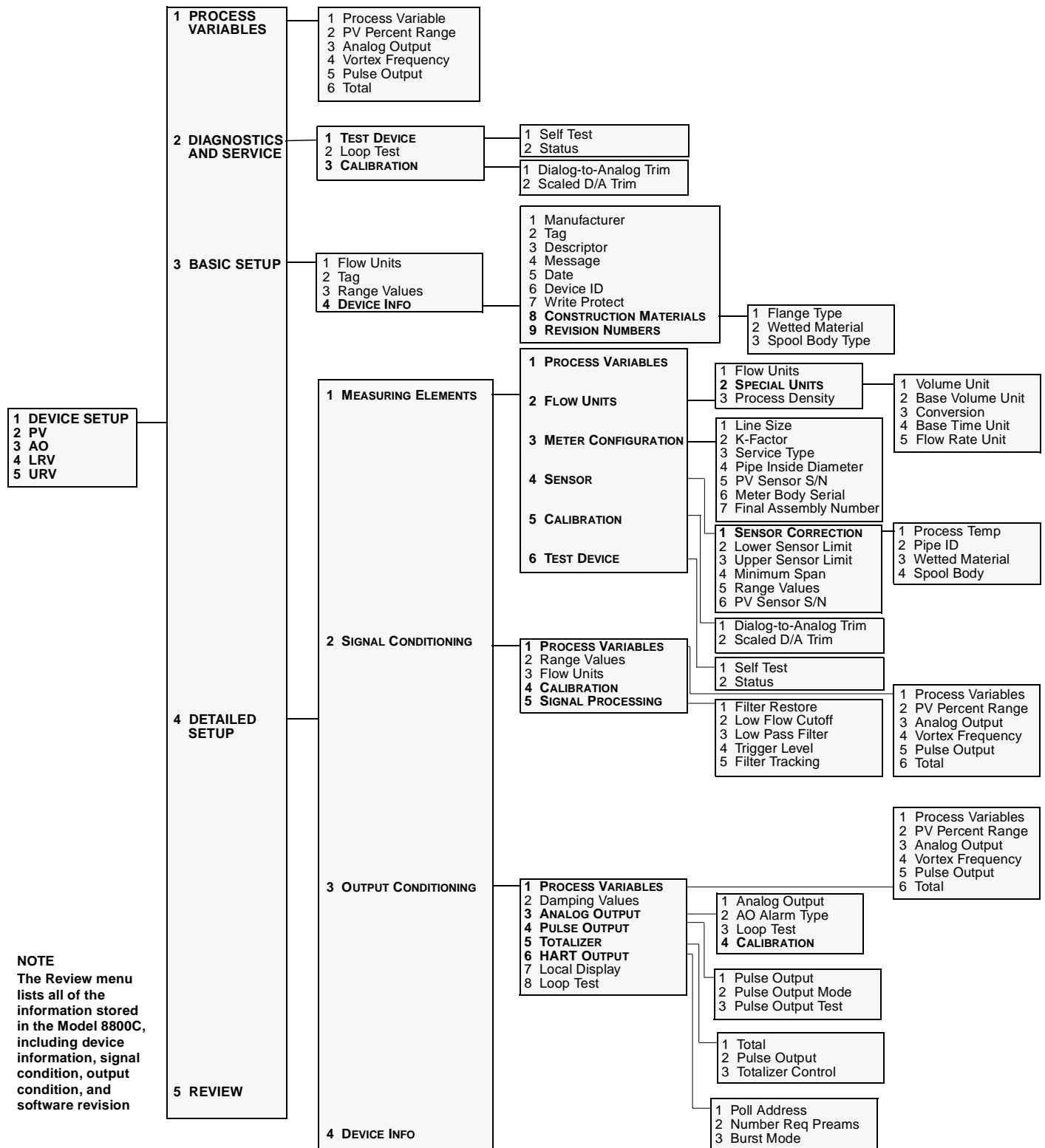

Table C-2. HART Fast Key Sequences for Model 8800*

Function	HART Fast Keys	Function	HART Fast Keys
Analog Output	1, 1, 3	Num Req Preams	1, 4, 3, 6, 2
AO Alarm Type	1, 4, 3, 3, 2	Pipe Inside Diameter	1, 4, 1, 3, 4
Base Time Unit	1, 4, 1, 2, 2, 4	Poll Address	1, 4, 3, 6, 1
Base Volume Unit	1, 4, 1, 2, 2, 4	Process Density ⁽¹⁾	1, 4, 1, 2, 3
Burst Mode	1, 4, 3, 6, 3, 2	Process Temperature	1, 4, 1, 4, 1, 1
Burst Option	1, 4, 3, 6, 3, 1	Process Variables	1, 1
Conversion Factor	1, 4, 1, 2, 2, 3	Pulse Output	1, 1, 5
D/A Trim	1, 2, 3, 1	Pulse Output Mode	1, 4, 3, 4, 2
Damping Value	1, 4, 3, 2	Pulse Output Test	1, 2, 2, 2
Date	1, 3, 4, 5	PV Percent Range	1, 1, 2
Descriptor	1, 3, 4, 3	PV Sensor Serial Number	1, 4, 1, 3, 5
Device ID	1, 3, 4, 6	Range Values	1, 3, 3
Filter Restore	1, 4, 2, 5, 1	Review	1, 5
Filter Tracking	1, 4, 2, 5, 5	Revision Numbers	1, 3, 4, 9
Final Assembly Number	1, 4, 1, 3, 7	Scaled D/A Trim	1, 2, 3, 2
Flange Type	1, 3, 4, 8, 1	Self Test	1, 2, 1, 1
Flow Rate Unit	1, 4, 1, 2, 2, 5	Service Type	1, 4, 1, 3, 3 1, 3, 2
Flow Units	1, 3, 1	Special Units	1, 4, 1, 2, 2
K-Factor	1, 4, 1, 3, 2	Spool Body Type	1, 3, 4, 8, 3
Line Size	1, 4, 1, 3, 1	Status	1, 2, 1, 2
Local Display	1, 4, 3, 7	Tag	1, 3, 2
Loop Test	1, 2, 2, 1	Total	1, 1, 6
Low Flow Cutoff	1, 4, 2, 5, 2	Totalizer Control	1, 4, 3, 5, 3
Low Pass Filter Corner	1, 4, 2, 5, 3	Transmitter Test	1, 2, 1, 1
LRV	1, 3, 3, 2	Trigger Level	1, 4, 2, 5, 4
LSL	1, 4, 1, 4, 2	URV	1, 3, 3, 1
Manufacturer	1, 3, 4, 1	USL	1, 4, 1, 4, 3
Message	1, 3, 4, 4	Vol Unit	1, 4, 1, 2, 2, 1
Meter Body Serial Number	1, 4, 1, 3, 6	Vortex Frequency	1, 1, 4
Minimum Span	1, 4, 1, 4, 4	Wetted Materials	1, 3, 4, 8, 2
		Write Protect	1, 3, 4, 7

(1) Process density is only available when mass flow units are selected.

CONNECTIONS AND HARDWARE

The HART Communicator exchanges information with the transmitter from the control room, the instrument site, or any wiring termination point in the loop. The HART Communicator should be connected in parallel with the transmitter.

⚠ WARNING

Explosions can result in death or serious injury. Before connecting the HART Communicator in an explosive atmosphere, make sure the instruments in the loop are installed in accordance with intrinsically safe or nonincendive field wiring practices.

Figure C-3. Connecting the HART Communicator to a Transmitter Loop

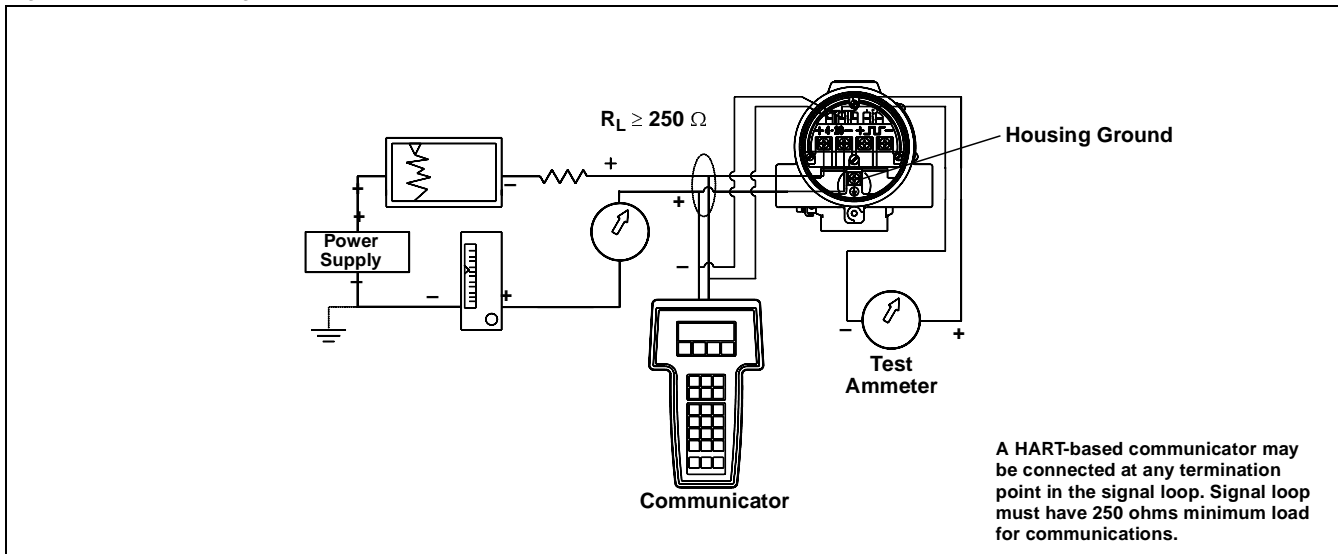

NOTE

The HART Communicator needs a minimum of 250 ohms resistance in the loop to function properly. The HART Communicator does not measure loop current directly.

Diagnostic Messages

The following is a list of messages used by the HART Communicator (HC) and their corresponding descriptions. Variable parameters within the text of a message are indicated with *<variable>*.

The following error/warning messages are applicable only to the Model 8800C and Model 8800A Vortex Flowmeters.

Message	Description
Add item for ALL device types or only for this ONE device type.	Asks the user whether the hot key item being added should be added for all device types or only for the type of device that is connected.
Command not implemented.	The connected device does not support this function.
Communication error.	Either a device sends back a response indicating that the message it received was unintelligible, or the HC cannot understand the response from the device.
Configuration memory not compatible with connected device.	The configuration stored in memory is incompatible with the device to which a transfer has been requested.
Device busy.	The connected device is busy performing another task.
Device disconnected.	Device fails to respond to a command.
Device write protected.	Device is in write-protect mode. Data can not be written.
Device write protected. Do you still want to shut off?	Device is in write-protect mode. Press YES to turn the HC off and lose the unsent data.
Display value of variable on hotkey menu?	Asks whether the value of the variable should be displayed adjacent to its label on the hotkey menu if the item being added to the hotkey menu is a variable.
Download data from configuration memory to device.	Prompts user to press SEND softkey to initiate a memory to device transfer.
Exceed field width.	Indicates that the field width for the current arithmetic variable exceeds the device- specified description edit format.
Exceed precision.	Indicates that the precision for the current arithmetic variable exceeds the device- specified description edit format.
Ignore next 50 occurrences of status?	Asked after displaying device status. Softkey answer determines whether next 50 occurrences of device status will be ignored or displayed.
Illegal character.	An invalid character for the variable type was entered.
Illegal date.	The day portion of the date is invalid.
Illegal month.	The month portion of the date is invalid.
Illegal year.	The year portion of the date is invalid.
Incomplete exponent.	The exponent of a scientific notation floating point variable is incomplete.
Incomplete field.	The value entered is not complete for the variable type.
Looking for a device.	Polling for multidropped devices at addresses 1–15.
Mark as read only variable on hotkey menu?	Asks whether the user should be allowed to edit the variable from the hotkey menu if the item being added to the hotkey menu is a variable.
No device configuration in configuration memory.	There is no configuration saved in memory available to re-configure off-line or transfer to a device.
No device found.	Poll of address zero fails to find a device, or poll of all addresses fails to find a device if auto-poll is enabled.
No hotkey menu available for this device.	There is no menu named "hotkey" defined in the device description for this device.
No offline devices available.	There are no device descriptions available to be used to configure a device offline.
No simulation devices available.	There are no device descriptions available to simulate a device.
No UPLOAD_VARIABLES in ddl for this device.	There is no menu named "upload_variables" defined in the device description for this device. This menu is required for offline configuration.
No valid items.	The selected menu or edit display contains no valid items.
OFF KEY DISABLED.	Appears when the user attempts to turn the HC off before sending modified data or before completing a method.

Rosemount Model 8800C Vortex Flowmeter

Message	Description
Online device disconnected with unsent data. RETRY or OK to lose data.	There is unsent data for a previously connected device. Press RETRY to send data, or press OK to disconnect and lose unsent data.
Out of memory for hotkey configuration. Delete unnecessary items.	There is no more memory available to store additional hot key items. Unnecessary items should be deleted to make space available.
Overwrite existing configuration memory.	Requests permission to overwrite existing configuration either by a device-to-memory transfer or by an offline configuration. User answers using the soft keys.
Press OK.	Press the OK soft key. This message usually appears after an error message from the application or as a result of HART communications.
Restore device value?	The edited value that was sent to a device was not properly implemented. Restoring the device value returns the variable to its original value.
Save data from device to configuration memory.	Prompts user to press SAVE softkey to initiate a device-to-memory transfer.
Saving data to configuration memory.	Data is being transferred from a device to configuration memory.
Sending data to device.	Data is being transferred from configuration memory to a device.
There are write only variables which have not been edited. Please edit them.	There are write-only variables which have not been set by the user. These variables should be set or invalid values may be sent to the device.
There is unsent data. Send it before shutting off?	Press YES to send unsent data and turn the HC off. Press NO to turn the HC off and lose the unsent data.
Too few data bytes received.	Command returns fewer data bytes than expected as determined by the device description.
Transmitter fault.	Device returns a command response indicating a fault with the connected device.
Units for <label> has changed. Unit must be sent before editing, or invalid data will be sent.	The engineering units for this variable have been edited. Send engineering units to the device before editing this variable.
Unsent data to online device. SEND or LOSE data.	There is unsent data for a previously connected device which must be sent or thrown away before connecting to another device.
Use up/down arrows to change contrast. Press DONE when done.	Gives direction to change the contrast of the HC display.
Value out of range.	The user-entered value is either not within the range for the given type and size of variable or not within the min/max specified by the device.
<message> occurred reading/writing <label>	Either a read/write command indicates too few data bytes received, transmitter fault, invalid response code, invalid response command, invalid reply data field, or failed pre- or post-read method; or a response code of any class other than SUCCESS is returned reading a particular variable.
<label> has an unknown value. Unit must be sent before editing, or invalid data will be sent.	A variable related to this variable has been edited. Send related variable to the device before editing this variable.

The following error/warning messages are applicable only to the Model 8800C and Model 8800A Vortex Flowmeters.

Message	Description
ROM CHECKSUM ERROR	The EPROM memory checksum test has failed. The transmitter will remain in ALARM until the ROM checksum test passes.
EEPROM CHECKSUM ERROR	The User Configuration area in Nonvolatile EEPROM memory has failed the checksum test. It is possible to repair this checksum by verifying and reconfiguring ALL transmitter parameters. The transmitter will remain in ALARM until the EEPROM checksum test passes.
RAM TEST ERROR	Transmitter RAM memory test has detected a failed RAM location. The transmitter will remain in ALARM until the RAM test passes.
ASIC INTERRUPT ERROR	This error is not currently used in the Model 8800C. It should not appear on the 275.
DIGITAL FILTER ERROR	The digital filter in the transmitter electronics is not reporting. The transmitter will remain in ALARM until the digital signal processor resumes reporting flow data.
COPROCESSOR ERROR	If this occurs at power-up, the RAM/ROM test in the coprocessor has failed. If this occurs during normal operations, the coprocessor has reported either a math error or a negative flow. This is a FATAL error and the transmitter will remain in ALARM until reset.
SOFTWARE DETECTED ERROR	The software has detected corrupted memory. One or more of the software tasks has corrupted memory. This is a FATAL error and the transmitter will remain in ALARM until reset.
ELECTRONICS FAILURE	This is a summary error indication. This error will be reported if any of the following error conditions are present: <ol style="list-style-type: none"> 1. ROM Checksum Error 2. EEPROM Checksum Error 3. RAM Test Error 4. ASIC Interrupt Error 5. Digital Filter Error 6. Coprocessor Error 7. Software Detected Error
TRIGGER LEVEL OVERRANGE	The trigger level in the transmitter digital signal processing has been set beyond its limit. Use manual filter adjustment to "Increase Filtering" or "Increase Sensitivity" to bring the trigger level back within range.
LOW PASS FILTER OVERRANGE	The low flow cutoff in the transmitter digital signal processing has been set beyond its limit. Use manual filter adjustment to "Increase Range" or "Decrease No Flow Noise" to bring the low flow cutoff adjustment back within range.
AMBIENT TEMP OVERRANGE	The electronics temperature sensor within the transmitter is reporting a value out of range.
PARAMETERS NOT CONFIGURED	Certain configuration parameters are out of range. either they have not been properly configured, or they have been forced out of range as a result of a change to a related parameter. For example: When using mass flow units, changing the process density to a value too low could push the configured Upper Range Value beyond the sensor limit. In this case, the Upper Range Value would need to be reconfigured.
FACTORY EEPROM CONFIG ERROR	The factory configured values in non-volatile EEPROM memory have become corrupted. This is a FATAL error. The transmitter will remain in ALARM until reset.

Model 268 Communicator

Figure D-1. Model 268 Menu Tree

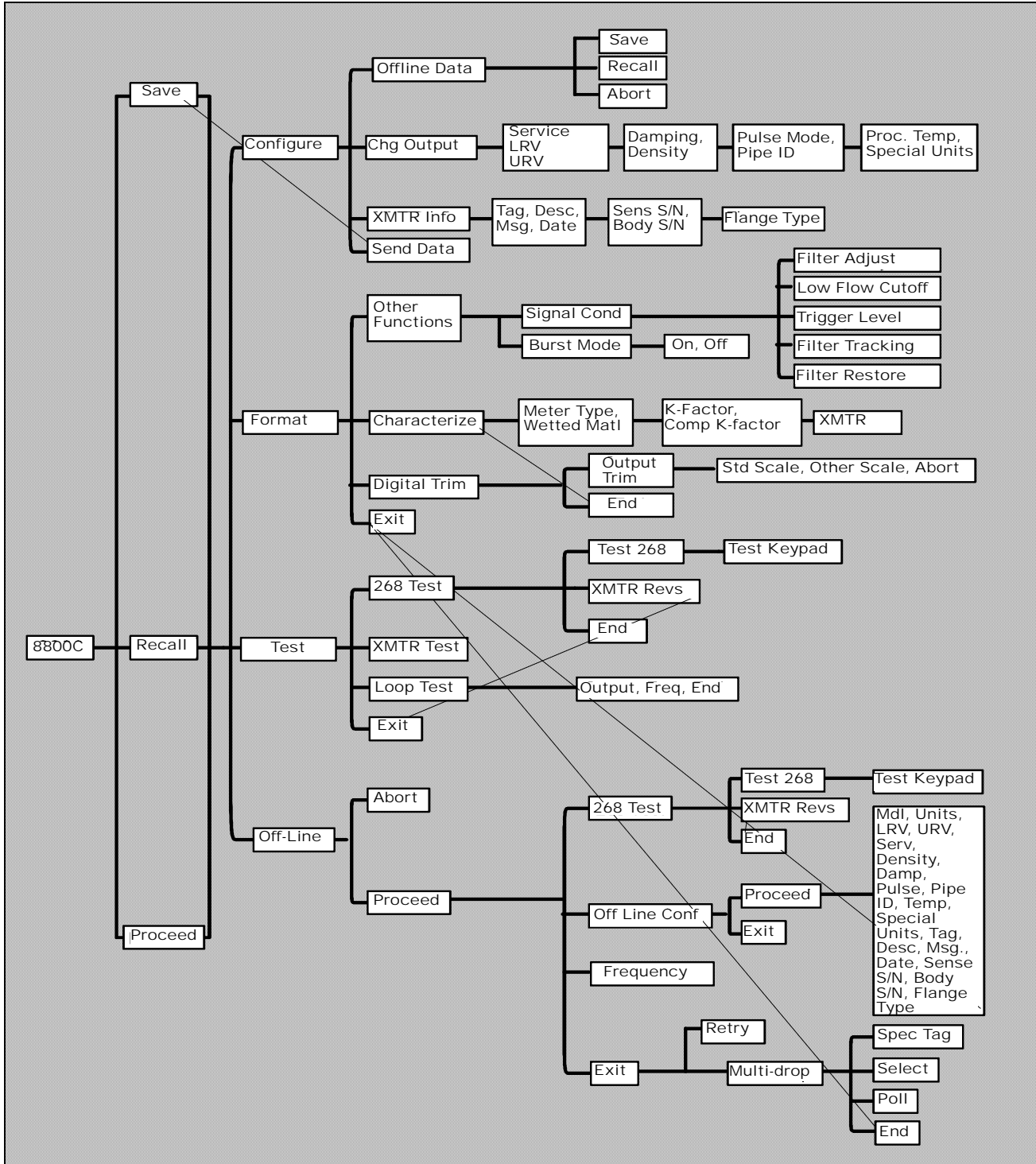

Rosemount Model 8800C Vortex Flowmeter

Table D-1. Model 268 Fast Key Equivalents

Function	Model 268 Fast Keys
Analog Output	*
AO Alarm Type	*
Base Time Unit	F3,F2,(8X)F1
Base Volume Unit	F3,F2,(8X)F1
Burst Mode	F4,F4,F1,(F1)
Burst Option	F4,F4,F1,(F1)
Conversion Number	F3,F2,(8X)F1
D/A Trim	F4,F4,F3,F1,F1
Damping Values	F3,F2,(3X)F1
Date	F3,F3,(3X)F1
Descriptor	F3,F3,F1
Dev Id	*
Filter Restore	F4,F4,F1,(F1)
Filter Tracking	F4,F4,F1,(F1)
Final Assembly Number	F4,F4,F2,(3X)F4
Flange Type	F3,F3,(6X)F1
Flow Rate Unit	F3,F2,(8X)F1
Flow Units	F3,F2
K-factor	F4,F4,F2,F4,F4
Line Size	*
Local Display	*
Loop Test	F2,F3,F4
Low Flow Cutoff	F4,F4,F1,(F1)
Lowpass Filter Corner	F4,F4,F1,(F1)
LRV	*
LSL	*
Manufacturer	*
Message	F3,F3,F1,F1
Meter Body Serial Number	F3,F3,(5X)F1
Minimum Span	*
Num Req Preams	*
Pipe ID (Inside Diameter)	F3,F2,(6X)F1
Poll Address	OFF LINE FCN
Process Density	F3,F2,F1,F1,F1
Process Temperature	F3,F2,(7X)F1
Process Variables	PV KEY
Pulse Output	F3,F2,(5X)F1
Pulse Output Mode	F3,F2,(4X)F1
Pulse Output Test	F2,F3,F4,F1
PV Percent Range	
PV Sensor Serial Number	F3,F3,(4X)F1
Range Values	F3,F2,F1
Review	REVIEW KEY
Revision Numbers	*
Scaled D/A Trim	F4,F4,F3,F1,F2
Service Type	F3,F2,F1,F1
Self Test	F2, F2
Spool Body Type	F4,F4,F2
Status	*
Tag	F3,F3
Total	PV KEY,F3
Totalizer Control	PV KEY, F3
Transmitter Test	F2,F2
Trigger Level	F4,F4,F1,(F1)
URV	*
USL	*
Vol Unit	F3,F2,(8X)F1
Vortex Frequency	
Wetted Materials	F4,F4,F2,F4
Write Protect	*

**CONNECTIONS
AND HARDWARE**

The Model 268 can communicate with a transmitter from the control room, the transmitter site, or any other wiring termination point in the loop. To communicate, it must be connected in parallel with the transmitter; the connections are non-polarized.

NOTES

The HART Communicator needs a minimum of 250 ohms resistance in the loop to function properly. The HART Communicator does not measure loop current directly.

The Model 268 cannot measure loop current directly.

Figure D-2. Connecting the Model 268 to a Transmitter Loop

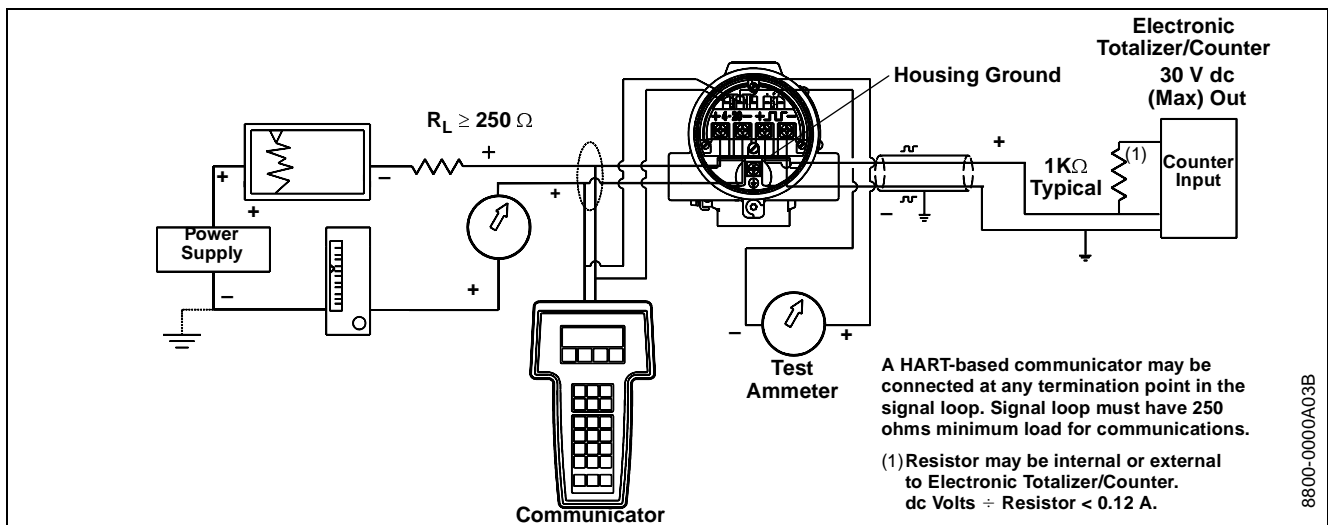
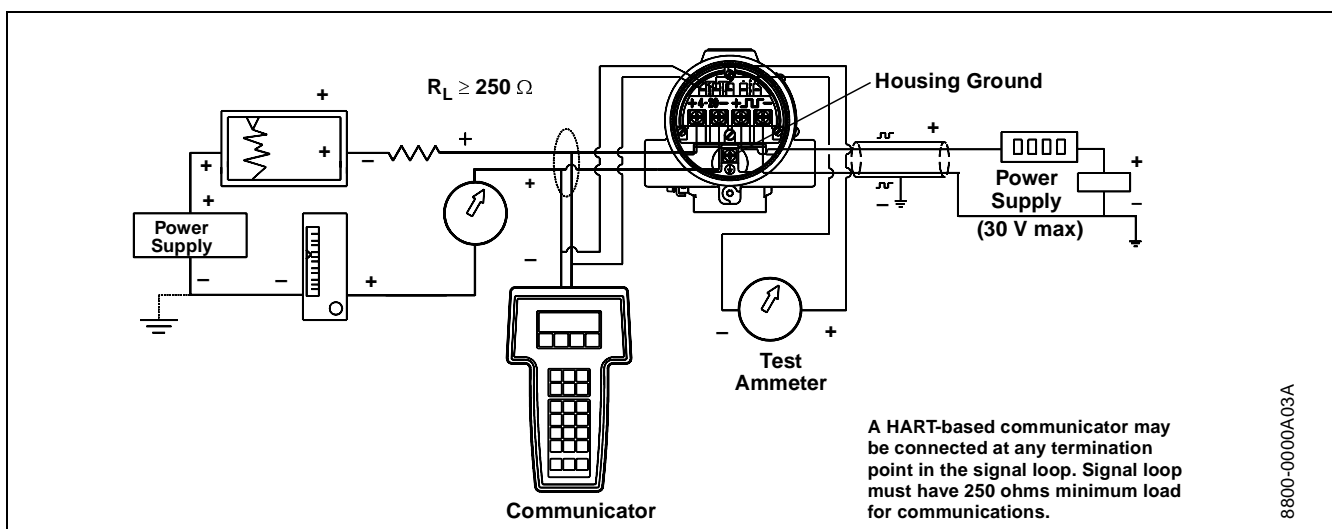

Figure D-4. Connecting the Model 268 to a Transmitter Loop



Diagnostics Messages

The following table provides a guide to diagnostic messages of the Model 268.

Message	Description
CAUTION —Progressing will clear OFLN Mem. Data saved in OFLN Mem for downloading.	OFLN Memory is cleared for new information. Off-line configuration data are saved in the Off-line Memory and can be downloaded or sent to the flowmeter at an appropriate time.
Different XMTR type connected —XMTR Mem not changed.	Flowmeter did not accept data sent because the data is meant for a different type of transmitter.
End of list.	Marks the end of a list of diagnostic messages.
ERR —Filter Auto Adj.	The low pass filter auto-adjust sequence error occurs under the following conditions: <ul style="list-style-type: none"> • No flow in pipe • Erratic flowrate • Filter tracking disabled Remedy conditions and repeat function.
ERR —Hard/software is not compatible.	Flowmeter cannot interpret Model 268 message. Perform a transmitter test. If OK, make note of conditions and keystrokes leading to failure, and contact Rosemount Service Center.
ERR —Not in output mode.	Flowmeter must be in output mode to complete this operation.
ERR —Not XMTR command.	Flowmeter does not understand the command sent by the Model 268. Press F4, RESTART to restart the flowmeter, or press F3 to suppress the error message and REVIEW the software revision level. You may need to contact the Rosemount Service Center.
ERR —Out of range.	The value chosen is outside the sensor range limits. Enter an acceptable value.
ERR —PV out of limits.	The flowmeter is in a high flow rate condition or has experienced a sensor failure.
ERR —Update failure.	The Model 268 has missed several communications from the flowmeter. Check for noise on the loop and adjust filters. If no noise is present, test the Model 268 and the transmitter.
ERR —Value was too hi.	Enter an acceptable value.
ERR —Value was too lo.	Enter an acceptable value.
ERR —XMTR fault support command.	Model 268 is detecting a possible problem with the transmitter. Perform the flowmeter self-test and use the diagnostic messages to locate the problem.
ERR —XMTR will not support command.	The flowmeter does not understand the Model 268 command. Press F4, RESTART or press F3, REVIEW to review the software revision level of the flowmeter. Check compatibility.
ERR —268 Data err.	Flowmeter cannot interpret Model 268 inquiry. Perform a transmitter test. If OK, make note of conditions and keystrokes leading to failure, and contact Rosemount Service Center.
Errors Detected —XMTR Mem not changed.	Flowmeter did not accept data because it contained nonpermissible values. Data errors must be corrected and the data sent again.
FAILURE —Electronics.	The flowmeter electronics has experienced a component or software failure. Contact Field Service Center.
Gen failure —No. 1.	Flowmeter has given improper response to Model 268. Perform a transmitter test. If OK, make note of conditions and keystrokes leading to failure, and contact Rosemount Service Center.
Making changes permanent —PLEASE WAIT.	Data is being sent to flowmeter. Flowmeter is accepting the data.
No data modified to send.	Data with no changes is being sent. Press F4 to continue.
No data saved in OFLN Mem.	There is no data in the Off-line Memory to review.
No data saved in SAFE Mem.	There is no data in the Safe Memory to review.
OfIn Mem not compatible with WORK REGS —Data not transferred.	The data stored in Off-line Memory and Working Register are from different kinds of transmitters, or the Off-line Memory is empty. Press F4, REVIEW, F2 to see the data in Off-line Memory and connect the Model 268 to similar transmitter.
SAFE Mem from diff XMTR than WORK REGS —Data not transferred.	Data in the Safe Memory and Working Register are from different transmitters. Press F4, REVIEW, F2 and find the flowmeter serial number. Connect the Model 268 to the flowmeter with that serial number and press RESTART.

Message	Description
SAFE Mem not compatible with WORK REGS–Data not transferred.	The unique identifier in the Safe Memory and the transmitter are different. Press F4, REVIEW, F2 to see the data in the Safe Memory. Connect the Model 268 to the matching transmitter. Press RESTART.
WARN–Used nearest legal table value.	The value entered has too many decimal places. The Model 8800 defaults to the closest value available.
WARN–Value at limit reverse direction.	The entered value is beyond the upper or lower limit. Adjust to a value within the limits.
WARN–Value entered is illegal, re-enter.	The Model 268 will not accept the entered value. Enter an acceptable value (see relevant section in manual).
WARN–Value out of limits, altered by 268, re-check data.	The Model 268 could not store the entered value so it changed to the maximum allowable value. Check the new value.
WARNING–Analog output outside range points.	Process variable information is outside the 4-20 mA range points. Rerange the flowmeter.
WARNING–Control loop should be in manual.	Before sending the data that could affect the 4–20 mA output signal, set the loop to manual control. After it is set, press F4.
WARNING–Data transmission error.	Previous communication between Model 268 and the flowmeter was not successful. If this message appears repeatedly, check the loop for a source of noise that could corrupt the signal.
WARNING–Loop may be returned to auto.	After completing a communication that required the loop to be set in manual, you may.
WARNING–Match XMTR S/N to nameplate S/N.	Check to be sure that the entered flowmeter serial number is the same as that on the flowmeter nameplate.
WARNING–Not on line.	The key you have pressed is not applicable for off-line configuration tasks.
WARNING–Process has been aborted.	Indicates that the self-test has been aborted by pressing any key.
WARNING–PV out of range.	Process variable information of the flowmeter exceeds sensor limits. Check flow rate. If it is too high, correct the flow. If not, the sensor has a malfunction and needs to be replaced.
WARNING–Some of the changes were not saved in the XMTR mem.	Flowmeter did not receive all configuration changes. Note differences in configuration data and reconfigure the flowmeter accordingly.
WARNING–This address already being used.	Another transmitter is already using the entered multi-drop address. Enter a new address.
WARNING–This will erase work reg.	Data in the Working Register will be replaced with data from a another location.
WARNING–XMTR/268 not in communication.	Model 268 did not get answer from flowmeter: <ul style="list-style-type: none"> • Check connections. • Check that power is reaching flowmeter. • Check for minimum 250 ohms resistance in loop.
WARNING–XMTR in output mode.	During start-up and restart, the transmitter milliamp output does not reflect the process variable. Press F4.
WARNING–XMTR is not communicating.	Model 268 did not get answer from flowmeter: <ul style="list-style-type: none"> • Check connections. • Check that power is reaching flowmeter. • Check for minimum 250 ohms resistance in loop.
WARNING–268 does not know this XMTR.	Model 268 recognizes a Rosemount transmitter in the loop but cannot communicate with it. The message usually indicates a software revision level incompatibility between the Model 268 and the transmitter.
XMTR Mem diff than WORK Regs–XMTR not changed.	Data in the Working Register and in the flowmeter have different unique identifiers. The Model 268 was probably connected to different flowmeter without RESTART or power-off/power-on sequence. Press RESTART to erase the Working Register or save the Working Register to the Off-line Memory and download to the proper flowmeter at a later time.
XMTR Security: On–XMTR will not accept changes to memory.	Flowmeter lockout security switch is ON and electronics will not accept changes to configuration. Reset switch to remove this message.

Rosemount Model 8800C Vortex Flowmeter

Message	Description
XMTR still busy.	Flowmeter is running a computational or diagnostic routine and cannot respond to the Model 268 instructions. Press the PREVIOUS FUNCTION key to cancel.
XXXX=YYYY ERR—Illegal value.	Unacceptable value entered.
XXXX=YYYY ERR— Out of range.	The difference between LRV and URV is greater than the maximum span allowed by the flowmeter. Enter a new value.
XXXX=YYYY ERR—Span too small.	The difference between LRV and URV is less than the minimum span allowed by the flowmeter. Enter a new value.
XXXX=YYYY ERR—Value was too hi.	See instructions for the selected parameter. Enter a new value that is acceptable.
XXXX=YYYY ERR—Value was too lo.	See instructions for the selected parameter. Enter a new value that is acceptable.
XXXX=YYYY ERR—LRV too hi.	LRV was set to a value above the URL. Enter a new value.
XXXX=YYYY ERR—LRV too lo	LRV was set to a value above the LRL. Enter a new value.
XXXX=YYYY ERR— LRV and URV out limits.	Both the LRV and URV were outside the sensor's range limits. Enter a new value.
XXXX=YYYY ERR—URV too hi.	URV was set to a value above the URL. Enter a new value.
XXXX=YYYY ERR—URV too lo.	URV was set to a value below the LRL. Enter a new value.
XXXX=YYYY ERR—268 data err.	Flowmeter cannot interpret a Model 268 inquiry. Make note of conditions and keystrokes leading to failure, and contact Rosemount Service Center.
268 Failure—No. 1.	
268 Failure—No. 2.	Model 268 has detected bug in its software. Make note of conditions and keystrokes leading to failure, and contact Rosemount Service Center.
268 Test: FAIL.	Model 268 is not functioning properly. Turn OFF and contact Rosemount Service Center.

Electronics Verification

Safety Messages	page E-1
Electronics Verification	page E-2
Examples	page E-6

Electronics verification of the Model 8800C can be done by either utilizing the internal signal simulation capability or by applying an external signal source to the “TEST FREQ IN” and “GND” pins.

NOTE

It is not recommended to perform electronics verification while the process is running. If both operations are performed simultaneously, the effect of dual input frequencies may cause error in the electronics verification.

Using the Model 275 or AMS, the sensor can be disconnected from the electronics before you begin. The sensor may also be manually disconnected from the electronics as described in Install the Electronics Housing on page 4-15.

SAFETY MESSAGES

Instructions and procedures in this section may require special precautions to ensure the safety of the personnel performing the operations. Please refer to the following safety messages before performing any operation in this section.

WARNING

Explosions could result in death or serious injury:

- Do not remove the transmitter cover in explosive atmospheres when the circuit is alive.
- Before connecting a HART-based communicator in an explosive atmosphere, make sure the instruments in the loop are installed in accordance with intrinsically safe or non-incendive field wiring practices.
- Verify that the operating atmosphere of the transmitter is consistent with the appropriate hazardous locations certifications.
- Both transmitter covers must be fully engaged to meet explosion-proof requirements.

WARNING

Failure to follow these installation guidelines could result in death or serious injury:

- Make sure only qualified personnel perform the installation.

CAUTION

Remove power before removing the electronics housing.

ELECTRONICS VERIFICATION

Electronics functionality can be verified via two different verification methods:

- Flow Simulation Mode
- Using an External Frequency Generator

Both methods require the use of a HART-based Model 275 communicator or AMS. It is not required to disconnect the sensor to perform the electronics verification since the transmitter is capable of disconnecting the sensor signal at the input to the electronics. Should the user choose to physically disconnect the sensor from the electronics, refer to Replacing the Electronics Housing on page 4-13.

Electronics Verification Using Flow Simulation Mode

HART Comm.	1, 2, 4, 3, 1
------------	---------------

Electronics verification can be done by utilizing the internal flow simulation functionary. The Model 8800C is capable of simulating either a fixed flow rate or a varying flow rate. The amplitude of the simulated flow signal is based on the minimum required process density for the given line size and service type. Either type of simulation (fixed or varying) will effectively disconnect the Model 8800C sensor from the electronics charge amplifier input (see Figure 4-7) and replace it with the simulated flow signal. There is no need to select 2 “Sensor Offline.”

Fixed Flow Rate Simulation

HART Comm.	1, 2, 4, 3, 1, 1
------------	------------------

The fixed flow simulation signal can be entered in either percent of range or flow rate in the current engineering units. The resulting flow rate and/or shedding frequency can be continuously monitored via a Model 275 HART Communicator or AMS.

Varying Flow Rate Simulation

HART Comm.	1, 2, 4, 3, 1, 2
------------	------------------

The profile of the varying flow simulation signal is a repetitive triangular waveform as illustrated in Figure E-1. The minimum and maximum flowrate can be entered in either percent of range or entered as a flow rate in the current engineering units. The ramp time can be entered in seconds from a minimum of 0.533 seconds to a maximum of 34951 seconds. The resulting flow rate and/or shedding frequency can be continuously monitored via a Model 275 HART Communicator or AMS.

NOTE

To manually disconnect the sensor for precautionary measures, see Replacing the Electronics Housing on page 4-13 for details.

Figure E-1. Profile of Varying Flow Simulation Signal

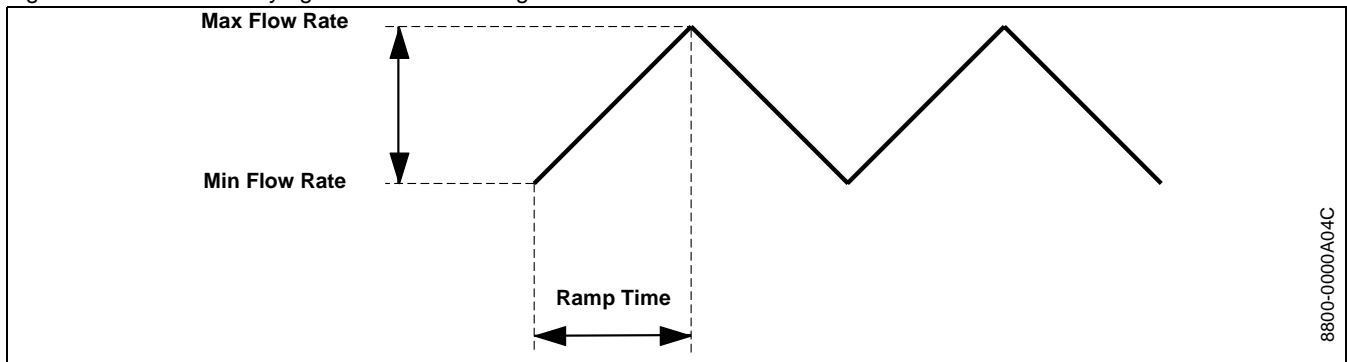

**Electronics Verification
Using an External
Frequency Generator**

If an external frequency source is desirable, then test points at the top of the electronics are available (see Figure E-2).

Tools Needed

- HART-based communicator; Model 275 or AMS
- Standard sinewave generator

1. Remove the electronics compartment cover.
2. Remove the two screws and the LCD indicator if applicable.
3. Connect a HART-based Model 275 Communicator or AMS to the loop.
4. Access the flow simulation menu on the communicator and select "Flow Sim External". This item is used with an External Frequency Generator. This will effectively disconnect the Model 8800C sensor input from the charge amplifier input of the electronics (see Figure 4-2). The simulated flow and/or the shedding frequency values will now be accessible via the Model 275 or AMS.
5. Connect the sinewave generator to the "TEST FREQ IN" and "GND" points as shown in Figure E-2.
6. Set the sinewave generator amplitude to $2V_{pp} \pm 10\%$.
7. Select the desired sinewave generator frequency.
8. Verify the generator frequency against the frequency displayed on the Model 275 or AMS.
9. Exit the Flow Simulation Mode.
10. Reconnect the LCD indicator option (if applicable) to the electronics board by replacing and tightening the two screws.
11. Replace and tighten the electronics compartment cover.

HART Comm.	1, 2, 4, 3, 2
------------	---------------

HART Comm.	1, 2, 4, 4
------------	------------

NOTE

To manually disconnect the sensor for precautionary measures, see Replacing the Electronics Housing on page 4-13 for details.

Figure E-2. Test Frequency Output and Chassis Ground Points

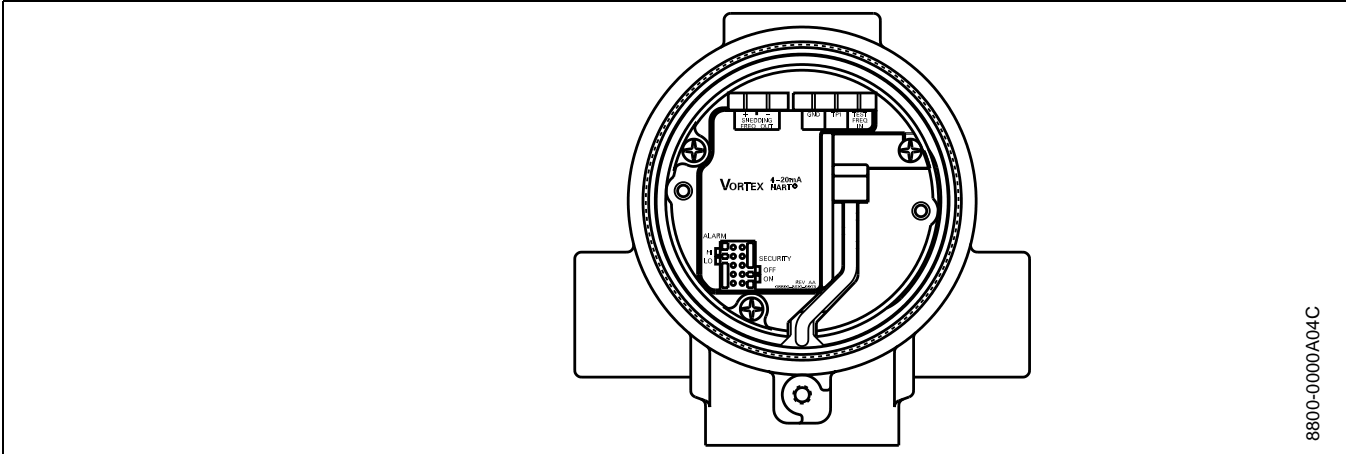

8800-0000A04C

Calculating Output Variables with Known Input Frequency

Use the following equations with a known input frequency for verification of a flow rate or 4–20 mA output within a given calibrated range. Select the proper equation depending on if you are verifying a flow rate, mass flow rate, 4–20 mA output, or special units. Example calculations starting on page E-6 may clarify how these equations are used.

To Verify a Flow Rate

For a given frequency F (Hz), and K-factor (compensated), find the flow rate Q :

$$Q = F(\text{Hz}) / (K \times C_x)$$

where C_x is the unit conversion (Table E-1).

To Verify a Standard or Normal Flow Rate

$$Q = F(\text{Hz}) \times ((\text{DensityRatio}) / (K \times C_x))$$

To Verify a Mass Flow Rate

For a given mass frequency F (Hz), and K-factor (compensated), find the mass flow rate M :

$$M = \frac{F}{(K/\rho) \cdot C}$$

where C is the unit conversion and ρ is density at operating conditions:

$$M = F(\text{Hz}) / (K C_x)$$

where C_x is the unit conversion using density (ρ) (Table E-1).

To Verify a 4–20 mA Output

For a given input frequency F (Hz), and K-factor (compensated), find output current I :

$$I = \left(\left[\frac{(F(\text{Hz}) / K \times C_x) - \text{LRV}}{\text{URV} - \text{LRV}} \right] (16) \right) + 4$$

where C_x is the unit conversion (Table E-1), URV is the upper range value (user units), and LRV is the lower range value (user units).

To Verify a Special Units Output

For special units, first divide the special unit-conversion factor into the base unit factor C_x .

$$C_{20} = C_x / \text{sp. units conv. factor (Table E-1)}$$

Unit Conversion Table (User Units to GPS)

Use the following table to assist with calculated frequencies when using user defined units.

Table E-1. Unit Conversions

C_x	Units (act)	Conversion Factor
C ₁	gal/s	1.00000E+00
C ₂	gal/m	1.66667E-02
C ₃	gal/h	2.77778E-04
C ₄	Impgal/s	1.20095E+00
C ₅	Impgal/m	2.00158E-02
C ₆	Impgal/h	3.33597E-04
C ₇	L/s	2.64172E-01
C ₈	L/m	4.40287E-03
C ₉	L/h	7.33811E-05
C ₁₀	CuMtr/m	4.40287E-00
C ₁₁	CuMtr/h	7.33811E-02
C ₁₂	CuFt/m	1.24675E-01
C ₁₃	CuFt/h	2.07792E-03
C ₁₄	bbl/h	1.16667E-02
C ₁₅	kg/s	C ₁₀ *60/ρ
C ₁₆	kg/h	C ₁₁ /ρ
C ₁₇	lb/h	C ₁₃ /ρ
C ₁₈	shTon/h	C ₁₇ ×2000
C ₁₉	mTon/h	C ₁₆ ×1000
C ₂₀	SPECIAL	C _x /special units conversion factor*

ρ=operating density

* Special units conversion factor

EXAMPLES

The following examples illustrate the calculations that may be necessary for your application. The first set of three examples is in English units. The second set of three examples is in SI units.

English Units

Example 1 (English units)

Fluid =	Water	URV=	500 gpm
Line size =	3 in.	LRV=	0 gpm
Line press.=	100 psig	C ₂ =	1.66667E-02 (from Table D-2 on page D-4)

Temp op. = 75 °F
 K-factor
 (compensated) = 10.79 (via HART communicator or AMS)
 $Q = F(\text{Hz}) / (K \times C_2)$
 $= 75.00 / (10.79 \times 0.0166667)$
 $= 417.1 \text{ gpm}$

Therefore, an input frequency of 75.00 Hz represents a flow rate of 417.1 gpm in this application.

For a given input frequency, you may also determine the current output. Use the above example with an input frequency of 75.00 Hz:

URV= 500 gpm LRV= 0 gpm $F_{in}(\text{Hz}) = 75.00$

$$I = \left(\left[\frac{F(\text{Hz}) / (K \times C_2) - \text{LRV}}{\text{URV} - \text{LRV}} \right] \times (16) \right) + 4$$

$$= \left(\left[\frac{75.00 / (10.79 \times 0.0166667) - 0}{500 - 0} \right] \times (16) \right) + 4$$

$$= 17.34 \text{ mA}$$

Therefore, an input frequency of 75.00 Hz represents a current output of 17.34 mA.

Example 2 (English units)

Fluid = Saturated Steam URV = 40000 lb/hr

Line size = 3 in. LRV= 0 lb/hr

Line press. = 500 psia $C_{17} = C_{13}/\rho$ (Table D-2 on page D-4)

Temp op. = 467 °F Density (ρ) = 1.078 lb/cu-ft

Viscosity = 0.017 cp

K-factor (compensated) = 10.678 (via HART communicator or AMS)

$$M = F(\text{Hz}) / (K \times C_{17})$$

$$= 400 / \{10.678 \times (C_{13}/\rho)\}$$

$$= 400 / \{10.678 \times (0.00207792/1.078)\}$$

$$= 400 / (10.678 \times 0.0019276)$$

$$= 19271.2 \text{ lb/hr}$$

Therefore, an input frequency of 400 Hz represents a flow rate of 19271.2 lb/hr in this application.

For a given input frequency, you may also determine the current output. Use the example on page D-9 with an input frequency of 300 Hz:

URV= 40000 lb/hr LRV= 0 lb/hr $F_{in}(\text{Hz}) = 300.00$

$$I = \left(\left[\frac{F(\text{Hz}) / (K \times C_{17}) - \text{LRV}}{\text{URV} - \text{LRV}} \right] \times (16) \right) + 4$$

$$= \left(\left[\frac{300 / (10.678 \times 0.0019276) - 0}{40000 - 0} \right] \times (16) \right) + 4$$

$$= 9.83 \text{ mA}$$

Therefore, an input frequency of 300.00 Hz represents a current output of 9.83 mA.

Example 3 (English units)

Fluid = Natural gas URV = 5833 SCFM

Line size = 3 in. LRV = 0 SCFM

Line press. = 140 psig $C_{20} = C_x/\text{sp. units factor}$ (from Table D-4 on page D-5)

Temp op. = 50 °F Density (ρ) = 0.549 lb/cu-ft (oper)

Viscosity = 0.01 cp

K-factor(compensated) = 10.797 (via HART communicator or AMS)

$$= 700 / \{10.797 \times (0.124675 / 10.71)\}$$

$$= 5569.4 \text{ SCFM}$$

Therefore, an input frequency of 700.00 Hz represents a flow rate of 5569.4 SCFM in this application.

For a given input frequency, you may also determine the current output. Use the above example with an input frequency of 200 Hz.

URV = 5833 SCFM LRV = 0 SCFM $F_{in} \text{ (Hz)} = 200.00$

$$I = \left(\left[\frac{F(\text{Hz}) / (K \times C_{20}) - \text{LRV}}{\text{URV} - \text{LRV}} \right] \times (16) \right) + 4$$

$$\left(\left[\frac{200 / (10.797 \times 0.011641) - 0}{5833 - 0} \right] \times (16) \right) + 4$$

$$= 8.36 \text{ mA}$$

Therefore, an input frequency of 200.00 represents a current output of 8.36 mA.

SI Units

Example 1 (SI units)

Fluid = Water URV= 2000 lpm

Line size = 80 mm LRV= 0 lpm

Line press. = 700 kPag $C_8 = 4.40287E-03$ (from Table D-4 on page D-5)

Temp op. = 60 °C

K-factor (compensated) = 10.772 (via HART communicator or AMS)

$$Q = F \text{ (Hz)} / (K \times C_8)$$

$$= 80 / (10.772 \times 0.00440287)$$

$$= 1686.8 \text{ lpm}$$

Therefore, an input frequency of 80.00 Hz represents a flow rate of 1686.8 lpm in this application.

For a given input frequency, you may also determine the current output. Use the above example with an input frequency of 80.00 Hz:

URV= 2000 lpm LRV= 0 lpm $F_{in} \text{ (Hz)} = 80.00$

$$I = \left(\left[\frac{F(\text{Hz}) / (K \times C_8) - \text{LRV}}{\text{URV} - \text{LRV}} \right] \times (16) \right) + 4$$

$$= \left(\left[\frac{80 / (10.772 \times 0.00440287) - 0}{2000 - 0} \right] \times (16) \right) + 4$$

$$= 17.49 \text{ mA}$$

Therefore, an input frequency of 80.00 Hz represents a current output of 17.49 mA.

Example 2 (SI units)

Fluid = Saturated Steam URV = 3600 kg/hr

Line size = 80 mm LRV= 0 kg/hr

Line press.= 700 kPag $C_{16} = C_{11}/\rho$ (from Table D-4 on page D-4)

Temp op. = 170 °C Density(ρ) = 4.169 kg/cu-mtr (oper)

Viscosity = 0.015 cp

K-factor (compensated) = 10.715 (via HART communicator or AMS)

$$M = F(\text{Hz}) / (K \times C_{16})$$

$$= 650 / \{10.715 \times (C_{11}/\rho)\}$$

$$= 650 / \{10.715 \times (0.0733811/4.169)\}$$

$$= 650 / (10.715 \times 0.017602)$$

$$= 3446.4 \text{ kg/hr}$$

Therefore, an input frequency of 650.00 Hz represents a flow rate of 3446.4 kg/hr in this application.

For a given input frequency, you may also determine the current output. Use the prior example with an input frequency of 275 Hz:

URV= 3600 kg/hr LRV= 0 kg/hr $F_{in}(Hz) = 275$

$$I = \left(\left[\frac{F(Hz) / K \times C_{16} - LRV}{URV - LRV} \right] \times (16) \right) + 4$$

$$= \left(\left[\frac{275 / (10.715 \times 0.017602) - 0}{3600 - 0} \right] \times (16) \right) + 4$$

$$= 10.48 \text{ mA}$$

Therefore, an input frequency of 275.00 Hz represents an output current of 10.48 mA.

Example 3 (SI units)

Fluid = Natural Gas URV = 10,000 NCMH

Line size = 80 mm LRV= 0 NCMH

Line press. = 1000 kPaG $C_{20} = C_x/sp.$ units factor (from Table E-1)

Temp op. = 10 °C Density(ρ) = 9.07754 kg/cu-mtr (oper)

Viscosity = 0.01 cp

K-factor(compensated) = 10.797 (via HART communicator or AMS)

$$= 700 / \{10.797 \times (.0733811 / 10.48)\}$$

$$= 9259.2 \text{ NCMH}$$

Therefore, an input frequency of 700.00 Hz represents a flow rate of 9259.2 NCMH in this application.

For a given input frequency, you may also determine the current output. Use the above example at the 8.0 mA point:

URV= 10000 NCMH LRV= 0 NCMH $F_{in}(Hz) = 375.00$

$$I = \left(\left[\frac{F(Hz) / (K \times C_{20}) - LRV}{URV - LRV} \right] \times (16) \right) + 4$$

$$= \left(\left[\frac{375 / (10.797 \times 0.0070020) - 0}{10000 - 0} \right] \times (16) \right) + 4$$

$$= 11.94 \text{ mA}$$

Therefore, an input frequency of 375.00 Hz represents a current output of 11.94 mA.

Rosemount Inc.

8200 Market Boulevard
Chanhassen, MN 55317
USA

Tel 1-800-999-9307
Fax (952) 949-7001
© 2000 Rosemount, Inc.

Fisher-Rosemount Flow

Groeneveldselaan 6-8
3903 AZ Veenendaal
The Netherlands

Tel 31 (0) 318 549 549
Fax 31 (0) 318 549 559
Tel 0800-966-180 (U.K. only)
Fax 0800-966-181 (U.K. only)

Fisher-Rosemount

Singapore Pte Ltd.
1 Pandan Crescent
Singapore 128461

Tel (65) 777-8211
Fax (65) 777-0947
AP.RMT-Specialist@frco.com



00809-0100-4003, Rev. JA, 4/01



ROSEMOUNT®

Product documentation available at...
www.rosemount.com

