

INSTRUCTION MANUAL

FOR

MODEL 365A & E365A

VIBRASWITCH® MALFUNCTION DETECTOR



Robertshaw Industrial Products
1506 Mustang Drive
Maryville, Tennessee 37801
Phone: (865) 981-3100 Fax: (865) 981-3168

INSTRUCTION MANUAL NUMBER

909GF294G

TABLE OF CONTENTS

SECTION		PAGE
1	DESCRIPTION	1
	1.1 General	1
	1.2 Model Identification	1
2	SPECIFICATIONS	2
	2.1 Environmental	2
	2.2 Electrical	2
	2.3 Performance	2
	2.4 Enclosure	2
	2.5 Agency Certification	2
3	INSTALLATION	3
	3.1 General	3
	3.2 Mounting	3
	3.3 Space Heater	3
	3.4 Wiring	6
4	OPERATION	9
	4.1 Operation	9
	4.2 Adjustment of Operating Setpoint	9
5	MAINTENANCE	12
	5.1 Trouble Shooting	12
	5.2 Replacement (Spare) Parts	13
	5.3 Repairs	13
	5.4 Routine Maintenance	14

ILLUSTRATIONS

FIGURE		PAGE
3-1	Methods of Mounting the Vibraswitch	4
3-2	Dimensions	5
3-3	External Wiring Connections	6
3-4	Terminal Configurations	7
3-5	Preparation of Conduit Wiring	8
3-6	Connection of Conduit Wiring	8
4-1	Operating Principal for the Vibraswitch	9
4-2	Setpoint Adjustment	10
4-3	Setpoint Alarm Settings	11

Section 1 – DESCRIPTION

1.1 GENERAL

The Model 365A and E365A Vibraswitches provide maximum protection for large motors, pumps, compressors, and other rotating equipment by responding to mechanical malfunctions the instant they occur. Failing bearings, bent shafts, broken blades, overspeeding and similar malfunctions cause increased imbalance or high frequency vibration detectable with the Model 365A and E365A Vibraswitches. The instruments may be wired to actuate an alarm or cause a shutdown before costly damage occurs. They are designed for maintenance-free service in permanent installations.

The Vibraswitches are acceleration sensitive instruments. Acceleratory measurements made by the Vibraswitches are the summation of all the individual accelerations giving a total destructive force acting on the machine - the result is positive protection.

Vibraswitches may be supplied with or without a reset coil. Reset coils may be used with external time delays for preventing false trips on those machines with excessive start-up vibration by applying the rated voltage during machine start-up (for 4 minutes maximum). Reset coils may also be used to reset the Vibraswitch from a remote location by applying the rated voltage.

Space heaters are intended to prevent condensation in the enclosure caused by climate conditions in some outdoor installations. Space heaters require constant power and are not required in most applications.

With the growing use of computers, an increasing number of applications are coming into existence where a Vibraswitch will be connected to a computer or PLC. In these applications the voltage and/or current may be too low for standard contacts. For these applications the Model 365A and E365A may be supplied with an optional sealed switch with gold contacts.

The Vibraswitch may be used in conjunction with the Model 563A Monitor This Monitor is designed to “sort-out” false signals received by the Vibraswitch so that Alarm and/or Shutdown will not result from false transient disturbances.

1.2 MODEL IDENTIFICATION

Identify Vibraswitch models in accordance with the descriptions and variations listed in each table.

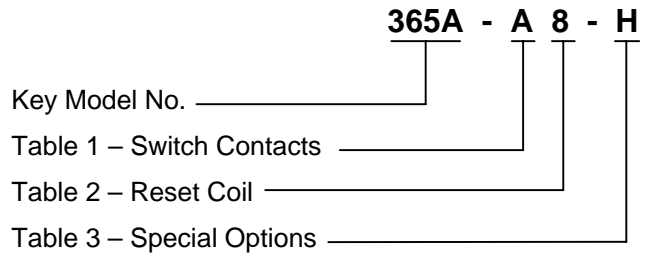

KEY MODEL NO.	
Model No.	Description
365A	Vibraswitch, UL Certified for the U.S.A. & c-UL Certified for Canada.
E365A	Vibraswitch, CE (ATEX) Certified for Europe, UL Certified for the U.S.A. & c-UL Certified for Canada.

Desig.	Description
A	SPDT – Single pole, double throw load contacts.
D	DPDT – 2 gang mounted SPDT load switches.
G	DPDT – 2 gang mounted SPDT sealed switches with gold contacts for low voltage/current applications.

Desig.	Description
0	No reset coil
2	24 volt DC reset coil
3*	240 volt AC reset coil.
4	48 volt DC reset coil
7	117 volt DC reset coil
8	120 volt AC reset coil

* Not Agency Certified. Not available with model E365A.

Desig.	Description
Omit	No special options. Enclosure 4 & IP66, unpainted aluminum.
E	Enclosure 4X & IP66, exterior painted with gray epoxy enamel.
H	Space heater installed for maintaining internal area of enclosure moisture free.
EH	Enclosure 4X & IP66, exterior painted with gray epoxy enamel, and space heater installed for maintaining internal area of enclosure moisture free.

Section 2 - SPECIFICATIONS

2.1 ENVIRONMENTAL

Ambient Temperature Limits:

-13° F to +140° F (-25° C to +60° C)

Shock 40 G @11 ms maximum

Net weight 7 lbs (3.2 kg)

Shipping weight 8 lbs (3.6 kg)

2.2 ELECTRICAL

Contact Arrangement SPDT or DPDT

Contact Rating:

Designation "A":

SPDT

7 A max, 460 VAC max, 50/60 Hz, NI;

0.5 A max, 120 VDC max, NI;

1 A max, 48 VDC max, NI;

2 A max, 24 VDC max, NI;

5 A max, 12 VDC max, NI

Designation "D":

DPDT

5 A max, 240 VAC max, 50/60 Hz, NI;

5 A max, 30 VDC max, NI

Designation "G":

DPDT – Sealed switch, gold contacts

0.1 A max, 125-250 VAC, NI;

0.1 A max, 30 VDC, NI;

5 mA min at 6 VDC, NI;

2 mA min at 12 VDC, NI;

1 mA min at 24 VDC, NI

Reset Coil Voltages & Power:

24 VDC ± 10%, 0.5 amp

48 VDC ± 10%, 0.2 amp

117 VDC ± 10%, 0.14 amp

120 VAC ± 10%, 50/60 Hz, 0.3 amp

240 VAC ± 10%, 50/60 Hz, 0.3 amp

Reset Coil Duty Cycle 4 minutes **ON** max.
10 minutes **OFF** min.

Space Heater 2 watt, same voltage
as reset coil

2.3 PERFORMANCE

Set Point Range:

Mounted Horizontal 0 to 4.5 G (peak)

Mounted Vertical 0 to 3.5 G (peak)

Frequency Range 0 to 300 Hz
(0 to 18,000 RPM)

Set Point Adjustment 1 G per turn
(approximate)

Manual Reset Included on all models

2.4 ENCLOSURE

Enclosure Aluminum, unpainted (standard)
Aluminum, epoxy painted (optional)

Enclosure seals Silicone

Enclosure Hardware Stainless steel

Enclosure Rating:

Model 365A:

Class I, Div. 1, Group B, C & D;

Class II, Div. 1, Group E, F & G;

Enclosure 4 or 4X:

Class I, Zone 1, AEx d IIB+H T6;

Ex d IIB+H T6; IP66

Model E365A:

Class I, Div. 1, Group B, C & D;

Class II, Div. 1, Group E, F & G;

Enclosure 4 or 4X:

Class I, Zone 1, AEx d IIB+H2 T6;

Ex d IIB+H2 T6; IP66;

ATEX EEx d IIB+H2 T6 IP66

2.5 AGENCY CERTIFICATIONS

UL File No. E164999

c-UL File No. E164999

CE (ATEX) Certificate No.

DEMKO 05 ATEX 0436069

CE PRODUCT CERTIFICATION

Vibraswitch models with CE (ATEX) Approval are distinguished by the addition of the CE mark on the nameplate. The nameplate includes additional information:

Manufacturer's name and address:

Robertshaw Industrial Products

1602 Mustang Drive

Maryville, TN 37801

The manufacturer's Model Number:

E365A

Serial number:

Unique serial number assigned by manufacturer

which includes a code for year of construction.

Marking according to Group II: IIB+H

Marking essential for safe use: T6

Enclosure Rating: IP66

Certificate number:

DEMKO 05 ATEX 0436069

Essential information for safe use:

1. The equipment temperature code is T6.

2. The ambient temperature range for the equipment is -13° F (-25° C) to +140° F (+60° C).

3. The equipment must be bolted closed before power is applied.

4. All cable entry devices and blanking elements shall be certified in type of explosion protection flameproof enclosure "d", suitable for the conditions of use and correctly installed.

5.Unused apertures shall be closed with suitable blanking elements.

Section 3 - INSTALLATION

3.1 GENERAL

Examine the Vibraswitch for possible shipping damages. **IMPORTANT:** If for any reason it is determined that the Vibraswitch should be returned to the factory, please notify the nearest Robertshaw sales representative prior to shipment. Each Vibraswitch must be properly packaged to prevent damage. Robertshaw assumes no responsibility for equipment damaged in shipment due to improper packaging.

Choose the location in accordance with good instrument practice, avoiding extremes of temperature, humidity and vibration (see SECTION 2 – SPECIFICATIONS).

The Model 365A and E365A Vibraswitches are certified for use in hazardous areas as indicated in SECTION 2 – SPECIFICATIONS. In locations where moisture condensation within explosion-proof junction boxes is a problem a two-watt resistor (space heater) may be placed across terminals 6 and 7 inside the Vibraswitch cover and wired to provide continuous heat and circulation of air. (See Table 3-1 for resistance values.)

3.2 MOUNTING

Figure 3-1 illustrates the methods of mounting on various pieces of equipment. Figure 3-2 shows the mounting dimensions and Figures 3-3 and 3-4 show the external wiring for the Vibraswitch.

The vibration sensitive axis of the Vibraswitch is perpendicular to its mounting base. Therefore, the Vibraswitch must be mounted on a plane that will detect the vibratory motion for which protection is desired. The Vibraswitch may be mounted at any location along the length of machines containing rotating shafts that are horizontal and parallel to the base of the machine; the preferable location being in line with the rotating shaft (ref. Figure 3-1). Do not mount the Vibraswitch perpendicular to the ends of rotating shafts unless the end play or end-thrust measurement is desired. Normally, bent shafts worn bearings and other anomalies are detected near the bearing housings and at right angles to the shaft.

The Vibraswitch may be mounted in any position between the side (vertical) or the top (horizontal) of bearings or machine housings. It should be noted that when mounting Vibraswitches on top (horizontal position) of equipment the vibration range is as stated

in the SPECIFICATION SECTION. However, when the Vibraswitch is mounted on a side position (90° from the horizontal), 1 g is subtracted from the measurement range.

If a custom mounting bracket is used to mount the Vibraswitch due to an irregular mounting surface, it must be constructed of steel having sufficient thickness and properly reinforced so that mechanical resonances are not introduced; usually 1/2" (12.7 mm) steel plate is satisfactory if the dimensions of the bracket are minimal (ref. Figure 3-1). It is extremely important that all four corners of the Vibraswitch, as well as the mounting bracket, be rigidly secured to the machine. Exact location is not critical as the adjustment procedure of the Vibraswitch automatically accounts for the normal vibration at that location.

The Vibraswitch, when properly adjusted, trips on a relative increase in vibration.

When installing the Vibraswitch on existing equipment where several convenient mounting positions are available, it is advisable to check the existing vibration level at each possible position before permanently mounting the Vibraswitch. The Vibraswitch can be used to measure existing vibration by holding or clamping it against the running machine and determining the trip point as described under "ADJUSTMENT" in this manual. Should normal vibration exceed the range of the Vibraswitch, it is recommended that consideration be given to a Robertshaw Velocity-Acceleration Monitor Model 566.

When mounting on a hot surface, metal spacers may be placed at all four mounting holes to elevate the Vibraswitch to allow for additional air flow between the hot surface and the Vibraswitch. Spacers should be 3/4" (19 mm) diameter minimum and 3/4" (19 mm) high maximum.

3.3 SPACE HEATER

In some outdoor installations, it may be necessary to install a space heater (resistor) to prevent moisture condensation. A small conventional carbon 2 watt resistor should be installed across terminals 6 and 7 in the Vibraswitch. Proper resistor values are shown in Table 3-1.

Table 3-1
Space Heater Resistance Values

VOLTAGE (AC OR DC)	SPACE HEATER RESISTOR (OHMS)
460	0.22 meg
240	56,000
120	12,000
48	2,200
24	620

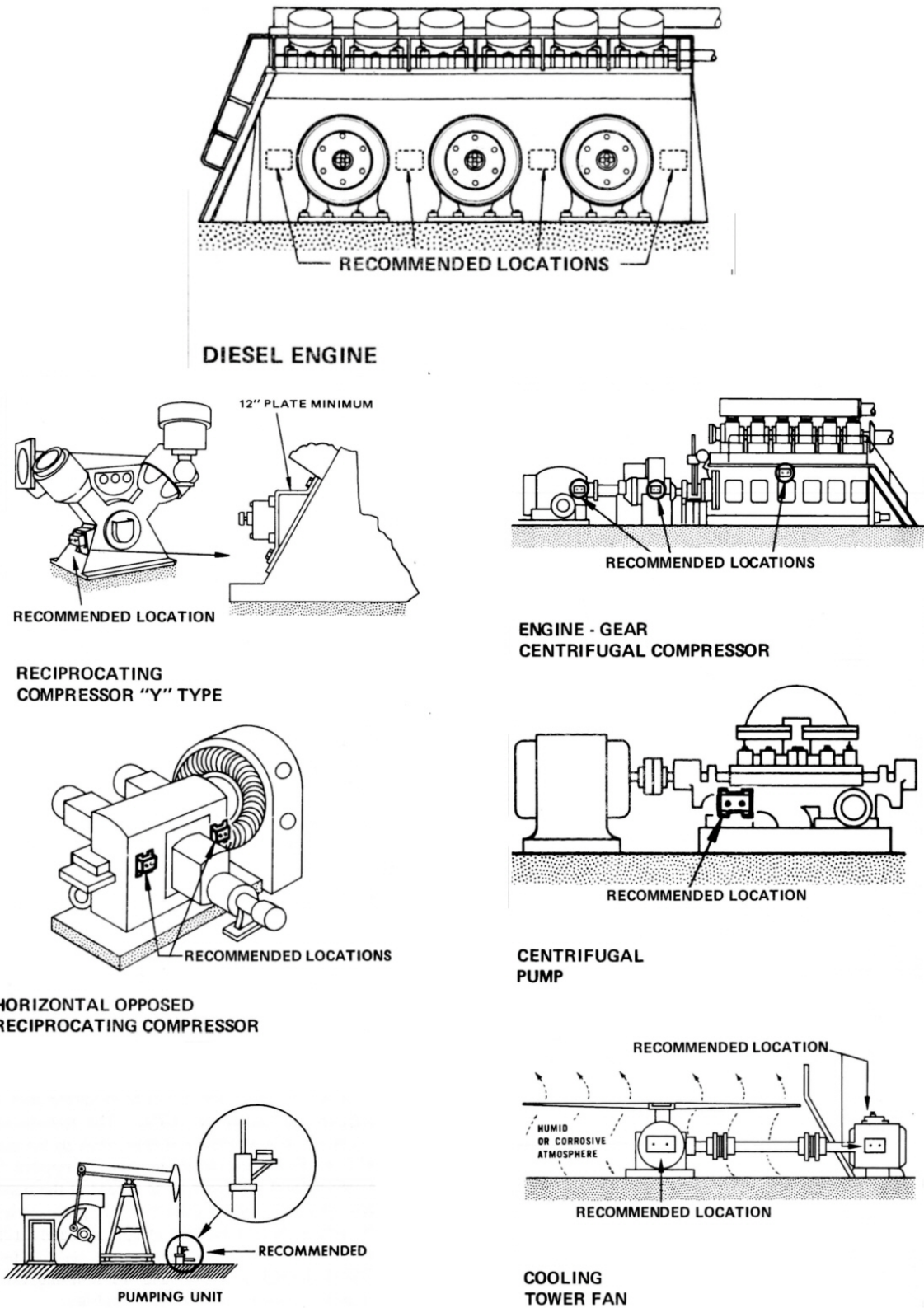

Figure 3-1
Methods of Mounting the Vibraswitch

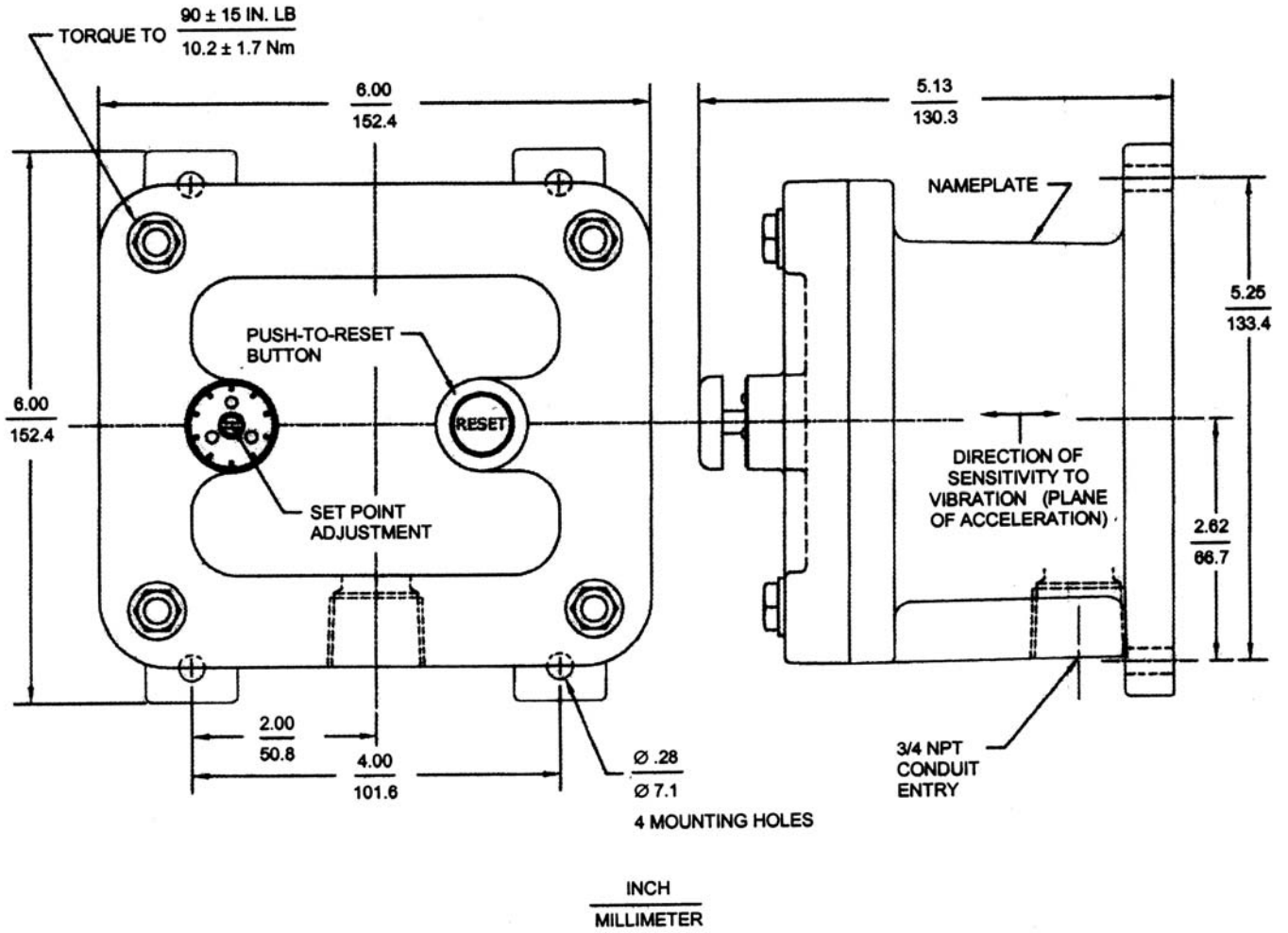

Figure 3-2
Dimensions

3.4 WIRING

The Vibraswitch is equipped with a threaded hub for 3/4" conduit. When the vibration amplitude is large (i.e., greater than 5 mils) it is good practice to use a short length of flexible conduit to serve as an isolator between the rigid conduit and the Vibraswitch. Wiring into the unit should be done with #18 stranded wire, although #14 can be used where necessary. The Vibraswitch was not designed for wiring with heavy, solid wire. However, where necessary to use a heavier wire, as in low voltage DC applications, a junction box near the Vibraswitch should be used.

For Vibraswitches with gold plated contacts (Model 365A-G and E365A-G) it is recommended to connect the two poles in parallel when only one pole is required (SPST or SPDT operation) as specified in Table 3-2.

Table 3-2
Jumpers for SPST or SPDT Operation
with Gold Contacts

CONNECT TERMINALS
3 to 8 (NO)
4 to 9 (C)
5 to 10 (NC)

NOTE

All instrument installation wiring must be done in accordance with local codes and commonly accepted practices.

NOTE

Conduit runs must have a sealing fitting connected within 18 inches (46 cm) of the enclosure to prevent infiltration of moisture-laden air or corrosive gasses into the enclosure.

NOTE

All cable entry devices and blanking elements shall be certified in type of explosion protection flameproof enclosure "d", suitable for the conditions of use and correctly installed.

NOTE

Unused apertures shall be closed with suitable blanking elements.

When wiring the Vibraswitch refer to Figures 3-3, 3-4, 3-5, 3-6 and all instructions associated with those figures.

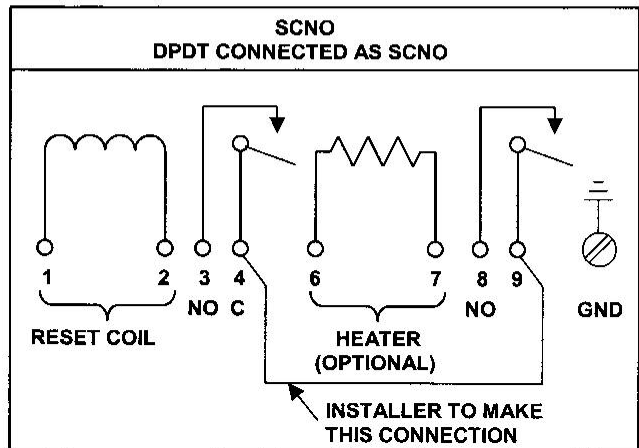
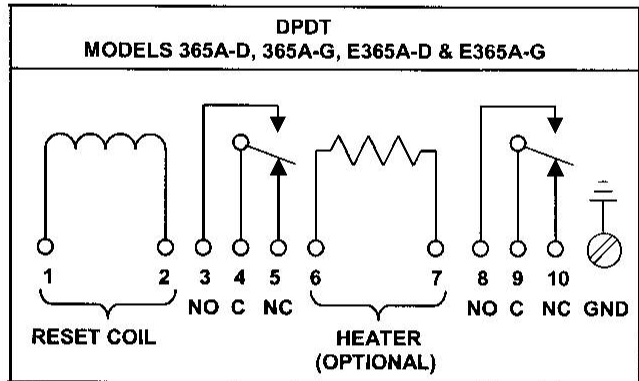
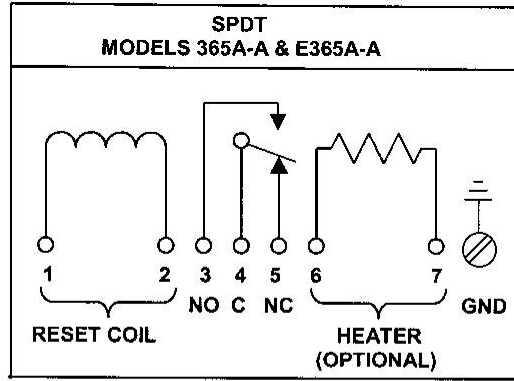
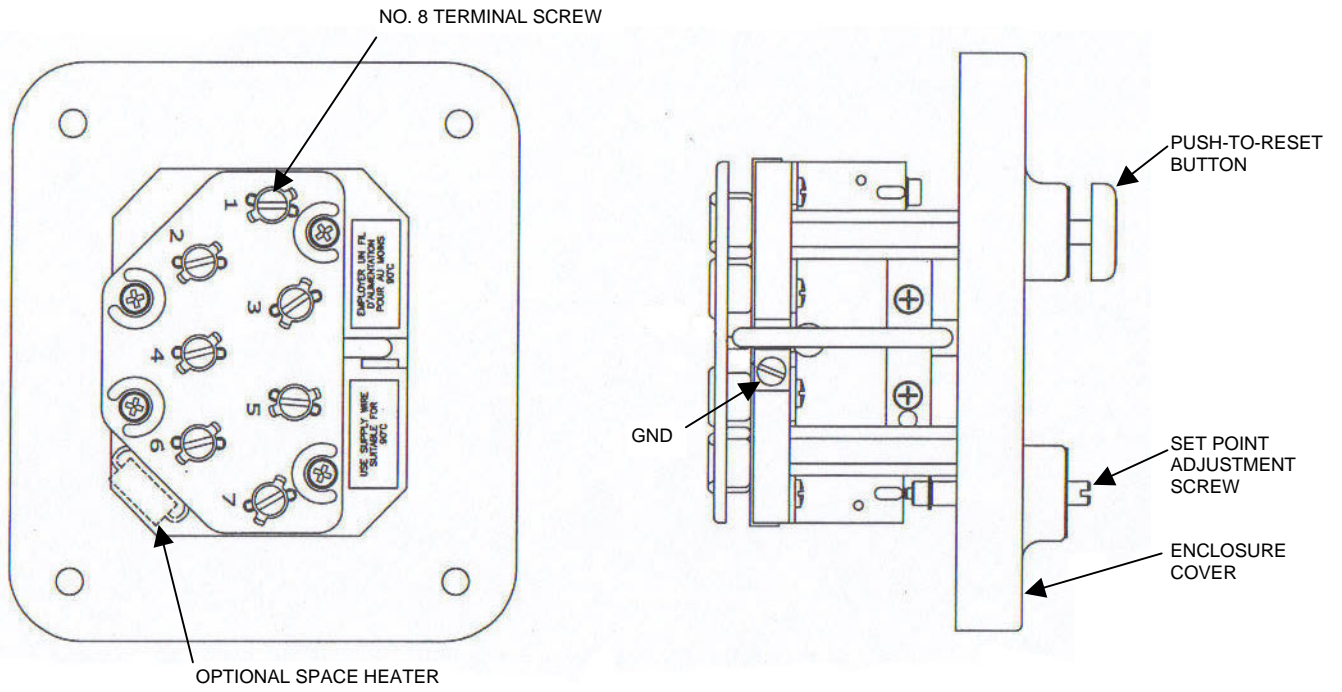

Figure 3-3

External Wiring Connections

1. Switch shown in normal (reset) position. Reverses on actuation from increased vibration.
2. If only a Manual Reset is desired, do not make connections to terminals 1 and 2.
3. Heater resistor supplied only when specified.



365A-A and E365A-A

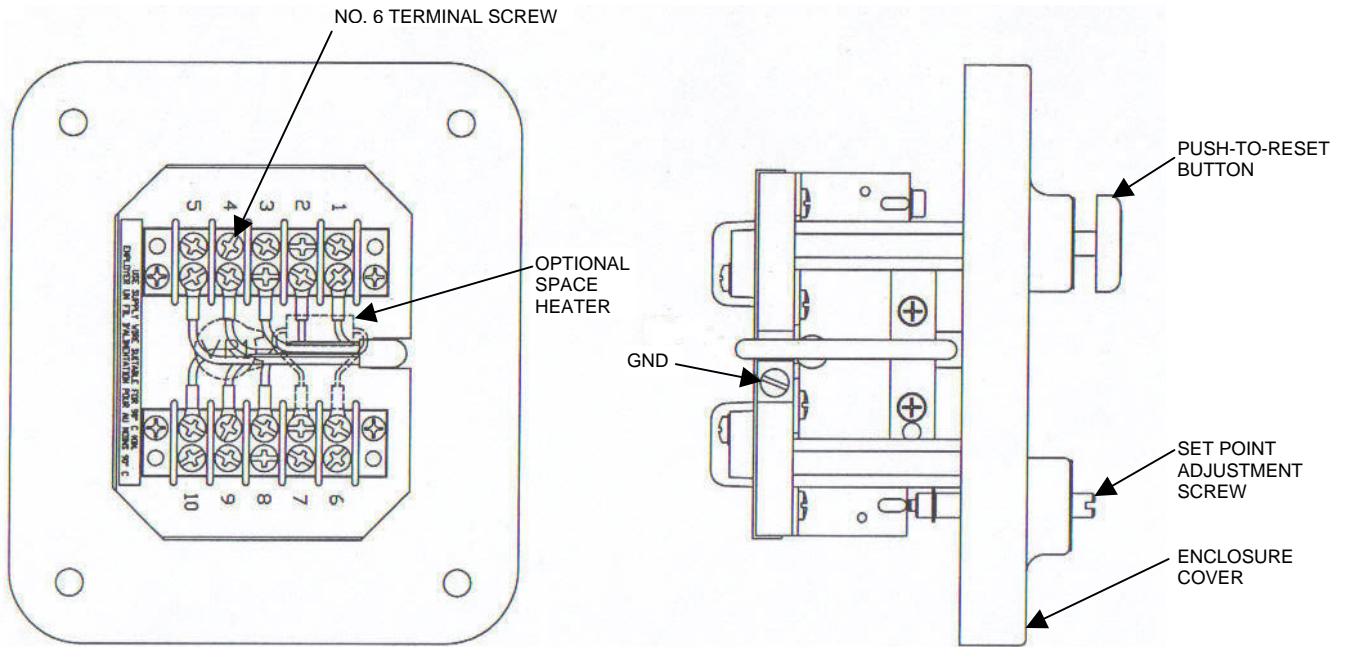

365A-D, 365A-G, E365A-D and E365A-G

Figure 3-4
Terminal Configurations

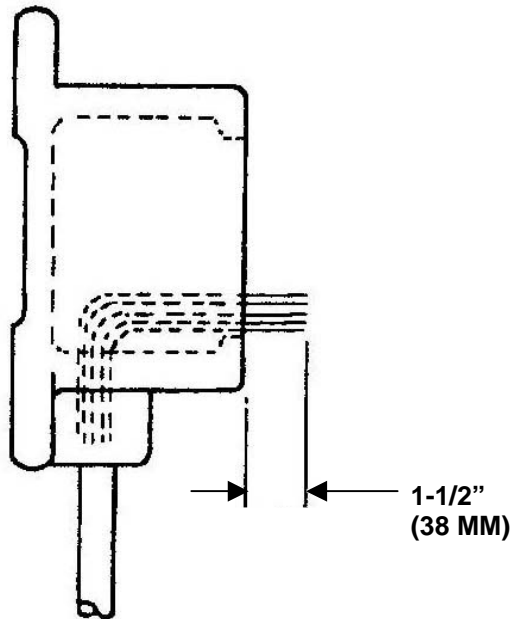

Figure 3-5
Preparation of Conduit Wiring

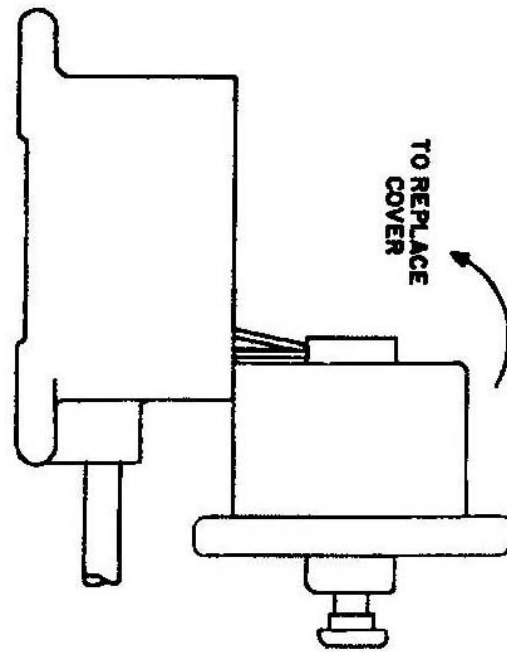

Figure 3-6
Connection of Conduit Wiring

To avoid unnecessary difficulty in wiring the Vibraswitch, the following procedure should be used:

- a. When threading conduit, cut the wires so that all wires project beyond the housing surface approximately 1-1/2" (38 mm) as shown in Figure 3-5. Do not later pull the wires tight as you will be unable to remove cover holding the mechanism.
- b. Strip wires back 1/4" (6.4 mm) and install solderless terminals.
- c. Place the Vibraswitch in position shown in Figure 3-6 and connect wires to corresponding terminals.
- d. Flatten wires entering housing against wall on conduit hub side and rotate cover into place, pushing extra wire into corners near conduit hub.
- e. Replace cover bolts, tighten to 75-105 inch lbs (8.5-11.9 Nm).

Section 4 - OPERATION

4.1 OPERATION

The Vibraswitch (ref. Figure 4-1), is sensitive to vibration in a direction (the sensitive axis) perpendicular to its mounting base. It contains a vibration detecting mechanism, which also functions as a “mechanical amplifier”, to activate a snap-action switch when the selected level of vibration is exceeded and the detecting mechanism “trips”.

The detecting mechanism consists of an armature suspended on a flexure pivot that is restrained from motion by a permanent magnet (the holddown magnet). In the “armed” condition, the armature is held against the stop pin by the holddown magnet. The stop-pin maintains a precise air gap between the armature and the holddown magnet. On the opposite end of the armature, the compression spring provides an adjustable force to oppose the force of the holddown magnet. Whenever the peak vibration inertial force (mass x acceleration) plus the adjustable compression spring force exceeds the force of the holddown magnet, the armature is released and is pulled into the latching magnet (“tripped position”). Simultaneously, it activates the snap-action switch. This detecting mechanism has a uniform response from 0 to 300 Hz over a range of 0 to 4.5 g’s.

The mechanism may be reset to the “armed” position manually (locally) or electrically (remotely). Manually, depress the reset button to move the armature away from the latching magnet (“tripped” position) until it is held against the stop pin (“armed” position). Electrically, the reset coil may be energized to pull the armature into the “armed” position against the stop pin.

A reset and holding coil is provided, in the DC/AC voltage as specified, so that accidental shutdowns on starts can be prevented. External time-delay relay circuits are required to maintain voltage at the holding coil during startup period and then release this voltage when operation is normal. At full voltage the reset coil should not be energized for more than four minutes to prevent overheating. Then, the reset coil must be de-energized for a period of ten minutes before re-energizing. For longer hold-in requirements the reset coil should be energized at full voltage and then held-in at one-half the rated voltage.

The Vibraswitch may be used in conjunction with the Vibraswitch Monitor, Model 563A. This monitor is a solid-state electronic system designed to “sort-out” false signals received by the Vibraswitch so that Alarm and/or Shutdown of the operating machine will not result from false, transient disturbances. Examples of transient disturbances are the closing of pipeline check valves on pumping applications, the start-up of

additional pumps on a line, and the initial start-up of various operating machines. These disturbances may cause the Vibraswitch to “trip-out” if the vibratory shock level is in excess of its setpoint.

The purpose of the Vibraswitch Monitor is to “supervise” and “sort-out” the transient disturbances so that Alarm or Shutdown is not falsely imposed on the machine being monitored, but any continuous vibration level which exceeds the Setpoint of the Vibraswitch will cause Alarm and/or Shutdown.

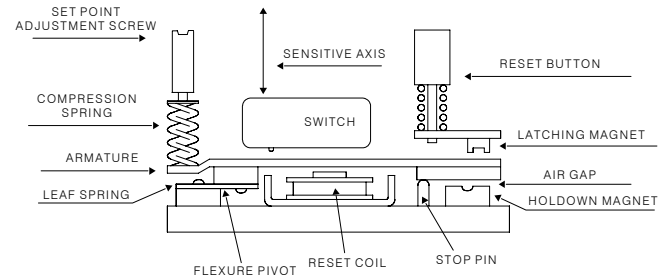

Figure 4-1
Operating Principal for the Vibraswitch

4.2 ADJUSTMENTS OF SETPOINT

The operating setpoint for the Vibraswitch varies with the type of machine and its location (measurement point) on the machine. The setpoint adjustments suggested in this manual are for machines which are functioning in a “good” or “normal” condition. This method follows the concept of vibration tolerance for the machine and in this case is dependent upon an individual who is experienced in the operation of the machine vibration as “normal”, “fair”, “slightly rough”, etc. These various degrees of machine vibration are therefore, based on the individual’s physical perception between normal and abnormal roughness while the machine is operating.

It is agreed that this method can lead to differences in the classification of degree of vibration between individual observers. It is Robertshaw’s contention, and experience bears out this conclusion, that if the machine is operating satisfactorily as previously defined and the acceleration as measured by the Vibraswitch is within certain limits, the settings as outlined in the instructions will offer protection to the machine and prevent catastrophic failure.

For example, assume that a relatively new machine which, in the experience of the operator, is operating as “smooth” or “good” regarding vibration and the Vibraswitch measures this acceleration level to be 0.25 g above its static condition (zero). Experience suggests that a reasonable level for alarm conditions would be a minimum of twice this value or 0.5 g. It

must be acknowledged that such a definition of upper vibration limits (alarm condition) on the machine may not have adequately defined the upper tolerance limit of the machine before major repairs or excessive machine damage. It does, however, define a limit which, in our experience, has proven to be safe. As the user becomes more adept in using the Vibraswitch as a monitoring device, his experience may dictate a higher setpoint, more in keeping with the experience he has gained on the particular machine.

The Vibraswitch is adjusted by a simple three-step procedure (ref. Figure 4-2).

a. Zero Vibration Level Measurement

With the equipment on which the Vibraswitch is mounted **not** operating, back off the Setpoint adjusting screw counterclockwise (CCW) two turns and press the reset button. Then turn the Setpoint adjusting screw slowly clockwise (CW) until actuation occurs (the armature assembly is against the latch magnet, Figure 4-1). **This is the zero vibration point**, or actuating point, with the machine not operating. A mark should be made with a lead pencil or other convenient means to permanently record this “zero” vibration point. Subsequent measurements are made relative to this point.

NOTE

Actuation can be heard as an audible “click”. In noisy surroundings it may be necessary to use an ohmmeter or wire the Vibraswitch to the control circuit to tell when actuation occurs.

b. Normal g-level Measurements

With the machine (equipment) operating, back off the Setpoint adjusting screw one turn counterclockwise (CCW) and press the reset button. If the Vibraswitch will not reset, back off the Setpoint adjusting screw two turns counterclockwise (CCW) etc. Again turn the Setpoint adjusting screw slowly clockwise (CW) until actuation occurs. Mark this position with a lead pencil or other convenient means. **The difference between the two actuating points in Steps “a” and “b” is the normal g-level of the operating machine, in scale divisions.** One scale division is approximately 0.1 g; one full turn is approximately 1.0 g.

c. Final Setpoint Adjustment

If the “normal” g-level is less than 1.0 g above the zero level, rotate the Setpoint adjusting screw counterclockwise (CCW) 0.5 g (five graduations) from the point where actuation occurs in Step “b” above. If the “normal” g-level is greater than 1.0 g refer to Figure 4-3 for the proper Final Setpoint setting with respect to the “normal g-level vibration point” obtained in Step “b”. See example in Figure 4-3.

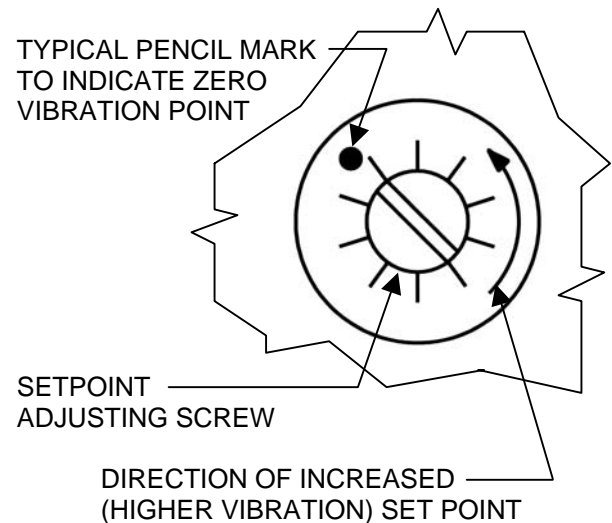

Each scale division is approximately 0.1 g.
Each full revolution is approximately 1 g.

Figure 4-2
Setpoint Adjustment

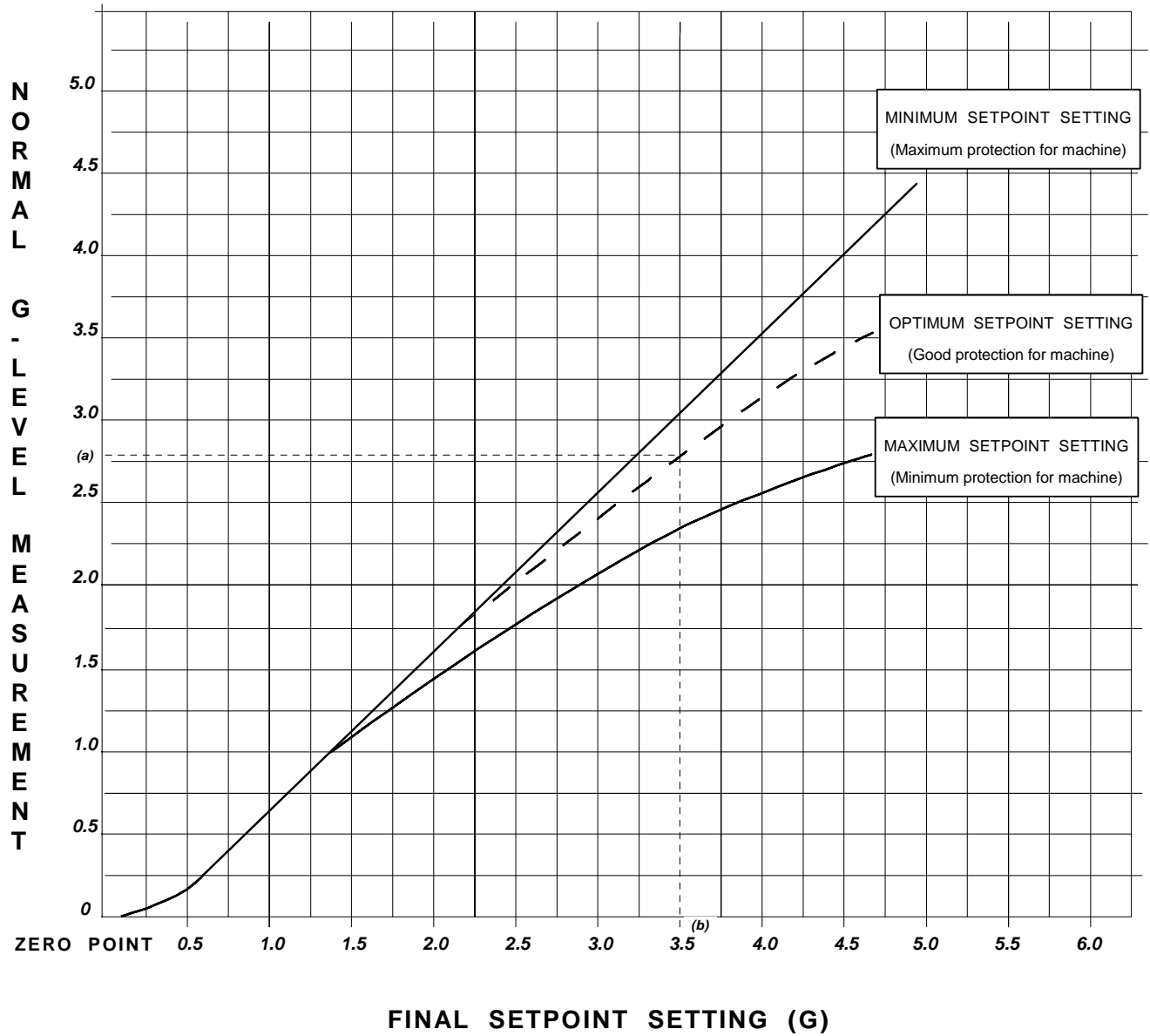

EXAMPLE: If the Normal G-Level (a) is 2.8 g above the Zero Vibration Level, the Final Setpoint Setting (b) should be set at 3.5 g above the Zero Vibration Level. Therefore, advance the Setpoint Adjusting Screw CCW 0.7 g ($3.5 \text{ g} - 2.8 \text{ g} = 0.7 \text{ g}$) or 7 scale divisions (one scale division is 0.1 g) from the Normal G-Level.

Figure 4-3
Setpoint Alarm Settings

Section 5 - MAINTENANCE

5.1 TROUBLE SHOOTING

Vibraswitches do not normally require any repair; however, listed below are some of the possible malfunctions that may occur and their recommended solutions.

NOTE

Whenever tightening cover bolts tighten to 75 – 105 inch lbs (8.5 – 11.9 Nm).

a. Functional Test (Ref. Figure 4-1)

This test may be performed with the Vibraswitch in its housing or removed from its housing. Therefore, it is not necessary to remove the housing from the machine.

1. Place the Vibraswitch on a table with the mounting surface or terminal blocks down on the table (setpoint adjusting screw and reset button facing up).
2. Press the reset button. If switch does not reset (armature latched on stop pin), turn setpoint adjustment screw CCW until switch can be manually reset.
3. Slowly turn setpoint adjusting screw CW until switch trips. This is the zero trip point which is the amount of spring tension required to overcome the 1 g force exerted by the earth's gravitational pull.
4. Note set point setting. One complete turn equals approximately 1 g. Setpoint scale is marked in 0.1 g increments. Turn setpoint adjustment screw one complete turn CCW. This is a 1 g setting above the earth's gravitational pull.
5. Manually reset the switch (press reset button).
6. With the reset button to your left and the Setpoint adjustment screw to your right, slowly rotate the Vibraswitch toward you 90°. The switch should trip when the mounting surface or terminal block is in a vertical plane and the earth's gravitational pull is not aiding the holddown (lower) magnet to hold the armature against the stop pin.

If the Vibraswitch does not pass the above test contact the nearest Robertshaw sales representative for repair or replacement of the Vibraswitch.

b. Vibraswitch Will Not Reset

1. **Dirt and/or metal chips on magnet** –
Clean magnets without removing or rotating them.

2. **Reset Assembly Binding** –

Check for interference from switch insulator.

3. **Broken Leaf Spring (Ref. Figure 4-1)** –

Not repairable in the field. Contact the nearest Robertshaw sales representative for repair or replacement of the Vibraswitch.

4. **Open Reset Coil** –

Check for continuity and proper coil resistance as specified in Table 5-1.

Table 5-1
Reset Coil Resistance

NOMINAL VOLTAGE	RESISTANCE (OHMS ± 10%)
24 VDC	55
48 VDC	230
117 VDC	850
120 VAC 240 VAC	Check for continuity. (Diode prevents actual resistance reading)

If coil fails continuity/resistance check replace coil or contact the nearest Robertshaw sales representative for repair or replacement of the Vibraswitch.

c. Unable to adjust Setpoint Setting to Obtain Tripping

Improper air gap between Holddown (lower) Magnet and Armature –

Not repairable in the field. Contact the nearest Robertshaw sales representative for repair or replacement of the Vibraswitch.

d. Switch does not actuate

Defective switch –

Verify by manually moving the Armature between the latched (tripped) position and the armed (reset) position and listen for an audible click of the switch. Verify contact by performing a continuity check.

If the internal switch is to be replaced or adjusted in the field make sure that the actuation point occurs at mid travel of the armature (lever).

5.2 REPLACEMENT PARTS

Table 5-2
Replacement Parts

PART DESCRIPTION	USED ON MODEL	PART NUMBER
Button, Reset*	ALL	420KB035-01
Cap Screw, Cover (4 used per unit)	ALL	435KB157-38
Coil, Reset, 24 VDC	365A-A2, E365A-A2	160KB044-03
Coil, Reset, 24 VDC	365A-D2, 365A-G2, E365A-D2, E365A-G2	160KB047-03
Coil, Reset, 48 VDC	365A-A4, E365A-A4	160KB044-02
Coil, Reset, 48 VDC	365A-D4, 365A-G4, E365A-D4, E365A-G4	160KB047-02
Coil, Reset, 117 VDC	365A-A7, E365A-A7	160KB044-07
Coil, Reset, 117 VDC	365A-D7, 365A-G7, E365A-D7, E365A-G7	160KB047-06
Coil, Reset, 120 VAC / 240 VAC	365A-A3, 365A-A8, 365A-D3, 365A-G3, E365A-A8	160KB044-06
Coil, Reset, 120 VAC / 240 VAC	365A-D8, 365A-G8, E365A-D8, E365A-G8	160KB047-05
Decal, Reset Button	ALL	159KB119
O-Ring, Cover Sealing	ALL	560KB083
Resistor, 240 VAC Reset Coil Circuit	365A-()3	260KB106-06
Resistor, Space Heater, 12 V	365A-A, E365A-A	260GG255
Resistor, Space Heater, 12 V	365A-D, 365A-G, E365A-D, E365A-G	904GC402-01
Resistor, Space Heater, 24 V	365A-A, E365A-A	260GG220
Resistor, Space Heater, 24 V	365A-D, 365A-G, E365A-D, E365A-G	904GC402-02
Resistor, Space Heater, 48 V	365A-A, E365A-A	260GG359
Resistor, Space Heater, 48 V	365A-D, 365A-G, E365A-D, E365A-G	904GC402-03
Resistor, Space Heater, 117/120 V	365A-A, E365A-A	260GG453
Resistor, Space Heater, 117/120 V	365A-D, 365A-G, E365A-D, E365A-G	904GC402-04
Resistor, Space Heater, 240 V	365A-A, E365A-A	260GG469
Resistor, Space Heater, 240 V	365A-D, 365A-G, E365A-D, E365A-G	904GC402-05
Resistor, Space Heater, 460 V	365A-A, E365A-A	260GG559
Resistor, Space Heater, 460 V	365A-D, 365A-G, E365A-D, E365A-G	904GC402-06
Screw, Setpoint Adjustment	ALL	435KB258-01
Switch, Type "A"	365A-A, E365A-A	909GM142-07
Switch, Type "D"	365A-D, E365A-D	900SA647-02
Switch, Type "G"	365A-G, E365A-G	900SA726-03
Varistor, 120 VAC	365A-A8, E365A-A8	260KB183
Varistor, 120 VAC	365A-D8, 365A-G8, E365A-D8, E365A-G8	904GC341
Varistor, 240 VAC	365A-A3	260KB183-03
Varistor, 240 VAC	365A-D3, 365A-G3	904GC341-01
Washer, Flat, Cover (4 used per unit)	ALL	447GB116

* When ordering the reset button, 420KB035-01, also order the Reset Button Decal, 159KB119.

5.3 REPAIRS

In some cases it may be necessary to replace parts in the field. When this is the case only the parts listed in Table 5-2 should be replaced in the field. All other parts require replacement by technicians experienced in the repair of Vibraswitches. Contact the nearest Robertshaw sales representative for repair or replacement of the Vibraswitch.

If an internal switch is to be replaced, the new switch should be adjusted so that it trips when the armature (lever) is at mid travel.

Warning - when replacing parts in the field, do not remove or readjust the magnets, stop pin, leaf springs, armature or any parts associated with the armature. (See Figure 4-1.)

5.4 ROUTINE MAINTENANCE

Vibraswitches do not normally require any maintenance, however, a periodic simple functional test and visual inspection is recommended. This should be performed at least once a year.

Functional tests and visual inspections should be performed with all power to the Vibraswitch disconnected and the equipment on which the Vibraswitch is mounted not running.

a. Simple Functional Test

1. Remove the Vibraswitch from the housing.
2. Note the position of the Setpoint adjusting screw.
3. Press the reset button to make sure that the Vibraswitch is in the armed position.
4. Slowly turn the Setpoint adjusting screw CW until the switch trips. This can usually be determined by hearing an audible click.
5. Rotate the Setpoint adjusting screw CCW until it is in the original position.
6. Press the reset button. The Vibraswitch should now be in the armed (reset) position.

b. Visual Inspection

1. Inspect the Vibraswitch mechanism and housing interior for signs of corrosion and moisture.
2. Replace the Vibraswitch into the housing.
3. Tighten cover bolts tighten to 75 – 105 inch lbs (8.5 – 11.9 Nm).

c. Recalibration

This should not be necessary, however, if it is felt that the setpoint may not be correct refer to paragraph 4.2.



U.S.A. & Canada

Robertshaw Industrial Products
1602 Mustang Drive
Maryville, Tennessee 37801
Phone: (865) 981-3100 Fax: (865) 981-3168
<http://www.robertshawindustrial.com>

Exports

Invensys Controls
1701 Byrd Avenue
P.O. Box 26544
Richmond, Virginia 23261-5644
Phone: (804) 756-6500 Fax: (804) 756-6561