

MODELS CUB 1 & CUB 2 COUNTERS OPEN UP NEW COUNTING HORIZONS, FROM COUNTING SIMPLE SWITCH CONTACT CLOSURES



CUB 1 MINIATURE
 ELECTRONIC COUNTER



CUB 2 GENERAL PURPOSE
 INDUSTRIAL COUNTER

- TO HIGH SPEED PULSES FROM TTL, CMOS, OR OTHER ELECTRONIC SOURCES
- AT A PRICE LESS THAN EQUIVALENT E.M.[ELECTRO-MECHANICAL] COUNTERS

The heart of the CUB is a tiny custom silicon chip developed by Red Lion Controls. This chip contains all of the counting and display circuits in an area less than 0.02 (0.5 mm) square inches. Via "micro-assembly", the chip and other peripheral parts are attached to a substrate with the electrical connections being made ultrasonically - using wire approximately 1/3 the diameter of a human hair. The result is an entirely new concept in counting, that is not only cost effective, but opens the door to counting applications that until now were not economically feasible.

AND HERE ARE SOME MORE ADVANTAGES:

SELF POWERED

Self-Contained batteries eliminate the need for external power and prevent loss of count if power fails. Also provides for remote or portable applications. Battery operation also means elimination of shock hazard and allows the use of 2-conductor bell wire for count signals and micro-power input signals.

Batteries are easily replaceable (2 "N" Cells, alkaline) and average battery life is four years.

HIGH SPEED

The 5 KHz count speed is at least 100 times faster than "high performance" E.M. counters. This opens up vast new application areas that previously were impossible, or at best, accommodated by expensive electronic counters costing 5 to 10 times as much.

FLEXIBILITY

Various count inputs allow use with switch contacts or high speed pulse outputs from electronic sensors and circuits. The reset function can be disabled, set up for front panel reset, remote reset, or both.

NO-WEAR, NO-NOISE

The CUB's micro-circuits can accurately and silently accumulate enough counts in one hour to completely wear out an ordinary E.M. counter. More over, it can repeat this performance 3500 times (4 years) with just one set of batteries.

RELIABILITY

Internal "micro-assembly" construction withstands many times the "G" force of shock and vibration compared to conventional construction.

CUB counters also feature elastomeric contacts. This eliminates long term problems associated with contact corrosion.

Battery operation, a high degree of input filtering, plus an inherent common mode rejection ratio of more than 120 dB @ 50/60 Hz, provides ultra-high immunity from electrical noise interference.

RUGGED, SEALED FRONT-PANEL CONSTRUCTION

Housed in a die-cast metal case, CUB counters are front panel sealed and designed to meet NEMA 4/IP65 specifications, for wash-down and/or dust when properly installed.

SPECIFICATIONS

1. **DISPLAY:** 6-digit LCD
CUB 1: 0.2" (5 mm) high
CUB 2: 0.35" (9 mm) high
2. **POWER SOURCE:** No external power required. Operates from 2 "N" type alkaline batteries (supplied separately). Battery life up to 4 years or more. (See Note, at right.)
3. **COUNT & RESET INPUT SIGNALS:** Adapts to Count-Switch Contact Signals, Open-Collector Transistor Outputs, and Bi-Polar Drive Outputs as shown in the diagrams on the following page. Counter increments and resets on negative going (pull down) transition of count or reset signal.
4. **OPERATING TEMPERATURE RANGE:** 0° to 50°C (32° to 122°F)
5. **STORAGE TEMPERATURE RANGE:** -20° to +60°C (-4° to +140°F)

6. **COUNT SPEED:** Up to 50 Hz with switch contact input (counters have internal de-bounce circuits) or up to 5 KHz with solid-state electronic input (See diagrams on following page).

Note: Only Alkaline Cells are recommended for use with CUB Counters. **DO NOT USE CARBON-ZINC BATTERIES** since they have short life times and can leak electrolyte causing internal corrosion damage. When using switch contacts for count input or remote reset, normally open contact circuits are recommended. Switch contacts that remain normally-closed and are opened only briefly to signal a count, can reduce battery life to somewhat less than 4 years.

USE CUB COUNTERS WITH:

- VCM • VOLTAGE CONVERTER MODULES for isolated, A.C., control voltage count inputs to 270 VAC,
 - LCM • LOGIC CONVERTER MODULES for interface with standard logic voltages & outputs,
 - PSMA • POWER SUPPLY & INTERFACE MODULE for operation with electronic sensors.
- [See Accessory Section Of The Catalog]

APPLICATION FLEXIBILITY VIA RECONNECT OPTIONS

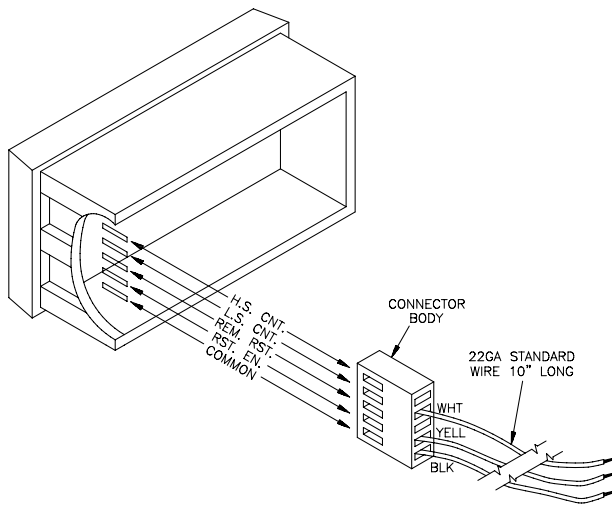

Selection of desired operating modes is easily done by adding or moving terminal leads in the Input Connector Body. The connector body is polarized to prevent incorrect insertion, and locked in place by the battery cover to avoid accidental disengagement. Connectors are supplied with the 3 leads installed as shown below. A spare blue lead is supplied in the hardware pack.

TO REMOVE TERMINAL, insert blade of a small screwdriver into slot of connector body, and gently push in to disengage lock pawl. Pull terminal out. **WHEN INSERTING TERMINAL** into connector body, make sure the lock pawl is toward the slot in the body. Push terminal in until lock pawl snaps into slot.

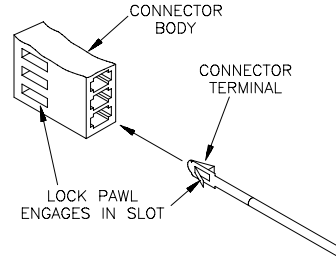

LOW SPEED COUNT INPUT, 50 Hz MAX. [For 250 Hz see note in text]

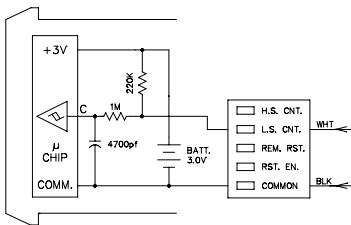

Pulling the L.S. CNT. Input to Common with a mechanical or solid-state switch increments the counter. The low pass filter (1meg resistor and 4700 pf cap) used with a Schmidt trigger circuit debounces mechanical switch signals. The switch load is 14 μ A (max. voltage drop 0.5 V) when ON. OFF-state leakage current must be less than 2 μ A.

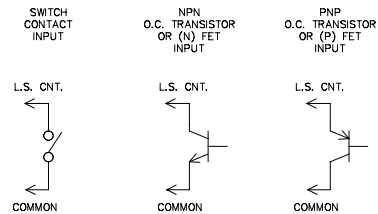

Reed switches, mercury wetted contacts, snap action limit switches, and silver alloy relay contacts with wiping action are usually satisfactory for generating count input signals. Motor starter contacts, tungsten contacts, and brush-type contacts should **NOT** be used.

Note: By parallel connecting both H.S. CNT. and L.S. CNT. inputs, count speed can be increased to 250 Hz if de-bounce is not needed.

HIGH SPEED COUNT INPUT, 5 KHz MAX.

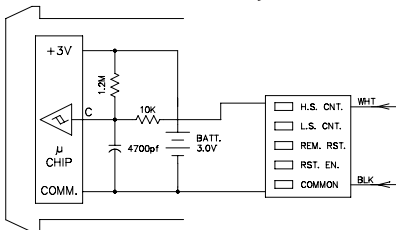

Moving the white wire to the H.S. CNT. Input allows the CUB Counter to operate at speeds up to 5 KHz when driven by bi-polar outputs or external circuits having an output impedance of 3.3 K Ω or less. Input drive voltage must be limited to 3.0 V maximum to avoid a charging current into the batteries which can cause premature battery failure or leakage. CMOS and TTL Logic outputs can be loaded with a resistor (R_L) to limit drive voltage, or a voltage divider can be used as shown for the PNP O.C. Transistor output.

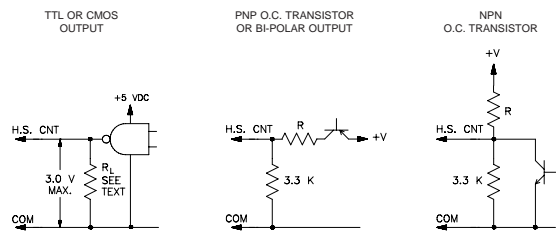

INPUT PULSE EXCURSION LIMITS

$$V_{IN} (High) = +2.7 V \text{ min. } +3.3 V \text{ max.}$$

$$V_{IL} (Low) = +0.5 V \text{ max.}$$

Note: The PSMA Power Supply and Interface Module used for powering RLC sensors with CUB Counters, has proper interface output for direct drive to H.S. CNT.

RESET OPTIONS

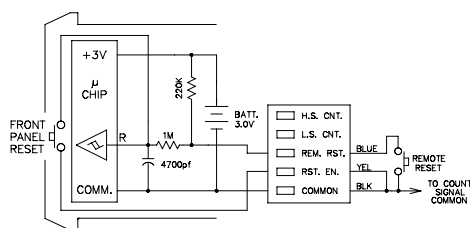

Connecting the RST. EN. (Reset Enable) Input to Common activates the front panel Reset button. When the front panel Reset button is to be deactivated, remove the yellow wire from the RST. EN. Input.

When Remote Reset is required, the blue wire in the hardware pack is inserted in the REM. RST. Input. Pulling this input low causes the counter to reset. The REM. RST. can be pulled low by either a mechanical switch or solid-state transistor switch. Switch load and leakage are the same as for L.S. CNT. Input above.

Note: The RC protection circuit on the REM. RST. Input causes a delay of approximately 6 msec in Reset response.

DIMENSIONS, INSTALLATION, & BATTERY INSERTION

After cutting opening in panel, slide the panel gasket over the rear of the counter body to the back of the bezel. Then slide counter through the panel cut-out. Install mounting clips on each side of counter body with mounting screws.

CUB 1

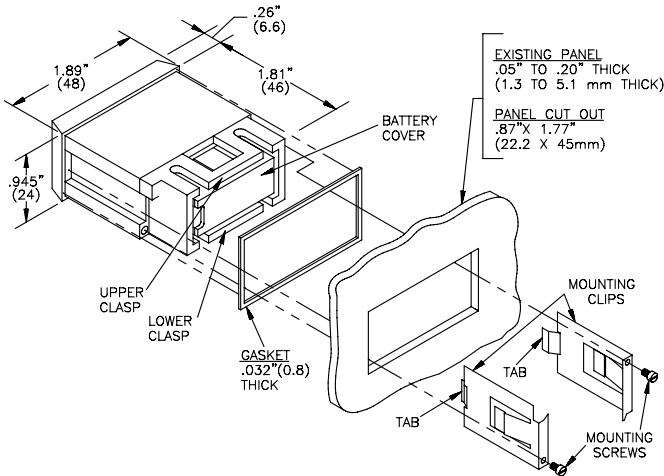

CUB 2

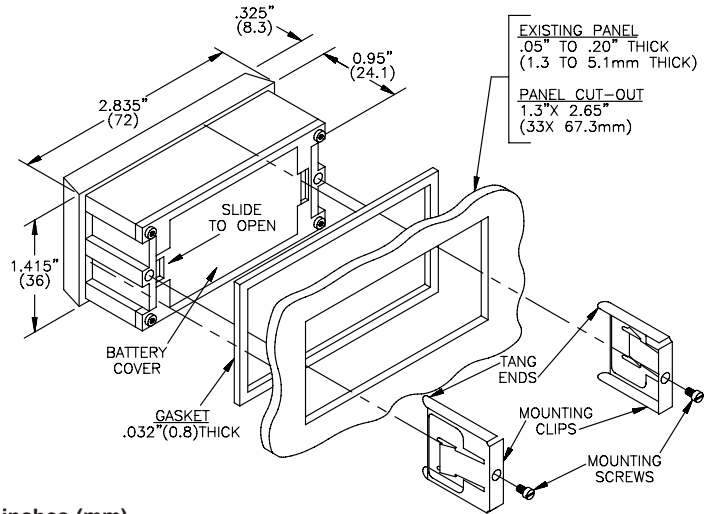

DIMENSIONS In inches (mm)

BATTERY COVER REMOVAL & BATTERY INSERTION

CUB 1

The battery cover is held in place by upper and lower clasps that capture mating lock ramps on the cover. To remove, insert thumbnail and index finger nail in the gaps between the upper and lower clasps and the battery cover, and deflect the clasps slightly to clear the edges of the ramps while pulling out on the cover. To replace cover, simply push into place until both clasps snap into engagement with lock ramps.

CAUTION: Do not deflect clasps more than necessary to clear lock ramps. Excessive deflection can cause clasps to break off.

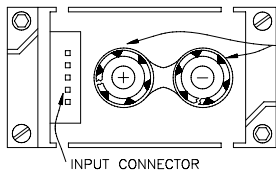

BATTERIES SHOWN IN PLACE: CENTER (+) OUT, RIGHT (-) OUT.

CUB 2

Slide battery cover to the left until the right hand lip disengages and pops out. To reinstall cover, insert left hand lips into case first, push cover to the left until right hand lip drops down and cover snaps back into place. Install batteries as shown below observing proper polarity.

Note: Push battery spring clips to the left (toward connector) to completely free the batteries when removing or installing batteries. Conductive rubber battery contacts can be torn from their retaining pins if batteries are forced in.

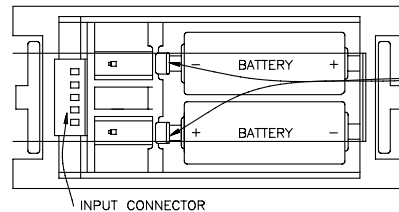

PUSH CONTACT SPRINGS TOWARD CONNECTOR TO ALLOW BATTERIES TO DROP IN FREELY. DO NOT PUSH OR FORCE BATTERIES INTO PLACE.

ELECTRICAL CONNECTIONS

There are certain considerations that should be observed when running the count and control signal wires. A length of wire can act like an antenna and the closer it is to a source of electrical noise, the more it becomes susceptible to that noise.

There are a few rules that should be followed when running these wires.

1. Never run count or control signal wires in the same conduit or raceway with AC power lines, conductors that feed motors, solenoids, SCR controls, heaters, etc.

2. Signal wires within enclosures should be routed as far away as possible from contactors, control relays, transformers, and other noisy components.
3. When shielded wire is used, connect the shield to the common of the CUB unit, and leave the other end of the shield disconnected and insulated from machine ground.
4. Mount the CUB in a panel that is grounded to the machine frame.
5. When using accessory devices such as LCMs or PSMs into the H.S. CNT. Input, the accessory devices should be mounted near the CUB Counter.

ORDERING INFORMATION

MODEL NO.	DESCRIPTION	PART NUMBERS
CUB 1	CUB 1 Miniature Electronic Counter	CUB10000
CUB 2	CUB 2 Gen. Purpose Industrial Electronic Counter	CUB20000
BNA	"N" Type Alkaline Batteries (Note 1)	BNA00000
HWK 1	CUB 1 Spare Hardware Kit (Note 2)	HWK10000
HWK 2	CUB 2 Spare Hardware Kit (Note 2)	HWK20000
ICA	Spare Input Connector & Terminal Wires (Note 3)	ICA00000

For more information on Pricing, Enclosures & Panel Mount Kits refer to the RLC Catalog or contact your local RLC distributor.

NOTES

1. Batteries NOT supplied with counters, order separately.
2 required per unit.
2. Counters supplied with required hardware. Includes 2 mounting clips & screws, panel gasket, 2-wire nuts & blue terminal wire.
3. Counters supplied with connector body & white, yellow, & black wires. Kit ICA includes connector body & one each of black, white, blue, & yellow terminal wires.

LIMITED WARRANTY

The Company warrants the products it manufactures against defects in materials and workmanship for a period limited to two years from the date of shipment, provided the products have been stored, handled, installed, and used under proper conditions. The Company's liability under this limited warranty shall extend only to the repair or replacement of a defective product, at The Company's option. The Company disclaims all liability for any affirmation, promise or representation with respect to the products.

The customer agrees to hold Red Lion Controls harmless from, defend, and indemnify RLC against damages, claims, and expenses arising out of subsequent sales of RLC products or products containing components manufactured by RLC and based upon personal injuries, deaths, property damage, lost profits, and other matters which Buyer, its employees, or sub-contractors are or may be to any extent liable, including without limitation penalties imposed by the Consumer Product Safety Act (P.L. 92-573) and liability imposed upon any person pursuant to the Magnuson-Moss Warranty Act (P.L. 93-637), as now in effect or as amended hereafter.

No warranties expressed or implied are created with respect to The Company's products except those expressly contained herein. The Customer acknowledges the disclaimers and limitations contained herein and relies on no other warranties or affirmations.

Red Lion Controls
20 Willow Springs Circle
York PA 17402
Tel +1 (717) 767-6511
Fax +1 (717) 764-0839

Red Lion Controls BV
Basicweg 11b
NL - 3821 BR Amersfoort
Tel +31 (0) 334 723 225
Fax +31 (0) 334 893 793

Red Lion Controls AP
31, Kaki Bukit Road 3,
#06-04/05 TechLink
Singapore 417818
Tel +65 6744-6613
Fax +65 6743-3360