

PENBERTHY

Section	4000
Instal. Instr.	4951
Issued	10/97
Replaces	09/96

Model MGS-314 / 314D Level Control Switch

(For use with the *MULTIVIEW™* Liquid Level Meter)

Third Party Approvals for the MGS-314D Switch Are Pending

Installation/Operation/Maintenance Instructions

TABLE OF CONTENTS

Revision G

Product Warranty	i
1.0 Introduction	1
2.0 Specifications/Approvals	1
2.1 Enclosure	1
2.2 Switch	1
2.3 Approvals	1
3.0 Theory of Operation	2
4.0 Installation	2
4.1 Unpacking	2
4.2 Mounting the Switch	3
4.3 Wiring Connection	4
5.0 Set-Up	4
5.1 Initial Test	5
6.0 Pump-Control Set-up	5
6.1 Interval Relay Wiring	5
7.0 Troubleshooting	6
7.1 Introduction	6
7.2 Switch Test	6
7.3 Actuation Test	6
8.0 Telephone Assistance	6
Appendix A:	
Operation Information on the Model WE77/Ex-JR Interval Relay	10
Appendix B:	
Connection Diagram for the WE77/Ex-JR Interval Relay	11

PRODUCT WARRANTY

Penberthy Inc., warrants its products as designed and manufactured by Penberthy to be free of defects in material and workmanship for a period of **one year** after the date of installation or **eighteen months** after date of manufacture, whichever is earliest. Penberthy will, at its option, replace or repair any products which fail during the warranty period due to defective material or workmanship.

Prior to submitting any claim for warranty service, the owner must submit proof of purchase to Penberthy and obtain written authorization to return the product. Thereafter, the product shall be returned to Penberthy in Prophetstown, Illinois, with freight prepaid.

This warranty shall not apply if the product has been disassembled, tampered with, repaired or altered outside of the Penberthy factory, or if it has been subjected to misuse, neglect or accident.

Penberthy's responsibility hereunder is limited to repairing or replacing the product at its expense. Penberthy shall not be liable for loss, damage, or expenses directly or indirectly related to the installation or use of its products, or from any other cause or for consequential damages. It is expressly understood that Penberthy is not responsible for damage or injury caused to other products, building, property or persons, by reason of the installation or use of its products.

THIS IS PENBERTHY'S SOLE WARRANTY AND IN LIEU OF ALL OTHER WARRANTIES, EXPRESSED OR IMPLIED WHICH ARE HEREBY EXCLUDED, INCLUDING IN PARTICULAR ALL WARRANTIES OF MERCHANTABILITY OR FITNESS FOR A PARTICULAR PURPOSE.

This document and the warranty contained herein may not be modified and no other warranty, expressed or implied, shall be made by or on behalf of Penberthy unless modified or made in writing and signed by the President or a Vice President of Penberthy.



1.0 Introduction

The instructions in this manual pertain to the Penberthy Model MGS-314 or MGS-314D Magnetic Level Meter Switch.

The Model MGS-314 / 314D Magnetic Level Meter Switch is designed to detect the passage of the float in a MULTIVIEW™ Magnetic Liquid Level Meter, at a specific location. The switch consists of a snap-action switch and a magnetic actuation assembly encased in a watertight (Type 4), explosion-proof (Type 7) enclosure.

2.0 Specifications/Approvals

2.1 Enclosure

Watertight (Type 4) and Explosion-proof (Type 7) cast aluminum housing; Buna-N O-ring.

2.2 Switch

Output

MGS-314: SPDT (Form C) switch output: 5 Amps at 125/250/277 Vac, non-inductive load.

MGS-314D: DPDT (2x Form C) switch output: 10 Amps at 125/250 Vac, non-inductive load.

Repeatability

Better than 1/32".

Response Time

100 milliseconds.

Operating Temperature

-40°C to 185°C (-40°F to 365°F) - With Third Party Approvals (FM & CSA)

-40°C to 340°C (-40°F to 645°F) - Without Third Party Approvals

Dead Band

+/- 1/2"

2.3 Approvals

FM Approved

Explosion-proof for:

Division 1, 2;

Class I; Groups B, C, D;

Class II; Groups E, F, G;

Class III; Type 4

When installed in accordance with Penberthy Drawing # 7E741-009 (Figure #3)

FM Approved

Intrinsically Safe for:

Division 1, 2;

Class I; Groups A, B, C, D;

Class II; Groups E, F, G;

Class III; Type 4

When installed in accordance with Penberthy Drawing # 7E742-009 (Figure #4)

CSA Approved Ex d

Explosion-proof for:

Division 1, 2;

Class I; Groups B, C, D;

Class II; Groups E, F, G;

Class III; Type 4

When installed in accordance with Penberthy Drawing # 7E741-009 (Figure #3)

CSA Approved Exi a

Intrinsically Safe for:

Division 1, 2;

Class I; Groups A, B, C, D;

Class II; Groups E, F, G;

Class III; Type 4

When installed in accordance with Penberthy Drawing # 7E742-009 (Figure #4)

3.0 Theory of Operation

While reading the theory of operation refer to Figure #1 [MGS-314] or Figure #2 [MGS-314D] for the location of the components. The description is based on a side view.

With the liquid level below the switch, the toggle magnet should be at position "A". It is held in this position by an attractor near the magnet at the bottom of the toggle. As the float ascends and passes the switch, the draw between the float magnet and toggle magnet is sufficient to overcome the attractor. Consequently, the toggle moves to position "B" and is held in place by a second attractor. The movement of the toggle causes the switch (or switches) to change state.

As the float descends with the liquid level it passes the switch and the process described is reversed. The toggle returns to position "A" and the switch returns to its original state.

4.0 Installation

4.1 Unpacking

Upon receiving the Model MGS-314 / 314D Magnetic Level Meter Switch, check all components carefully for damage incurred in shipping. If damage is evident or suspected, do not attempt installation. Notify the carrier immediately and request a damage inspection. Check each item against the packing list.

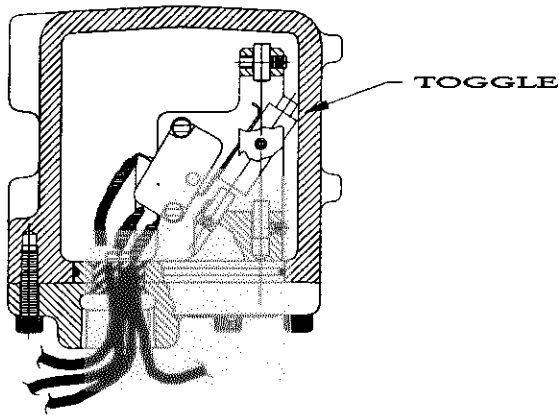

Position "A"

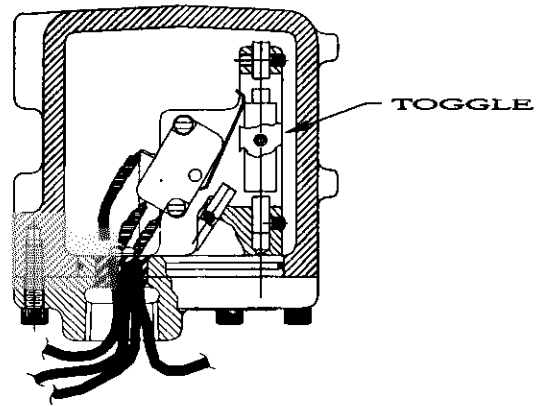

Position "B"

Figure #1

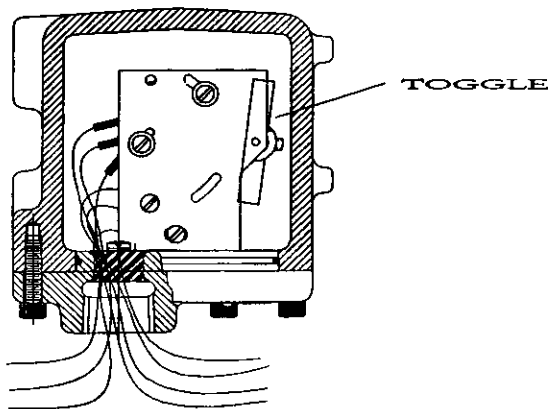

Position "A"

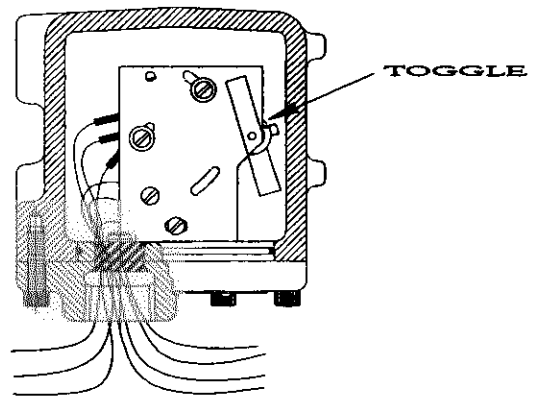

Position "B"

Figure #2

4.2 Mounting the Switch

Due to shipping vibration, it is possible the magnet toggle will not be in the "normal" position for proper operation. If this occurs, simply cycle the float past the switch once. This will automatically initialize it.

- 1.) Measure the distance from the top of the indicating scale, on the Magnetic Level Meter, to the top of the communicating chamber. Record this distance.
- 2.) Loosen the clamps holding the indicating scale to the communicating chamber.

- 3.) Open the mounting band supplied with the MGS-314 / 314D, and put it around the communicating chamber, under the indicating scale.
- 4.) Place the MGS-314 / 314D on the communicating chamber with the cooling fins facing 180° away from the communicating chamber and with the conduit opening facing down.
- 5.) Put the mounting band between the cooling fins in the channel provided.
- 6.) Loosely tighten the mounting band. Move the MGS-314 / 314D either up or down to the desired position, and tighten the band.
- 7.) The switch must be mounted within the indication range for the magnetic gage. The mounting band for the switch should be a minimum of 1" inside the indication range. This will insure sufficient float movement to operate the switch.
- 8.) If more than one switch is used on a single magnetic gage, the minimum recommended distance between mounting bands is 3".
- 9.) Adjust the position of the indicating scale so that the distance from the top of the scale to the top of the communicating chamber is the same as in Step #1. Tighten the clamps holding the indicating scale to the communicating chamber.

4.3 Wiring Connection

- 1.) If you are using conduit for the switch wiring use a conduit seal with a drain or a drip-loop to prevent condensate from entering the housing. Condensate can cause electrical shorts.

The switch housing has a 1/2" NPT-F connection for the wiring conduit.

- 2.) We recommend attaching an aluminum conduit, via a 300 series stainless steel nipple, to the conduit opening of the switch housing. This will give you an accessible point to terminate the control wires. **DO NOT USE** any ferromagnetic material such as: carbon steel, duplex, 400 series stainless steel or cast iron.

5.0 Set-up

! DANGER !

Energizing the switch with the cover removed can cause ignition of flammable materials or atmospheres, resulting in personal injury, death or property damage.

Do not apply power to the switch while performing these tests.

5.1 Initial Test

Model	Toggle Orientation	Wire Color					
		Black	Red	Blue	Orange	White	Violet
MGS-314	Toggle at position "A" (liquid level below switch)	Common	Open	Closed	NA	NA	NA
	Toggle at position "B" (liquid level above switch)		Closed	Open	NA	NA	NA
MGS-314D	Toggle at position "A" (liquid level below switch)	Common (for Blue and White)	Common (for Orange and Violet)	Open	Open	Closed	Closed
	Toggle at position "B" (liquid level above switch)			Closed	Closed	Open	Open

Use an ohmmeter to verify the following conditions.
If these conditions do not exist, go to Section 7.0.

6.0 Pump-Control Set-up

By combining two MGS-314 / 314D switches with the interval relay (WE77/Ex-JR) you can achieve intrinsically safe pump-control.

6.1 Interval Relay Wiring

MGS-314

For pump-up action connect the red and black wires from the high level switch to Terminals #1 and #2. Connect the red and black wires from the low level switch to Terminals #8 and #9. The jumpers should be between Terminals #3 and #4, and Terminals #6 and #7.

For pump-down action connect the high level switch to Terminals #8 and #9, and the low level switch to Terminals #1 and #2. Leave the jumpers in the same position as pump-up action. For technical information on the WE77/Ex-JR see Appendix A.

Two 10kΩ resistors must be installed in parallel across the leads as close to the MGS-314 switches as possible. One across leads #1 and #2, the other across leads #8 and #9.

MGS-314D (Assume the Toggle is at position "A" for the following directions)

For pump-up action connect one common and a corresponding open connection from the high level switch to Terminals #1 and #2. Connect the same color combination from the low level switch to Terminals #8 and #9. The jumpers should be between Terminals #3 and #4, and Terminals #6 and #7.

For pump-down action connect the high level switch to Terminals #8 and #9, and the low level switch to Terminals #1 and #2. Leave the jumpers in the same position as pump-up action. For technical information on the WE77/Ex-JR see Appendix A.

Two 10k Ω resistors must be installed in parallel across the leads as close to the MGS-314D switches as possible. One across leads #1 and #2, the other across leads #8 and #9.

7.0 Troubleshooting

7.1 Introduction

Your Penberthy Magnetic Level Meter Switch is designed to give you years of unattended service. However, failure of electrical equipment can occur. Sound maintenance practices require periodic inspection of the instrument to ensure it is in good working order.

! DANGER !

Energizing the switch with the cover removed may cause ignition of flammable materials or atmospheres, resulting in personal injury, death or property damage.

Do not apply power to the switch while performing these tests

7.2 Switch Test

With the switch toggle at position "A" use an ohmmeter to verify the conditions in section 5.1. If these conditions are not met remove the (9) socket head cap screws holding the housing together. With the ohmmeter still connected manually close the switch. If the switch still doesn't change state, it is defective. Go to Section 8.2.

7.3 Actuation Test

If the switch works (see Section 7.2) check the toggle magnet [MGS-314] or toggle magnet/cam [MGS-314D]. It should travel freely with a minimum of lateral (side-to-side) motion. This can be adjusted by loosening or tightening the two dog point setscrews that the toggle magnet pivots on [MGS-314 only]. If the nylon tips are damaged replace the setscrews.

8.0 Telephone Assistance

If you are having problems with your Penberthy Level Meter Switch, notify your local Penberthy distributor, or call the factory direct at (815) 537-2311 and ask for an applications engineer.

To help us to assist you more effectively, please have as much of the following information as possible when you call:

- **Instrument Model # (MGS-314 / 314D)**
- **Name of the company from whom you purchased the switch**
- **Invoice # and date**
- **Process Material**
- **Process Temperature**
- **Brief description of the problem**
- **Checkout procedures (from the instruction manual) that failed**

If attempts to solve your problem fail, you may be requested to return your instrument to the factory for testing. You must obtain a Return Authorization (R.A.) number from your authorized Penberthy distributor prior to returning your unit. Failure to do so will result in the unit being returned to you, without being tested and freight collect. To obtain an R.A. number collect the following information:

- **Reason for return**
- **Person to contact at your company**
- **"Ship-To" address**

There will be a minimum charge applied for evaluation of non-warranty units. You will be contacted before any repairs are performed if they will result in additional charges in excess of the minimum. If you return a unit that is under warranty but not defective, the minimum charge will apply.



Figure #3

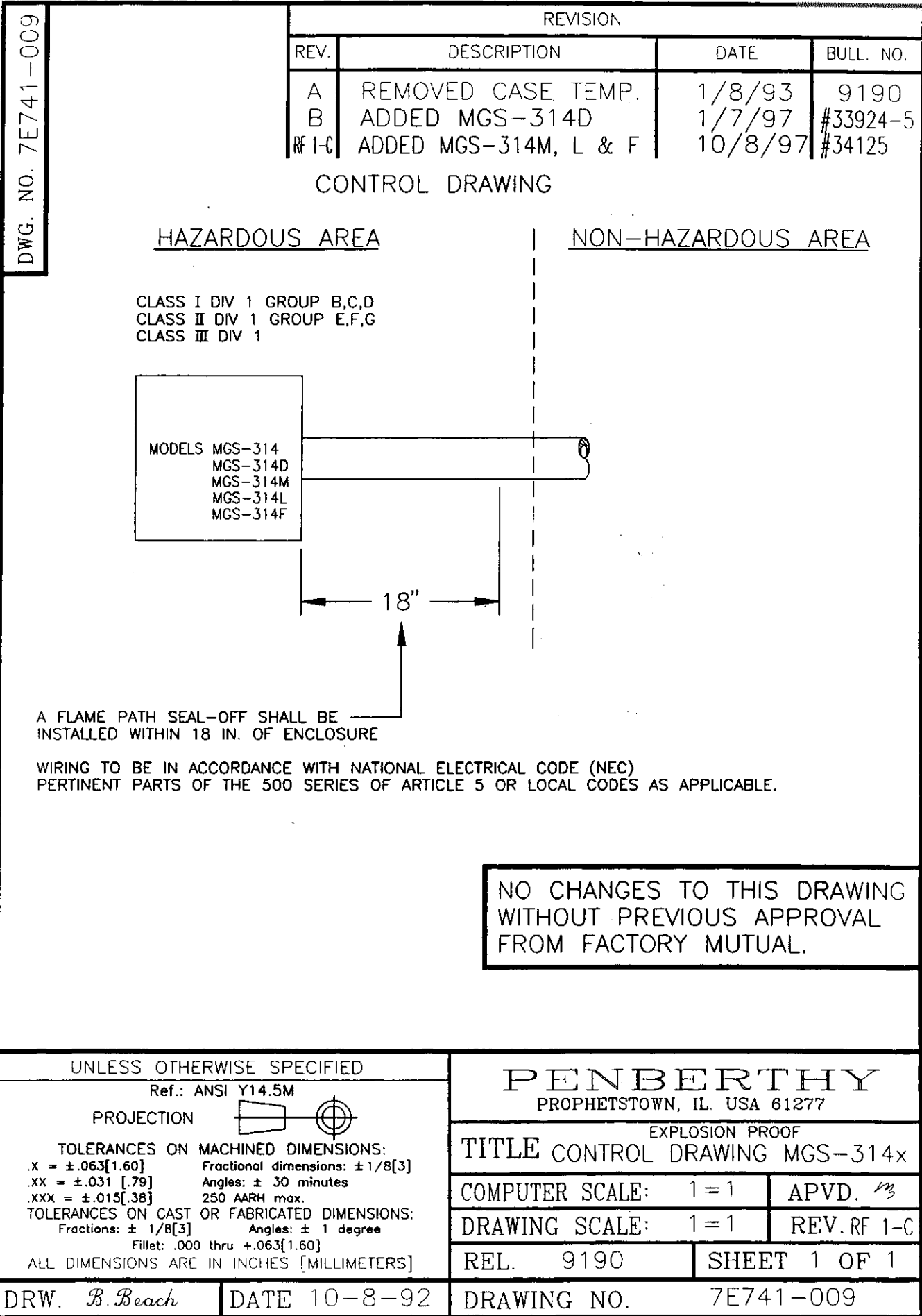
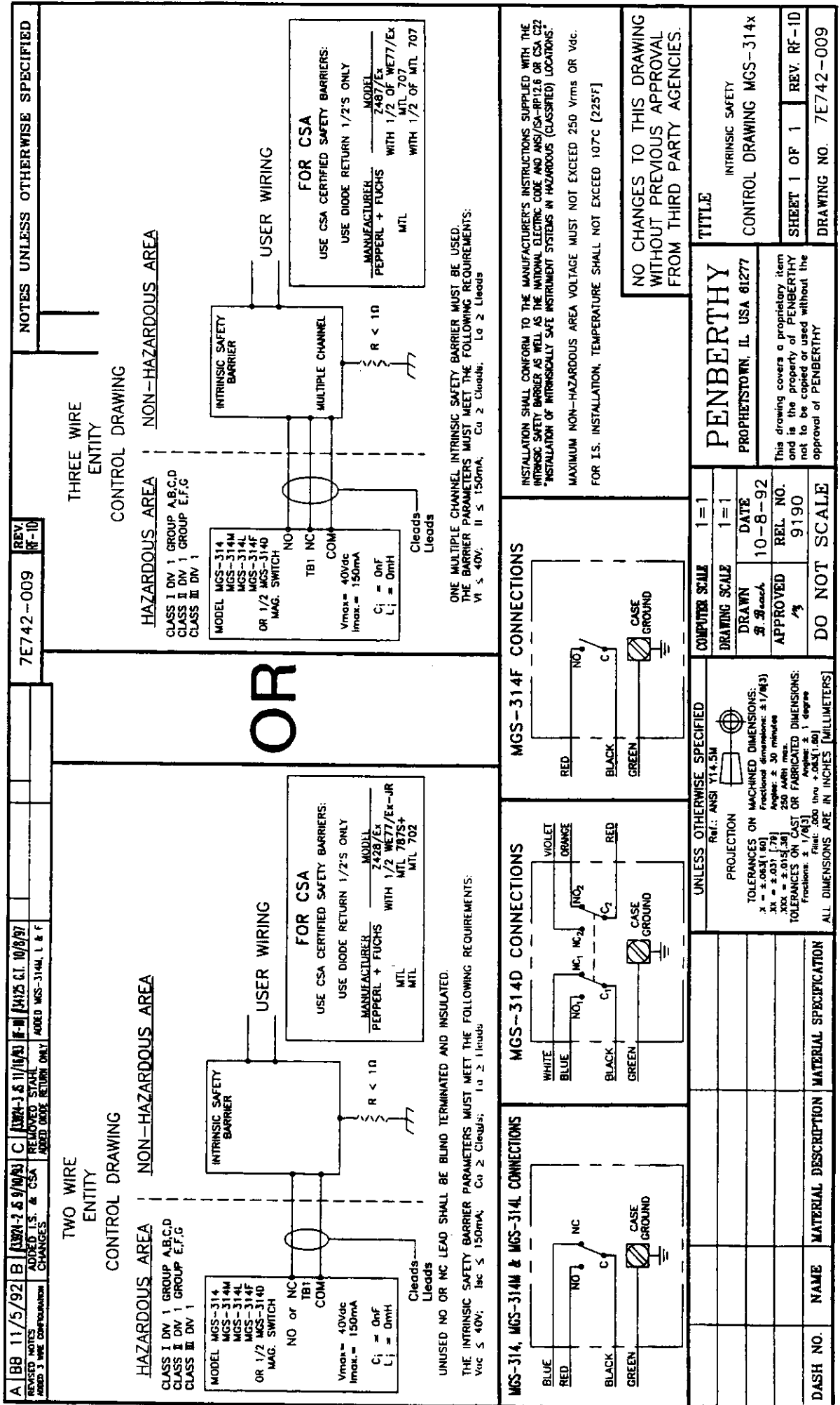

Figure #4



APPENDIX A

Model WE77/Ex-JR -- Interval Relay

Operation

Mode Condition

Standard preset: Jumper between Terminals 3 and 4 and Terminals 6 and 7.

Lead breakage monitor: Built-in circuitry monitors both control circuits for lead breakage. If the current in one of the two control circuits falls below 0.1mA, the relay will de-energize.

Output relay condition at power supply interruption: When power is reconnected, the output relay returns to its state prior to the interruption.

Typical Applications

Pump-up application with two MGS-314 / 314D

Magnetic Level Meter Switches.

- Level 1: Relay energized
- Level 2: Relay remains energized
- Level 3: Relay de-energizes
- Level 4: Relay remains de-energized
- Level 5: Relay energizes

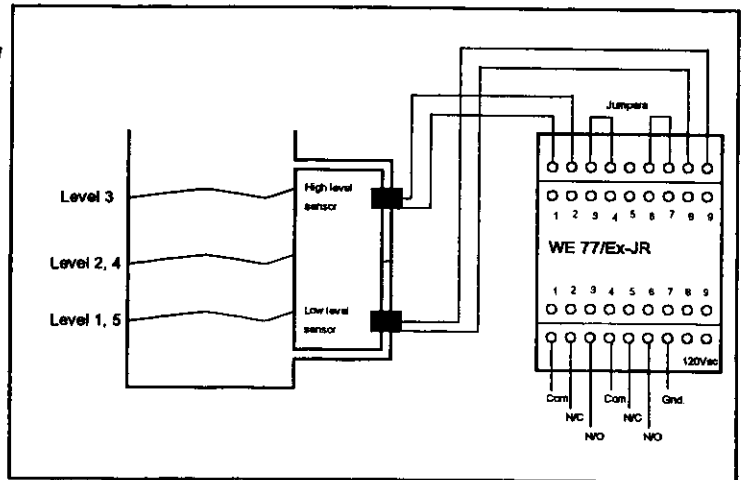

Pump-down application with two MGS-314 / 314D Magnetic Level Meter Switches

- Level 1: Relay de-energized
- Level 2: Relay remains de-energized
- Level 3: Relay energizes
- Level 4: Relay remains energized
- Level 5: Relay de-energizes

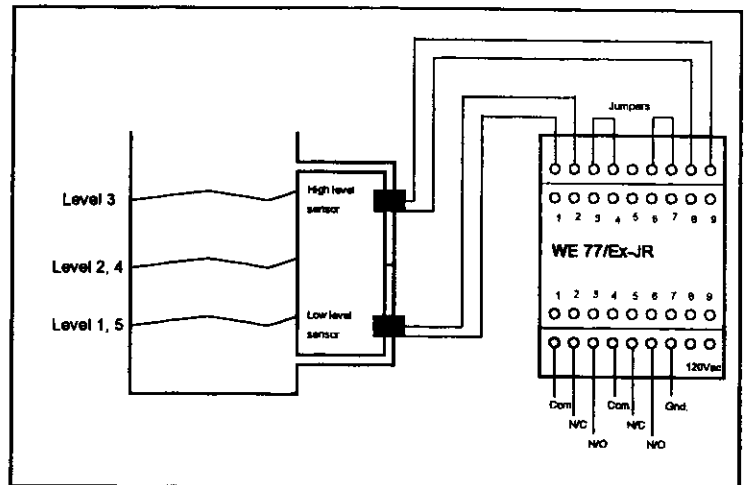

APPENDIX B

Model WE77/Ex-JR -- Interval Relay

Connection Diagram

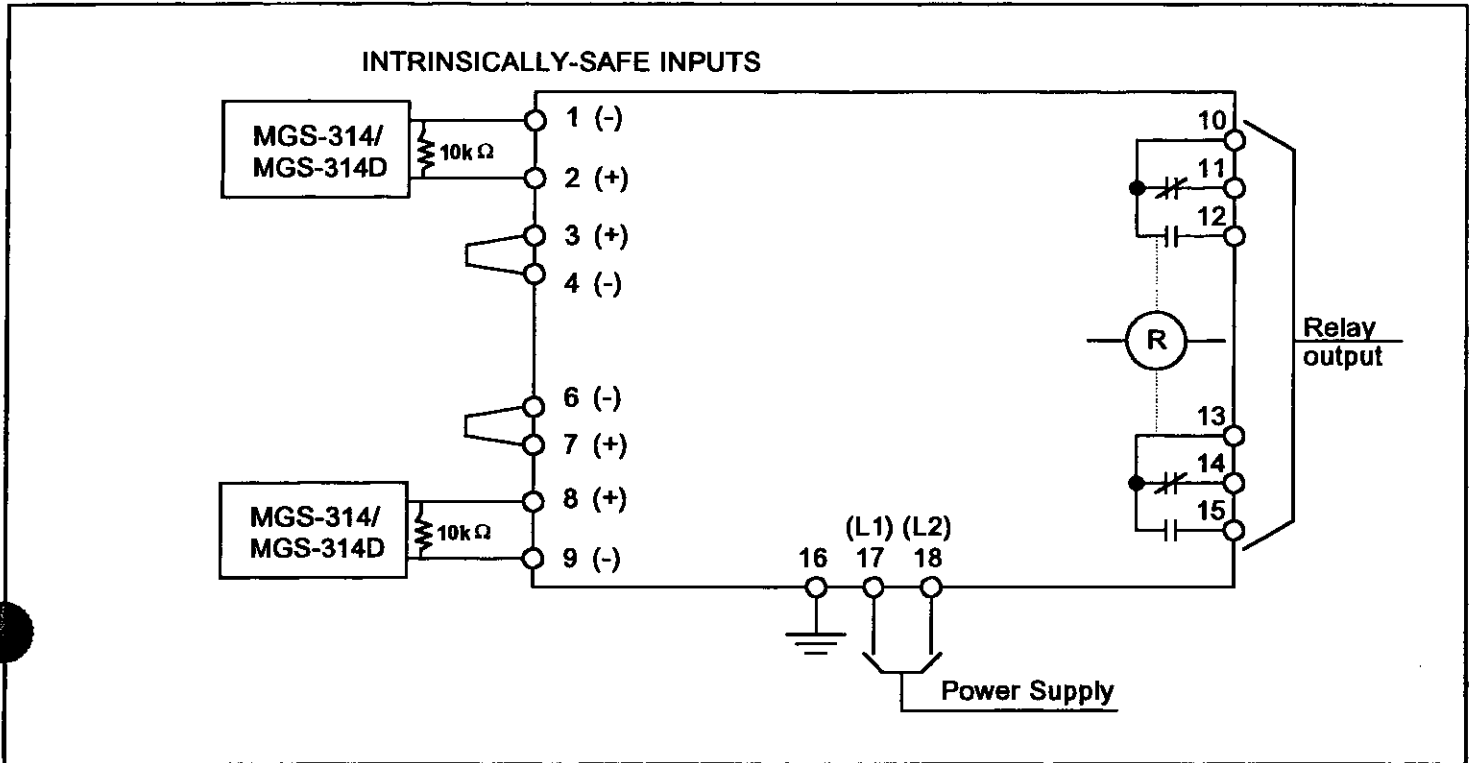

Two 10kΩ resistors must be installed in parallel across the leads as close to the MGS-314 / 314D switches as possible. One across leads #1 and #2, the other across leads #8 and #9.