

---

**Fire Alarm Control Panel**  
**NFS-640**  
**Installation Manual**

# Fire Alarm System Limitations

*While a fire alarm system may lower insurance rates, it is not a substitute for fire insurance!*

**An automatic fire alarm system**—typically made up of smoke detectors, heat detectors, manual pull stations, audible warning devices, and a fire alarm control panel with remote notification capability—can provide early warning of a developing fire. Such a system, however, does not assure protection against property damage or loss of life resulting from a fire.

The Manufacturer recommends that smoke and/or heat detectors be located throughout a protected premise following the recommendations of the current edition of the National Fire Protection Association Standard 72-1999 (NFPA 72-1999), manufacturer's recommendations, State and local codes, and the recommendations contained in the Guide for Proper Use of System Smoke Detectors, which is made available at no charge to all installing dealers. A study by the Federal Emergency Management Agency (an agency of the United States government) indicated that smoke detectors may not go off in as many as 35% of all fires. While fire alarm systems are designed to provide early warning against fire, they do not guarantee warning or protection against fire. A fire alarm system may not provide timely or adequate warning, or simply may not function, for a variety of reasons:

**Smoke detectors** may not sense fire where smoke cannot reach the detectors such as in chimneys, in or behind walls, on roofs, or on the other side of closed doors. Smoke detectors also may not sense a fire on another level or floor of a building. A second-floor detector, for example, may not sense a first-floor or basement fire.

**Particles of combustion or "smoke"** from a developing fire may not reach the sensing chambers of smoke detectors because:

- Barriers such as closed or partially closed doors, walls, or chimneys may inhibit particle or smoke flow.
- Smoke particles may become "cold," stratify, and not reach the ceiling or upper walls where detectors are located.
- Smoke particles may be blown away from detectors by air outlets.
- Smoke particles may be drawn into air returns before reaching the detector.

The amount of "smoke" present may be insufficient to alarm smoke detectors. Smoke detectors are designed to alarm at various levels of smoke density. If such density levels are not created by a developing fire at the location of detectors, the detectors will not go into alarm.

Smoke detectors, even when working properly, have sensing limitations. Detectors that have photoelectronic sensing chambers tend to detect smoldering fires better than flaming fires, which have little visible smoke. Detectors that have ionizing-type sensing chambers tend to detect fast-flaming fires better than smoldering fires. Because fires develop in different ways and are often unpredictable in their growth, neither type of detector is necessarily best and a given type of detector may not provide adequate warning of a fire.

Smoke detectors cannot be expected to provide adequate warning of fires caused by arson, children playing with matches (especially in bedrooms), smoking in bed, and violent explosions (caused by escaping gas, improper storage of flammable materials, etc.).

**Heat detectors** do not sense particles of combustion and alarm only when heat on their sensors increases at a predetermined rate or reaches a predetermined level. Rate-of-rise heat detectors may be subject to reduced sensitivity over time. For this reason, the rate-of-rise feature of each detector should be tested at least once per year by a qualified fire protection specialist. Heat detectors are designed to protect property, not life.

**IMPORTANT! Smoke detectors** must be installed in the same room as the control panel and in rooms used by the system for the connection of alarm transmission wiring, communications, signaling, and/or power. If detectors are not so located, a developing fire may damage the alarm system, crippling its ability to report a fire.

**Audible warning devices** such as bells may not alert people if these devices are located on the other side of closed or partly open doors or are located on another floor of a building. Any warning device may fail to alert people with a disability or those who have recently consumed drugs, alcohol or medication. Please note that:

- Strobes can, under certain circumstances, cause seizures in people with conditions such as epilepsy.
- Studies have shown that certain people, even when they hear a fire alarm signal, do not respond or comprehend the meaning of the signal. It is the property owner's responsibility to conduct fire drills and other training exercise to make people aware of fire alarm signals and instruct them on the proper reaction to alarm signals.
- In rare instances, the sounding of a warning device can cause temporary or permanent hearing loss.

**A fire alarm system** will not operate without any electrical power. If AC power fails, the system will operate from standby batteries only for a specified time and only if the batteries have been properly maintained and replaced regularly.

**Equipment used in the system** may not be technically compatible with the control panel. It is essential to use only equipment listed for service with your control panel.

**Telephone lines** needed to transmit alarm signals from a premise to a central monitoring station may be out of service or temporarily disabled. For added protection against telephone line failure, backup radio transmission systems are recommended.

**The most common cause** of fire alarm malfunction is inadequate maintenance. To keep the entire fire alarm system in excellent working order, ongoing maintenance is required per the manufacturer's recommendations, and UL and NFPA standards. At a minimum, the requirements of Chapter 7 of NFPA 72-1999 shall be followed. Environments with large amounts of dust, dirt or high air velocity require more frequent maintenance. A maintenance agreement should be arranged through the local manufacturer's representative. Maintenance should be scheduled monthly or as required by National and/or local fire codes and should be performed by authorized professional fire alarm installers only. Adequate written records of all inspections should be kept.

# Installation Precautions

*Adherence to the following will aid in problem-free installation with long-term reliability:*

**WARNING - Several different sources of power can be connected to the fire alarm control panel.** Disconnect all sources of power before servicing. The control unit and associated equipment may be damaged by removing and/or inserting cards, modules, or interconnecting cables while the unit is energized. Do not attempt to install, service, or operate this unit until this manual is read and understood.

**CAUTION - System Reacceptance Test after Software Changes.** To ensure proper system operation, this product must be tested in accordance with NFPA 72-1999 Chapter 7 after any programming operation or change in site-specific software. Reacceptance testing is required after any change, addition or deletion of system components, or after any modification, repair or adjustment to system hardware or wiring.

All components, circuits, system operations, or software functions known to be affected by a change must be 100% tested. In addition, to ensure that other operations are not inadvertently affected, at least 10% of initiating devices that are not directly affected by the change, up to a maximum of 50 devices, must also be tested and proper system operation verified.

**This system** meets NFPA requirements for operation at 0°C to 49°C (32°F to 120°F) and at a relative humidity (noncondensing) of 85% at 30°C (86°F) per NFPA, and 93% ± 2% at 32°C ± 2°C (89.6°F ± 1.1°F) per ULC. However, the useful life of the system's standby batteries and the electronic components may be adversely affected by extreme temperature ranges and humidity. Therefore, it is recommended that this system and all peripherals be installed in an environment with a nominal room temperature of 15-27° C/60-80° F.

**Verify that wire sizes are adequate** for all initiating and indicating device loops. Most devices cannot tolerate more than a 10% I.R. drop from the specified device voltage.

**Like all solid state electronic devices,** this system may operate erratically or can be damaged when subjected to lightning-induced transients. Although no system is completely immune from lightning transients and interferences, proper grounding will reduce susceptibility. Overhead or outside aerial wiring is not recommended, due to an increased susceptibility to nearby lightning strikes. Consult with the Technical Services Department if any problems are anticipated or encountered.

**Disconnect AC power and batteries** prior to removing or inserting circuit boards. Failure to do so can damage circuits.

**Remove all electronic assemblies** prior to any drilling, filing, reaming, or punching of the enclosure. When possible, make all cable entries from the sides or rear. Before making modifications, verify that they will not interfere with battery, transformer, and printed circuit board location.

**Do not tighten screw terminals** more than 9 in-lbs. Over-tightening may damage threads, resulting in reduced terminal contact pressure and difficulty with screw terminal removal.

**Though designed to last many years,** system components can fail at any time. This system contains static-sensitive components. Always ground yourself with a proper wrist strap before handling any circuits so that static charges are removed from the body. Use static-suppressive packaging to protect electronic assemblies removed from the unit.

**Follow the instructions** in the installation, operating, and programming manuals. These instructions must be followed to avoid damage to the control panel and associated equipment. FACP operation and reliability depend upon proper installation by authorized personnel.

Precau-L-10-2003.fm

## FCC Warning

**WARNING:** This equipment generates, uses, and can radiate radio frequency energy and if not installed and used in accordance with the instruction manual, may cause interference to radio communications. It has been tested and found to comply with the limits for class A computing device pursuant to Subpart B of Part 15 of FCC Rules, which is designed to provide reasonable protection against such interference when operated in a commercial environment. Operation of this equipment in a residential area is likely to cause interference, in which case the user will be required to correct the interference at his own expense.

## Canadian Requirements

This digital apparatus does not exceed the Class A limits for radiation noise emissions from digital apparatus set out in the Radio Interference Regulations of the Canadian Department of Communications.

Le present appareil numerique n'emet pas de bruits radioelectriques depassant les limites applicables aux appareils numeriques de la classe A prescrites dans le Reglement sur le brouillage radioelectrique edicte par le ministere des Communications du Canada.

Acclimate Plus™, AWACS™, HARSH™, NOTI-FIRE-NET™, ONYX™, and VeriFire™ are trademarks, and FlashScan®, UniNet®, and VIEW® are registered trademarks of NOTIFIER. NION™ is a trademark of NIS. NIS™ and Notifier Integrated Systems™ are trademarks and NOTIFIER® is a registered trademark of Fire-Lite Alarms, Inc. Echelon® is a registered trademark and LonWorks™ is a trademark of Echelon Corporation. ARCNET® is a registered trademark of Datapoint Corporation. Microsoft® and Windows® are registered trademarks of the Microsoft Corporation. LEXAN® is a registered trademark of GE Plastics, a subsidiary of General Electric Company.

# Documentation Feedback

Your feedback helps us keep our documentation up-to-date and accurate. If you have any comments or suggestions about our online Help or printed manuals, you can email us.

Please include the following information:

- Product name and version number (if applicable)
- Printed manual or online Help
- Topic Title (for online Help)
- Page number (for printed manual)
- Brief description of content you think should be improved or corrected
- Your suggestion for how to correct/improve documentation

Send email messages to:

**[TechPubs@fla-whq.com](mailto:TechPubs@fla-whq.com)**

Please note this email address is for documentation feedback only. If you have any technical issues, please contact Technical Services.

# Table of Contents

<b>Section 1 About This Manual</b> .....	<b>7</b>
1.1 Standards and Other Documents .....	7
1.2 Supplemental Documentation .....	8
<b>Section 2 System Overview</b> .....	<b>11</b>
2.1 System Description .....	11
2.1.1 Standard Features .....	11
2.1.2 Options .....	12
2.1.3 System Limitations .....	12
2.2 System Components .....	12
2.2.1 Basic Equipment Required .....	12
2.2.2 Control Panel Circuit Board .....	13
2.2.3 Main Power Supply .....	13
2.2.4 Circuit Board Components .....	14
2.3 System Cabinets .....	16
2.4 Optional Devices .....	17
2.5 Intelligent Detectors .....	18
2.6 Addressable Modules .....	19
2.7 Annunciation Modules .....	21
2.8 Annunciators .....	21
2.8.1 Annunciators with 24- and 48-Point Capacity .....	21
2.8.2 Annunciators with 16- and 32-Point Capacity .....	22
2.8.3 Annunciator Fixed Modules .....	22
2.9 Peripheral Displays and Printers .....	23
2.10 Panel Circuit Modules .....	24
2.11 Voice Alarm System .....	25
<b>Section 3 Installation</b> .....	<b>27</b>
3.1 Preparing for Installation .....	27
3.1.1 Standards and Codes .....	27
3.2 Installation Checklist .....	28
3.3 Mounting a Cabinet .....	29
3.4 Laying Out Equipment in Cabinet and Chassis .....	30
3.5 Installing the Control Panel .....	31
3.5.1 Control Panel Circuit Board & Keypad/Display Unit .....	31
3.5.2 Using NCA as Primary Display .....	33
3.5.3 Loop Expander Module .....	34
3.5.4 Network Control Module .....	35
3.5.5 Panel Circuit Modules and Other Option Boards .....	35
3.5.6 Overview .....	37
3.5.7 Connecting the Control Panel to AC Power .....	37
3.5.8 Checking AC Power .....	38
3.5.9 Installing and Connecting the Batteries .....	38
3.5.10 APS-6R Auxiliary Power Supply Connections .....	39
3.5.11 External DC Power Output Connections .....	39
3.5.12 NAC Connections & Releasing Circuits .....	40
3.5.13 Output Relay Connections .....	40
3.5.14 Backup-Alarm Switches .....	41
3.5.15 Installing a Transmitter Module TM-4 .....	41
3.6 UL Power-limited Wiring Requirements .....	42
3.6.1 Labeling Modules and Circuits .....	42
3.7 Installing Panel Circuit Modules .....	43
3.7.1 Overview .....	43
3.7.2 Mounting Expander Boards .....	43
3.7.3 Connecting Ribbon Cables for a CAB-4 Series Backbox .....	44
3.7.4 Installing the Panel Circuit Modules .....	44
3.7.5 Connecting ICM-4RK and ICE-4 Modules .....	45
3.7.6 Field-Wiring the ICM-4RK and ICE-4 (NFPA Style Y or Z) .....	46
3.7.7 Connecting CRM-4RK/CRE-4 Modules .....	47
3.8 Auxiliary Relay Module (ARM-4): Product-Specific Details .....	48

3.8.1 Overview .....	48
3.8.2 Installation .....	48
3.8.3 Field Wiring an Auxiliary Relay Module .....	49
3.9 Installing Remote Printers and/or CRT .....	50
3.9.1 Custom Cable Fabrication .....	50
3.9.2 Installing and Configuring the PRN-5 Printer .....	50
3.9.3 Installing and Configuring a Keltron Printer .....	51
3.9.4 Installing and Configuring a CRT-2 .....	52
3.9.5 Connecting a PC .....	54
3.9.6 Connecting Multiple Printers, CRTs, or CRT/PRN Combination .....	55
3.10 Wiring a Signaling Line Circuit (SLC) .....	56
<b>Section 4 Applications .....</b>	<b>57</b>
4.1 Overview .....	57
4.2 NFPA 72-1999 Central or Remote Station Fire Alarm System (Protected Premises Unit) .....	58
4.3 NFPA 72-1999 Proprietary Fire Alarm Systems .....	59
4.4 Fire/Security Applications .....	59
4.4.1 General Operation .....	59
4.4.2 Installing a Security Tamper Switch .....	60
4.4.3 Receiving Unit .....	60
4.4.4 Programming .....	61
4.4.5 Wiring for Proprietary Security Alarm Applications .....	62
4.5 Releasing Applications .....	63
4.5.1 Overview .....	63
4.5.2 Programming .....	63
4.5.3 Wiring .....	64
4.5.4 Connecting a Releasing Device to the Control Panel .....	64
4.5.5 Connecting a Releasing Device to the FCM-1 Module .....	65
4.5.6 Connecting an NBG-12LRA Agent Release-Abort Station .....	66
<b>Section 5 Testing the System .....</b>	<b>67</b>
5.1 Acceptance Test .....	67
5.2 Periodic Testing and Service .....	67
5.3 Operational Checks .....	67
5.4 Battery Checks and Maintenance .....	68
<b>Appendix A Power Supply Calculations .....</b>	<b>69</b>
A.1 Calculating AC Branch Circuit Current .....	69
A.2 Calculating the System Current Draws .....	69
A.2.1 Calculating the Maximum Secondary Power Fire Alarm Current Draw .....	72
A.3 Calculating the Battery Requirements .....	73
A.3.1 Calculating the Battery Capacity .....	73
A.3.2 Calculating the Battery Size .....	74
<b>Appendix B Electrical Specifications .....</b>	<b>75</b>
B.1 Electrical Specifications .....	75
B.2 Wire Requirements .....	77
<b>Appendix C Compatible Equipment.....</b>	<b>79</b>
C.1 UL-Listed Equipment .....	79
C.2 US Coast Guard & Lloyd's Register .....	81
<b>Appendix D Canadian Applications.....</b>	<b>83</b>
D.1 Standalone Application .....	83
D.1.1 NFS-640 with KDM-2 .....	83
D.1.2 NFS-640 with NCA .....	83
D.2 Local Network Application .....	83
D.3 Automatic Alarm Signal Silence .....	83
D.4 Annunciator Applications .....	83
D.5 Releasing Devices .....	83
<b>Index .....</b>	<b>85</b>

# Section 1 About This Manual

## 1.1 Standards and Other Documents

This Fire Alarm Control Panel complies with the following NFPA standards:



NFPA 12 CO<sub>2</sub> Extinguishing Systems  
NFPA 12A Halon 1301 Extinguishing Systems  
NFPA 13 Sprinkler Systems  
NFPA 15 Water Spray Systems  
NFPA 16 Foam/Water Deluge and Foam/Water Spray Systems  
NFPA 17 Dry Chemical Extinguishing Systems  
NFPA 17A Wet Chemical Extinguishing Systems  
NFPA 72-1999 Central Station Fire Alarm Systems (Automatic, Manual and Waterflow) Protected Premises Unit (requires Notifier UDACT).  
NFPA 72-1999 Local (Automatic, Manual, Waterflow and Sprinkler Supervisory) Fire Alarm Systems.  
NFPA 72-1999 Auxiliary (Automatic, Manual and Waterflow) Fire Alarm Systems (requires TM-4).  
NFPA 72-1999 Remote Station (Automatic, Manual and Waterflow) Fire Alarm Systems  
NFPA 72-1999 Proprietary (Automatic, Manual and Waterflow) Fire Alarm Systems (Protected Premises Unit).  
NFPA 2001 Clean Agent Fire Extinguishing Systems

### The installer should be familiar with the following documents and standards:

NFPA 72-1999 Initiating Devices for Fire Alarm Systems  
NFPA 72-1999 Inspection, Testing and Maintenance for Fire Alarm Systems  
NFPA 72-1999 Notification Appliances for Fire Alarm Systems



**Underwriters Laboratories**  
UL 38 Manually Actuated Signaling Boxes  
UL 217 Smoke Detectors, Single and Multiple Station  
UL 228 Door Closers - Holders for Fire Protective Signaling Systems  
UL 268 Smoke Detectors for Fire Protective Signaling Systems  
UL 268A Smoke Detectors for Duct Applications  
UL 346 Waterflow Indicators for Fire Protective Signaling Systems  
UL 464 Audible Signaling Appliances  
UL 521 Heat Detectors for Fire Protective Signaling Systems  
UL 864 Standard for Control Units for Fire Protective Signaling Systems  
UL 1481 Power Supplies for Fire Protective Signaling Systems  
UL 1971 Visual Signaling Appliances  
UL 1076 Proprietary Burglar Alarm Systems



**Underwriters Laboratories of Canada (ULC)**  
Standard CAN/ULC-S527-M99  
CAN/ULC-S524-M91 Standard for the Installation of Fire Alarm Systems

**Other**  
EIA-485 and EIA-232 Serial Interface Standards  
NEC Article 300 Wiring Methods  
NEC Article 760 Fire Protective Signaling Systems  
Applicable Local and State Building Codes  
Requirements of the Local Authority Having Jurisdiction  
C22.1-98 The Canadian Electrical Code, Part 1

## 1.2 Supplemental Documentation

The table below provides a list of documents referenced in this manual, as well as documents for selected other compatible devices. The document series chart (DOC-NOT) provides the current document revision. A copy of this document is included in every shipment.

**Table 1 Reference Documentation (Sheet 1 of 2)**

<b>Compatible Conventional Devices (Non-addressable)</b>	<b>Document Number</b>
Device Compatibility Document	15378
<b>Fire Alarm Control Panel (FACP) and Main Power Supply Installation</b>	<b>Document Number</b>
NFS-640 Installation, Operations, and Programming Manuals	51332, 51334, 51333
Voice Alarm System Manual	51252
SLC Wiring Manual	51253
Note: For individual SLC Devices, refer to the <i>SLC Wiring Manual</i>	
<b>Off-line Programming Utility</b>	<b>Document Number</b>
VeriFire™ Tools CD help file	VERIFIRE-TCD
<b>Cabinets &amp; Chassis</b>	<b>Document Number</b>
CAB-3/CAB-4 Series Cabinet Installation Document	15330
Battery/Peripherals Enclosure Installation Document	50295
<b>Power Supplies, Auxiliary Power Supplies &amp; Battery Chargers</b>	<b>Document Number</b>
ACPS-2406 Installation Manual	51304
APS-6R Instruction Manual	50702
CHG-120 Battery Charger Manual	50641
FCPS-24 Field Charger/Power Supply Manual	50059
<b>Networking</b>	<b>Document Number</b>
Noti•Fire•Net Manual, Network Version 4.0 & Higher	51584
NCM-W/F Installation Document	51533
NCS Network Control Station Manual, Network Version 4.0 & Higher	51658
<b>System Components</b>	<b>Document Number</b>
Annunciator Control System Manual	15842
Annunciator Fixed Module Manual	15048
AFM-16A Annunciator Fixed Module Manual	15207
ACM-8R Annunciator Control Module Manual	15342
LCD-80 Manual	15037
LCD-80TM Manual	51082
LDM Series Lamp Driver Annunciator Manual	15885
NCA Network Control Annunciator Manual	51482
SCS Smoke Control Manual (Smoke and HVAC Control Station)	15712
DPI-232 Direct Panel Interface Manual	51499
TM-4 Installation Document (Reverse Polarity Transmitter)	51490
UDACT Manual (Universal Digital Alarm Communicator/Transmitter)	50050
ACT-2 Installation Document	51118
VEC 25/50 Manual	50686
RM-1 Series Remote Microphone Installation Document	51138



**Table 1 Reference Documentation (Sheet 2 of 2)**

RA400Z Remote LED Annunciator Installation Document	I56-508
RFX Wireless Interface Manual	51012
UZC-256 Universal Zone Coder Manual	15216
UZC-256 Programming Manual	15976
XP Transponder Manual	15888
XP10-M Installation Document	I56-1803
XP5 Series Manual	50786
XP6-C Installation Document	I56-1805
XP6-MA Installation Document	I56-1806
XP6-R Installation Document	I56-1804
XPIQ Audio Transponder Manual	51013

## Cautions and Warnings

This manual contains cautions and warnings to alert the reader as follows:



**CAUTION:** Information about procedures that could cause programming errors, runtime errors, or equipment damage.



**WARNING:** Indicates information about procedures that could cause irreversible damage to the control panel, irreversible loss of programming data or personal injury.

## Notes

# Section 2 System Overview

## 2.1 System Description

The NFS-640(E) control panel is a modular, intelligent fire alarm control panel (FACP) with an extensive list of powerful features. The control panel integrates a central processing unit (CPU), a 6 amp power supply, and a battery charger. This is combined with a mounting chassis and cabinet to create a complete fire alarm control system. The panel supports FlashScan protocol and has network capabilities. A single SLC loop is supported with the basic equipment package; a second SLC loop can be added by attaching an optional loop expander module (LEM-320).

Modular devices mount to the chassis to provide additional output circuits, including voice and telephone modules to form a complete voice evacuation system. Five cabinet options for enclosing system components are available.

The control panel has the capacity for installing up to 636 addressable points; 159 detectors and 159 monitor/control modules per SLC (Signaling Line Circuit).

### 2.1.1 Standard Features

- Uses Notifier's VIEW® early warning fire detection and the FlashScan® or Classic Loop Interface Protocol (CLIP) families of detectors and modules
- Four standard Notification Appliance Circuits (NAC), Class A or B
- Alarm, Trouble, Supervisory and Security relays
- Support for 32 annunciator addresses, with 10 special annunciator groups
- Supports Style 4, Style 6, Style 7 SLC loops
- Connections to easily mount an expander board to add a second SLC loop
- Releasing service using on-board NACs or FCM-1 modules
- Logic Equations
- Display scroll selection
- Alarm verification supervisory indication (NYC)
- Supervisory duct detectors
- Supports Advanced Warning Addressable Combustion Sensing (AWACS) algorithms
- Network operation
- Battery charger supports 12-55 amp hour sealed lead-acid batteries
- EIA-485 connections for wiring ACS annunciators (including LDM custom graphic annunciators), TM-4 transmitter
- EIA-232 connections for printer, CRT, printer/CRT, or network operation
- Autoprogram feature for faster programming of new devices
- The control panel provides 6.0 amps of usable output power in an alarm condition; it provides 3.0 amps of usable output power in normal or continuous operating conditions
- Diagnostic LEDs and switches
- Ground fault detection
- Battery and battery-charger supervision, voltage-monitoring, and current-monitoring
- Panel circuit modules support up to 64 circuits
- Programmable for strobe synchronization

## 2.1.2 Options

Refer to Section 2.2 “System Components” for descriptions of the various optional modules.

- QWERTY silicone-rubber keypad with a 2x40 LCD display and eight indicator LEDs
- Optional LEM-320 provides a second SLC loop that is electrically identical to the one on the main board
- Optional devices include: UDACT Universal Digital Alarm Communicator/Transmitter, ACM-8R remote relay module to increase point capacity, audio and voice components, and panel circuit modules
- Optional LCD-80 connected through an EIA-485 interface allows monitoring the system—up to 6,000 feet (1829 meters) from the control panel

## 2.1.3 System Limitations

System expansion must take into consideration the following:

1. The physical limitations of the cabinet configuration.
2. The electrical limitations of the system power supply.
3. The capacity of the secondary power source (standby batteries).

## 2.2 System Components

### 2.2.1 Basic Equipment Required

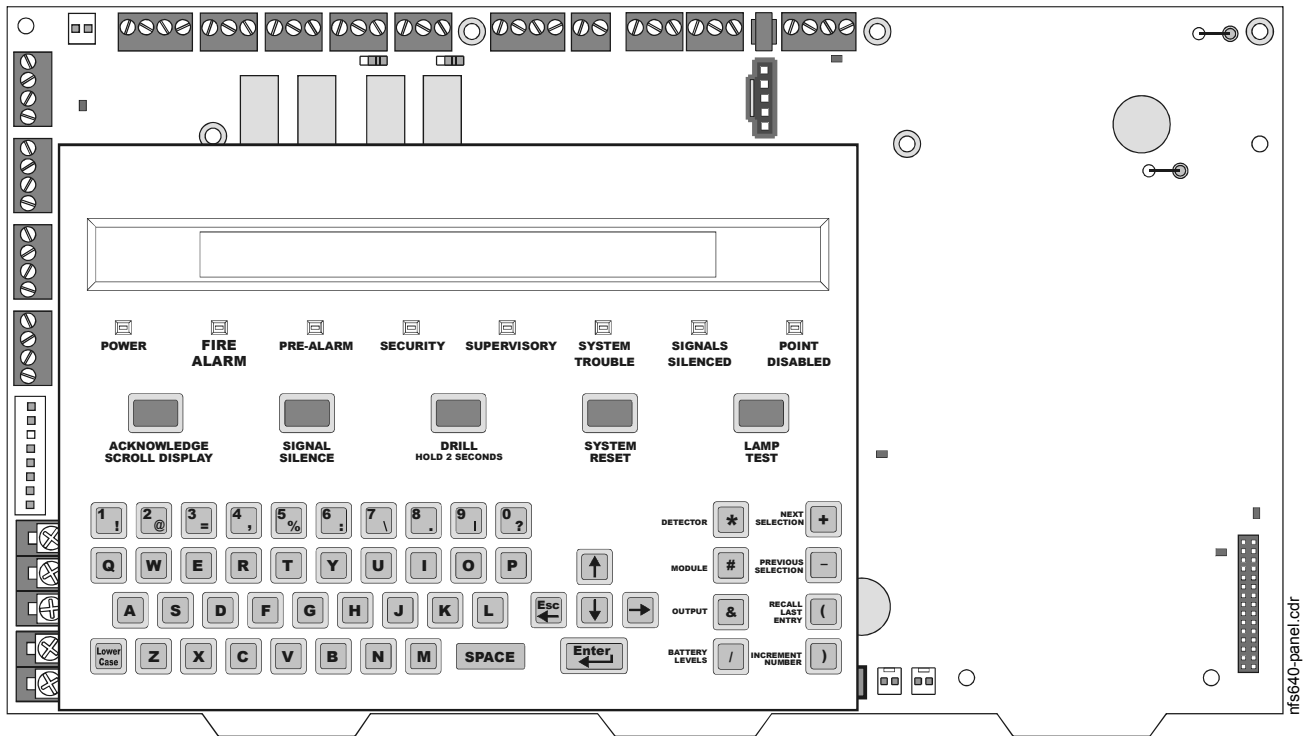
A basic NFS-640 system requires at least the following components:

1. The control panel. CPU-640 (120V operation) or CPU-640E (240V operation).  
This printed circuit board is the “control panel” itself and the heart of the system. It also includes an expander cable for connecting panel modules, a grounding cable, battery interconnect cables, and document kit.
2. One or more chassis. CHS-M2 mounts the CPU-640/CPU-640E.  
To mount additional rows of optional equipment, order one or more chassis from this list: CHS-M2, CHS-4N (included in shipkit CHS-4MB), CHS-4L.
3. A primary display. Generally this is a KDM-2 keypad/display, a DP-DISP dress panel, and two BMP-1 blank module panels. For information on using NCA as primary display instead of KDM-2, see Section 3.5.2 “Using NCA as Primary Display” and the *NCA Manual*.
4. A backbox and door:  
SBB-A4 and DR-A4 (one row of equipment) or  
SBB-B4 and DR-B4 (two rows of equipment) or  
SBB-C4 and DR-C4 (three rows of equipment) or  
SBB-D4 and DR-D4 (four rows of equipment)  
(For a solid-metal door add “B” to the part number; for a red door add “R”.)
5. A battery dress panel BP-4
6. Batteries (Refer to Appendix A.3 “Calculating the Battery Requirements” for system current-draw calculations; CAB-4 series backboxes holds batteries up to 24 AH maximum.)

## 2.2.2 Control Panel Circuit Board

The control panel electronics are contained on one four-layer printed circuit board (PCB) that incorporates a 6 amp power supply with battery charger, a signaling line circuit (SLC) and the central processing unit. A keypad/display unit can be installed over the power supply as shown Figure 1.

Figure 1 NFS-640 Control Panel with Optional Keypad/Display Unit Installed

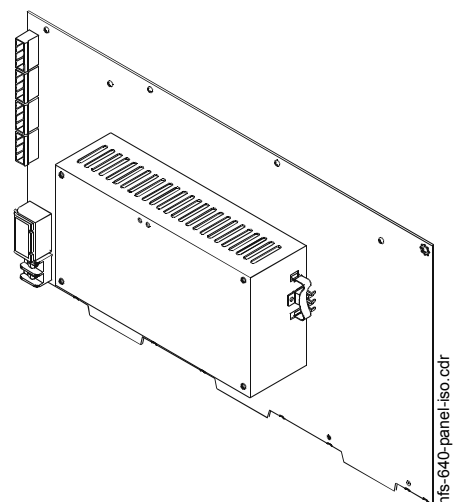


## 2.2.3 Main Power Supply

The main power supply is an integral part of the control panel's circuit board. It provides a total of 3 A (6 A in alarm) and contains an integral battery charger. This can be used for many functions including:

- Powering the NFS-640
- Powering a variety of UL-listed 24 VDC notification appliances from four built-in NAC outputs
- Providing up to 1.25 A of resettable power for four-wire smoke detectors
- Providing up to 1.25 A of non-resettable power for external devices such as the TM-4 Transmitter Module.

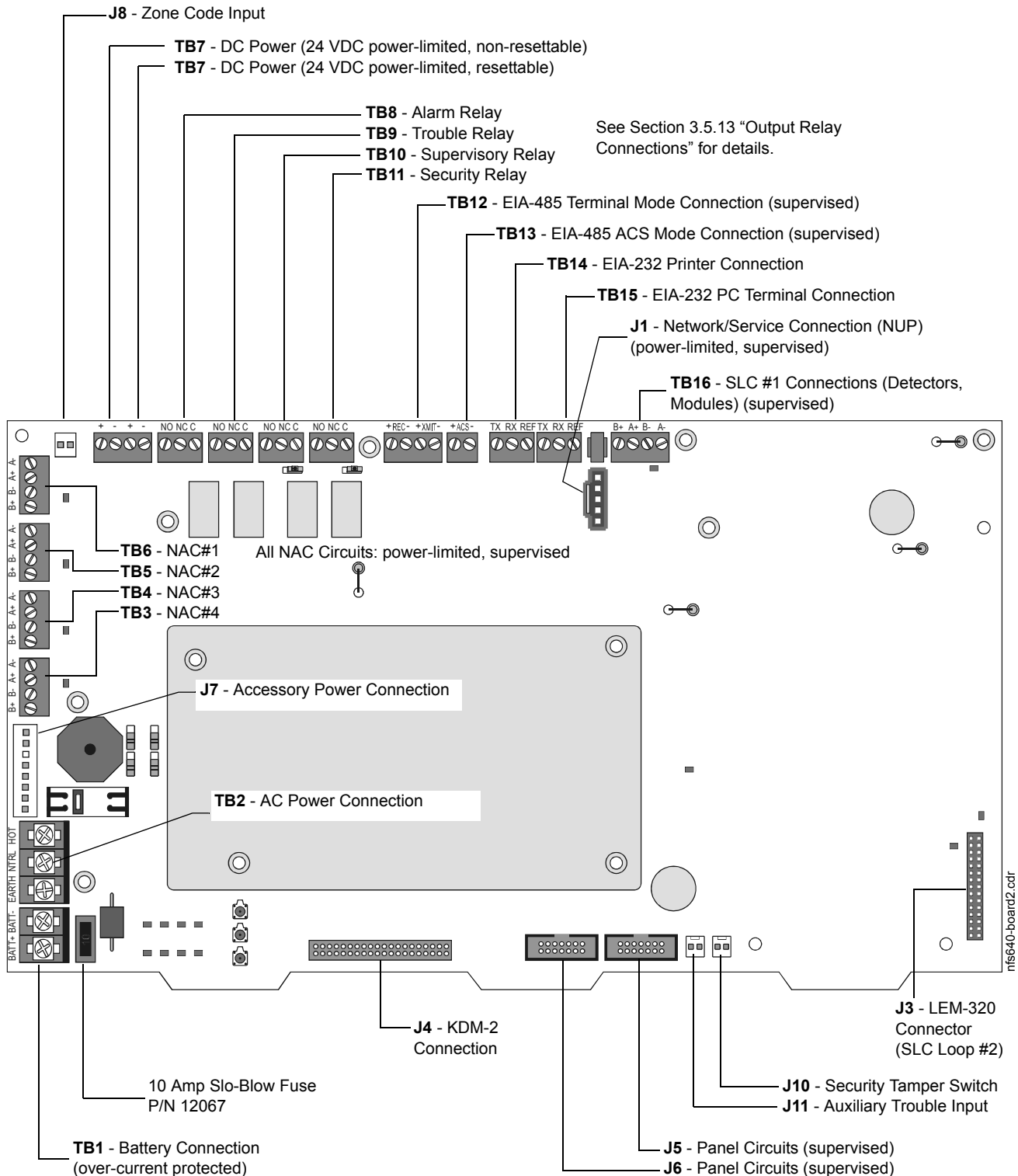
Figure 2 Main Power Supply on Control Panel



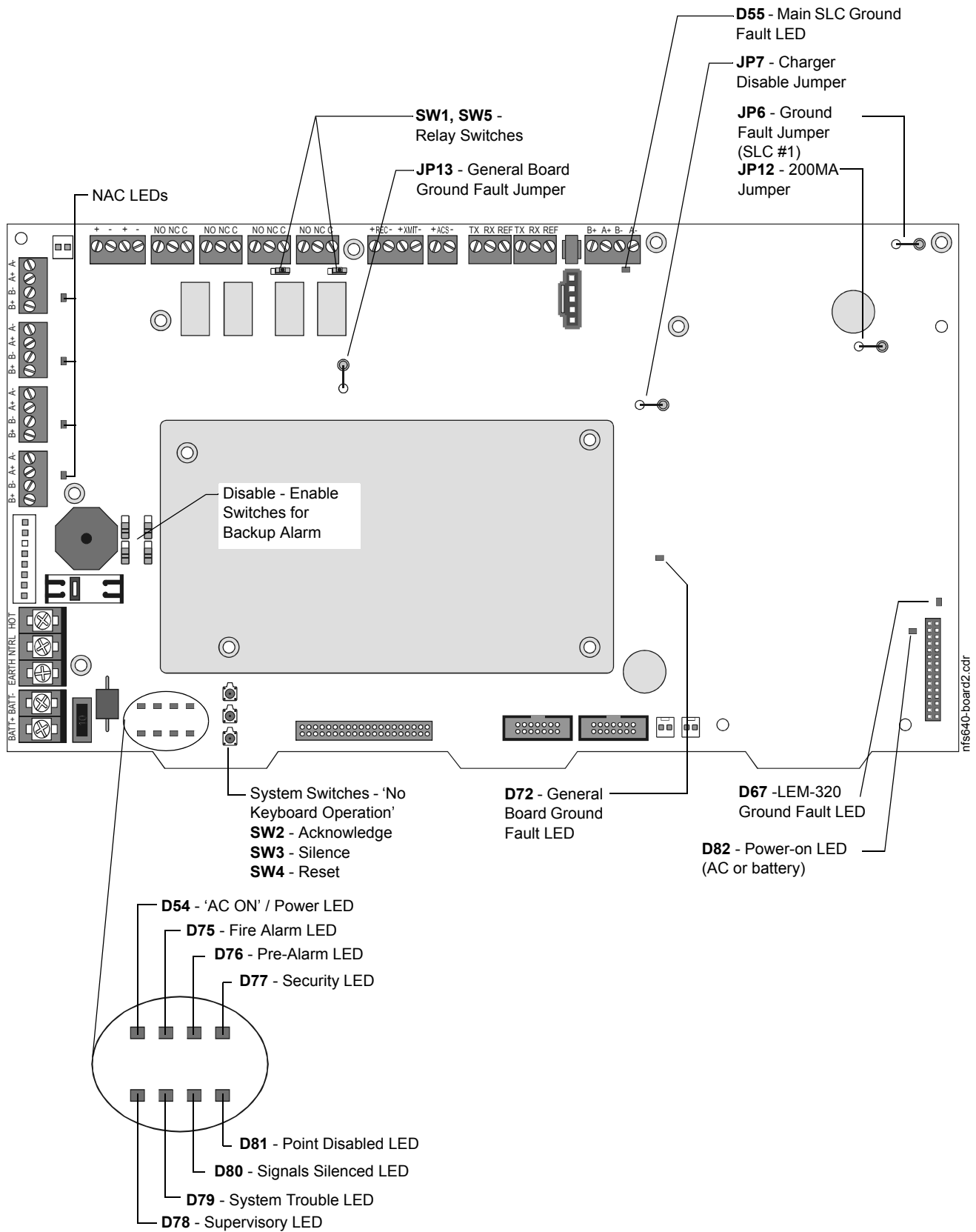
## 2.2.4 Circuit Board Components

The following two figures illustrate the location of the various connections, switches, jumpers and LEDs on the circuit board. Figure 3 shows wiring connections. Figure 4 shows jumpers, LEDs and switches. See Section 3 “Installation” for more details.

**Figure 3 Circuit Board Components: Wiring Connections**



**Figure 4 Circuit Board Components: Jumpers, LEDs and Switches**



## 2.3 System Cabinets

The control panel and modules are installed in a CAB-4 series backbox. There are four different sizes available, holding from one to four rows of equipment plus batteries (up to two 25AH batteries). Backboxes are ordered separately from doors. The doors can be mounted on the left or the right side of the cabinet; reversible hinges are provided so that this choice can be made in the field. Doors open a full 180 degrees and have locks. Mounting methods include surface-mounting or semi-flush mounting on a wall between 16 inch (406.4 mm) on-center studs. A trim ring option is available for semi-flush mounting.

External measurements for each cabinet size are provided below. Refer to *CAB-3/CAB-4 Series Cabinet Installation Document* (shipped with the cabinet) for specific mounting drawings and dimensions.

<b>A-size backbox (one row)</b>	24.125 in (612.78 mm) wide 20.125 in (511.18 mm) tall 5.218 in (132.54 mm) deep	<b>Optional trim ring TR-A4</b> Opening: 24.062 in (611.175 mm) wide; 20.062 in (508.813 mm) tall. Molding width: 1.375 in (34.925 mm)
<b>B-size backbox (two rows)</b>	24.125 in (612.78 mm) wide 28.625 in (727.08 mm) tall 5.218 in (132.54 mm) deep Optional trim ring TR-B4	<b>Optional trim ring TR-B4</b> Opening: 24.062 in (611.175 mm) wide; 28.562 in (725.475 mm) tall. Molding width: 1.375 in (34.925 mm)
<b>C-size backbox (three rows)</b>	24.125 in (612.78 mm) wide 37.250 in (946.15 mm) tall 5.218 in (132.54 mm) deep Optional trim ring TR-C4	<b>Optional trim ring TR-C4</b> Opening: 24.062 in (611.175 mm) wide; 37.187 in (944.55 mm) tall. Molding width: 1.375 in (34.925 mm)
<b>D-size backbox (four rows)</b>	24.125 in (612.78 mm) wide 45.875 in (1165.23 mm) tall 5.218 in (132.54 mm) deep Optional trim ring TR-D4	<b>Optional trim ring TR-D4</b> Opening: 24.062 in (611.175 mm) wide; 37.187 in (1163.625 mm) tall. Molding width: 1.375 in (34.925 mm)

The control panel and adjacent first-row modules mount in chassis CHS-M2, typically in the first/top row of the backbox. Additional rows of modules can be mounted in chassis CHS-4N and/or CHS-4L.

**Note:** If using the new CHS-M2 in a CAB-3 series backbox or in a CAB-4 series backbox manufactured before 11/2003, verify stud height and cut any stud that exceeds 0.375 in. (9.525 mm) if a CPU is being mounted above it. See warning and instructions in Section 3.5.1 “Control Panel Circuit Board & Keypad/Display Unit”.

Some additional components available in the CAB-4 series include:

<b>DP-DISP</b>	An Inner Dress Panel for covering the backbox area surrounding display panels and various modules (required for Canadian installations).  <b>Note:</b> For use with NCA, KDM-2, and primary displays.
<b>BMP-1</b>	Blank Module Plate for covering an unused dress-panel position. Provides another option for mounting modules such as TM-4, NCM-W, or NCM-F.
<b>BP-4</b>	Battery dress panel
<b>VP-2B or MP-1B (with DP-1B)</b>	For covering top row(s) of backbox if control panel is mounted in a lower row. MP-1B is also used to mount panel circuit modules.

**Note:** When using trim rings, mount backbox with at least 1 inch (2.54 cm) between wall surface and front of backbox, to allow door to open fully past the trim ring.



## 2.4 Optional Devices

Several optional components can be installed within the NFS-640 system. This list provides only a sample of common equipment; for a complete list of what is available, refer to Appendix C “Compatible Equipment” and for a list of conventional equipment, refer to the *Device Compatibility Chart*.

**Network Control Annunciator - NCA.** Provides a text-based, 24 VDC powered, display and control device for Noti•Fire•Net. It incorporates a large LCD display and a silicone-rubber QWERTY keypad. It will display all events from a Noti•Fire•Net system.

**Network Control Module - NCM-W/F.** The NCM is an interface between the panel and Noti•Fire•Net. It comes in two models: wire and fiber-optic cable. Refer to the *NCM-W/F Installation Document* for more information and installation instructions.

**Loop Expander Module - LEM-320.** The LEM plugs into the control panel, expanding the board’s function to control two Signaling Line Circuits (SLCs). Each NFS-640 can have one LEM. Refer to Section 3.5 “Installing the Control Panel” for installation instructions.

**Auxiliary Power Supply - APS-6R.** The optional Auxiliary Power Supply is a 150W cabinet-mounted power supply, designed to power devices that require filtered, non-resettable power, such as XP Transponder modules, NAC modules, and addressable Notifier appliance circuit modules. The APS-6R provides three 24 VDC output circuits (6 A total in alarm, 4 A continuous): two power-limited circuits (3 A each) and one non-power-limited circuit (6 A). Refer to the *APS-6R Instruction Manual* for further information and installation instructions.

**Addressable Charger/Power Supply - ACPS-2406.** The optional ACPS-2406 is an addressable loop-based power supply and battery charger. This cabinet-mounted unit provides four individually addressable Notification Appliance Circuits. In addition, each circuit can provide notification appliance synchronization without an additional module. The unit charges 7 to 25 AH batteries with full supervision. The ACPS-2406 provides up to four 24 VDC (filtered) output circuits (2.5 A max each, 5.0 A total continuous, 6.0 A during a fire alarm). Refer to the *ACPS-2406 Instruction Manual* for further information, installation instructions, and battery calculations.

**Batteries and Battery Boxes.** The control panel uses only sealed lead-acid batteries for standby power. Maximum battery capacity is 55 AH (ampere-hour). Minimum battery capacity depends upon your system configuration; absolute minimum is 12 AH. CAB-4 Series backboxes provide space for two 25 AH (or smaller) batteries. Use external battery boxes if your installation requires larger capacity batteries. Battery boxes mount directly below the main cabinet. Battery box model NFS-LBB holds batteries up to 55 AH. Refer to Section 4.2 “NFPA 72-1999 Central or Remote Station Fire Alarm System (Protected Premises Unit)” and Section A.3 “Calculating the Battery Requirements” for further information. See *Battery/Peripherals Enclosure* document for backbox measurements and installation instructions.

**Universal Digital Alarm Communicator/Transmitter (UDACT).** Transmits system status to UL-listed Central Station Receivers over a public switched telephone network. Mounting is in a CAB-4 Series backbox or remotely in the ABS-8R enclosure. The unit connects to the EIA-485 annunciator port and 24 VDC (nominal) power. Refer to the *UDACT Instruction Manual* for further information and installation instructions.

**Transmitter Module - TM-4.** The TM-4 includes three reverse polarity outputs and a Fire Municipal Box Trip in a single module. It provides a means for the FACP to control Alarm, Trouble, and Supervisory reverse polarity outputs (15mA, 24 VDC nominal) or a Fire Municipal Box Trip output. All output circuits are supervised. The Transmitter Module communicates over the standard EIA-485 connection like an ACS device and mounts easily in standard module locations within the cabinet or external boxes. Refer to the *Transmitter Module TM-4* installation document for further information and installation instructions.

**Universal Zone Coder - UZC-256.** A circuit board, used for NAC coding applications, that provides three NAC output circuits and up to 256 zone codes. Refer to the *UZC-256 Universal*

*Zone Coder* and *UZC-256 Programming* manuals for further information and installation instructions.

**Field Charger/Power Supply - FCPS-24.** A compact, cost-effective remote power supply and battery charger. It consists of a filtered, 24 VDC output that can drive up to four Notification Appliance Circuits (NACs). Refer to the *FCPS-24 Field Charger/Power Supply* manual for further information and installation instructions.

**Battery Charger - CHG-120.** Designed to charge lead-acid batteries that provide emergency standby power for a Fire Alarm Control Panel. Provides two (2) output circuits for connection to multiple loads. Can be mounted into the CAB-4 Series backbox or the NFS-LBB Battery Box. Refer to the *CHG-120 Battery Charger* manual for further information and installation instructions.

**Liquid Crystal Display - LCD-80.** An alphanumeric display module that is an ancillary device which has two basic modes of operation. In *Terminal Mode* it acts as a display interface and in *ACS Mode* as an alphanumeric annunciator. The **LCD-80TM** is also available and provides *Terminal Mode* only. Refer to the *LCD-80* or *LCD-80TM Liquid Crystal Display* manuals for further information and installation instructions.

**SCS-8 Series Smoke Control System.** The Smoke Control Station (SCS-8) module uses eight groups of four annunciator points for fan shutdown control or other heating, ventilation or air conditioning functions. The Smoke Control Expander (SCE-8) is used to expand the SCS-8 by an additional eight groups of four annunciator points. Only one expander can be used per SCS-8. The Smoke Control Lamp Driver Station (SCS-8L) module uses eight groups of four annunciator points for fan shutdown control or other heating, ventilation or air conditioning functions. Must be mounted in custom graphic annunciator panel. The Smoke Control Expander (SCE-8L) is used to expand the SCS-8L by an additional eight groups of four annunciator points. Only one expander can be used per SCS-8L. Must be mounted in custom graphic annunciator panel. For more details on the SCS Smoke Control System, refer to the *SCS Manual*.

## 2.5 Intelligent Detectors

### Introduction

Intelligent, addressable detectors provide analog information to the control panel on a Signaling Line Circuit (SLC). This allows the control panel to continually process this information to determine the status (alarm, trouble, maintenance, or normal) of each detector. Each detector responds to an SLC address that is set in the detector head using built-in rotary switches. Each SLC loop can support up to 159 detectors. The sensitivity of each intelligent detector can be programmed (refer to Appendix C in the *NFS-640 Programming Manual* for details).

**Note:** A blinking LED on an intelligent detector indicates communication between the detector and the control panel.

### Detectors

The **FlashScan®** algorithm provides high-speed communication between analog intelligent devices, by polling in groups unless new information is reported. If one of the devices within the group has new information, the control panel stops the group poll and concentrates on single points. CLIP (Classic Loop Interface Protocol) is standard polling of each intelligent devices.

**FAPT-851 (Acclimate Plus™).** Intelligent detector that combines a photoelectric sensing chamber and fixed temperature heat detection (135°F (57.2°C)). FlashScan capable.

**FSI-851.** Addressable, intelligent smoke detector that incorporates an ionization sensing chamber. Designed to provide open area protection. FlashScan capable.

**FSP-851.** Analog, addressable intelligent smoke detector that uses a photoelectric sensing chamber. Listed for use in ducts. Designed to provide open area protection. FlashScan capable. The **FSP-851T** adds thermal sensors that will alarm at a fixed temperature of 135° F.

**FST-851.** Intelligent thermistor sensing circuit for fast response. Designed to provide open area protection with 50 foot spacing capability. A fixed temperature sensor with 135°F fixed temperature alarm. FlashScan capable. The **FST-851R** incorporates a thermal rate of rise of 15°F (9.4°C). FlashScan capable. The **FST-851H** is a high temperature sensor with 190°F fixed temperature alarm.

**FSI-751.** Analog, addressable, low profile intelligent smoke detector that incorporates an ionization sensing chamber. Designed to provide open area protection.

**FSP-751.** Same as FSI-751, but uses a photoelectric sensing chamber. The **FSP-751T** adds thermal sensors that will alarm at a fixed temperature of 135°F (57°C). Designed to provide open area protection.

**FST-751.** Intelligent thermistor sensing circuit for fast response. Designed to provide open area protection with 50 foot (15.24 m) spacing capability. The **FST-751R** incorporates a thermal rate of rise of 15°F (9.4°C).

**FSD-751P.** Photoelectric Duct Detector. The **FSD-751RP** includes an alarm relay. The **FSD-751PL** and **FSD-751RPL** are low-flow detectors.

**HPX-751 (HARSH™).** A special smoke detector that provides early warning smoke detection in hostile environments where traditional smoke detectors are not practical. CLIP mode only.

**FSH-751 (HARSH™).** A special smoke detector that provides early warning smoke detection in hostile environments where traditional smoke detectors are not practical. FlashScan capable.

**IPX-751.** A microprocessor-based intelligent smoke detector that uses a combination of photoelectric, ionization, and thermal sensing technologies. CLIP mode only.

**FAPT-751** Acclimate Plus™ is a Combination Photoelectric/Heat Detector. This intelligent, addressable, multi-sensing, low-profile detector can automatically adjust its sensitivity. It uses a combination of photoelectric and thermal sensing technologies that are designed to increase immunity to false alarms.

**LPX-751.** Early detection laser detector, similar to the FSL-751 VIEW®, but limited to CLIP mode operation only.

**FSL-751 VIEW® Low Profile Laser Detector.** An advanced intelligent photoelectric detector that uses a laser diode, special optics, and signal processing to obtain extremely high sensitivity. FlashScan capable.

## Bases

Several bases, to which the detectors are affixed, are available:

**B710LP.** Standard U.S. Low-Profile base

**B501.** Standard European flangeless base

**B501BH, B501BHT.** Sounder base, includes B501 Sounder base with temporal sounder

**B224RB.** Low Profile Intelligent relay base

**B224BI.** Low Profile Intelligent isolator base

**B710HD.** HARSH™ base.

## Accessories

**RA400Z.** A Remote Single LED Annunciator that can be wired directly off of an addressable detector for annunciation of that detector's alarm status.

## 2.6 Addressable Modules

Control Modules and Monitor Modules provide an interface between the control panel and conventional notification and initiating devices. Each module can be set to respond to an address

with built-in rotary switches with the ability to select up to 159 addresses. An LED will blink on a monitor module to indicate communication between the module and the control panel.

**Note:** For a list of approved notification and initiating devices, refer to the *Device Compatibility Document*.

**Monitor Modules - FMM-1, FZM-1 & FDM-1.** Addressable monitor modules for monitoring conventional initiating devices. The FMM-1 is used for normally open contact alarm initiating devices, such as manual pull stations, four-wire smoke detectors, heat detectors, waterflow, and supervisory devices. Use the FZM-1 for interface to two-wire smoke detectors in addition to normally open contacts. The FDM-1 provides two independent 2-wire Initiating Device Circuits (IDCs) at two separate, consecutive addresses. Wire supervised IDCs as NFPA Style B (Class B) or Style D (Class A) circuits. The modules come with a thermoplastic cover for mounting to a 4-inch (10.16 cm) square mounting box.

**Monitor Module - FMM-101.** An addressable module that is functionally similar to the FMM-1 Monitor Module—but offered in a smaller package for mounting directly in the electrical box of the device being monitored. (Class B input circuit only.)

**Control Module, NAC - FCM-1.** Addressable Control Module used as Notification Appliance Circuits (NACs) to power and supervise compatible, UL-listed notification appliances. Wired supervised NACs as NFPA Style Y (Class B) or Style Z (Class A). The modules come with a thermoplastic cover for mounting to a 4-inch (10.16 cm) square mounting box.

**Control Module, Relay - FRM-1.** Similar to the FCM-1 except used as a Form-C control relay module.

**Fault Isolator Module - ISO-X.** This module is not addressable, but listed here due to its use in an SLC. Protects the system against wire-to-wire short circuits on the SLC. It should be placed between groups of sensors in a Style 6 or Style 7 SLC to isolate short- and open-circuit problems and protect the rest of the loop so it can continue to operate normally.

**Pull Station - NBG-12LX.** An addressable manual pull station with key-lock reset feature. The addressable module is housed within the pull station.

**Transponder - XP5-M.** Supervises five Class-B addressable Initiating Device Circuits each with a maximum loop resistance of 1,200 ohms. These circuits monitor normally open contact initiating devices (manual pull stations, heat detectors, four-wire smoke detectors, security contacts, etc.). One XP5-M occupies five consecutive addresses on the signaling line circuit (SLC). Each circuit has one red LED status indicator that blinks when it is not active, and produces a steady glow when active. For more information see the *XP5 Series Transponder Manual*.

**Transponder - XP5-C.** Each of the five circuits of the XP5-C can act as a notification appliance/speaker/telephone circuit (Class B only) or a Form-C relay. A push-button switch changes the circuit to a Form-C relay. One XP5-C occupies five consecutive addresses on the SLC. Each circuit has one green LED status indicator that blinks when it is not active, and produces a steady glow when active. For more information see the *XP5 Series Transponder Manual*.

**Quad Intelligent Audio Transponder - XPIQ.** The XPIQ is an integrated audio amplification and distribution subsystem that can direct up to four low-level audio signals through four audio amplifiers to integrated, continuously supervised speaker circuits. An on-board power supply charges and supervises battery backup.

**Multi-Input/Output Modules - XP6-C, XP6-R, XP10-M, XP6-MA.** FlashScan capable multi-input/output modules are available for use on the SLC loop. All are FlashScan capable.

- XP6-C controls six NAC or speaker/telephone circuits. Applications are equivalent to those for XP5-C set as a notification appliance/speaker/telephone circuit.
- XP6-R controls six Form-C relays. Applications are equivalent to those for XP5-C set as a Form-C relay.
- XP10-M supervises ten Class-B addressable Initiating Device Circuits (IDC) which monitor normally open contact initiating devices. Applications are equivalent to those for XP5-M.

- XP6-MA enables an intelligent alarm system to monitor six zones of conventional two-wire detectors.

For installation instructions, refer to the documentation provided with the modules.

## 2.7 Annunciation Modules

### Introduction

This section contains brief descriptions and model numbers of annunciator modules that can be connected to the control panel. Communication between the control panel and annunciators takes place over a two-wire serial interface connected to the control panel's EIA-485 ACS Mode connection. Section 2.8 "Annunciators" contains more detailed information.

### Description

Below are descriptions of the Annunciator Modules and Expander Modules used with the control panel.

**Annunciator Control Module - ACM-8R.** Provides the control panel with a mappable relay control module. Relays can be selected for mapping anywhere in the system memory (in groups of eight). Provides eight Form-C relays with 5 A @ 125 VAC (resistive) or 5 A @ 30 VDC (resistive) or 2 A @ 125 VAC (inductive) contacts. Tracks any group of eight zones within the system.

Refer to *ACM-8R Annunciator Control Module* manual for more information.

**Lamp Driver Annunciator Module - LDM-32.** Provides 32 alarm lamp driver outputs for connection to a custom graphic annunciator. DIP switch selectable for 32 alarm outputs or 16 alarm/16 trouble outputs, and 16 switch inputs for control of system control functions as Signal Silence and System Reset.

Refer to the *LDM Series Lamp Driver Annunciator Modules* manual for more information.

**Lamp Driver Annunciator Expander Module - LDM-E32.** Expands the LDM-32 by 32 system points, to a maximum of 64 points.

**Lamp Driver Relay Expander Module - LDM-R32.** Provides the LDM-32 or LDM-E32 with 32 dry Form-A (normally open) contacts.

## 2.8 Annunciators

The Annunciator Control System provides the control panel with 32 remote annunciators. The number of points a particular annunciator can support is reflected in the part number. For example, an ACM-24AT has 24 points and an ACM-48A has 48 points. The number of points on an Annunciator Expander Module must match the number of points on the Annunciator Control Module it is expanding. One Annunciator Fixed Module can also be used per system. Connections are through an EIA-485 ACS Mode connection on the Control Panel.

**Note:** The NFS-640 can only support 64 points per annunciator address regardless of the model used.

Brief descriptions follow of specific modules used with the control panel. For detailed information, refer to the specified product manual.

### 2.8.1 Annunciators with 24- and 48-Point Capacity

For specific installation information, refer to the *Annunciator Control Module* manual. For Canadian requirements, see Appendix D "Canadian Applications".

**Annunciator Control Module - ACM-24AT.** A one-channel Class-B unit with 24 switch controlled annunciator points. Each point is controlled by a silicone-rubber switch with indicator LED. Multi-color LEDs can be programmed to produce one of three colors: red, green or yellow.

**Annunciator Expander Module - AEM-24AT.** An expander board for the ACM-24AT that provides an additional 24 points and is identical in size and appearance. Up to three expanders can be used with an ACM-24AT.

**Note:** An AEM-24AT cannot be used to expand an ACM-48A.

**Annunciator Control Module - ACM-48A.** A one-channel Class-B unit with 48 annunciator points for indicating current system status. Each annunciator point has a red LED for alarm, and a green LED for normal; each module has a yellow unit-trouble LED at the top.

**Annunciator Expander Module - AEM-48A.** An expander board for the ACM-48A that provides an additional 48 points and is identical in size and appearance. One expander can be used with an ACM-48A.

**Note:** An AEM-48A cannot be used to expand an ACM-24AT.

## 2.8.2 Annunciators with 16- and 32-Point Capacity

Models with several other LED color combinations are available for use in areas with specific color requirements. Refer to the *Annunciator Control System* manual for detailed information. For Canadian requirements, see Appendix D “Canadian Applications”.

**Annunciator Control Module - ACM-16AT.** Provides features for audible and visual indication of alarm and trouble conditions at each annunciator point. They include: 16 red alarm LEDs, 16 yellow trouble LEDs, 16 momentary touch-pad switches for controlling each point, System trouble LED, Online/Power LED, Local sounder, Silence/Acknowledge switch, and Remote functions.

**Annunciator Expander Module - AEM-16AT.** Expands the ACM-by 16 system points and is identical in size and appearance. Three expander modules are supported by one control module providing a maximum of 64 system points.

**Note:** An AEM-16AT cannot be used to expand an ACM-32A.

**Annunciator Control Module - ACM-32A.** Provides features for audible and visual indication of alarm and trouble conditions at each annunciator point. They include: 32 red alarm LEDs, System trouble LED, Online/Power LED, Local sounder, and Silence/Acknowledge switch.

**Annunciator Expander Module - AEM-32A.** Expands the ACM-32A by 32 system points and is identical in size and appearance. One expander module is supported by the control module providing a maximum of 64 system points.

**Note:** An AEM-32A cannot be used to expand an ACM-16AT.

## 2.8.3 Annunciator Fixed Modules

### Introduction

Provide the control panel with discrete display and control points. Fixed modules turn their LEDs on and off as directed by the control panel, and also report switch activations to the control panel for action. You can only use one fixed module in a system. Each annunciator's address is fixed at address 1.

Refer to the *Annunciator Fixed Module* manual for further information.

### Description

**Annunciator Fixed Module - AFM-16AT.** Contains 16 red alarm and 16 yellow trouble LEDs, a system trouble LED, an Online/Power LED, and a local sounder, and switches for control panel Acknowledge, Alarm Silence, and System Reset. Use the AFM-16AT for systems that require 16 or fewer annunciation points.

**Annunciator Fixed Module - AFM-32A.** Contains 32 red alarm LEDs, a system trouble LED, an ON LINE/POWER LED, and a local panel sounder with a silence/acknowledge switch. The AFM-32A is fixed at address 1, and will not accept expander modules.

## 2.9 Peripheral Displays and Printers

The control panel is compatible with the following printers and display devices:

- PRN-5 Printer
- Keltron Remote Printer VS4095
- CRT-2 Display Terminal

All EIA-232 devices must be located in the same room within 50 feet (15.24 m) of the control panel.

**Printer - PRN-5.** The PRN-5 is an optional printer that connects directly to the control panel through an EIA-232 interface (TB14) and can be located up to 50 feet (15.24 m) from the control panel. It creates a printed record (80 columns of data on standard 9" x 11" tractor-feed paper) of all system events (alarm, trouble) and status changes within the system. The printout is time-stamped with the current time-of-day and date.

**Keltron Remote Printer.** The VS4095 is a two-color (red/black), 40-column, 24 VDC printer that can print 50 messages in 90 seconds. This printer connects to the control panel through an EIA-232 interface (TB14) and mounts in a separate cabinet next to the control panel. The VS4095 meets UL fire and security requirements for an ancillary device.

For more information, contact the manufacturer (Keltron Corp., Waltham, MA)

**Display Terminal - CRT-2.** This optional display terminal connects to the control panel through an EIA-232 interface (TB15). The terminal can control and view events, points and history reports, control the system (Acknowledge, Alarm Silence, and System Reset). The terminal displays 26 lines by 80 columns and can be located up to 50 feet (15.24 m) from the control panel within the same room.

**Note:** The CRT cannot be connected at the same time as the network.

## 2.10 Panel Circuit Modules

### Introduction

The control panel supports the following modules to control external circuits and relays:

- Indicating Circuit Module (ICM-4RK) & Indicating Circuit Expander (ICE-4)
- Control Relay Module (CRM-4RK) & Control Relay Expander (CRE-4)
- Auxiliary Relay Module (ARM-4)
- Voice Control Module (VCM-4RK), Dual Channel Module (DCM-4RK) & Voice Control Expander (VCE-4)

Up to eight of these modules (in any combination) can be controlled by the panel. Below are brief descriptions of the modules; for a description of VCM-4RK and DCM-4RK, see Section 2.11 “Voice Alarm System”.

### Indicating Circuit Module - ICM-4RK

Provides four (4) NACs for Style Y (Class B) or Style Z (Class A) operation. Circuits are field-programmable to respond to a single initiating zone, a group of zones, or all initiating zones. Maximum signaling current is 3 A per circuit or 6 A per module, limited by the power supply. An Auxiliary Power Harness (P/N 71091) is provided. **Note:** ICM-4RK is not listed for use with NFS-640 in releasing applications.

### Indicating Circuit Expander - ICE-4

An attaching circuit board that expands the ICM-4RK to a total of eight Style Y (Class B) or Style Z (Class A) NAC's. Maximum signaling current is 3 A per circuit or 6 A per module, limited by the power supply. An Auxiliary Power Harness (P/N 71091) is provided.

### Control Relay Module - CRM-4RK

Provides four (4) standard dry Form-C relay contacts. Each relay is field-programmable to respond to a single initiating device circuit, a group of circuits, or all initiating device circuits. Each relay features manual On/Off control switches and can be disabled or enabled. Contacts rated for 5 A at 120 VAC or 28 VDC (resistive). **Note:** CRM-4RK is not listed for use with NFS-640 in releasing applications.

### Control Relay Expander - CRE-4

An attaching circuit board that expands the capacity of the Control Relay Module (CRM-4RK) to eight (8) Form-C alarm relays. May also be used to expand the ICM-4RK to provide four (4) Form-C control relays. Contacts rated for 5 A at 120 VAC or 28 VDC (resistive).

### Auxiliary Relay Module ARM-4

Provides four (4) auxiliary Form-C relays that can be controlled by a CRM-4RK or CRE-4 relay module. Normally-open contacts rated for 20 A and the normally-closed contacts are rated for 10 A at 125 VAC and 30 VDC (resistive). An Auxiliary Power Harness (P/N 71092) is provided.



## 2.11 Voice Alarm System

### Introduction

Voice Alarm equipment provides a manual or automatic supervised paging system for transmitting voice messages (information, instructions, directions) on a selective or all call basis. For more information and installation instructions refer to the *Voice Alarm System* manual.

### Configuration

**VCC-1B Voice Control Center.** Basic equipment package for single-channel audio evacuation system that includes: AMG-1 Audio Message Generator (with microphone), CHS-4L Chassis, DPSW-1B Single-well Dress Panel, and Cable assemblies required to connect to control panel.

**VTCC-1B Voice/Telephone Control Center.** Basic equipment package for single-channel audio evacuation system employing a Fire Fighter's Telephone system that includes: FFT-7 Fire Fighter's Telephone, AMG-1 Audio Message Generator (with microphone), CHS-4L Chassis, DPDW-1B Double-well Dress Panel, and Cable assemblies required to connect to control panel.

**TCC-1B Telephone Control Center.** Basic equipment package for a Fire Fighter's Telephone system with no voice evacuation or paging capabilities that includes: FFT-7 Fire Fighter's Telephone, CHS-4L Chassis, TBP-1B Blank Panels (2), DPDW-1B Double-well Dress Panel, and Cable assemblies required to connect to control panel.

### Descriptions

**Audio Message Generator (AMG-1 & AMG-E).** Provides a variety of tones and a built-in microphone allows for paging through speaker circuits. Optionally, you can install up to four digitally-recorded voice messages into the AMG-1: two factory prerecorded voice messages, two user-defined messages. You can create both user-defined messages through the AMG-1 built-in microphone, or download messages from a standard audio cassette recorder. The AMG-E is an AMG-1 without a microphone. It is used for applications that require multiple Audio Message Generators.

**Fire Fighters Telephone (FFT-7 and FFT-7S).** Provides the Voice Alarm System with fire fighter's telephone capability. With these units, up to seven telephones can be used to hold a simultaneous conversation. The FFT-7S does not provide paging capability.

**Voice Control Module (VCM-4RK).** Provides the system with up to four (4) Style Y (Class B) or Style Z (Class A) speaker circuits, or up to four Style Y (Class B) telephone circuits. Moving a jumper on the module configures it for driving FFT-7 circuits. When configured for telephone circuits, the VCM-4RK accepts its signal directly from a Fire Fighters Telephone. Add an optional Voice Control Expander (VCE-4) to the back of the module to provide four additional telephone or speaker circuits.

**Dual Channel Module (DCM-4RK).** Provides the system with the capability to select one of two types of audio sources for switching to a specified speaker circuit. The module provides up to four circuits.

**Audio Amplifiers.** The control panel uses three types of audio amplifiers with an installed Voice Alarm System:

- AA-30 – Provides up to 30 watts of audio power for driving 25 Vrms speaker circuits.
- AA-100 – Provides 100 watts of audio power for driving 25 Vrms and 70.7 Vrms speaker circuits.
- AA-120 – Provides 120 watts of audio power for driving 25 Vrms speakers.

Each AA amplifies the audio signal coming in from an Audio Message Generator (AMG-1 or AMG-E).

**Audio Coupling Transformer ACT-1.** Couples low-level audio to audio amplifiers or other audio inputs, such as the AMG-1 Audio Message Generator. Provides Common Mode Noise Rejection (CMNR), greatly reducing crosstalk from the SLCs. For more information and installation instructions refer to the *Voice Alarm System* manual.

**Audio Coupling Transformer ACT-2.** When used with an AMG-1/-E, RM-1 and AA-30 this unit provides a means to drive thousands of amplifiers in large audio system applications. The ACT-2 provides electrical isolation between its input & output and attenuates the signal from high-level audio to low-level audio. For more information and installation instructions refer to the *ACT-2 Product Installation Drawing*.

### **Additional Devices**

The following devices are not part of the Voice Control System, but are listed here for continuity.

**Remote Microphone (RM-1 and RM-1SA).** Provides paging capabilities to speaker systems driven by the low level audio source of the AMG-1. The RM-1 assembly can be installed in a CAB-4 Series backbox, while the RM-1SA is installed in a CAB-RM cabinet. For more information and installation instructions see the *RM-1 Series Remote Microphone* installation document.

**Quad Intelligent Audio Transponder - XPIQ.** See product description on Page 20.

# Section 3 Installation

## 3.1 Preparing for Installation

Choose a location for the fire alarm system that is clean, dry, and vibration-free with moderate temperature. The area should be readily accessible with sufficient room to easily install and maintain it. There should be sufficient space for cabinet door(s) to open completely.

Carefully unpack the system and inspect for shipping damage. Count the number of conductors needed for all devices and find the appropriate knockouts. (Refer to Section 3.6 “UL Power-limited Wiring Requirements” for selection guidelines.)

Before installing the fire alarm system, read the following:

- Review the installation precautions at the front of this manual, including temperature and humidity limits for the system (Page 3).
- All wiring must comply with the National and Local codes for fire alarm systems.
- Do not draw wiring into the bottom 9 inches (22.86 cm) of the cabinet except when using a separate battery cabinet; this space is for internal battery installation.
- Review installation instructions in Section 3.2 “Installation Checklist”.



**CAUTION: Make sure to install system components in the sequence listed below. Failure to do so can damage the control panel and other system components.**



**WARNING: This system contains static-sensitive components. Always ground yourself with a proper wrist strap before handling any circuits. Use static-suppressive packaging to protect electronic assemblies removed from the unit.**

### 3.1.1 Standards and Codes

In addition, installers should be familiar with the following standards and codes:

- NEC Article 300 Wiring Methods.
- NEC Article 760 Fire Protective Signaling Systems.
- Applicable Local and State Building Codes.
- Requirements of the Local Authority Having Jurisdiction.
- C22.1-98 The Canadian Electrical Code, Part 1.
- CAN/ULC-S5524-01 Standard for the Installation of Fire Alarm Systems.

## 3.2 Installation Checklist

Table 2 provides an installation checklist for installing, wiring, and testing the NFS-640 system. It has references to installation information included in manuals listed in Section 1.2 “Supplemental Documentation”.

**Table 2 Installation Checklist**

Seq	Task	Refer to
1.	Mount the cabinet backbox to the wall.	Section 3.3 “Mounting a Cabinet”
2.	Install all required chassis in cabinet.	Section 3.5 “Installing the Control Panel”
3.	Install control panel onto chassis.	Section 3.5.1 “Control Panel Circuit Board & Keypad/ Display Unit”
4.	Optional: Install auxiliary power supply and/or external battery charger	Auxiliary power manuals
5.	Calculate the proper battery rating.	Appendix A “Power Supply Calculations”
6.	Connect AC wiring, place batteries into backbox without connecting them, and run cable to optional power supplies, DC power outputs, NACs, and relays. <b>CAUTION: Do not apply AC or DC power at this time.</b>	Section 13 “Mounting Single-space Blank Plate with Optional Module Connecting the Power Cables”
7.	Set switches for backup alarm (SW6-SW9).	Section 3.5.14 “Backup-Alarm Switches”
8.	Optional: Install and wire Auxiliary Relay Module (ARM-4).	Section 3.8 “Auxiliary Relay Module (ARM-4): Product-Specific Details”
9.	Optional: Install Panel Circuit Modules (ICM-4RK, CRM-4RK, VCM-4RK, DCM-4RK) and Voice Alarm System components (AMG-1, FFT-7, Audio Amplifiers)	Section 3.7 “Installing Panel Circuit Modules”, and <i>Voice Alarm System Manual</i>
10.	Optional: Install output devices such as a printer, or CRT terminal.	Section 3.9 “Installing Remote Printers and/or CRT”
11.	Optional: Install NCA or NCS.	<i>NCA Manual</i> or <i>NCS Manual</i>
12.	Secure any unused mounting holes in control panel circuit board.	Figure 8
13.	Wire the Signaling Line Circuits.	Section 3.10 “Wiring a Signaling Line Circuit (SLC)”
14.	Connect wire shielding as instructed.	<i>SLC Wiring Manual</i>
15.	Apply AC power to the control panel by placing the external circuit breaker to the ON position. <b>Do NOT connect batteries.</b>	
16.	Check AC power.	Table 4 in Section 13 “Mounting Single-space Blank Plate with Optional Module Connecting the Power Cables”
17.	Connect the batteries using interconnect cable, P/N 75560 and 75561.	
18.	Install the CAB-4 series door.	<i>CAB-3/CAB-4 Series Cabinet Installation Document</i>
19.	Program the control panel.	<i>NFS-640 Programming Manual.</i>
20.	Field test the system.	Section 5 “Testing the System”

### 3.3 Mounting a Cabinet

This section provides instructions for mounting an CAB-4 Series backbox to a wall. Follow these guidelines when mounting the backbox:

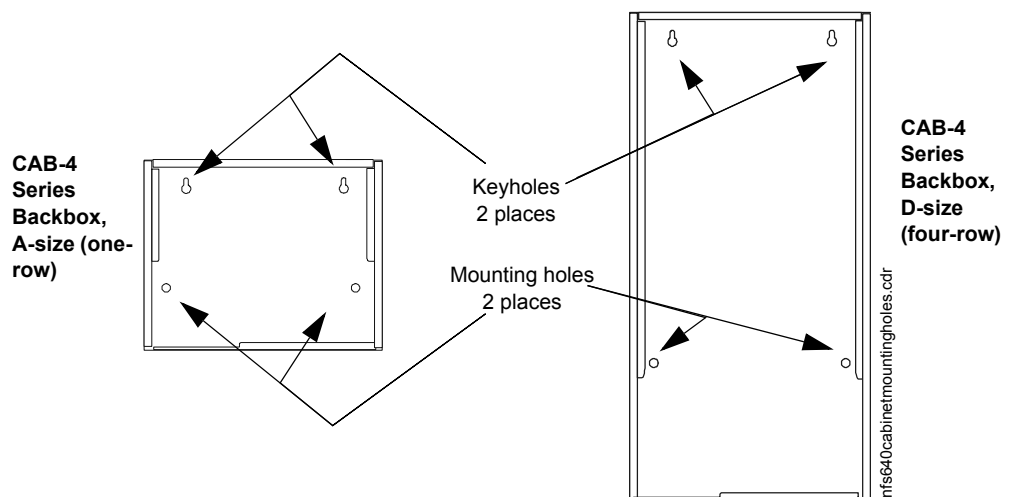
- Locate the backbox so that the top edge is 66 inches (1.6764 m) above the surface of the finished floor.
- Allow sufficient clearance around cabinet for door to swing freely. (See Section 2.3 “System Cabinets”.)
- Use the four holes in the back surface of the backbox to provide secure mounting (See Figure 5).
- Mount the backbox on a surface that is in a clean, dry, vibration-free area.

**CAUTION:** Unless you are familiar with the placement of components within this backbox, only use the knockout locations provided for conduit entry.

Follow the instructions below.

1. Mark and pre-drill holes for the top two keyhole mounting bolts (0.25 inch, 0.635 cm). Use mounting hardware appropriate for the mounting surfaces; see UL 2017 Pull-Test Requirements.
2. Select and punch open the appropriate knock-outs. (For selection guidelines, see Section 3.6 “UL Power-limited Wiring Requirements”.)
3. Using the keyholes, mount the backbox over the two screws.
4. Mark the location for the two lower holes, remove the backbox and drill the mounting holes.
5. Mount the backbox over the top two screws, then install the remaining fasteners. Tighten all fasteners securely.
6. Feed wires through appropriate knockouts.
7. Install control panel and other components according to Section 3.5 “Installing the Control Panel” before installing hinges and door according to *CAB-3/CAB-4 Series Cabinet Installation Document*.

**Figure 5 Mounting Holes of a Backbox**



### 3.4 Laying Out Equipment in Cabinet and Chassis

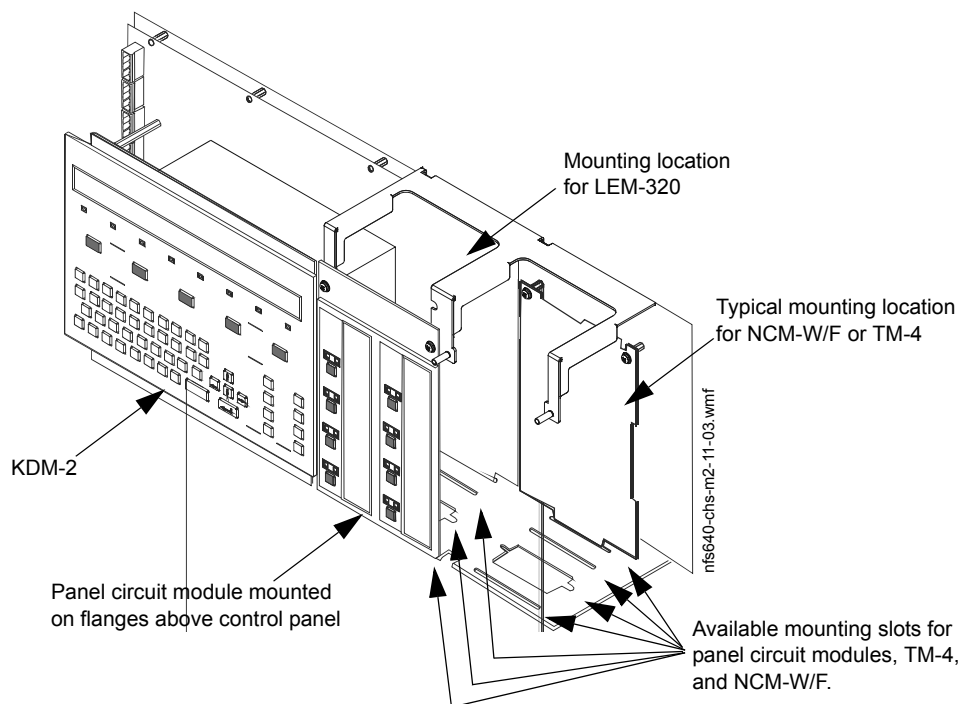
The NFS-640 allows for flexible system design. Follow these guidelines when deciding where to locate equipment in the backbox.

The first row of equipment mounts in chassis CHS-M2. Mount second, third, or fourth rows of equipment in chassis CHS-4N (panel circuit modules, see Section 3.7 “Installing Panel Circuit Modules”), or in chassis CHS-4L (voice components, see the *Voice Alarm System Manual*). Some equipment, such as the NCA and annunciators, may be door-mounted; refer to the equipment’s documentation for instructions.

There are four basic positions available on a chassis (side-by-side); the number of modules that can be mounted in each position depends on the chassis model and the module size.

The CHS-M2 accepts four layers of equipment, including the control panel. The control panel fills three positions in the first-installed layer, its integral power supply occupies two positions in the next two layers, and the optional display occupies the two left-most slots in the fourth layer (flush with the door). Panel circuit modules and other modules of the same sizing can be mounted in several layers, depending on the desired configuration; see Table 3 to determine hardware. Some equipment, such as the NCA, may be door-mounted directly in front of the control panel. The BMP-1 Blank Module Plate covers unused positions in a dress-panel, providing another mounting location for some modules, such as TM-4 (see *BMP-1 Product Installation Drawing* for details).

**Figure 6 Equipment Mounting Locations (First-Row Chassis CHS-M2)**



**Note:** When designing the cabinet layout, consider separation of power-limited and non-power-limited wiring as discussed in Section 3.6 “UL Power-limited Wiring Requirements”.

Table 3 Stand-off Lengths

From...	To...	Required Stand-off or Hardware
Chassis CHS-M2	Control panel or module on first layer	Not applicable; integral to the chassis.
Control panel or Option board, 1st layer	Option board, 2nd layer (includes LEM-320)	4 male-female stand-offs of length 0.937 inch (23.8 mm) P/N 42166.
Option board, 2nd layer	Option board, 3rd layer	4 male-female stand-offs of length 0.937 inch (23.8 mm) P/N 42166.
Chassis	Option board, 4th layer (flush with door)	Attaches directly to flanges on chassis. (Screws provided with option boards & panel circuit modules)
Chassis	Panel circuit module (flush with door)	Attaches directly to flanges on chassis. (Screws provided with option boards & panel circuit modules)
Control panel	KDM-2 (upper edge)	2 stacks of male-female stand-offs: •P/N 42185 (2.0 inch, 50.8 mm) and •P/N 42186 (1.312 inch, 33.33 mm)
Chassis rail	KDM-2 (lower edge)	2 male-female stand-offs of length 0.937 inch (23.8 mm) P/N 42166.
Dress panel DP-DISP or ADP-4B	NCA	Attaches directly to dress panel. (Nuts provided with NCA.)
Dress panel DP-DISP or ADP-4B	Option board	BMP-1 attaches to dress panel; option module attaches to BMP-1 (screws provided with option module).

**Note:** The initial release of chassis CHS-M2 used L-brackets and stand-offs of different lengths than the current model; refer to Doc. 51332, Rev A.

## 3.5 Installing the Control Panel

### 3.5.1 Control Panel Circuit Board & Keypad/Display Unit

The control panel mounts in chassis CHS-M2, which is usually positioned in the top row of the backbox. The control panel's CPU occupies three positions at the back of the chassis; the KDM-2 occupies two positions flush with the door. The NCA may be door-mounted directly in front of the control panel if no KDM-2 is being used; see the *NCA Manual* for details and restrictions.

Note: For initial release of NFS-640, mounting instructions were different. Refer to the installation manual shipped with the panel (Rev A).

1. Verify height of the mounting stud in the backbox. In older backboxes, the stud must be shortened to prevent damage to the CPU-640. All electronics must be removed from the backbox before shortening. See instructions in the warning below.

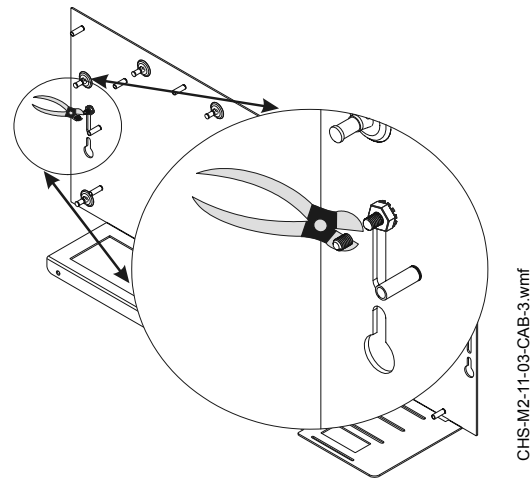


**WARNING:** For retrofit applications, verify the height of the backbox's mounting stud on left side under CPU, as shown in Figure 7 below. Stud height must not exceed 0.375 in. (9.525 mm). Early versions of the CAB-4 Series backboxes and all CAB-3 Series backboxes have studs that require shortening.

Failure to shorten this 0.625 in. (15.875 mm) mounting stud will cause damage to the control panel's CPU. Remove electronics from backbox, permanently mount empty CHS-M2 chassis to backbox, apply nut to mounting stud to protect threading, then cut stud to proper length. Reinstall electronics as discussed in the steps below.

**Figure 7 Using the Redesigned CHS-M2 with Older Backboxes**

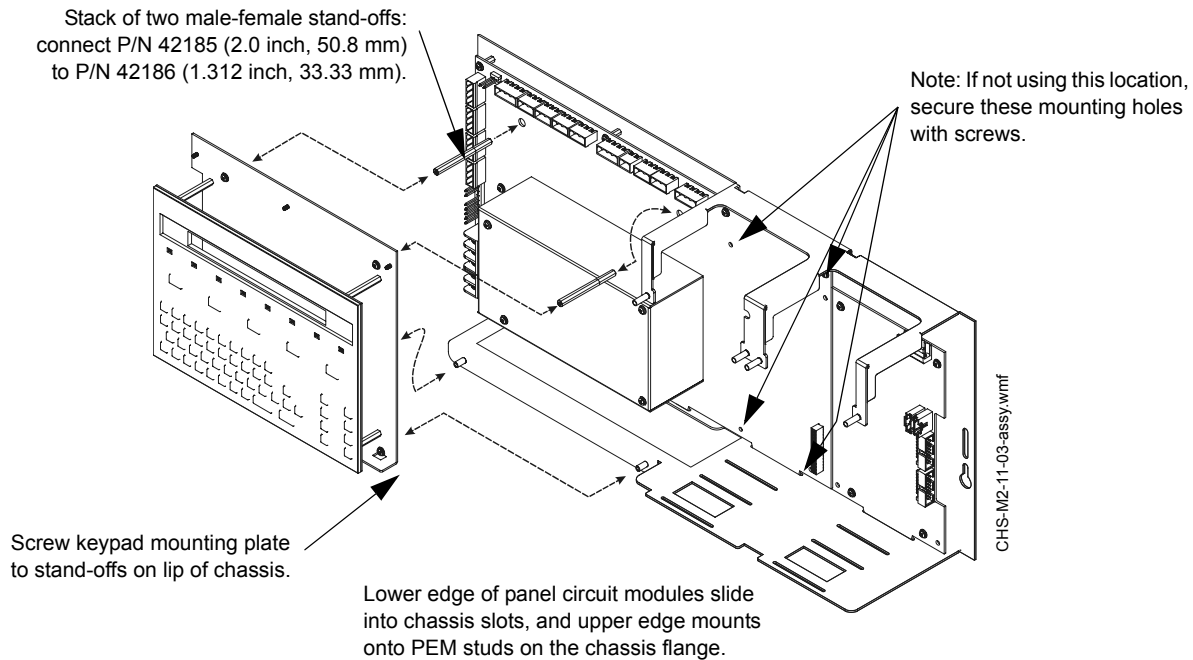
If using a new CHS-M2 in a CAB-3 series backbox or in a CAB-4 series backbox manufactured before November 2003, verify stud height and cut any stud that exceeds 0.375 in. (9.525 mm) as per Step 1 above if a CPU is being mounted above it. Reinstall electronics as discussed in the steps below.



2. Screw chassis to the backbox.
3. Attach CPU-640 to the chassis. Slide control-panel tabs into slots on chassis and lay the board onto stand-offs so that mounting holes line up with those on the chassis. Secure with six (6) screws (four across the top of the board, and two to the left of the power supply) provided with the chassis. (See Figure 8.)
4. If installing KDM-2, install the stand-offs included with the keyboard kit. (See Figure 8.)
  - The upper edge of the keyboard mounting plate rests on two stacked pairs of male-female stand-offs. Connect P/N 42185 (2.0 inch, 50.8 mm) to P/N 42186 (1.312 inch, 33.33 mm).
  - Thread the stacked pairs of stand-offs through mounting holes on the control panel as shown in Figure 8.
  - Thread two P/N 42166 0.937 inch (23.8 mm) male-female stand-offs through mounting holes in the chassis rail.
  - Attach ribbon cable from keypad to J4 connector on control panel. (See Figure 3.)
  - Align the keypad with the stand-offs and screw it down.
5. If using the NCA instead of the KDM-2, refer to Section 3.5.2 “Using NCA as Primary Display” and the *NCA Installation Manual*.
6. If not using an LEM-320, secure the last 4 mounting holes with screws.



**Figure 8 Locating and Aligning Stand-offs for Keypad/Display and Panel Circuits (Chassis CHS-M2 shown)**



**CAUTION:** It is critical that all mounting holes of the NFS-640 are secured with a screw or standoff to insure continuity of Earth Ground.

### 3.5.2 Using NCA as Primary Display

The NFS-640 can be set up to use an NCA instead of a KDM-2. In this system design, connect the network port on the NFS-640 (J1) directly to the network port on the NCA (J3); see the *NCA Manual* for specific instructions.

**Note:** This system design is required in Canadian stand-alone applications.

If the NFS-640 and NCA are being used as a stand-alone pair, each device must be programmed separately using VeriFire Tools in its off-line programming mode. Because the VeriFire Tools computer also uses the network port, NFS-640 and NCA must be temporarily disconnected for programming. If the NFS-640 with NCA is connected to a network, there are two additional options for programming: either connect the VeriFire Tools programming PC to the network port on the NCM board, or program the NFS-640 through another network node. (See VeriFire Tools on-line help for details.)

### 3.5.3 Loop Expander Module

Installing a Loop Expander Module adds a second SLC loop to the control panel. Refer to the Figure 10 for connector illustrations.

1. Thread four (4) 0.937 inch (23.8 mm) stand-offs through indicated holes in the CPU-640 board.
2. Plug stacker-connector into J3 on the CPU-640.
3. Lay the LEM onto the standoffs and connect the Loop Expander Module (LEM) into the stacker-connector attached to J3.
4. Attach LEM using screws provided with the module.
5. After LEM is mounted on the control panel, connect the SLC loops to TB1 on the LEM and TB16 on the CPU-640.

This system supports either FlashScan or CLIP mode devices. Refer to the SLC loop manual for wiring requirements and specific details.

Figure 9 SLC Connections for LEM-320

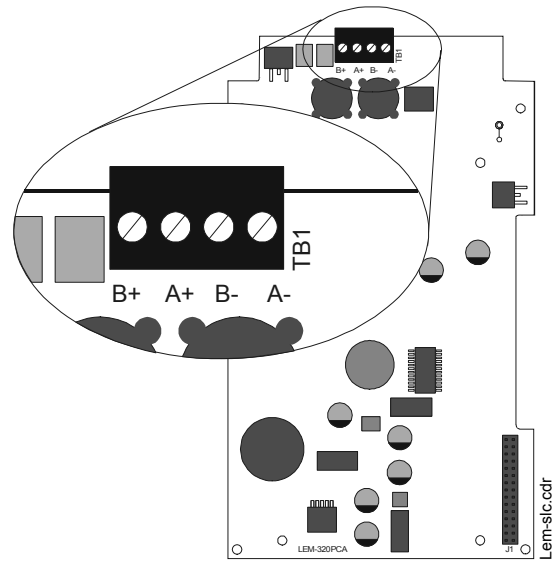
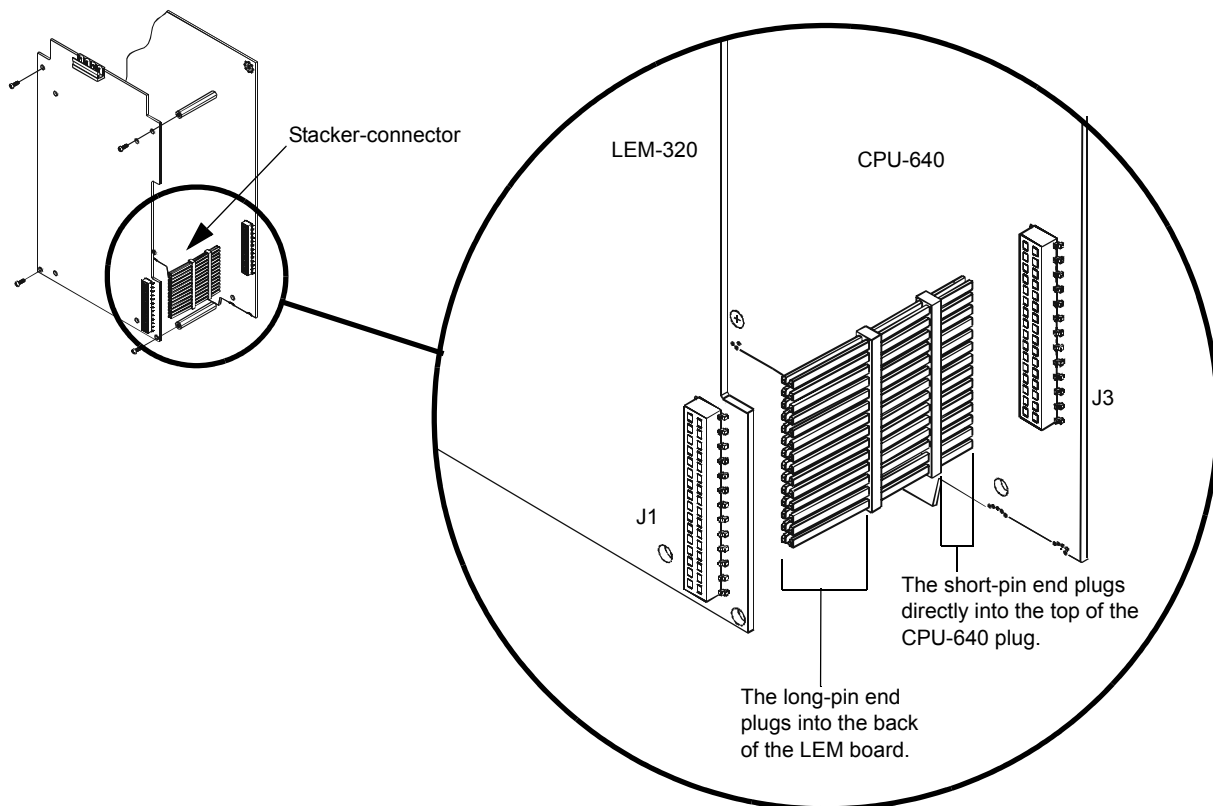


Figure 10 Mounting LEM-320 with the Stacker-connector



**CAUTION:** If the stacker-connector is installed incorrectly, the short-pin end of the plug can fail to make a secure connection when plugged through the back of the LEM.

### 3.5.4 Network Control Module

If networking two or more control panels, each unit requires a Network Control Module; wire and fiber versions are available. The NCM-W/F can be installed in any panel circuit module position (see Section 3.5.5 “Panel Circuit Modules and Other Option Boards”); the default position is immediately to the right of the control panel.

1. Mount the NCM in the selected position. If another board is going to be mounted in the slot immediately in front of it, use stand-offs provided with the next board to secure it in place. Otherwise use the screws provided with the NCM.
2. Connect J1 on the control panel to J3 on the NCM using the network cable provided (P/N 75556).
3. Connect Channel A and/or Channel B as described in the *NCM Installation Document*.

**Note:** See the *Noti•Fire•Net Manual* and *NCM Installation Document* for system configuration information. See the *BMP-1 Product Installation Drawing* if considering mounting the module behind blank module plate in a dress plate or annunciator backbox.

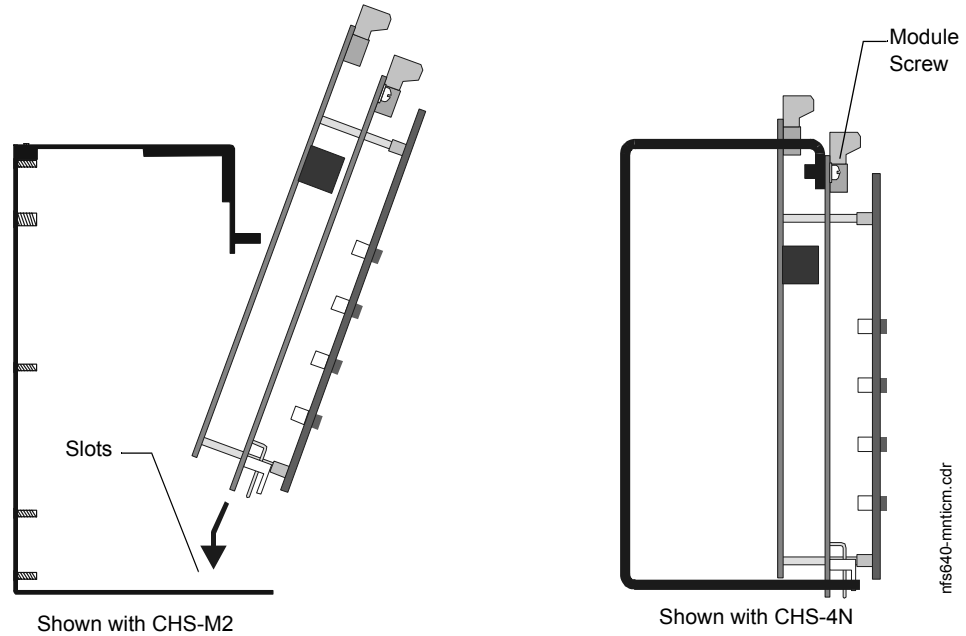
### 3.5.5 Panel Circuit Modules and Other Option Boards

If installing option boards into a CAB-4 Series backbox, mount & connect those boards at this time. General instructions follow; the sections about individual option boards contain any module-specific instructions. Option boards can be mounted in the front (fourth) layer of CHS-M2 (see flanges as shown in Figure 8), or in any position on the other row(s) of equipment, using 0.937" (23.8 mm) standoffs between layers.

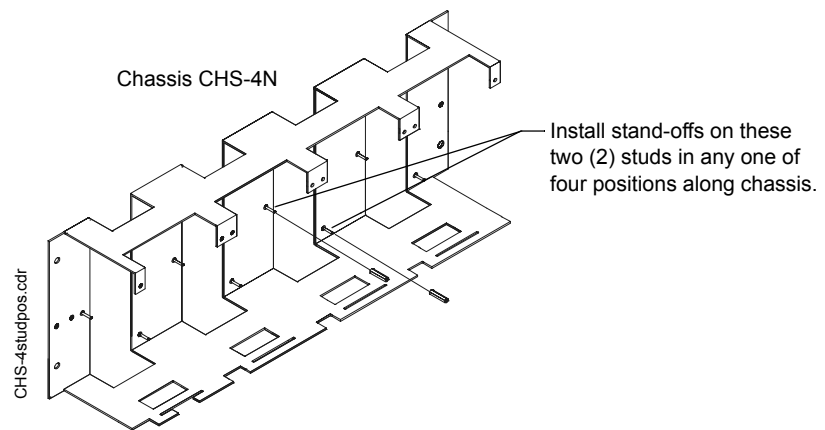
**Note:** An option board can be mounted above a Loop Expander Module or Network Control Module; for ease of access, be sure to complete installation of those devices before mounting a second layer.

1. Slide the tabs at the bottom of the option board into slots on the chassis as shown in Figure 11.
2. Lay the board back onto the flanges so that the studs line up with mounting holes on the option board.
3. Attach the option board using screws provided with the module.

**Figure 11 Inserting a Module into a Chassis**

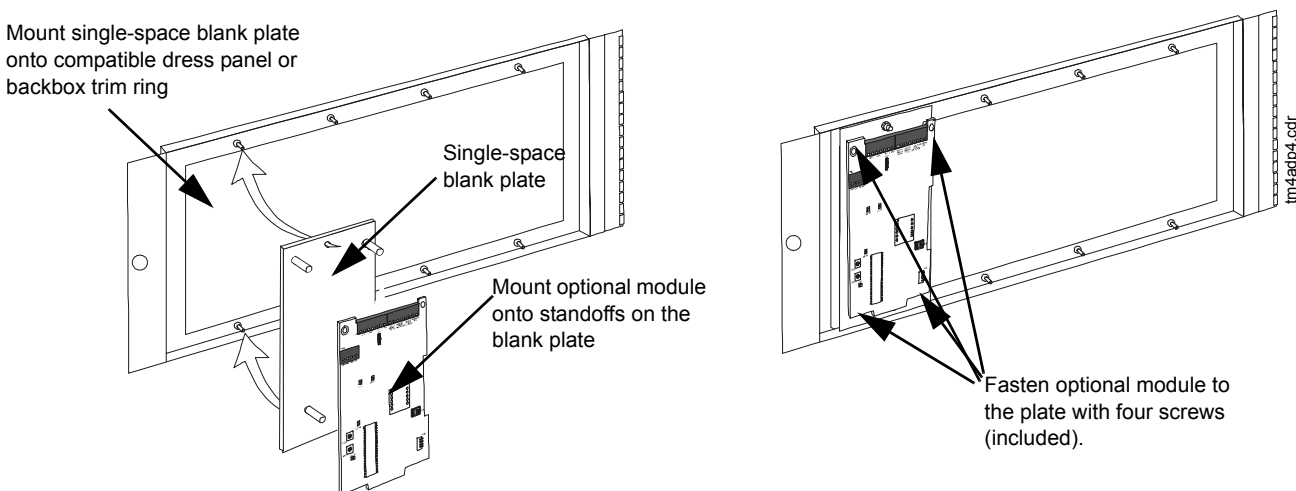


**Figure 12 Location of Stand-offs on Module Chassis**



**Note:** See the *BMP-1 Product Installation Drawing* for details if considering mounting the module behind blank module plate in a dress plate or annunciator backbox. This dress plate is suitable for modules that do not need to be visible or accessible when the door is closed.

**Figure 13 Mounting Single-space Blank Plate with Optional Module Connecting the Power Cables**



**⚠ WARNING:** Remove all power sources to equipment while connecting electrical components. Leave the external, main power breaker OFF until installation of the entire system is complete.

**⚠ WARNING:** Several sources of power can be connected to the control panel. Before servicing the control panel, disconnect all sources of input power *including the battery*. While energized, the control panel and associated equipment can be damaged by removing and/or inserting cards, modules, or interconnecting cables.

### 3.5.6 Overview

Complete all mounting procedures and check all wiring before applying power. Electrical connections include the following:

- Primary AC power source – 120 VAC, 50/60 Hz, 3.0 A (NFS-640E uses 240 VAC, 50/60 Hz, 1.5 A) from line voltage source. Overcurrent protection for this circuit must comply with Article 760 of the National Electrical Code (NEC) and/or local codes. Use 12 AWG (2.00 mm<sup>2</sup>) wire (maximum) with a 600-volt rating.
- Secondary power source – 24 VDC from batteries, installed in the control panel (or in an optional battery cabinet). Secondary (battery) power is required to support the system during loss of primary power.
- External power sources – 24 VDC power for Smoke Detectors (4 wire), NACs, and Annunciators.

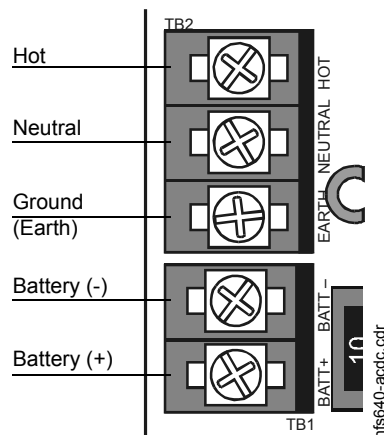
See Appendix B “Electrical Specifications” for details and overall installation guidelines.

### 3.5.7 Connecting the Control Panel to AC Power

Connect primary power as follows (see Figure 14 below):

1. Turn off the circuit breaker at the main power distribution panel.
2. Remove the plastic insulating cover from TB2.
3. Connect the service ground to terminal marked EARTH.
4. Connect the primary neutral line to terminal marked NEUTRAL and the primary Hot line to terminal marked HOT.
5. Reinstall the plastic insulating cover over TB2.

**Figure 14 AC & DC Power Connections**



### 3.5.8 Checking AC Power

Table 4 contains a checklist for checking the system with AC power applied:

**⚠ CAUTION: While checking AC power, make sure batteries are not connected. Follow the sequence of steps in Section 3.2 “Installation Checklist”, Table 2; this is Step 16.**

**Table 4 AC Power Checklist**

Component	Status
Control panel circuit board	The green AC Power indicator on; the system Trouble indicator on because batteries are not connected.
Each panel circuit module	The yellow Trouble indicator may come on for approximately 10 seconds after applying AC power. (This only applies to an unconfigured system.)
Each auxiliary power supply	The yellow Trouble indicator comes on because batteries are not connected.

### 3.5.9 Installing and Connecting the Batteries

**⚠ WARNING: Battery contains sulfuric acid which can cause severe burns to the skin and eyes, and can destroy fabrics. If contact is made with sulfuric acid, immediately flush skin or eyes with water for 15 minutes and seek immediate medical attention.**

**⚠ WARNING: Do not connect the Battery Interconnect Cables (P/N 75560 and 75561) at this time. Make this connection AFTER initial system primary powerup. Follow sequence of steps in Section 3.2 “Installation Checklist”, Table 2; this is Step 17.**

Batteries (2) are installed in the control panel cabinet or in a separate battery cabinet which can be mounted below the control panel or up to 20 feet (6.096 m) away from the control panel, in the same room.

Connect the battery as follows (see Figure 14 above):

1. Install batteries (2) into bottom of cabinet or into separate battery cabinet.
2. Connect the red cable from TB1(+) on the control panel to the positive (+) terminal of one battery.
3. Connect the black cable from TB1(-) on the control panel to the negative (-) terminal of the **other** battery.
4. Connect the remaining cable between the negative (-) terminal on the first battery to the positive (+) terminal on the second battery.

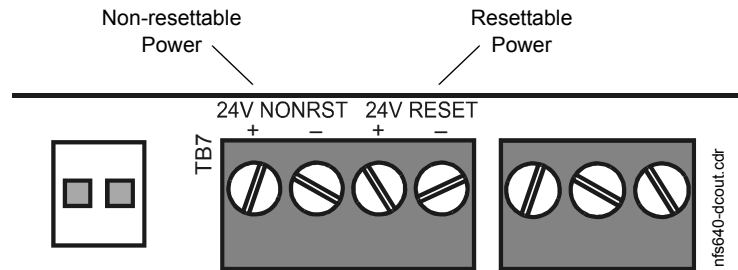
### 3.5.10 APS-6R Auxiliary Power Supply Connections

If an optional APS-6R power supply is installed in the cabinet, connect it with no power applied; follow sequence of steps in Section 3.2 “Installation Checklist”, Table 2; this is Step 4. For all information pertaining to these connections see the *APS-6R Instruction Manual*.

### 3.5.11 External DC Power Output Connections

Terminal TB7 provides two (2) power outputs, resettable and non-resettable. Each output is power-limited. Follow sequence of steps in Section 3.2 “Installation Checklist”, Table 2; this is part of Step 6.

**Figure 15 Power Supply DC Outputs - TB7**



**24 VDC Resettable Power Circuit (Four-Wire Smoke Detectors).** The power supply provides a single 24 VDC filtered, power-limited, resettable power circuit for devices that require resettable power (such as four-wire smoke detectors). This circuit is power-limited, but must be supervised. To provide supervision, install a UL-listed end-of-line power supervision relay (such as the A77-716B) after the last device. Connect the power supervision relay normally open contact in series with an Initiating Device Circuit (IDC). The four-wire power circuit energizes the power supervision relay. When you reset the system, the control panel removes power from these terminals for approximately 15 seconds.

Connect external field wires to the power supply terminals TB7 RESET(+)and(–) to provide up to 1.25 A of current for powering four-wire smoke detectors. See Figure 15 above.

**24 VDC Non-resettable Power Circuit.** The power supply provides one 24 VDC filtered, power-limited, non-resettable power output, capable of up to 1.25 A. Use this circuit to power devices that require low-noise 24 VDC power (such as annunciators or the TM-4).

Connect external field wires to power supply terminals TB7 NONRST(+)and(–) to provide up to 1.25 A of non-resettable current for powering external devices such as annunciators. See Figure 15 above.



**CAUTION: During system reset, power remains at terminals TB7 NONRST(+)and(–).**

### 3.5.12 NAC Connections & Releasing Circuits

The control panel provides four NAC terminals as shown in Figure 16. Each can be configured as Style Y (Class B) or Style Z (Class A) as shown in Figure 17. Each circuit can provide 2.5 A of current, but the total current drawn from the main power supply cannot exceed 6.0 A in alarm condition (refer to Table 12). NAC circuits are supervised and power-limited. Use UL-listed 24 VDC notification appliances only (refer to the Notifier *Device Compatibility Document*).

**Note: Any NAC can be programmed as a releasing circuit, but only one releasing device per circuit is allowed.** For more information, refer to Section 4.5 “Releasing Applications” in this manual and the *NFS-640 Programming Manual*. Refer to the *Device Compatibility Document*, for UL-listed compatible releasing devices. Sample connections for NAC terminals are shown in Figure 17. Follow sequence of steps in Section 3.2 “Installation Checklist”, Table 2; this is part of Step 6.

Figure 16 NAC Terminals

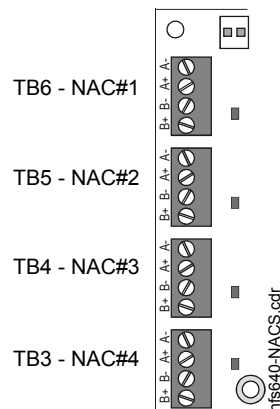
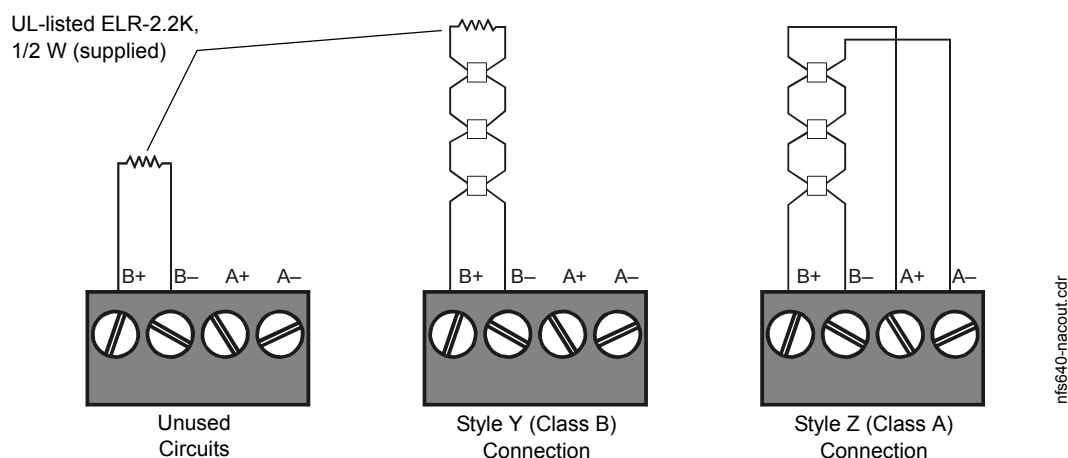


Figure 17 Notification Appliance/Releasing Circuit Connections



### 3.5.13 Output Relay Connections

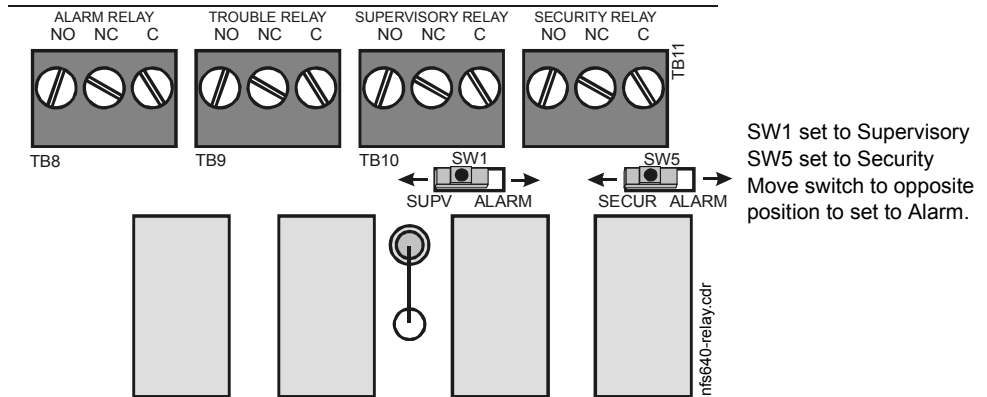
The panel provides a set of Form-C relays. These are rated for 2.0 A at 30 VDC (resistive):

- Alarm - TB8
- Trouble - TB9
- Supervisory - TB10
- Security - TB11

The Supervisory and Security contacts can also be configured as Alarm contacts by setting switches SW1 and SW5 away from the factory default positions shown in Figure 18. Follow sequence of steps in Section 3.2 “Installation Checklist”, Table 2; this is part of Step 6.



**Figure 18 Form-C Relay Connections**



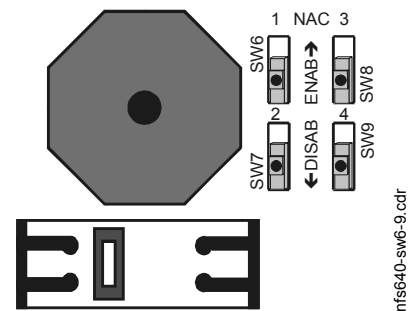
### 3.5.14 Backup-Alarm Switches

**⚠ WARNING: Do not enable the BACKUP option switch for any of the four Notification Appliance Circuits (NACs) if they are used for releasing functions!**

Backup alarm switches are provided that enable NACs and the alarm relay to activate during a backup alarm condition. If the main board’s microcontroller fails and an alarm is reported by any detector or a monitor module that has backup reporting enabled, the NAC will turn on if the corresponding switch was enabled. The alarm will activate during microcontroller failure regardless of the settings of Switch 6-9.

- Switch 6 - NAC#1
- Switch 7 - NAC#2
- Switch 8 - NAC#3
- Switch 9 - NAC#4

**Figure 19 Backup Alarm Switches**



So, for example, if Switch 6 and Switch 8 were enabled at the time of an alarm during microcontroller failure, NAC#1 and NAC#3 would activate. Follow sequence of steps in Section 3.2 “Installation Checklist”, Table 2; this is Step 7.

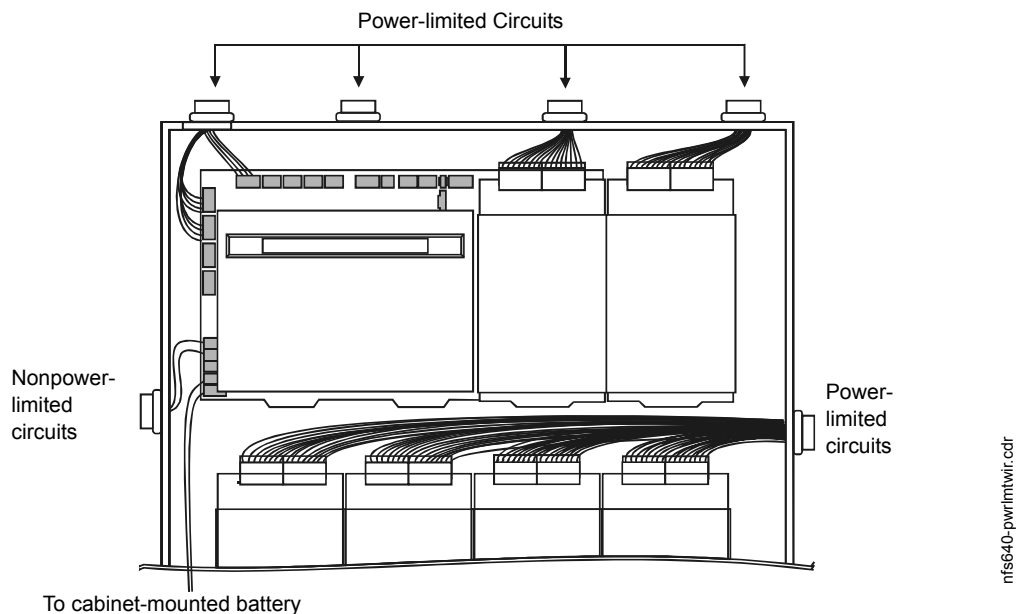
### 3.5.15 Installing a Transmitter Module TM-4

TM-4 is power-limited. Connections are on TB7 nonresettable output and TB13 EIA-485 ACS Mode. Refer to the *Transmitter Module TM-4* installation document for installation details.

## 3.6 UL Power-limited Wiring Requirements

Power-limited and nonpower-limited circuit wiring must remain separated in the cabinet. All power-limited circuit wiring must remain at least 0.25 inches (6.35 mm) from any nonpower-limited circuit wiring. All power-limited and nonpower-limited circuit wiring must enter and exit the cabinet through different knockout and or conduits. To maintain separation, group non-power limited modules together, i.e., group modules on the same side of the enclosure or in separate rows.

Figure 20 shows one configuration that meets these UL requirements. The first two rows of modules are configured with at least a 0.25 inch (6.35 mm) separation between power-limited and nonpower-limited wiring; AC and battery wiring is routed away from power-limited wiring.



**Figure 20 Typical Wiring for UL Power-limited Wiring Requirements**

**Note:** AC and battery wiring are not power-limited. Maintain at least 0.25 inches (6.35 mm) between power-limited and non power-limited circuit wiring. Install tie wraps and adhesive squares to secure the wiring. Use a power-limited source for relay output on terminals TB8 – TB11.

### 3.6.1 Labeling Modules and Circuits

At the time of installation, each nonpower-limited circuit connected to ACM-8R, ARM-4, CRM-4RK, CRE-4, and LDM-R32 modules must be identified in the space provided on the cabinet door label when connected to a non-power-limited source of power.

The label lists all compatible power-limited modules and circuits; also see Figure 3 at the start of this manual.

The following devices are power-limited only when connected to power-limited sources: ARM-4, CRM-4RK, CRE-4, LDM-R32. When one of these devices is connected to a non-power-limited source, the power-limited marking must be removed.

## 3.7 Installing Panel Circuit Modules

### 3.7.1 Overview

Installation of a panel circuit module is divided into five (5) operations:

- Mounting an optional expander board to the module (e.g. mounting ICE-4 onto an ICM-4RK).
- Connecting communication ribbon cables from Control Panel to the module.
- Installing the module onto a chassis.
- Connecting modules to the power supply.
- Field wiring the module.

Refer to Section 2.10 “Panel Circuit Modules” for a complete list of modules and their expanders.

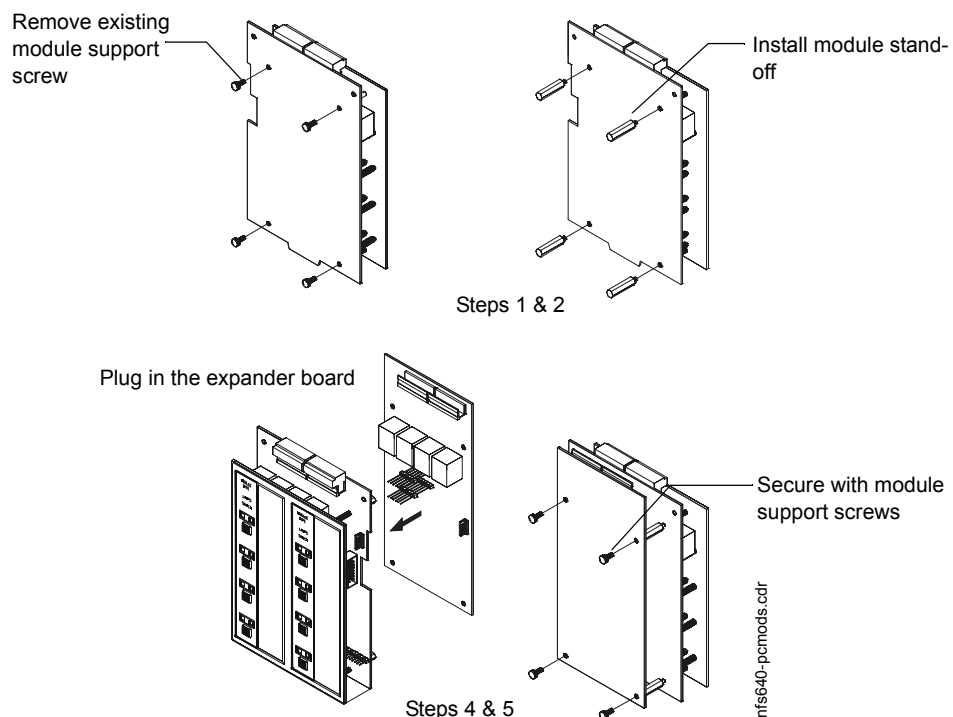
### 3.7.2 Mounting Expander Boards

Expander Board Modules, such as ICE-4 or CRE-4, need to be mounted onto their respective modules (ICM-4RK, CRM-4RK) prior to installation onto a chassis. To mount an Expander Module:

1. Remove one module support screw and set it aside for later use.
2. Replace the module support screw with one module stand-off.
3. Repeat Steps 1 and 2 for the three remaining module support screws.
4. Insert pins on the front of the expander board into connector on the back of the module. Make sure the pins are in line; then, press the two units together until they snap into place.
5. Install the four module support screws (removed earlier) through the back of the expander board and into the stand-offs. Tighten securely.

Figure 21 illustrates the steps.

**Figure 21 Expander Module Installation**

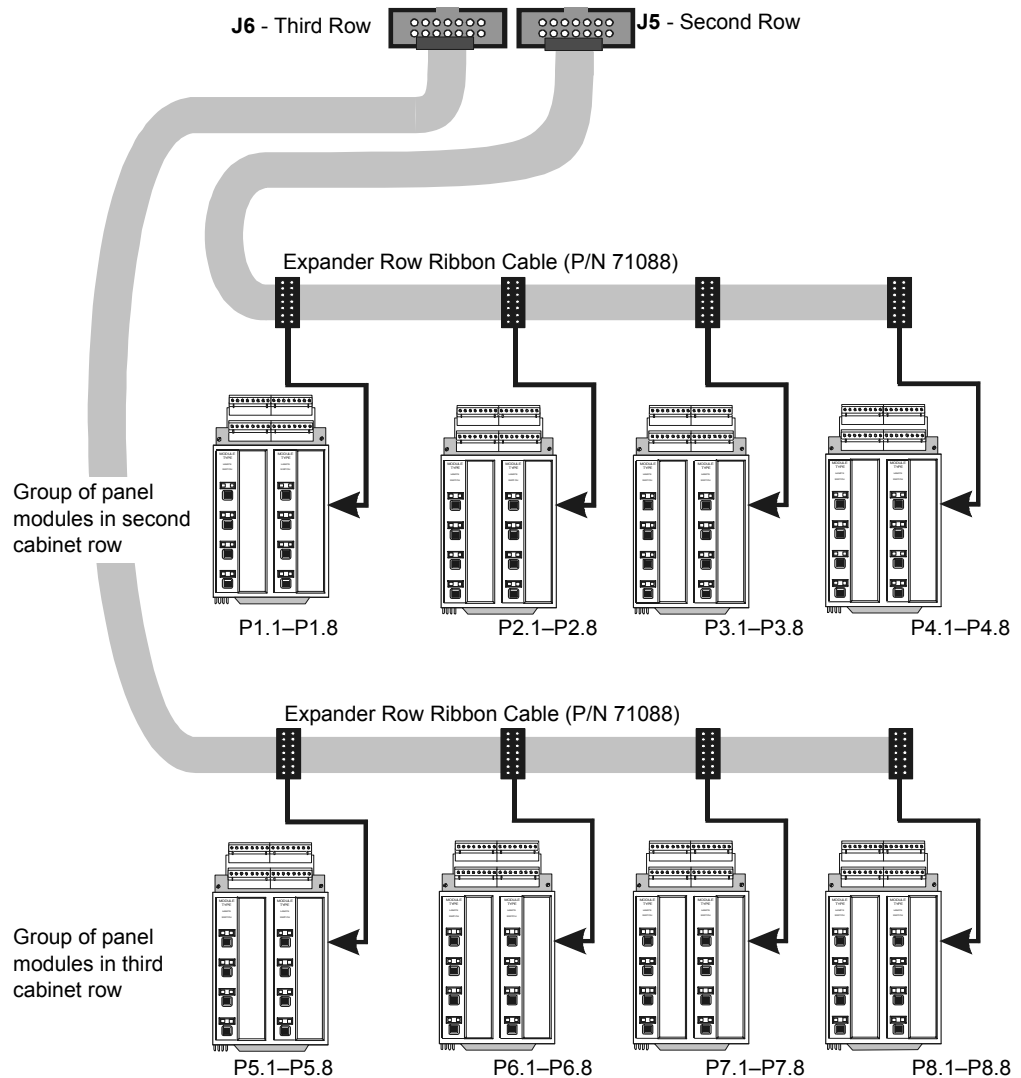


### 3.7.3 Connecting Ribbon Cables for a CAB-4 Series Backbox

Expander Row Ribbon Cables connect panel circuit modules to the Control Panel.

Figure 22 shows a typical wiring setup using two Expander Row Ribbon Cables (P/N 71088) to connect the control panel to two rows of four (4) panel circuit modules each below the Control Panel in a CAB-4 Series backbox.

**Figure 22 Expander Row Ribbon Cable Setup**



### 3.7.4 Installing the Panel Circuit Modules

To install a panel circuit module such as a ICM-4RK or CRM-4RK into the chassis:

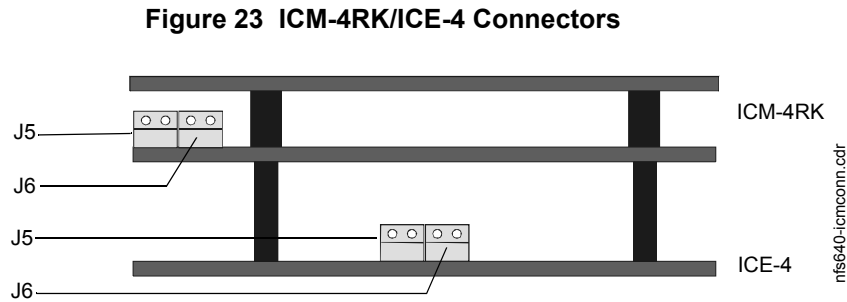
1. Angle the module into the chassis so that the lower board edge slips into the chassis slots as shown in Figure 11.
2. Push the upper end of the module into the upper opening in the chassis.
3. Secure the module to the chassis with the two module screws (provided with the module). Tighten securely.
4. Connect the Ribbon Cable to the module.

### 3.7.5 Connecting ICM-4RK and ICE-4 Modules

The total current available for any group of Notification Appliance Circuits (NACs), other than the four NACs on the control panel, cannot exceed the following:

- 6.0 A when powered from the APS-6R
- 1.25 A when powered from a NFS-640 DC power output terminal

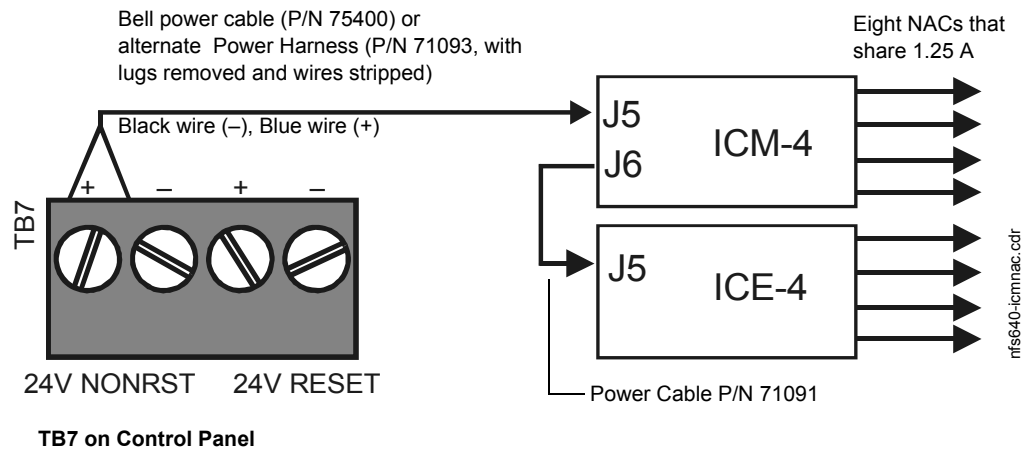
Shown below are the wire connectors on the bottom of the ICM-4RK and the ICE-4 modules.



### Power Supply Connections

The figure below illustrates typical connections from main power supply.

**Figure 24 Main Power Supply Connection**

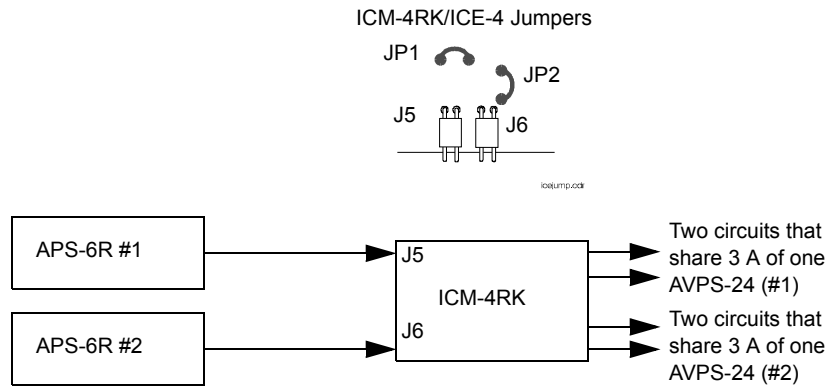


### Multiple Power Supplies

Cut JP1 and JP2 on ICM-4RK when supplying 24V power from two separate sources to the ICM-4RK. ICM-4RK circuits 1-2 will receive their power from J5; ICM-4RK circuits 3-4 will receive their power from J6.

Cut JP1 and JP2 on ICE-4 when supplying power from separate sources to expander circuits 5-8. ICM-4RK circuits 5-6 will receive power from J5 on the ICE-4 and ICM-4RK circuits 7-8 will receive power from J6 on the ICE-4.

See Figure 25 for jumper locations.

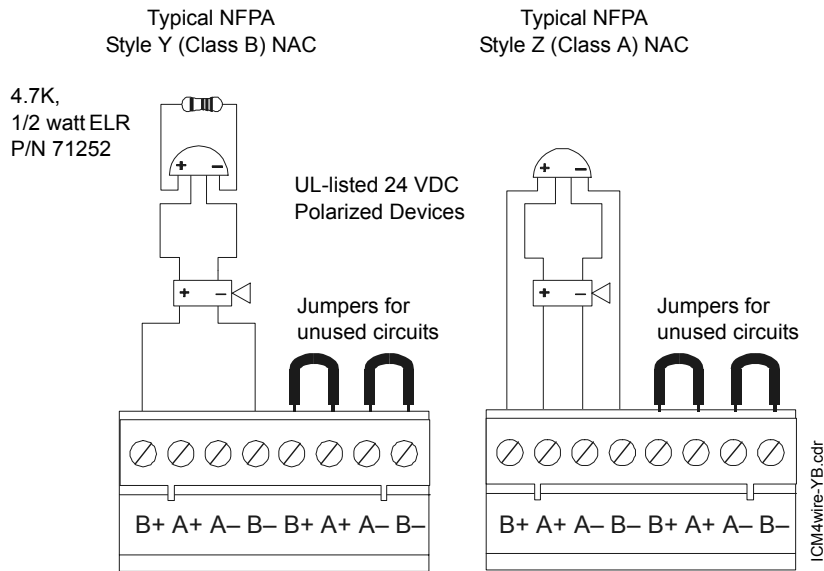
**Figure 25 Sample ICM-4RK Configuration for Multiple Power Supplies**

### 3.7.6 Field-Wiring the ICM-4RK and ICE-4 (NFPA Style Y or Z)

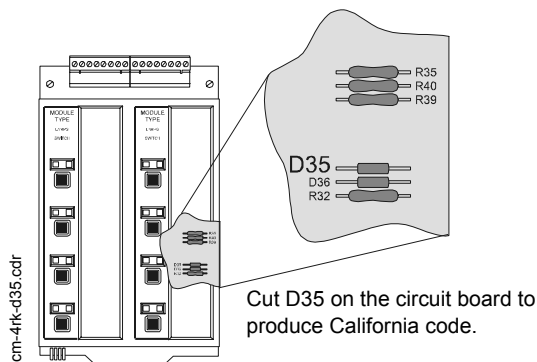
Guidelines for field-wiring:

- Notification Appliance Circuits (NACs) are supervised, power-limited, and can connect to an energy-limited cable.
- Use only the compatible, UL-listed notification appliances listed in the Device Compatibility Document.
- Wire notification appliances according to the manufacturer's instructions.
- Maximum current per circuit is 3.0 A. Maximum current per module depends on the type of power supply (standard or auxiliary).
- Canadian installations require model N-ELR End-of-Line Resistor Assembly (Style Y only).
- Size NAC wiring so the voltage drop does not exceed the minimum rated voltage of the notification appliance used as the last device on the circuit.
- For zone coded applications, refer to the *UZC-256 Universal Zone Coder* manual.
- The ICM-4RK is California Code programmable (microprocessor P/N 34077 Rev. B or higher). To program for California Code, cut diode D35 as shown in Figure 27. (See appendix section of the Programming Manual for more detail.)

**Figure 26 Field-Wiring an ICM-4RK/ICE-4**



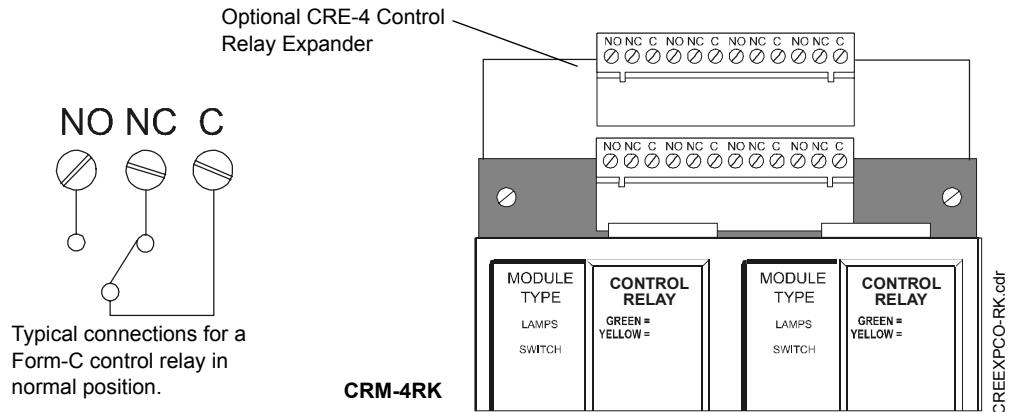
**Figure 27 Location of D35 on ICM-4RK Circuit Board**



### 3.7.7 Connecting CRM-4RK/CRE-4 Modules

Guidelines for field-wiring the CRM-4RK and the CRE-4:

- Provide Form-C relay contacts (silver alloy) used for medium duty switching or pilot duty.
- Terminals will accept wire sizes from 12 AWG to 18 AWG (3.1 to 0.78 mm<sup>2</sup>).
- Activation of a module or expander relay occurs automatically when an alarm is detected on a programmed IDC.
- UL contact ratings are 5 A at 125 VAC (resistive) or 30 VDC (resistive) and 2 A at 125 VAC (inductive).
- For more information, refer to Section 3.6 “UL Power-limited Wiring Requirements”.
- For typical field-wiring connections, refer to Figure 28.

**Figure 28 Field-Wiring a CRM-4RK or CRE-4 Module**

## 3.8 Auxiliary Relay Module (ARM-4): Product-Specific Details

### 3.8.1 Overview

If a CRM-4RK/CRE-4 is to be incorporated into the control panel and an ARM-4 is being driven by it, note the following:

- Each ARM-4 must be supported by one CRM-4RK or one CRE-4.
- If using ARM-4's for both modules, mount two ARM-4's in separate positions.
- If mounted in FACP enclosure keep all non-power limited wiring separate from power limited wiring.

For ease of installation, service, and wiring mount the ARM-4 module in a position on the chassis that will not have any other module or expander board in front of it. However, you can install the ARM-4 directly behind the CRM-4RK or CRE-4.

ARM-4 mounts in the second, third or fourth row of a CAB-4 series backbox, against the back of a chassis CHS-4 or CHS-4L. The ARM-4 may be mounted in any of the 8 adjacent backbox positions the cable can reach.

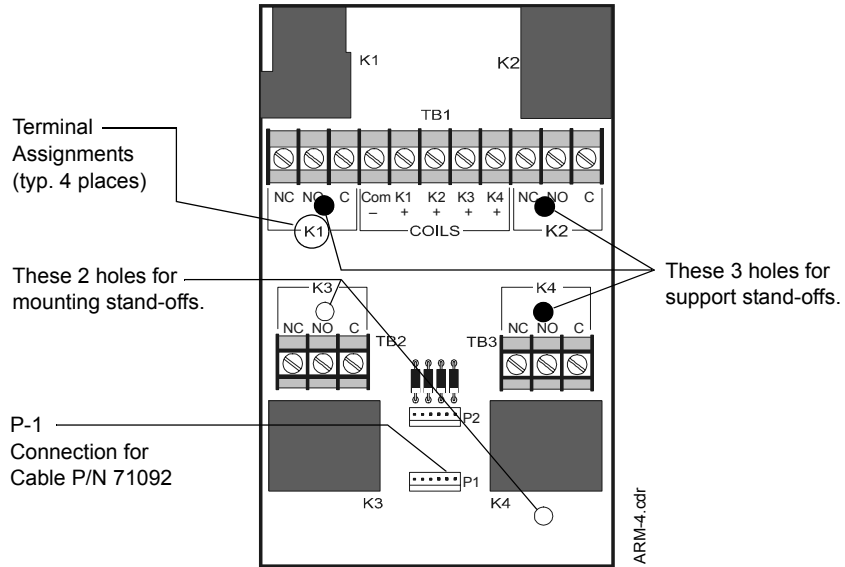
### 3.8.2 Installation

To install the Auxiliary Relay Module in the chassis:

1. Select a mounting position for the module on the chassis.
2. Install two (2) mounting stand-offs onto the studs of the chassis, at the selected location, as shown in Figure 12. Tighten securely.
3. Install three (3) support stand-offs, with screws, onto the PC board in the locations shown in Figure 12 or in the two right-hand positions on the first row. Tighten securely.
4. Position module over the stand-offs on the chassis; fasten the module to the chassis with the two (2) retaining screws. Tighten securely.
5. Connect one end of the Cable (P/N 71092) to plug P1 on the ARM-4.  
**Note:** The other end of the cable is connected to jumper JP5 on the CRM-4RK or CRE-4.
6. Connect all available external wiring at this time. Refer to Section 3.8.3 "Field Wiring an Auxiliary Relay Module".



**Figure 29 ARM-4 Stand-off & Terminal Locations**



### 3.8.3 Field Wiring an Auxiliary Relay Module

The figure above shows terminal assignments for ARM-4 module control relays K1-K4, which control nonpower-limited circuits. Power-limited and nonpower-limited circuit wiring must remain separated by at least 0.25 inch (6.35 mm) within the cabinet and exit the cabinet through different knockouts, conduits, or both.

**Note:** For more information, refer to Section 3.6 “UL Power-limited Wiring Requirements”.

The table contains contact ratings for relays K1-K4 on the ARM-4 module:

**Table 5 Contact Ratings for K1-K4 on the ARM-4 Module**

Resistive Load	Contacts	
	Normally Open (N.O.)	Normally Closed (N.C.)
125 VAC	20 A	10 A
30 VDC	20 A	10 A

## 3.9 Installing Remote Printers and/or CRT

### 3.9.1 Custom Cable Fabrication

A custom cable needs to be fabricated to connect the PRN-5 Printer, Keltron Printer or the CRT-2 Monitor to the system. Length of the cable will vary with each installation, but should not exceed a maximum length of 50 feet (15.24 meters). Printer must be installed in the same room as panel. Construct cable as follows:

1. Using overall foil/braided-shield twisted-pair cable, properly connect one end to the DB-25 Connector using the wiring specifications shown in the table below. (Custom cable kit P/N 90106 is provided.)
2. Tighten clamp on connector to secure cable.

<b>DB-25 Connector (Custom cable kit 90106)</b>	<b>TB14 on Control Panel</b>
Pin 3	TX
Pin 2	RX
Pin 7	REF

### 3.9.2 Installing and Configuring the PRN-5 Printer

When connected to the Control Panel via an EIA-232 interface, the PRN-5 prints a copy of all status changes within the control panel and time-stamps the printout with the time of day and date the event occurred. It provides 80 columns of data on standard 9" by 11" tractor-feed paper.

**Note:** You can also use the EIA-232 printer interface with UL-listed I.T.E. equipment, such as personal computers, to monitor the control panel for supplementary purposes.

This section contains information on connecting a printer to the control panel and for setting the printer options.

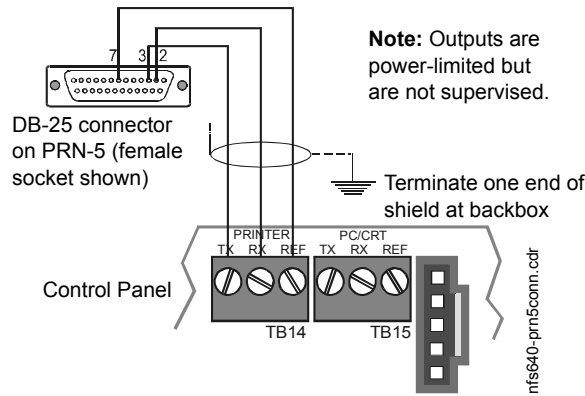
#### Connecting a Remote PRN Printer

Remote printers require a 120 VAC, 50/60 Hz primary power source. If required for the fire alarm system configuration (for example, a Proprietary Fire Alarm System), a remote printer requires a secondary power source (battery backup). Because a secondary power source is not provided, use a separate Uninterruptable Power Supply (UPS) that is UL-listed for Fire Protective Signaling. You may use your building emergency power supply, so long as it meets the power continuity requirements of NFPA 72. Refer to NFPA 72 for further details.

Connect the remote printer to the Control Panel as follows:

1. Connect the three (3) open leads of the custom cable to the TB14 terminal block on the control panel as shown in Figure 30.
2. Plug the DB-25 connector end of the custom cable into the EIA-232 port of the remote printer. Tighten securely.

**Figure 30 Remote Printer Connections**



### Setting Printer Options

Refer to the documentation supplied with the PRN-5 for instructions on using the printer menu controls. Set the printer options (under the menu area) according to the settings listed in Table 6.

**Table 6 PRN-5 Setup Options**

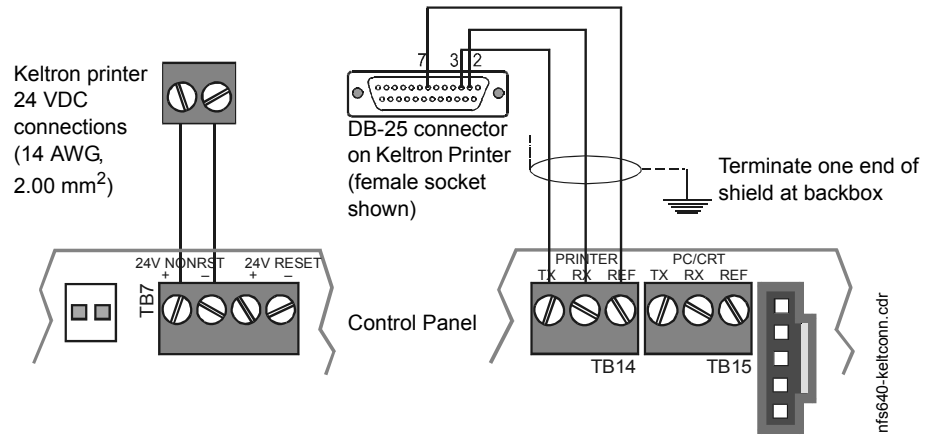
Option	Setting	Option	Setting
L/R Adjust	0	CPI	10 CPI
Font	HS Draft	Skip	0.5
LPI	6 CPI	Emulate	Epson
ESC Character	ESC	I/O	
Bidirectional Copy	ON	Buffer	36K
CG-TAB	Graphic	Serial	
Country	E-USE ASCII	Baud	9600
Auto CR	1S		2400
Color Option	Not Installed	Format	7 Bit, Even, 1 Stop
Formlen		Protocol	XON/XOFF
Lines	6 LPI-60	Character Set	Standard
Standard	Executive 10.5"	S1. Zero	On
		Auto LF	Off
		MENULOCK	
		PAPER	
		BIN 1	12/72"
		BIN 2	12/72"
		SINGLE	12/72"
		PUSH TRA	12/72"
		PULL TRA	12/72"
		PAP ROLL	12/72"
		PAPOPT	No

### 3.9.3 Installing and Configuring a Keltron Printer

Connect the remote printer to the Control Panel as follows:

1. Connect the three (3) open leads of the custom cable to the TB14 terminal block on the control panel as shown in the figure below.
2. Connect DC power from TB7 terminal block on the control panel as shown in the figure below.
3. Plug the DB-25 connector end of the custom cable into the EIA-232 port of the Keltron printer. Tighten securely.

**Figure 31 Keltron Printer Connections**



### Setting up the Keltron Printer

Set up a Keltron printer as follows:

1. The printer communicates using the following protocol:
  - Baud Rate: 9600
  - Parity: Even
  - Data bits: 7
2. Set the printer DIP switches SP1 and SP2 according to settings in the table below:

**Table 7 Keltron DIP Switch Settings**

SP1	On	Off
1		X
2		X
3		X
4	X	
5		X
6	X	
7	X	
8		X

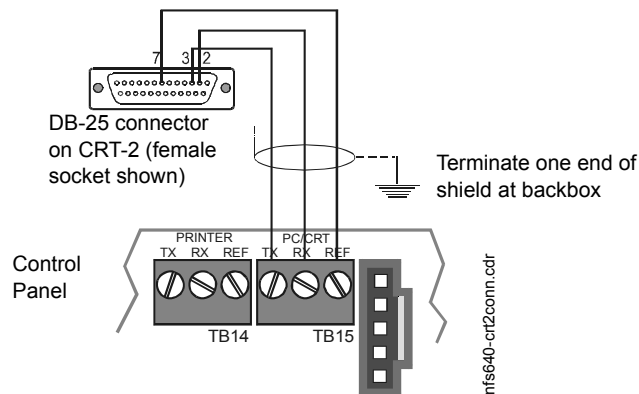
SP2	On	Off
1		X
2		X
3		X
4	X	
5		X
6		X
7	X	
8		X

### 3.9.4 Installing and Configuring a CRT-2

A CRT-2 can only be used in a non-networked application when used with the NFS-640. For further details on setting up the CRT-2, refer to the *NFS-640 Operations Manual*.

Connect a CRT-2 to the Control Panel as follows:

1. Connect the three (3) open leads of the custom cable to the TB15 terminal block on the control panel as shown in the figure below.
2. Plug the DB-25 connector end of the custom cable into the EIA-232 port of the CRT-2. Tighten securely.
3. Set parameters as discussed below.

**Figure 32 Connecting a CRT-2**

### Setting CRT-2 Parameters

The CRT-2 communicates with the control panel through a protocol defined by thirteen groups of parameters. To access a parameter group, press the corresponding function key (F1-F12) as shown in Table 8 below. You can then program parameters in each group.

Enter the CRT-2 setup menu by pressing and holding the <Ctrl> key while pressing the <Scroll Lock> key. Use arrow keys to move through the selections in each setup group; press the space bar to view the options for each parameter. When finished programming all setup groups, press the <Pause> key. To save all changes, press <Y>.

Table 8 shows the standard settings for using the CRT-2 with the NFS-640; for one instance where these settings may change slightly see Section 3.9.6 "Connecting Multiple Printers, CRTs, or CRT/PRN Combination". The basic settings for using the CRT-2 with NFS-640 are:

- Baud Rate 9600
- Data format 8 1 N
- Protocol xon/off.

**Note:** This section covers installation only; for information on how the CRT-2 functions as part of the fire alarm system, see the *NFS-640 Operations Manual*.

**Table 8 Standard CRT-2 Settings for Use with NFS-640**

Function Key	CRT-2 Parameters		
F1: Quick ("Read Status" key)	Emulation=CRT-2 Comm Mode=Full Duplex Enhanced=On	EIA Baud Rate=9600 Aux Baud Rate=9600 Language=U.S.	EIA Data Format=8/1/N Aux Data Format=8/1/N Host/Printer=EIA/Aux
F2: Genrl ("Alter Status" key)	Emulation=CRT-2 Auto Font Load=On Monitor Mode=Off Host/Printer=EIA/Aux	Enhanced=On Auto Page=Off Bell Volume=09	Auto Wrap=Off Auto Scroll=On Warning Bell=On
F3: Displ ("Prog" key)	Page Length=24 Display Cursor=On Columns=80 Scroll=Jump	Screen Length=26 Lines Cursor=Blink Line Width Change Clear=Off Refresh Rate=60 Hz	Screen Video=Normal Auto Adjust Cursor=On Speed=Normal Overscan Borders=Off
F4: Kybd ("Spl Funct" key)	Language=U.S. Keyclick=Off Key Lock=Caps	Char Set Mode=ASCII Key Repeat=Off Keyboard Present=Yes	Key Mode=ASCII Margin Bell=Off
F5: Keys ("Prior" key)	Enter Key=<CR> Alt Key=Meta Pound Key=U.S.	Return Key=<CR> Disconnect=Pause	Backspace=<BS>/<DEL> Desk Acc=Disabled
F6: Ports ("Next" key)	EIA Baud Rate=9600 Aux Baud Rate=9600 EIA Xmt=Xon-Xoff Aux Xmt=Xon-Xoff EIA Break=Off Aux Break=Off	EIA Data Format=8/1/N Aux Data Format=8/1/N EIA Recv=Xon-Xoff(XPC) Aux Recv=Xon-Xoff(XPC) EIA Modem Control=Off Aux Modem Control=Off	EIA Parity Check=On Aux Parity Check=On EIA Xmt Pace=Baud Aux Xmt Pace=Baud EIA Disconnect=2 sec Aux Disconnect=2 sec
F7: Host ("Auto Step" key)	Comm Mode=Full Duplex Recv <DEL>=Ignore Send Block Term=<CR>	Local=Off Send ACK=On Null Suppress=On	Recv <CR>=<CR> Send Line Term=<CR><LF>
F8: Print ("Activ Signal" key)	Pmnt Line Term=<CR><LF>	Pmnt Block Term=<CR>	Secondary Recv=Off
F9: Emul	Attribute=Page WPRT Intensity=Dim WPRT Blink=Off Status Line=Off	Bright Video=Off WPRT Reverse=Off Display NV Labels=Off Fkey Speed=Normal	Page Edit=Off WPRT Underline=Off Save Labels=On
F10	Setup Group F10 does not affect communications with the control panel.		
F11	Setup Group F11 does not affect communications with the control panel.		
F12: Prog ("Ack Step" key)	Program the function keys as follows: F1 ~A F2 ~B F3 ~C F4 ~D F5 ~E F6 ~F F7 ~G F8 ~H F9 ~I F10 ~J F11 ~K F12 ~L F13 ~M F14 ~N F15 ~O F16 ~P Shift F13 ~Q		

### 3.9.5 Connecting a PC

A PC can be hooked up to the Control Panel EIA-232 port to allow the VeriFire Tools programming utility to upload and download the operating program of the control panel. Refer to the insert in the VeriFire Tools CD and to the program's on-line help function for instructions.

**Note:** Download operations that change the basic program of the control panel must be performed by responsible service personnel in attendance at the control panel. After downloading a program, test the control panel in accordance with NFPA 72-1999.

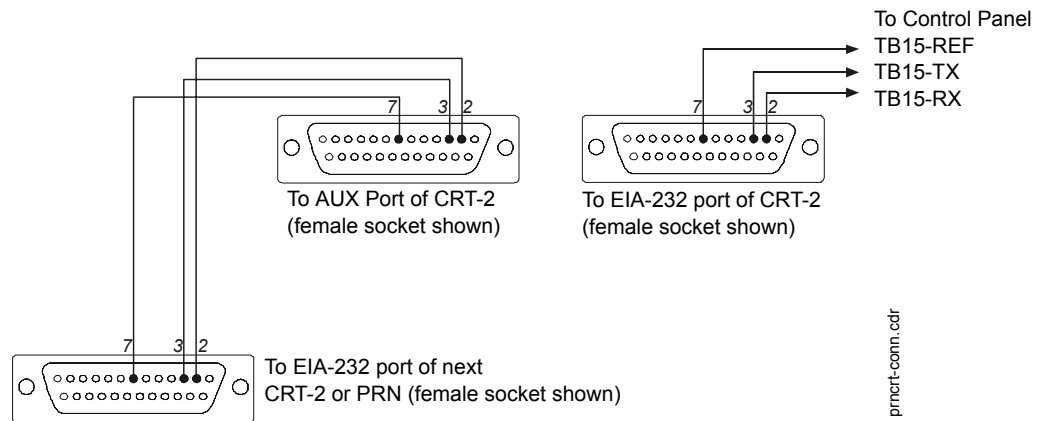
### 3.9.6 Connecting Multiple Printers, CRTs, or CRT/PRN Combination

Connecting multiple devices requires changing the CRT-2 setup using the F1(Quick) menu:

- Set Host/Printer=EIA/AUX.
- Set EIA Data Format=8/1/N.
- If the AUX device is a printer, set the Printer and AUX Data Format=7/1/E.
- If the AUX device is a second CRT-2, set the AUX Data Format=8/1/N.

Connect multiple devices as shown below:

**Figure 33 Connecting Multiple Devices on the EIA-232 Circuit**



Note: For wire requirements, see Table 16 in Appendix B "Electrical Specifications".

### 3.10 Wiring a Signaling Line Circuit (SLC)

#### Overview

Communication between the control panel and intelligent and addressable initiating, monitor, and control devices takes place through a Signaling Line Circuit (SLC). You can wire an SLC to meet the requirements of NFPA Style 4, Style 6, or Style 7 circuits. This manual provides requirements and performance details specific to this control panel; for installation information and general information, refer to the *SLC Wiring Manual*.

#### Wiring

Maximum wiring distance of an SLC using 12 AWG (3.1 mm<sup>2</sup>) wire:

- Style 4 -12,500 feet (3810 meters) total twisted-pair.
- Style 6 & 7 -10,000 feet (3048 meters) total twisted-pair.

#### Capacity

The NFS-640 provides one (1) SLC, with a total capacity of 318 intelligent/addressable devices:

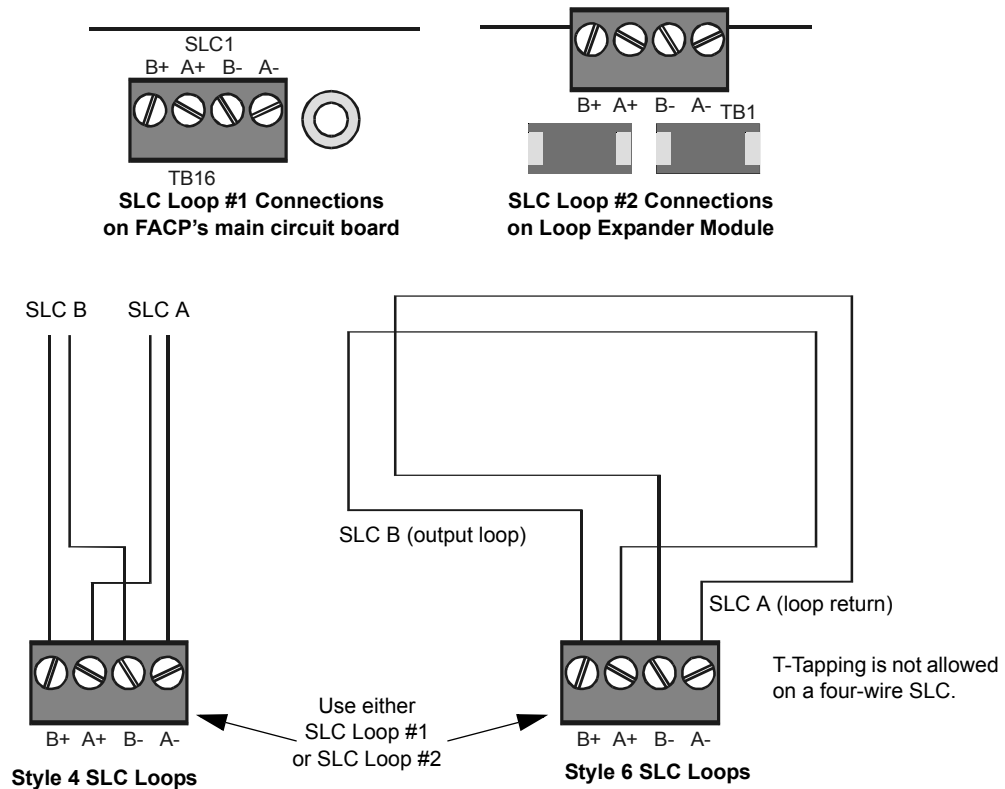
- 01-159 intelligent detectors
- 01-159 monitor and control modules

An optional expander board provides one (1) additional SLC, with the same capacity.

#### Installation

This control panel supports one or two SLC loops; a second SLC loop is obtained by installing an LEM-320 module. SLC loop #1 connects to TB16 on the control panel; SLC loop #2 connects to TB1 on the LEM-320. For details on designing, installing and configuring SLC loops, see the *SLC Wiring Manual*.

**Figure 34 SLC Loop Connections and Wiring**





# Section 4 Applications

## 4.1 Overview

Chapter	Covers the following topics
Section 4.2 “NFPA 72-1999 Central or Remote Station Fire Alarm System (Protected Premises Unit)”	How to install UDACT with the control panel for use as a NFPA Central or Remote Station Fire Alarm System (Protected Premises Unit)
Section 4.3 “NFPA 72-1999 Proprietary Fire Alarm Systems”	How to set up a Protected Premises Unit to communicate with a listed compatible Protected Premises Receiving Unit.
Section 4.4 “Fire/Security Applications”	How to use the control panel as a combination Fire/Security system, including the following: <ul style="list-style-type: none"><li>• Installing a Security Tamper Switch into the cabinet</li><li>• Circuit Wiring</li></ul>
Section 4.5 “Releasing Applications”	How to install the following releasing applications: <ul style="list-style-type: none"><li>• a Releasing Device to the Control Panel (NAC integral circuits)</li><li>• a Releasing Device to the FCM-1 Module</li><li>• an NBG-12LRA Agent Release-Abort Station</li></ul>

### **Municipal Box (Auxiliary)**

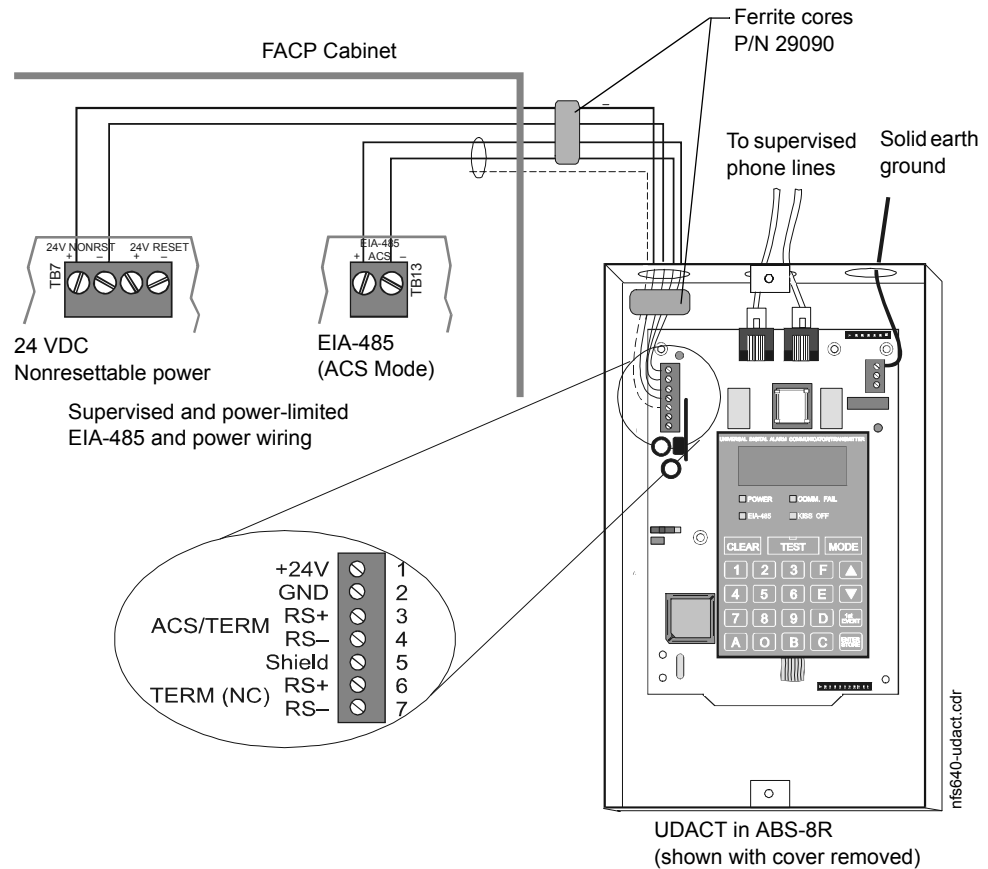
Municipal Box applications require a TM-4 Transmitter module. Refer to the *Transmitter Module TM-4* installation document for installation details.

## 4.2 NFPA 72-1999 Central or Remote Station Fire Alarm System (Protected Premises Unit)

Figure 35 shows typical wiring diagram for a NFPA 72-1999 Central Station Fire Alarm System (Protected Premises Unit) or a Remote Station Fire Alarm System (Protected Premises Unit) using the Universal Digital Alarm Communicator/Transmitter (UDACT) and control panel. This provides typical wiring only; connect and program the UDACT according to the directions given in the *UDACT Instruction Manual*.

**Note:** An NFPA 72-1999 Central Station requires 24 hours of standby power; an NFPA 72-1999 Remote Station requires 60 hours of standby power.

**Figure 35 Typical Wiring Diagram for a Central Station Fire Alarm System**



**Note:** Install a UL-listed 120 ohm End-of-Line resistor (P/N 71244) UDACT TB1 terminals 3 and 4 if this is the last or only device on EIA-485 line.

**Note:** This application can also be done with the TM-4 Transmitter; refer to the Transmitter Module TM-4 document for more details.

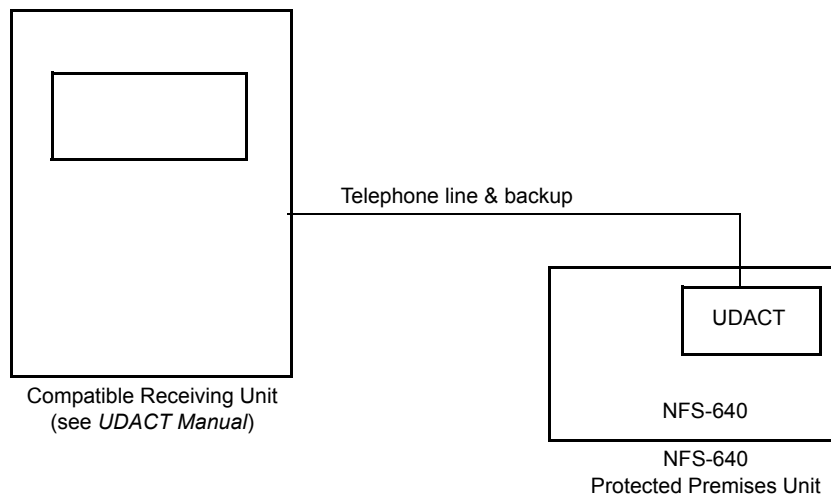
## 4.3 NFPA 72-1999 Proprietary Fire Alarm Systems

When connected and configured as a protected premises unit with UDACT, the NFS-640 will automatically transmit General Alarm, General Trouble, and General Supervisory signals to a listed compatible Protected Premises Receiving Unit. See the *UDACT Manual* for compatible receiving units. A simplified drawing of connections between a receiving unit and an NFS-640 protected premises unit is shown in Figure 36.

Connect the receiving unit to the protected premises unit as shown in Section 4.2 “NFPA 72-1999 Central or Remote Station Fire Alarm System (Protected Premises Unit)”.

For information on installing and programming the Receiving unit, refer to the documentation for that control panel.

**Figure 36 Typical Proprietary Fire Alarm Systems Wiring Connections**



## 4.4 Fire/Security Applications

**Note:** NFS-640 is not approved for use in security applications in Canada.

### 4.4.1 General Operation

The control panel can be used as a combination Fire/Security system when installed and operated according to the instructions in this section.

For security applications, program one or more monitor module (listed for security applications) with the SECURITY Type Code, and wire as shown in Figure 38. Activating this type of module lights the SECURITY LED, and displays a security alarm condition on the control panel LCD display. The panel sounder will sound until the Security alarm is acknowledged. You can also program additional sounders or output devices to activate with the security alarm initiating device. The SECURITY Type Code is designed to indicate an alarm as follows: (a) on an open or short circuit; or (b) on a  $\pm 50\%$  change in resistance value from the End-of-Line resistor value.

A tamper switch installed in the cabinet door will indicate a door tamper condition whenever the door is open. If the control panel indicates a Security alarm, you can acknowledge, silence, and reset the condition from the control panel.

When the system resets, a 30-second exit timer starts. During this time the tamper switch and all Security alarms are ignored. There is no entrance delay timer.

For bypass of security zones, use the DISABLE routine (covered in the *Status Change* section of the *NFS-640 Operations Manual*) for Security type devices.

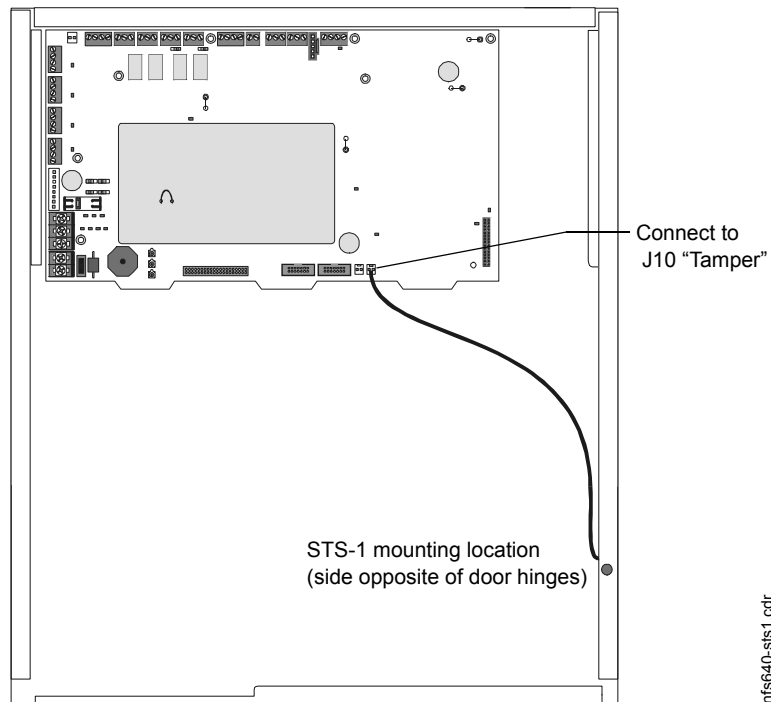


**WARNING: Damage can result from incorrect wiring connections.**

## 4.4.2 Installing a Security Tamper Switch

Follow the instructions below to wire the cabinet with a Security Tamper Switch kit model STS-1.

**Figure 37 Installing the STS-1 Security Tamper Switch**



Step	Action
1	Install the STS-1 Tamper Switch onto the side of the backbox opposite the door hinge, pushing the switch through the opening until it snaps into place.
2	Install the magnet on the same side of the cabinet door as the lock. Push the magnet through the opening in the door until it snaps into place.
3	Connect the STS-1 connector to J10 (Tamper) on the Control Panel.

## 4.4.3 Receiving Unit

For applications requiring transmission of security alarm information to a central receiving unit, the control panel may be connected via a UDACT to a compatible receiving unit (see the *UDACT Manual*). For information on configuring the Receiving unit for Combination Fire/Security applications, refer to the documentation for that control panel.

#### 4.4.4 Programming

The control panel can communicate with any number of security devices. To do so, program the points as follows:

1. Select the address of the module(s) to be used for security.
2. Select the Type Code SECURITY.

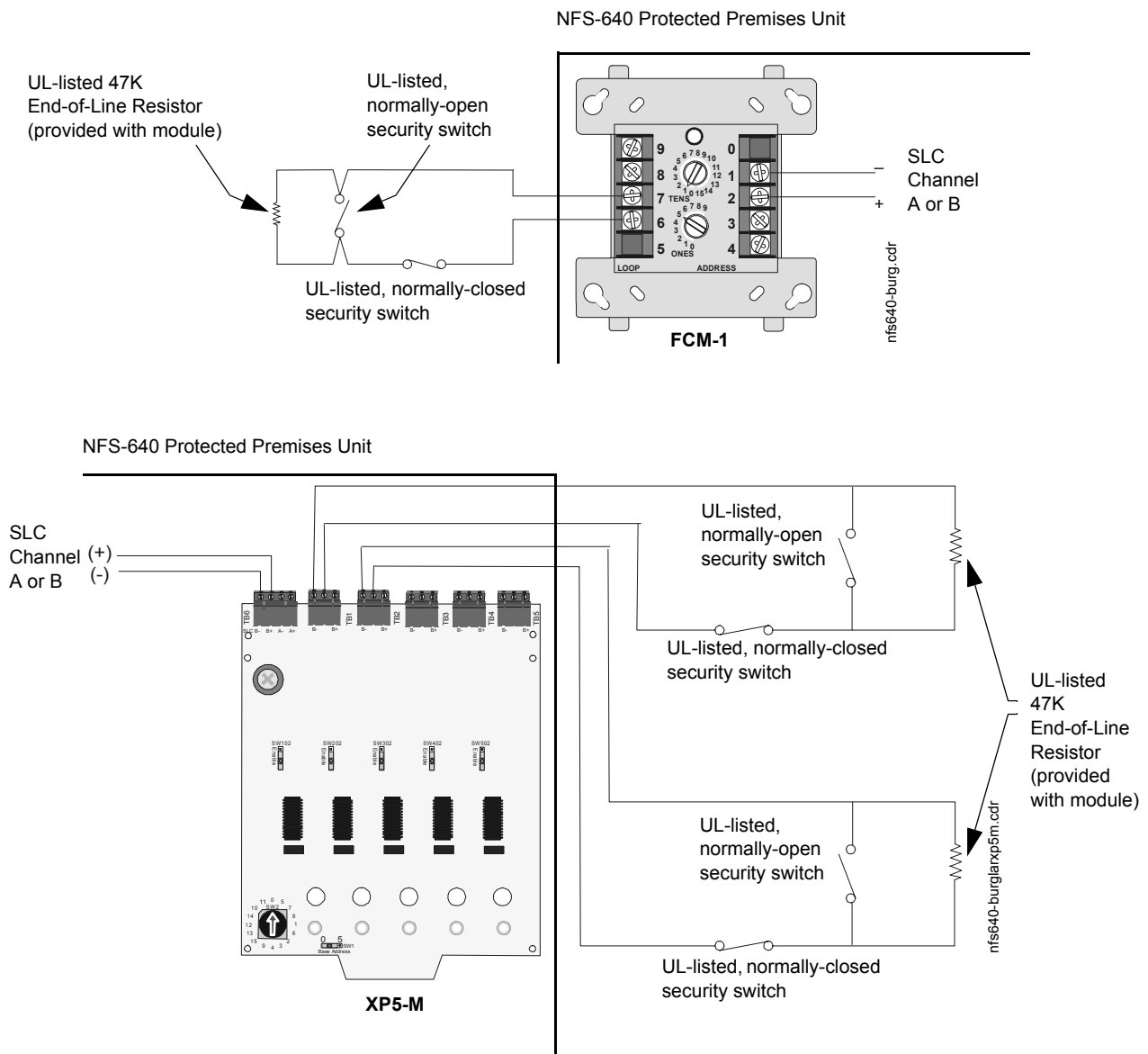
**Note:** For detailed instruction on programming Type Codes, refer to the *NFS-640 Programming Manual*.

### 4.4.5 Wiring for Proprietary Security Alarm Applications


Typical wiring for proprietary security alarm applications with FCM-1 modules or XP5-M modules. Note the following:


- The module is programmed with software SECURITY Type Code.
- Supplementary use only applies to UL-listed systems.
- NAC devices used for security cannot be shared with fire NAC devices.
- Refer to the *Device Compatibility Document* for compatible NAC devices.
- All monitor modules used for security application must be installed in the NFS-640 cabinet with STS-1 Security Tamper Switch.

**Figure 38 Wiring Diagram for Proprietary Security Alarm Applications**



## 4.5 Releasing Applications

 **WARNING:** When used for CO<sub>2</sub> releasing applications, observe proper precautions as stated in NFPA 12. Do not enter the protected space unless physical lockout and other safety procedures are fully completed. Do not use software disable functions in the panel as lockout.

 **WARNING:** Do not enable the BACKUP option switch for any of the four Notification Appliance Circuits (NACs) if they are used for releasing functions!

### 4.5.1 Overview

This control panel can be used for agent release or preaction/deluge control applications. In a properly configured system with compatible, listed actuating and initiating devices, this control panel complies with the following NFPA standards for installation in accordance with the acceptable standard:

**Table 9 NFPA Standards for Releasing Applications**

Standard	Covers
NFPA 12	CO <sub>2</sub> Extinguishing Systems
NFPA 12A	Halon 1301 Extinguishing Systems
NFPA 13	Sprinkler Systems
NFPA 15	Water Spray Systems
NFPA 16	Foam-Water Deluge and Foam-water Spray Systems
NFPA 17	Dry Chemical Extinguishing Systems
NFPA 17A	Wet Chemical Extinguishing Systems
NFPA 2001	Clean Agent Fire Extinguishing Systems

### 4.5.2 Programming

The control panel supports up to ten releasing software zones. You can map these zones to activate Control Panel releasing outputs and FCM-1 modules. Program the FCM-1 module for the appropriate type code according to the chart below:

**Table 10 Type Codes for Releasing Applications**

Type Code: RELEASE CKT <ul style="list-style-type: none"> <li>• For use in UL applications.</li> <li>• Do not use REL device at the solenoid.</li> <li>• Cannot use power-limited wiring.</li> <li>• Supervised for open circuit only.</li> <li>• Supervised for power loss with power-supervision relay.</li> </ul>	Type Code: REL CKT ULC <ul style="list-style-type: none"> <li>• For use in UL or ULC applications.</li> <li>• Requires REL device at solenoid.</li> <li>• Power-limited wiring.</li> <li>• Supervised for open circuit and shorts.</li> <li>• Supervised for power loss with power-supervision relay.</li> </ul>
--	--

For more information, refer to the *NFS-640 Programming Manual*.

### 4.5.3 Wiring

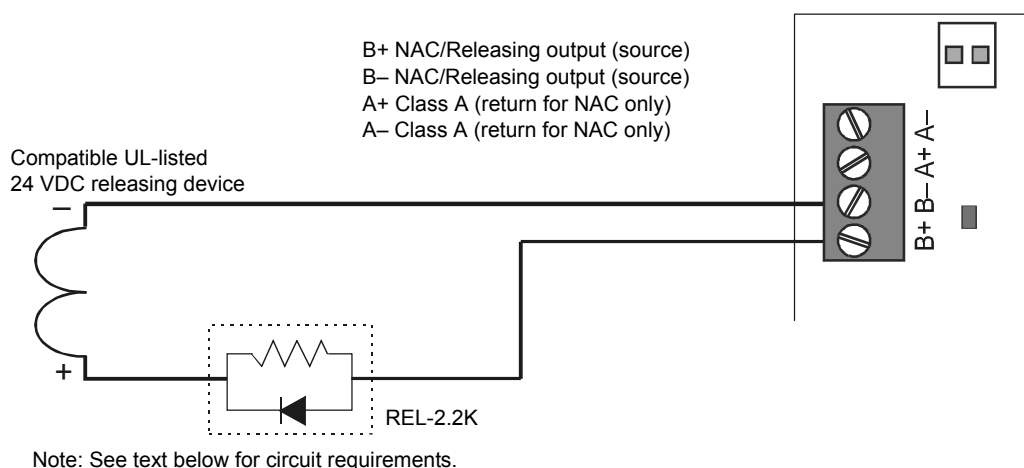
References to wiring diagrams for releasing applications:

To connect	Refer to
A releasing device to the control panel.	Section 4.5.4 “Connecting a Releasing Device to the Control Panel”.
A releasing device to the FCM-1 Module.	Section 4.5.5 “Connecting a Releasing Device to the FCM-1 Module”.
An NBG-12LRA Agent Release-Abort Station.	Section 4.5.6 “Connecting an NBG-12LRA Agent Release-Abort Station”.

### 4.5.4 Connecting a Releasing Device to the Control Panel

Use TB3 (NAC#4), TB4 (NAC#3), TB5 (NAC#2), or TB6 (NAC#1) on the control panel for NAC/Releasing Circuits. Only one releasing device can be installed per NAC.

**Figure 39 Typical Style 4 Connection of a Releasing Device to Control Panel**



**WARNING: Do not enable the BACKUP option switch for any of the four Notification Appliance Circuits (NACs) if they are used for releasing functions!**

**Circuit Requirements.** When connecting a releasing device, note the following:

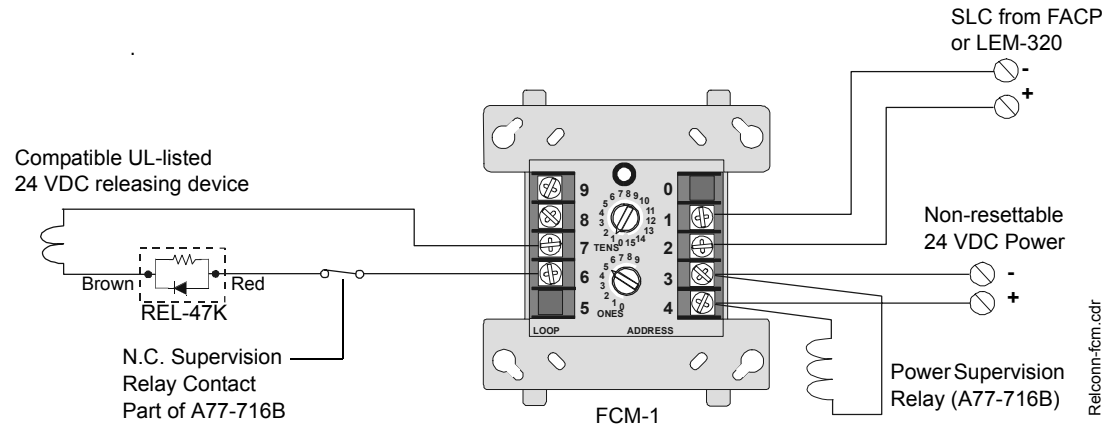
1. The control panel provides four NAC/Releasing Circuits (Style Y or Z). Each circuit can provide 2.5 A. Total current drawn from the power supply cannot exceed 6 A in an alarm condition (refer to Table 12, “System Draw Current Calculations,” on page 71). Use UL-listed 24 VDC appliances only.
2. Circuits are supervised and power-limited (except if configured according to Note 4a below). For more information, refer to the *Device Compatibility Document*.
3. For NFPA 13 and 15 applications, disable the Soak Timer (Soak=0000); for NFPA 16 applications, set the Soak Timer (0600-0900 seconds). Refer to the *NFS-640 Programming Manual* for instructions on setting the Soak Timer.
4. In applications not requiring power-limited circuits –
  - a) If the application does not require supervising the releasing device against shorts, End-of-Line devices (P/N REL-2.2K) are not required;
  - b) Limited energy cable cannot be used for wiring of a releasing device circuit;
  - c) Maintain a 0.25 inch (6.35 mm) spacing between the releasing circuit device wiring and any power-limited circuit wiring; and
  - d) Program the releasing circuit for Type Code RELEASE CKT.
5. The releasing circuit must be programmed with a releasing type code listed in the *NFS-640 Programming Manual*.



### 4.5.5 Connecting a Releasing Device to the FCM-1 Module

The module can control 1 A of current. Make sure to keep total system current within the limits of the power supply. You can power the module from the power supply of the Control Panel or any UL -listed 24 VDC regulated power-limited power supply for Fire Protective Signaling. For more information, refer to the *Device Compatibility Document*.

**Figure 40 Typical Connection of a 24 VDC Releasing Device to the FCM-1 Module**



Note: See preceding text for circuit requirements.

**Circuit Requirements.** When connecting a releasing device to the FCM-1 module, note the following:

1. For NFPA 13 and 15 applications, disable the Soak Timer (Soak=0000); for NFPA 16 applications, set the Soak Timer (0600-0900 seconds). Refer to the *NFS-640 Programming Manual* for instructions on setting the Soak Timer.
2. Circuits are supervised and power-limited (except if configured according to Note 3a below).
3. In applications not requiring power-limited circuits –
  - a) If the application does not require supervising the releasing device against shorts, End-of-Line devices (P/N REL-47K) are not required
  - b) Limited energy cable cannot be used for wiring of a releasing device circuit;
  - c) Maintain a 0.25 inch (6.35 mm) spacing between the releasing circuit device wiring and any power-limited circuit wiring; and
  - d) Program the releasing circuit for Type Code RELEASE CKT.
4. The FCM-1 module must be programmed with a releasing type code listed in the *NFS-640 Programming Manual*.



# Section 5 Testing the System

## 5.1 Acceptance Test

When finished with the original installation and all modifications, conduct a complete operational test on the entire installation to verify compliance with applicable NFPA standards. Testing should be conducted by a factory-trained fire alarm technician in the presence of a representative of the Authority Having Jurisdiction and the owner's representative. Follow procedures outlined in NFPA Standard 72-1999, Chapter 7, *Inspection, Testing and Maintenance*.

## 5.2 Periodic Testing and Service

Periodic testing and servicing of the control panel, all initiating and notification devices, and any other associated equipment is essential to ensure proper and reliable operation. Test and service the control panel according to the schedules and procedures outlined in the following documents:

- NFPA Standard 72-1999, Chapter 7, *Inspection, Testing and Maintenance*.
- Service manuals and instructions for the peripheral devices installed in the system. Correct any trouble condition or malfunction immediately.

## 5.3 Operational Checks

Between formal periodic testing and servicing intervals, the following operation checks should be performed monthly, or more frequently when required by the Authority Having Jurisdiction.

- Check that the green POWER LED lights.
- Check that all status LEDs are off.
- Press and hold the LAMP TEST key. Verify that all LEDs and all LCD display segments work.
- Before proceeding: a) notify the fire department and the central alarm receiving station if transmitting alarm conditions; b) notify facility personnel of the test so that alarm sounding devices are disregarded during the test period; and c) when necessary, disable activation of alarm notification appliances and speakers to prevent their sounding.
- Disconnect all releasing devices to prevent accidental activation.



**WARNING: Do not rely on disable/enable software settings to lockout releasing devices.**

- Activate an Initiating Device Circuit using an alarm initiating device or an addressable initiating device on the SLC and check that all programmed active notification appliances function. Reset the alarm initiating device, the control panel, and any other associated equipment. In voice alarm applications, confirm that the proper tone(s) and/or messages sound during alarm conditions. Select the paging function and confirm that the message can be heard in the affected fire zones. Repeat the above step with each Initiating Device Circuit and each addressable device.
- On systems equipped with a fire fighter's telephone circuit, make a call from a telephone circuit and confirm a ring tone. Answer the call and confirm communication with the incoming caller. End the call and repeat for each telephone circuit in the system.
- Remove AC power, activate an Initiating Device Circuit through an alarm initiating device or an addressable initiating device on the SLC, and check that programmed active notification appliances sound, and alarm indicators illuminate. Measure the battery voltage with notification appliances active. Replace any battery with a terminal voltage less than 21.6 VDC and reapply AC Power.

**Note:** The battery test requires fully charged batteries. If batteries are new or discharged due to a recent power outage, allow the batteries to charge for 48 hours before testing.

*continued...*

- Return all circuits to their pretest condition.
- Check that all status LEDs are off and the green POWER LED is on.
- Notify fire, central station and/or building personnel when you finish testing the system.

## 5.4 Battery Checks and Maintenance

Maintenance-free sealed lead-acid batteries used in the system do not require the addition of water or electrolyte. These batteries are charged and maintained in a fully charged state by the main power supply's float charger during normal system operation. A discharged battery typically charges at 1.5–1.8 A and reaches the float voltage of 27.6 VDC within 48 hours.

Follow the local AHJ and manufacturer recommendations for battery replacement intervals. Minimal replacement battery capacity appears on the control panel marking label. Immediately replace a leaking or damaged battery. You can get replacement batteries from the manufacturer.



**WARNING: Batteries contain Sulfuric Acid which can cause severe burns to the skin and eyes and damage to fabrics.**

- If a battery leaks and contact is made with the Sulfuric Acid, immediately flush skin and/or eyes with water for at least 15 minutes. Water and household baking soda provides a good neutralizing solution for Sulfuric Acid.
- If Sulfuric Acid gets into eyes, seek immediate medical attention.
- Ensure proper handling of the battery to prevent short circuits.
- Take care to avoid accidental shorting of the leads from uninsulated work benches, tools, bracelets, rings, and coins.



**WARNING: Shorting the battery leads can damage the battery, equipment, and could cause injury to personnel.**

### On-board Memory-Backup Battery

A snap-in lithium battery on the CPU provides backup of the CPU's on-board memory during power loss. The expected shelf-life for this battery is 10+ years. However if battery connections are damaged or the battery does lose power, a system trouble message will appear: "Bat. Backup RAM".

# Appendix A Power Supply Calculations

Calculations must be done to determine standby and alarm DC current loads. Ampere-hour requirements must be calculated as well to determine battery size.

The on-board power supply provides filtered 24VDC power that may be used for operating external devices. Use Table 12 to determine if external loading is within the capabilities of the power supply.

## A.1 Calculating AC Branch Circuit Current

Use the table below to determine the total amount of current, in AC amperes, that a 120 VAC, 50/60 Hz service must be able to supply to the fire alarm system. Devices rated for 240 VAC operation will draw approximately one-half the current listed in Table 11.

**Table 11 120 VAC Fire Alarm Circuit**

Device Type	No. of Devices		Current (amps)		Total Current
Main Power Supply	[ 1 ]	X	3.0	=	3.0
AA-30	[ ]	X	1.00	=	
AA-120	[ ]	X	1.85	=	
ACPS-2406	[ ]	X	2.7 <sup>1</sup>	=	
APS-6R	[ ]	X	2.5	=	
CHG-120	[ ]	X	2.0	=	
Sum column for AC Branch Current required=amps					

1. Separate calculations are required for any devices powered by the ACPS-2406. It has its own integral battery charger and batteries can be connected directly to it. Refer to the *ACPS-2406 Installation Manual* for its battery calculations.

### AC Branch Circuit Installation

For guidelines on wiring the AC branch circuit current, see “Operating Power: AC Branch Circuit” on page 77 in Appendix B.1 “Electrical Specifications”.

## A.2 Calculating the System Current Draws

The control panel’s main power supply must be able to power all internal system devices (and several types of external devices) continuously during non-fire alarm conditions. Use column 1 in Table 12 to calculate the Non-Fire Alarm Load on the power supply regulator when applying primary power. The main power supply must also provide a finite amount of additional current during a fire alarm condition. Use column 2 in Table 12 to calculate the additional current needed during fire alarms. The requirements for non-fire alarm and fire alarm current loads cannot exceed the capabilities of the power supply as listed below:

- 3 A at 24 VDC during Standby; and
- 6 A at 24 VDC during Alarm.

### How to Use the Calculating Tables

As used in this section, “Primary” refers to the control panel’s on-board power supply, its primary source of AC power. “Secondary” refers to the control panel’s backup batteries (or any other 24 VDC power supply listed for Fire Protective Signaling and connected in place of the batteries). The term

“standby” refers to the output current required when no fire alarm is present. The term “alarm” refers to the output current required when a fire alarm is present.

The Primary Power Source Non-Alarm Current and Alarm Current columns are DC current calculations. These calculations confirm that the power supply can provide enough current to support the system during Primary Non-Fire Alarm and Fire Alarm conditions.

**Quantities.** List the number of devices powered by the Panel Output (TB2) and the Accessories Output (TB6). Devices powered by the Accessories Output draw current directly from the panel. Devices powered by the Panel Output draw current through the fire panel’s connection to the power supply. Use these quantities to calculate total current draw of each set of devices in calculation columns 1, 2, and 3.

**Calculation Column 1 (Primary, Non-Fire Alarm Current in amps).** Add the contents of calculation column 1 to get the current drawn from the power supply during a non-alarm condition, with AC power applied. This current draw cannot exceed 3 A without an auxiliary power supply.

**Calculation Column 2 (Primary, Fire Alarm Current in amps).** Calculation column 2 lets the system designer determine the current load that the power supply must support during a fire alarm. The total current draw during a fire alarm cannot exceed 6 A without an auxiliary power supply.

Typically, a system should contain capacity to activate all output circuits and relays, and support fire alarms on no less than 10% of Initiating Device Circuits, subject to the requirements of the Authority Having Jurisdiction (AHJ).

The Control Panel provides power for Notification Appliance Circuits. Refer to the Device Compatibility Document for 24 VDC notification appliances that are UL- and ULC-listed for fire alarm systems.

**Calculation Column 3 [Secondary (Battery) Non-Alarm Current].** Column 3 lets the system designer calculate the non-fire alarm current drawn from the secondary source in a non-fire alarm condition during AC power loss. The non-fire alarm current is required to complete the standby battery calculations. After summing all current draws, insert the total in Table 13.

**Table 12 System Draw Current Calculations**

Category	Calculation Column 1 Primary, Non-Fire Alarm Current (amps)			Calculation Column 2 Primary, Fire Alarm Current (amps)			Calculation Column 3 Secondary, Non-Fire Alarm Current (amps)		
	Qty	X [current draw]=	Total	Qty	X [current draw]=	Total	Qty	X [current draw]=	Total
CPU-640	1	x [0.230]=		1	x [0.230]=		1	x [0.230]=	
KDM-2	[ ]	x [0.094]=		[ ]	x [0.094]=		[ ]	x [0.040]=	
LEM-320	0 / 1	x [0.100]=		0 / 1	x [0.100]=		0 / 1	x [0.100]=	
SLC loop <sup>1</sup> : with jumper JP12 cut on CPU or without jumper JP12 cut on CPU	0/1/2	x [0.200]= x [0.400]=		0/1/2	x [0.200]= x [0.400]=		0/1/2	x [0.200]= x [0.400]=	
NCA (back light on)	[ ]	x [0.400]=		[ ]	x [0.400]=		[ ]	x [0.400]=	
NCM-W, NCM-F	[ ]	x [0.110]=		[ ]	x [0.110]=		[ ]	x [0.110]=	
TM-4	[ ]	x [0.110]=		[ ]	x [0.175]=		[ ]	x [0.110]=	
DPI-232 (Refer to Doc. 51499)	[ ]	x [ ]=		[ ]	x [ ]=		[ ]	x [ ]=	
APS-6R ACPS-2406							[ ]	x [0.025]= x [0.0013]=	
ICM-4RK, ICM-4, CRM-4, CRM-4RK	[ ]	x [0.007]=		[ ]	x [0.072]=		[ ]	x [0.007]=	
ICE-4	[ ]	x [0.001]=		[ ]	x [0.065]=		[ ]	x [0.001]=	
CRE-4		N/A			x [0.065]=			N/A	
DCM-4RK, DCM-4	[ ]	x [0.008]=		[ ]	x [0.080]=		[ ]	x [0.008]=	
VCE-4	[ ]	x [0.001]=		[ ]	x [0.040]=		[ ]	x [0.001]=	
VCM-4RK, VCM-4	[ ]	x [0.007]=		[ ]	x [0.040]=		[ ]	x [0.007]=	
ARM-4 Auxiliary Relay				[ ]	x [0.146]=				
AA-30 AA-100, AA-120							[ ]	x [0.045]= x [0.050]=	
ACM-24AT	[ ]	x [0.016]=		[ ]	x [0.070]=		[ ]	x [0.016]=	
ACM-48A	[ ]	x [0.016]=		[ ]	x [0.070]=		[ ]	x [0.016]=	
AEM-24AT	[ ]	x [0.002]=		[ ]	x [0.056]=		[ ]	x [0.002]=	
AEM-48A	[ ]	x [0.002]=		[ ]	x [0.056]=		[ ]	x [0.002]=	
Maximum number of LEDs illuminated on these annunciators during non-fire conditions:	[ ]	x [0.0054]=					[ ]	x [0.0054]=	
AFM-16AT, AFM-32A	[ ]	x [0.040]=		[ ]	x [0.056]=		[ ]	x [0.040]=	
ACM-16AT, ACM-32A	[ ]	x [0.040]=		[ ]	x [0.056]=		[ ]	x [0.040]=	
AEM-16AT, AEM-32A	[ ]	x [0.002]=		[ ]	x [0.018]=		[ ]	x [0.002]=	
AFM-16A	[ ]	x [0.025]=		[ ]	x [0.065]=		[ ]	x [0.025]=	
LCD-80, LCD-80TM	[ ]	x [0.100]=		[ ]	x [0.100]=		[ ]	x [0.050]=	
<b>ACM-8R (refer to Doc. 15342)</b>	[ ]	x [ ]=		[ ]	x [ ]=		[ ]	x [ ]=	
<b>LDM (refer to Doc. 15885)</b>	[ ]	x [ ]=		[ ]	x [ ]=		[ ]	x [ ]=	
UZC-256	[ ]	x [0.035]=		[ ]	x [0.085]=		[ ]	x [0.035]=	
AMG-1, AMG-E	[ ]	x [0.060]=		[ ]	x [0.060]=		[ ]	x [0.060]=	
FFT-7, FFT-7S	[ ]	x [0.060]=		[ ]	x [0.120]=		[ ]	x [0.060]=	
RM-1	[ ]	x [0.020]=		[ ]	x [0.020]=		[ ]	x [0.020]=	
FZM-1, MMX-2	[ ]	x [0.0094]=		[ ]	x [0.090]=		[ ]	x [0.0094]=	
<b>XPIQ (Refer to Doc. 51013)</b>	[ ]	x [ ]=		[ ]	x [ ]=		[ ]	x [ ]=	
RPT-W, RPT-WF, RPT-F RPT-485W, RPT-485WF	[ ]	x [0.017]=		[ ]	x [0.017]=		[ ]	x [0.017]=	
RFX (Refer to Doc. 51012)	[ ]	x [ ]=		[ ]	x [ ]=		[ ]	x [ ]=	
UDACT Communicator	[ ]	x [0.040]=		[ ]	x [0.100]=		[ ]	x [0.040]=	
VEC-25/50	[ ]	x [0.215]=		[ ]	x [1.215]=		[ ]	x [0.215]=	
with optional FC-AAM25	[ ]	x [0.245]=		[ ]	x [2.215]=		[ ]	x [0.245]=	
<b>Four-Wire Smoke Detectors<sup>2</sup></b>	[ ]	x [ ]=		[ ]	x [ ]=		[ ]	x [ ]=	
	[ ]	x [ ]=		[ ]	x [ ]=		[ ]	x [ ]=	
Power Supervision Relay (A77-716B)	[ ]	x [0.020]=		[ ]	x [0.020]=		[ ]	x [0.020]=	
Notification Appliance powered from Main Power Supply <sup>3</sup>				[ ]	x [ ]=		[ ]	x [ ]=	
<b>DHX-501, FSD-751RP, FSD-751RPL (Duct Detectors with internal relays) Refer to installation document</b>	[ ]	x [ ]=		[ ]	x [ ]=		[ ]	x [ ]=	
	[ ]	x [ ]=		[ ]	x [ ]=		[ ]	x [ ]=	
CHG-120 Battery Charger							[ ]	x [0.060]=	
<b>Local Energy Municipal Box</b>				[ ]	x [ ]=				
<b>Compatible Devices not listed above<sup>4</sup></b>	[ ]	x [ ]=		[ ]	x [ ]=		[ ]	x [ ]=	
	[ ]	x [ ]=		[ ]	x [ ]=		[ ]	x [ ]=	
Sum each column for totals		Primary, non-alarm:		Primary, alarm:		Secondary, non-alarm:			

1. Value represents an SLC's maximum current draw. Refer to device datasheets for individual current draws. If jumper JP12 is cut, total device current cannot exceed 200 mA; if jumper JP12 is not cut, total device current cannot exceed 400 mA.
2. The total regulated load current supplied to four-wire smoke detector and power supervision relays cannot exceed 1.25 A.
3. Enter the total notification appliance draw from the Main Power Supply, excluding the current from APS-6R supplies. Refer to Device Compatibility Document.
4. Refer to manual and/or Device Compatibility Document.

## A.2.1 Calculating the Maximum Secondary Power Fire Alarm Current Draw

Use the table below to determine the maximum current requirements of secondary power source during fire alarm conditions. The result obtained is the amount of current that the batteries must be able to supply to the fire alarm system. Use the result in Table 14 to determine the size of the batteries needed for the fire alarm system.

Results taken from the table below assume that, while in a fire alarm condition, batteries must feed the main power supply (and any additional supplies such as the APS-6R and AA-30) with the maximum rated power each supply can provide.

**Note:** The Secondary Fire Alarm Load cannot exceed the following:

- 9 A with PS-12120 batteries.
- 12 A with PS-12250 batteries.
- 20 A with PS-12550 batteries.

**Table 13 Maximum Secondary Power Fire Alarm Current Draw**

Device	Quantity		Current (in amps)	Total Current/ Type
Alarm Current, from Table 12, col 2			=	
APS-6R <sup>1</sup>	[ ]	X	6	=
AA-30 <sup>2</sup>	[ ]	X	3	=
AA-120 <sup>2</sup>	[ ]	X	7.3	=
Sum Column for Secondary Fire Alarm Load			=	

1. Actual load current may be used in place of maximum rated supply current. To calculate actual load current, sum the current draws for each appliance connected to APS-6R supplies.
2. Exclude Amplifiers that are employed for backup.

Contact rating (maximum current) for battery-switching relay in the control panel



## A.3 Calculating the Battery Requirements

### A.3.1 Calculating the Battery Capacity

Use this table to determine the battery capacity needed for the system:

**Table 14 Secondary Power Standby and Fire Alarm Load**

<b>Current (amps)</b>	<b>X</b>	<b>Time (hours)</b>	<b>= AH</b>
Secondary Non-Fire Alarm Current (from column 3 in Table 12)		Required Secondary Non-Fire Alarm Standby Time (24 or 60 hours)	
_____	X	_____	= _____ AH
APS-6R Standby Load Current		Required Secondary Non-Fire Alarm Standby Time (24 or 60 hours)	
_____	X	_____	= _____ AH
Secondary Fire Alarm Load (from Table 13)		Required Fire Alarm Standby Time: (for 5 minutes, enter 0.084; for 15 minutes, enter 0.25)	
_____	X	_____	= _____ AH
Sum Column for Total Secondary Amp Hours calculated			= _____ AH
Multiply by the derating factor x 1.2 (see Note 7)			= _____ AH
Battery Size – Total Secondary Amp Hours Required			= _____ AH

The following notes apply to Table 14:

- NFPA 72-1999 Local, Proprietary, and Central Station systems requires 24 hours of standby power followed by 5 minutes in alarm.
- NFPA 72-1999 Auxiliary and Remote Station Systems require 60 hours of standby power followed by 5 minutes in alarm.
- Batteries installed in a system powered by an automatic starting engine generator need to provide at least 4 hours of standby power.
- Factory Mutual requires 90 hours of standby for deluge-preaction systems.
- Emergency voice/alarm communications systems require 2 hours of operation in the alarm condition. Due to the sporadic nature of voice operation, however, NFPA 72-1999 permits 15 minutes of operation at a maximum connected load to equal 2 hours of normal use.
- If the total exceeds 25 AH, the system requires a separate NFS-LBB battery enclosure for two PS-12550, 55 AH batteries in a separate NFS-LBB enclosure. If the total exceeds 55 AH, the system requires an auxiliary battery charger with sufficient amp-hour capacity; this charger must be UL-listed for Fire-Protective Signaling. If CHG-120 battery charger is used, it requires a second NFS-LBB enclosure.
- The following battery derating factors must be used for Canadian installations using NFS-640 charger:
  - For a 12 AH battery, use derating factor of 1.2
  - For a 25 AH battery, use derating factor of 1.5
  - For a 55 AH battery, use derating factor of 1.8

When batteries are charged by CHG-120 charger use a derating factor of 1.2 for 25 AH and 55 AH batteries.

### A.3.2 Calculating the Battery Size

Use this table to choose the battery size, in amp-hours, needed to support the fire alarm system. Select batteries that meet or exceed the Total Amp-Hours calculated in Table 14 and that are within the acceptable battery charger range (12-55 AH). Write the amp-hours requirements on the Protected Premises label.

**Table 15 Selecting the Battery Size**

<b>Battery Size</b>	<b>Voltage Rating</b>	<b>Number Required</b>	<b>Part Number</b>	<b>Backbox Size</b>
12 AH	12 volts	two	PS-12120	SBB-A4*, SBB-B4*, SBB-C4*, SBB-D4*
25 AH	12 volts	two	PS-12250	SBB-A4*, SBB-B4*, SBB-C4*, SBB-D4*
55 AH	12 volts	two	PS-12550	NFS-LBB*
* Red version available; add "R" to part number listed here				

# Appendix B Electrical Specifications

## B.1 Electrical Specifications

### AC Power

Component	Values
Main Power Supply	120 VAC, 50/60 Hz, 3.0 A; or 240 VAC, 50/60 Hz, 1.5 A
Wire size	Maximum 12 AWG (3.1 mm <sup>2</sup> ) with 600 VAC insulation

**Note:** If using an auxiliary power supply such as APS-6R, ACPS-2406, or audio amplifiers, refer to the documentation for that equipment.

### Batteries

The control panel uses only sealed lead-acid batteries for secondary standby power. Maximum battery capacity for the control panel's integral main power supply is 55 AH. Batteries larger than 25 AH require the NFS-LBB or other UL-listed battery cabinet. The table below contains specifications for batteries that can be used with the control panel; see also Appendix A.3.2 "Calculating the Battery Size":

Charger	Description	Specifications
Main Power Supply	An internal battery charger for 12 AH to 55 AH	Dual Rate: High Charge: 29.1 VDC Normal Float Charge: 27.6 VDC Charging Current: 2.0 A max (1.5 A typical)
CHG-120 Battery Charger	An external battery charger designed to charge lead-acid batteries between 25 AH and 120 AH	Dual Rate: High Charge: 28.1 VDC Normal Float Charge: 27.6 VDC Charging Current: 4.5 A
ACPS-2406 Auxiliary Charger/Power Supply	An internal battery charger for 7AH to 25 AH	Normal Float Charge: 27.6 VDC Charging Current: 1.1 A max (0.750 A typical)

## Signaling Line Circuit (SLC)

Item	Value
Voltage	24 VDC nominal, 27.6 VDC maximum
Maximum length	12,500 ft. (3810 m) per channel (NFPA Style 4) or 10,000 ft. (3048 m) total loop or circuit length (NFPA Style 6 and 7) <b>Note:</b> Refer to Appendix B.2 "Wire Requirements" for limitations.
Maximum current	400 mA peak, 200 mA average (max short circuit; circuit will shut down until short is fixed)
Maximum resistance	50 ohms (supervised and power-limited)

## Notification Appliance Circuits & Releasing Circuits

Item	Value
Max. wiring voltage drop	2 VDC (except CMX which is 1.2 VDC)
Nominal operating voltage	24 VDC
Current for all external devices connected to the control panel's power supply	6.0 A in alarm (3 A continuous)
Optional ACPS-2406	Total 6 A in alarm (5 A continuous)
Optional APS-6R	Total 6 A in alarm (4 A continuous)
Maximum signaling current/circuit per NAC	2.5 A Note: Some devices have maximum draws less than this; refer to the device's documentation.
End-of-Line Resistors (ELRs)	Control Panel NACs (TB3, TB4, TB5, TB6): 2.2K, 1/2 watt ICM-4RK, ICE-4, VCM-4RK, VCE-4, and DCM-4RK: 4.7K, 1/2 watt (2 watts on 70 Vrms audio) XP5-C, XP5-C, FCM-1 Modules: 47K, 1/2 watt

## Output Relays

Output relays for Alarm, Trouble, Supervisory, and Security are available on power supply terminals TB8, TB9, TB10, and TB11 respectively.

Contact ratings: 2.0 A @ 30 VDC (resistive)

## Four-wire Smoke Detector Power

Control Panel terminals TB7 RESET (+) and (–) supply filtered, low-noise power for four-wire smoke detectors. Specifications are:

- Nominal voltage: 24 VDC
- Maximum rated current: 1.25 A DC
- Maximum ripple voltage: 176 mVrms

Refer to the *Device Compatibility Document* for compatible 24 VDC detectors.

## Power Output

Control Panel terminals TB7 NONRST (+) and (–) supply one (1) power-limited circuit available to power external devices, such as notification appliances and annunciators.

- Nominal voltage: 24 VDC
- Maximum rated current: 1.25 A DC
- Maximum ripple voltage: 176 mVrms

Refer to the *Device Compatibility Document* for compatible devices and notification appliances.

**Note:** The Control Panel provides a total of 6.0 A of power in alarm (3 A in standby), shared by all internal circuitry and external provisions (24 V resettable and non-resettable). For power requirements, refer to the power supply calculation tables in Appendix A.

## Operating Power: AC Branch Circuit

The control panel requires connection to a separate dedicated AC branch circuit. Follow these guidelines when connecting the AC branch circuit:

- Label the branch circuit “Fire Alarm”. This must be a separate dedicated AC fire alarm circuit.
- Connect the branch circuit to the line side of the main power feed of the protected premises.
- Do not power other equipment from the fire alarm branch circuit.
- Run the AC branch circuit wire continuously, without any disconnect devices, from the power source to the fire alarm control panel.
- Overcurrent protection for the AC branch circuit must comply with Article 760 of the National Electrical Codes, as well as local codes.
- Use 12 AWG (3.1 mm<sup>2</sup>) wire with 600 VAC insulation for the AC branch circuit.

Connect the ground terminal (TB2-Earth) to a solid earth ground (a metallic, cold water pipe may be suitable in some installations). This connection is vital to maintaining the control panel's immunity to unwanted transients generated by lightning and electrostatic discharge.

## Operating Power: Secondary Power Source (Batteries)

The battery charger is current-limited and can recharge sealed lead-acid type batteries. The battery charger shuts off when the control panel is in alarm.

## B.2 Wire Requirements

Each type of circuit within the Fire Alarm Control System requires use of a specific wire type to ensure proper circuit operation. The wire gauge of a particular circuit depends on the length of that circuit and the current traveling through it. Use the table below to determine the specific wiring requirements for each circuit.

Compliance with the Federal Communications Commission (FCC) and Canadian Department of Communication regulations on electrical energy radiation requires the following: Use twisted-pair shielded wire for any non-SLC-loop wiring entering or exiting the cabinet that is not enclosed in conduit. Use twisted-pair unshielded wiring for SLC-loop wiring.

**Note:** If running an SLC in conduit with Notification Appliance Circuits, you can reduce problems by exclusively using electronic sounders (such as the MA/SS-24 Series) instead of more electronically noisy notification appliances (such as electromechanical bells or horns).

Table 16 Wire Requirements

Circuit Type	Circuit Function	Wire Requirements	Distance (feet/ meters)	Typical Wire Type
SLC (power limited)	Connects to intelligent and addressable modules.  or	Twisted-unshielded pair, 12 to 18 AWG (3.1 to 0.78 mm <sup>2</sup> ). 50 ohms maximum per length of Style 6 & 7 loops. 50 ohms per branch maximum for Style 4 loop.	12,500/3,810 8,000/2,438 4,875/1,486 3,225/983	12 AWG (3.1mm <sup>2</sup> ) 14 AWG (2.00mm <sup>2</sup> ) 16 AWG (1.30mm <sup>2</sup> ) 18 AWG (0.78mm <sup>2</sup> )
		Untwisted, unshielded wire, in conduit or outside of conduit.  <b>Note:</b> Maximum total capacitance of all SLC wiring (both between conductors and from any conductor to ground) should not exceed 0.5 microfarads.	1,000/304.8	12 to 18 AWG (3.1 to 0.78 mm <sup>2</sup> )
EIA-485 (power limited)	Connects to LCD-80, ACS modules, or TM-4 Transmitter	Twisted-shielded pair with a characteristic impedance of 120 ohms. 18 AWG (0.78 mm <sup>2</sup> ) minimum.	6,000/1829 (max)	16 AWG (1.30mm <sup>2</sup> )
EIA-232 (power limited)	Connects to Printers, CRT, or PC.	Twisted-shielded pair. 18 AWG (0.78 mm <sup>2</sup> ) minimum.	50/15.24 (without modem)	16 AWG (1.30mm <sup>2</sup> )
IDC Initiating Device Circuit	FMM-1, FMM-101XP5-M (power limited)	12-18 AWG (3.1 to 0.78 mm <sup>2</sup> ). Maximum circuit resistance is 20 ohms.		12 to 18 AWG (3.1 to 0.78 mm <sup>2</sup> )
NAC Notification Appliance Circuit	XP5-C, FCM-1 (power limited)	12-18 AWG (3.1 to 0.78 mm <sup>2</sup> ). At alarm current level, no more than a 1.2 V drop at the end of the circuit, or sized to provide the minimum rated operating voltage of the appliances used.	To meet 1.2 V drop, or sized to provide the minimum rated operating voltage of the appliances used.	12 to 18 AWG (3.1 to 0.78 mm <sup>2</sup> )
24 VDC Power Runs (power-limited)	To TM-4 Transmitter, Annunciator and FCM-1 modules	12-18 AWG (3.1 to 0.78 mm <sup>2</sup> ). Size wire so that no more than 1.2 V drop across wire run from supply source to end of any branch.	To meet 1.2 volt drop	12 to 18 AWG (3.1 to 0.78 mm <sup>2</sup> )
CHG-120	External battery charger	12 AWG (3.1 mm <sup>2</sup> ) in conduit	20/6.1 (max)	12 AWG (3.25mm <sup>2</sup> )

**Note:** Lightning arresters required on circuits extending between buildings; 999 meter length maximum to meet UL 1459.

# Appendix C Compatible Equipment

## C.1 UL-Listed Equipment

These are the most common devices at time of publishing; the most complete list of compatible intelligent SLC loop devices is provided in the *SLC Wiring Manual*; for conventional non-addressable equipment see the *Device Compatibility Document*.

### Notifier Equipment

<b>AA-30</b> 30-Watt Audio Amplifier	<b>SBB-A4</b> A-sized backbox
<b>AA-100</b> 100-Watt Audio Amplifier	<b>SBB-B4</b> B-sized backbox
<b>AA-120</b> 120-Watt Audio Amplifier	<b>SBB-C4</b> C-sized backbox
<b>ABF-1B</b> Annunciator Flush Box	<b>SBB-D4</b> D-sized backbox
<b>ABF-1DB</b> Annunciator Flush Box with Door	<b>Trim Rings</b>
<b>ABF-2B</b> Annunciator Flush Box	<b>TR-A4</b> A-sized trim ring
<b>ABF-2DB</b> Annunciator Flush Box with Door	<b>TR-B4</b> B-sized trim ring
<b>ABF-4B</b> Annunciator Flush Box	<b>TR-C4</b> C-sized trim ring
<b>ABF-4DB</b> Annunciator Flush Box with Door	<b>TR-D4</b> D-sized trim ring
<b>ABM-16AT</b> Annunciator Blank Module	<b>CCM-1</b> Communication Converter Module
<b>ABM-32A</b> Annunciator Module Blank	<b>CHS-4L</b> Chassis for voice equipment
<b>ABS-1TB</b> Annunciator Surface Box	<b>CHS-M2</b> Chassis for 1st row (included in basic equipment package)
<b>ABS-1B</b> Annunciator Surface Box	<b>CHS-4MB</b> Assembly: CHS-4N with MP-1B
<b>ABS-2B</b> Annunciator Surface Box	<b>CHS-4N</b> Chassis for 2nd, 3rd, 4th rows
<b>ABS-4B</b> Annunciator Surface Box	<b>CHG-120</b> Battery Charger
<b>ABS-8R</b> Annunciator Backbox for ACM-8R	<b>CMX-1</b> Addressable Control Module
<b>ACM-16AT</b> Annunciator Control Module	<b>CMX-2</b> Addressable Control Module
<b>ACM-24AT</b> Annunciator Control Module	<b>CPU-640</b> control panel circuit board
<b>ACM-32A</b> Annunciator Control Module	<b>CPX-551</b> Ionization Smoke Detector
<b>ACM-48A</b> Annunciator Control Module	<b>CPX-751</b> Intelligent Ionization Smoke Detector
<b>ACM-8R</b> Annunciator Control Module	<b>CRE-4</b> Control Relay Expander
<b>ACPS-2406</b> Auxiliary Charger/Power Supply	<b>CRM-4RK</b> Control Relay Module
<b>ACT-1</b> Audio Coupling Transformer	<b>CRT-2</b> Video Display Monitor with Keyboard
<b>ACT-2</b> Audio Coupling Transformer	<b>DCM-4RK</b> Dual Channel Module
<b>ADP-4B</b> Annunciator Dress Panel	<b>DP-1B</b> Blank Dress Plate
<b>AEM-16AT</b> Annunciator Expander Module	<b>DP-DISP</b> Display Dress Plate
<b>AEM-24AT</b> Annunciator Expander Module	<b>DPDW-1B</b> Double Well Dress Plate
<b>AEM-32A</b> Annunciator Expander Module	<b>DPSW-1B</b> Single Well Dress Plate
<b>AEM-48A</b> Annunciator Expander Module	<b>DPI-232</b> Direct Panel Interface
<b>AFM-16A</b> Annunciator Fixed Module	<b>FCM-1</b> NAC Module
<b>AFM-16AT</b> Annunciator Fixed Module	<b>FCPS-24</b> Field Charger Power Supply
<b>AFM-32A</b> Annunciator Fixed Module	<b>FDX-551</b> Intelligent Thermal Sensor
<b>AKS-1B</b> Annunciator Key Switch	<b>FDU-80</b> Remote Fire Annunciator
<b>APJ-1B</b> Annunciator Phone Jack	<b>FFT-7</b> Fire Fighters Telephone
<b>AMG-1</b> Audio Message Generator	<b>FFT-7S</b> Fire Fighters Telephone
<b>AMG-E</b> Audio Message Generator	<b>FHS</b> Fireman's Handset
<b>APS-6R</b> Auxiliary Power Supply	<b>FMM-1</b> Monitor Module
<b>ARM-4</b> Auxiliary Relay Module	<b>FMM-101</b> Mini Monitor Module
<b>AVL-1</b> Audio Voice Link ( <i>Not ULC-listed</i> )	<b>FSD-751P</b> Photoelectric Duct Detector
<b>BGX-101L</b> Addressable Manual Pull Station	<b>FSD-751RP</b> Photoelectric Duct Detector with alarm relay
<b>BMP-1</b> Blank Module Plate	<b>FSD-751PL</b> Low-flow Duct Detector
<b>BP-4</b> Battery Dress Plate	<b>FSD-751RPL</b> Low-flow Duct Detector with alarm relay
<b>BX-501</b> Intelligent Detectors/Sensors Base	<b>DHX-501, DHX-502</b> Duct Detectors
<b>B501</b> Intelligent base	<b>FSI-751</b> Ion Detector
<b>B501BH</b> Sounder base	<b>Acclimate Plus™ FAPT-751</b> Combination Photoelectric/Heat Detector
<b>B710LP</b> Intelligent detector base	<b>FSH-751HARSH™</b> Smoke Detector
<b>CAB-4 Series Mounting Hardware</b> (Doors and backboxes are ordered separately. Black unless "R" is added to the P/N)	<b>FSL-751 VIEW®</b> Low Profile Laser Detector
<b>Doors (Add B to the P/N for blank door)</b>	<b>FSM-101</b> Pull Station Monitor Module
<b>DR-A4</b> A-sized door, 1 row of equipment	<b>FPJ</b> Fireman's Phone Jack
<b>DR-B4</b> B-sized door, 2 rows of equipment	<b>FRM-1</b> Relay Module
<b>DR-C4</b> C-sized door, 3 rows of equipment	<b>FSP-751</b> Photo Detector
<b>DR-D4</b> D-sized door, 4 rows of equipment	<b>FSP-751T</b> Photo/Thermal Detector
<b>Backboxes (For red, add "R" to the P/N)</b>	

*continued...*

**FST-751** Thermal Detector  
**FST-751R** Thermal Detector (rate of rise)  
**FTM-1** Telephone Module  
**FZM-1** Monitor Module  
**FDM-1** Dual Monitor Module  
**ICE-4** Indicating Control Expander  
**ICM-4RK** Indicating Control Module  
**IPX-751** Advanced Multi-Sensor Intelligent Detector  
**ISO-X** Loop Fault Isolator Module  
**KDM-2** Keypad/Display Unit  
**L20-300-BX** Enclosure; recessed mount  
**L20-310-BX** Enclosure; surface mount  
**LCD-80** Liquid Crystal Display Module  
**LCD-80TM** Terminal Mode LCD Annunciator  
**LDM-32** Lamp Driver Module  
**LDM-E32** Lamp Driver Module  
**LDM-R32** Lamp Driver Module  
**LEM-320** Loop Expander Module  
**LPX-751** VIEW® Low Profile Laser Detector (CLIP mode)  
**MMX-1** Addressable Monitor Module  
**MMX-2** Addressable Monitor Module  
**MMX-101** Addressable Mini Monitor Module  
**MP-1B** Panel Module Dress Plate  
**NBG-12LRA** Agent Release-Abort Station  
**NBG-12 Series** Manual Pull Station  
**NBG-12LX** Addressable Manual Pull Station  
**NCA** Network Control Annunciator  
**NCM-F** Network Control Module (Fiber)  
**NCM-W** Network Control Module (Wire)  
**NCS** Network Control Station  
**N-ELR** Assortment ELR Pack with Mounting Plate  
**NFS-LBB** Battery Box  
**NFS-LBBR** Red Battery Box  
**P-40** Keltron Printer  
**P40-KITB** Dress plate for Keltron Printer  
**PRN-4** 80-Column Printer  
**PRN-5** 80-Column Printer  
**PRN-6** 80-Column Printer  
**PS-12120** Battery 12-volt, 12 amp-hour  
**PS-12180** Battery 12-volt, 18 amp-hour  
**PS-12250** Battery 12-volt, 25 amp-hour  
**PS-12550** Battery 12-volt, 55 amp-hour  
**PS-12600** Battery 12-volt, 60 amp-hour  
**R-120** 120 Ohm End-of-Line Resistor  
**R-2.2K** 2.2K End-of-Line Resistor  
**R-27K** 27K End-of-Line Resistor  
**R-470** 470 End-of-Line Resistor  
**R-47K** 47K End-of-Line Resistor  
**RA400** Remote Annunciator  
**RA400Z** Remote Annunciator with diode  
**RFX** Wireless Transmitter (version 2.0 and higher):  
SDRF-751 Wireless Photo/Thermal Smoke Detector;  
5817CB Wireless Monitor Module  
**RPJ-1** Fireman's Phone Jack  
**RPT-485F** EIA-485 Repeater (Fiber)  
**RPT-485W** EIA-485 Repeater (Wire)  
**RPT-485WF** EIA-485 Repeater (Wire/Fiber)  
**RM-1** Remote Microphone  
**RM-1SA** Remote Microphone  
**SCS-8, SCE-8** Smoke Control Station  
**SCS-8L, SCE-8L** Smoke Control Lamp Driver  
**SDX-551** Intelligent Photoelectric Detector  
**SDX-751** Intelligent Photoelectric Detector  
**STS-1** Security Tamper Switch  
**TM-4** Transmitter Module  
**UDACT** Universal Digital Alarm Communicator  
Transmitter  
**UZZ-256** Universal Zone Coder  
**VCE-4** Voice Control Expander  
**VCM-4RK** Voice Control Module  
**VeriFire™ Tools** Upload/Download Software  
**VP-2B** 2" Filler Dress Plate  
**XP5-C** Transponder Control Module  
**XP5-M** Transponder Monitor Module  
**XP6-8** Transponder Control Module  
**XPDP** Transponder Dress Panel  
**XPIQ** Quad Intelligent Audio Transponder  
**XPM-8** Transponder Monitor Module  
**XPM-8L** Transponder Monitor Module  
**XPP-1** Transponder Processor  
**XPR-8** Transponder Relay Module  
**XP6-C** Supervised Control Module  
**XP6-R** Six Relay Control Module  
**XP6-MA** Six Zone Interface Module  
**XP10-M** Ten Input Monitor Module

## System Sensor Equipment

**A2143-00** End of Line Resistor Assembly



## C.2 US Coast Guard & Lloyd's Register

**AA-30** Audio Amplifier  
**AA-100** Audio Amplifier  
**ABM-16AT** Annunciator Blank Module  
**ABM-32A** Annunciator Blank Module  
**ACM-16AT** Annunciator Control Module  
**ACM-24AT** Annunciator Control Module  
**ACM-32A** Annunciator Control Module  
**ACM-48A** Annunciator Control Module  
**ADP-4** Annunciator Dress Panel  
**AEM-16AT** Annunciator Expander Module  
**AEM-24AT** Annunciator Expander Module  
**AEM-32A** Annunciator Expander Module  
**AEM-48A** Annunciator Expander Module  
**AMG-1** Audio Message Generator  
**ARM-4** Auxiliary Relay Module  
**BMP-1** Blank Module Plate  
**BP-4** Battery Dress Plate  
**B224RB** Intelligent Relay Base  
**B224BI** Intelligent Isolator Base  
**B501** Intelligent Base  
**B501BH** Sounder base with B501 base  
**B501BHT B501BH** with Temporal sounder  
**B710LP** Intelligent Detector Base  
**CAB-4 Series Backboxes**  
 (Black unless "R" is added to part number)  
 SBB-A4 A size backbox  
 SBB-B4 B size backbox  
**CHS-4L** Chassis for voice system  
**CHM-M2** Chassis for 1st row (included in basic equipment package)  
**CHS-4MB** Chassis for second row  
**CRE-4** Control Relay Expander  
**CRM-4RK** Control relay Module  
**DP-1B** Blank Dress Panel  
**DP-DISP** Display Dress Panel  
**DPDW-1B** Double Well Dress Plate  
**DPSW-1B** Single Well Dress Plate  
**FCM-1** Addressable Control Module  
**FMM-1** Addressable Monitor Module  
**FMM-101** Addressable Mini Monitor Module  
**FSD-751P** Addressable Photo Duct Detector  
**FSI-751** Addressable Ion Detector  
**FSI-851** Addressable Ion Detector  
**Acclimate Plus FAPT-751** Addressable Combination Photo/Heat Detector  
**FSM-101** Addressable Pull Station Module  
**FRM-1** Addressable Relay Module  
**FSP-751** Addressable Photo Detector  
**FSP-851** Addressable Photo Detector  
**FSL-751** Addressable Laser Detector  
**FSP-751T** Addressable Photo / Thermal Detector  
**FSP-851T** Addressable Photo / Thermal Detector  
**FST-751** Addressable Heat Detector  
**FST-851** Addressable Heat Detector  
**FST-751R** Addressable Heat with Rate of Rise  
**FST-851R** Addressable Heat with Rate of Rise  
**FST-851H** Addressable High Heat  
**ICE-4** Indicating Control Expander  
**ICM-4RK** Indicating Control Module  
**ISO-X** Loop Fault Isolator Module  
**KDM-2** Keypad/Display Unit  
**LEM-320** Loop Expander Module  
**MP-1B** Panel Module Dress Plate  
**NBG-12LX** Addressable Pull Station  
**NBG-12S** Single Action Manual Pull Station  
**NBG-12** Dual Action Pull Station Hex Lock  
**NBG-12L** Dual Action Pull Station with Key Lock  
**NBG-12SP** Spanish Labeling  
**NBG-12LRA** Agent Release-Abort Station  
**NCA** Network Communication Annunciator  
**NCM-F** Network Control Module (Fiber)  
**NCM-W** Network Control Module (WIRE)  
**PS-12120** Battery 12 volt 12 Amp-Hour  
**PS-12180** Battery 12 volt 18 Amp-Hour  
**PS-12250** Battery 12 volt 25 Amp-Hour  
**PS-12550** Battery 12 volt 55 Amp-Hour

**R-120** 120 Ohm End of Line Resistor  
**R-2.2K** 2.2K Ohm End of Line Resistor  
**R-27K** 27K Ohm End of Line Resistor  
**R-470** 470 Ohm End of Line Resistor  
**R-47K** 47K Ohm End of Line Resistor  
**TM-4** Transmitter Module

### SYSTEM SENSOR HORNS/STROBES/SPEAKERS

**H24 (W)** 24VDC Horn Red (White)  
**H24K (W)** 24VDC Horn Weather proof Red Only  
**MA/SS-24D** 24VDC Electronic Sounder/Strobe  
**P2415(W)** 24VDC 15cd Horn/Strobe Red (White)  
**P241575 (W)** 24VDC 15/75cd Horn/Strobe Red (White)  
**P2430 (W)** 24VDC 330cd Horn/Strobe Red (White)  
**P24110 (W)** 24VDC 110cd Horn/Strobe Red (White)  
**P241575K** 24VDC 15/75cd Horn/Strobe Weather proof Red Only  
**P2475K** 24VDC 75cd Horn/Strobe Weather proof Red Only  
**P24110K** 24VDC 110cd Horn/Strobe Weather proof Red Only  
**P241575P(W)** 24VDC 15/75cd Horn/Strobe No Lettering Red (White)  
**P241575AG** 24VDC 15/75cd Horn/Strobe Agent Red Only  
**P241575EV** 24VDC 15/75cd Horn/Strobe Evacuation Red Only  
**S2415 (W)** 24VDC 15cd Strobe Red (White)  
**S241575 (W)** 24VDC 15/75cd Strobe Red (White)  
**S2430 (W)** 24VDC 30cd Strobe Red (White)  
**S2475 (W)** 24VDC 75cd Strobe Red (White)  
**S24110 (W)** 24VDC 110cd Strobe Red (White)  
**S241575K** 24VDC 15/75cd Strobe Weather proof Red Only  
**S2475K** 24VDC 75cd Strobe Weather proof Red Only  
**S24110K** 24VDC 110cd Strobe Weather proof Red Only  
**S241575P (W)** 24VDC 15/75cd Strobe No Lettering Red (White)  
**S241575AG** 24VDC 15/75cd Strobe Agent Red Only  
**S241575EV** 24VDC 15/75cd Strobe Evacuation Red Only  
**SP2R2415** 24VDC 15cd Speaker/Strobe Red  
**SP2W2415** 24VDC 15cd Speaker/Strobe White  
**SP2R241575** 24VDC 15/75cd Speaker Strobe Red  
**SP2W241575** 24VDC 15/75cd Speaker/Strobe White  
**SP2R2430** 24VDC 30cd Speaker/Strobe Red  
**SP2W2430** 24VDC 30cd Speaker Strobe White  
**SP2R2475** 24VDC 75cd Speaker/Strobe Red  
**SP2W2475** 24VDC 75cd Speaker/Strobe White  
**SP2R24110** 24VDC 110cd Speaker/Strobe Red  
**SP2W24110** 24VDC 110cd Speaker/Strobe White  
**SP201W** Square White Wall mount Speaker  
**SP201R** Square Red Wall mount Speaker

### MOUNTING BOXES

**WBB** Weather proof Backbox from System Sensor  
**WP-10** Weather proof Backbox from Notifier  
**BBS-SP2R** Surface mount Backbox Skirt Red  
**BBS-SP2W** Surface mount Backbox Skirt White

### SURGE SUPPRESORS

**29149** Ferrite Bead for AC input  
**3VR3** EMI Filter from CORCOM for AC input

## Notes

# Appendix D Canadian Applications

## D.1 Standalone Application

### D.1.1 NFS-640 with KDM-2

If using KDM-2 as the primary display for NFS-640, an ACS series annunciator must be mounted adjacent to the panel or within NFS-640 enclosure.

### D.1.2 NFS-640 with NCA

Network Control Annunciator (NCA) with 640-character, multi-line display complies with ULC requirements when used as the primary display for NFS-640.

## D.2 Local Network Application

To meet ULC requirements, the network's Manual Controls may only be operated from one location at any given time.

When panels networked (using NCM Network Control Modules), employ AKS-1 Key Switch on each panel's Primary Annunciator to enable its functions. NCA may be a Primary Annunciator when AKS-1B is installed. Refer to the *NCA Manual* for more information.

An NCA or Network Control Station (NCS) may be employed as a Display and Control Center. In the event that communication fails between the panels and the Control Center, the panels will continue to function in local/standalone mode.

## D.3 Automatic Alarm Signal Silence

If selecting this feature for a system requiring annunciators, consult the Authority Having Jurisdiction.

## D.4 Annunciator Applications

1. In Canada, the ACM series annunciator modules must be used to annunciate the fire alarm input points/zones only, if no multi-line sequential display is installed.
2. For Canadian applications, the following LED colors must be employed:
  - Red must be used to indicate active alarm inputs.
  - Yellow must be used to indicate supervisory, burglary or trouble signals.
  - Green must be used to indicate the presence of power or an activated output.

## D.5 Releasing Devices

Supervision for shorts is required; use REL devices and type code REL CKT ULC. (With on-board NACs, use REL-2.2K; with FCM-1 modules use REL-47K. Refer to Section 4.5 "Releasing Applications" for details.

## Notes

# Index

## Numerics

24 VDC, see DC Power 39

## A

AC, see Power 38  
 Acceptance Test 67  
 ACM-16AT 22  
 ACM-24AT 21  
 ACM-32A 22  
 ACM-48A 22  
 ACM-8R 42  
   Overview 21  
 ACPS-2406  
   Overview 17  
 ACS, see Annunciators 21  
 Addressable Modules  
   Overview 19, 20  
 AEM-16AT 22  
 AEM-24AT  
   Overview 22  
 AEM-32A 22  
 AEM-48A 22  
 AFM-16AT  
   Overview 22  
 AFM-32A  
   Overview 23  
 Agent Release-Abort Station 66  
 Alarm relays, see Form-C relays 40  
 Annunciator Fixed Modules  
   Overview 22  
 Annunciators 21  
   Overview 21  
 APS-6R 17  
   See Auxiliary Power 39  
 ARM-4  
   Installation steps 48  
   non-power-limited circuits 42  
   Overview 24  
   Stand-off and Terminal Locations 49  
 Audio Amplifiers, see Voice Alarm System 25  
 Audio Message Generator, see Voice Alarm System 25  
 Auxiliary Relay Module, see ARM-4 48

## B

B224BI 19  
 Backboxes  
   Battery boxes 17  
 Backup-alarm switches 41  
 Basic Equipment Packages 12  
 Batteries  
   Battery Boxes 17  
   Battery calculations 69, 71, 72, 73, 74  
   Battery Checks and Maintenance 68  
   Battery specifications 75  
   Installation 38  
   Overview 17  
 Blank modules 16

## C

Cabinets  
   Mounting 29  
   Overview 16  
 California code 47

Canadian Applications 83  
 central receiving unit, also see UDACT manual 60  
 Chassis 16, 36, 48  
 CHG-120  
   Overview 18  
 Circuit Board, see CPU 13  
 Compatible Equipment 79  
 Components 14, 15  
 Control Modules: Overview 20  
 Control Panel Circuit Board 13, 14, 15  
 CPU 13  
   drawing 13, 14, 15  
   Installation steps 31  
 CPU-640 (120V operation) 12  
 CPU-640E (240V operation) 12  
 CRE-4  
   non-power-limited circuits 42  
   Overview 24  
 CRM-4RK 43  
   Connections 47  
   CRM-4RK/CRE-4 48  
   non-power-limited circuits 42  
 CRTs 55  
   CRT/PRN combination 55  
   CRT-2 Configuration 52  
   CRT-2 Function Keys and parameters 54  
   CRT-2 Overview 23  
   Installation 50–55

## D

D35 on ICM-4RK 47  
 DC, see Power 38  
 Detectors  
   Detector bases 19  
   listing 18  
   Overview 18  
 Display Terminal  
   Overview 23  
 Dress Panels 16  
 Dual Channel Module  
   see also Voice Alarm System; see also Voice Alarm System Manual 25

## E

Electrical connections 37  
 Electrical Specifications 75  
 Expander boards, see Panel Circuit Modules-Expander Board Modules 43

## F

FCM-1 65  
 FCPS-24  
   Overview 18  
 Fire Fighters Telephone, see Voice Alarm System 25  
 Fire/Security Applications 59–62  
 FlashScan®  
   Overview 18  
 Form-C relays 20, 21, 24, 40, 47, 48, 76  
 Four-wire Smoke Detector  
   Specifications 76  
 FST-751 19

## I

ICM-4RK 43  
   Connections 45  
   Field-wiring 46  
   Jumpers 45  
   Overview 24  
   Resistors 47  
 Installation  
   Checklist 28  
   Preparation 27

## J

Jumper locations 14, 15  
 ICM-4RK 45

## K

KDM-2  
   Installation steps 31  
 Keltron printer 51  
   Overview 23

## L

LCD-80  
   Overview 18  
 LDM-32  
   Overview 21  
 LDM-R32  
   non-power-limited circuits 42  
   Overview 21  
 LED locations 15  
 LEM-320  
   Overview 17  
 lockout 67  
 Loop Expander Module  
   Installation steps 34

## M

Main power supply 13  
 Maintenance 67  
 microcontroller failure 41  
 Monitor Modules  
   Overview 20  
 Mounting  
   LEM 34  
   Panel Circuit Modules 44  
 Multi-Input/Output Modules 20

## N

NAC 63, 64  
 NACs  
   Backup option 41  
   NAC Connections 40  
   NAC/Releasing Circuits 64  
   Releasing circuits 40  
   Releasing functions 41  
   Specifications 76  
 NBG-12LRA 66  
 NBG-12LX 20  
 NCA 32, 33  
   also see Primary display 12  
   Overview 17  
 NCM-W/F  
   Overview 17  
 Networking 35  
 NFPA Applications

## Index

- NFPA 72 Central or Remote Station Fire Alarm System 58
- Overview 57
- Nonpower-limited circuits
  - UL wiring requirements 42
- Notification Appliance Circuits, see NACs
- O**
- Operating Power 77
- Operational Checks 67
- Output relays
  - Connections 20, 21, 24, 40, 47, 48, 76
  - Specifications 76
- P**
- Panel Circuit Modules
  - Expander Board Module 43
  - Expander Board Modules 43
  - Installation steps 35, 43
  - Overview and complete list 24
  - Ribbon cables 44
  - see also ICM-4RK, ICE-4, CRM-4RK, CRE-4, VCM-4RK, DCM-4RK, VCE-4 43
- Periodic Testing 67
- Power
  - AC Power Checklist 38
  - AC power connections 37, 38
  - AC specifications 75
  - Auxiliary Power 39
  - Battery connections 38
  - DC Power Connections 39
  - DC power connections 38
  - Installation steps 37
  - Power specifications 37, 77
- Power supply calculations 69, 71, 72, 73, 74
- Power-limited Wiring Requirements 42
- Printers 51, 55
  - Installation 50–55
  - Overview 23
  - PRN 23
- PRN/CRT combination 55
- PRN-5 50
- Proprietary Security Alarm Applications
  - Wiring 62
- Protected Premises Unit 58
- Q**
- Quad Intelligent Audio Transponder
  - Overview 20
- R**
- RA400Z 19
- Related Documentation 8
- Relays, see Form-C relays 40
- Releasing Circuit Connections 40
- Releasing Circuits
  - Connections 40
  - Releasing Applications 63–66
  - Releasing Applications, Canada 83
  - Specifications 76
- Releasing Device
  - Connections 64
  - FCM-1 Connections 65
- Remote Microphone, see Voice Alarm System 26
- Resistor locations
  - ICM-4RK 47
- S**
- S5000 modules, see Panel Circuit Modules 24
- Security relays, see Form-C relays 40
- security switch, wiring 62
- Security Tamper Switch 60
- Service 67
- Signaling Line Circuit, see SLC 18
- SLC 18, 34
  - see also SLC Wiring Manual 56
  - specifications 76
- Specifications 76
- Stacker-connector 34
- Stand-off Lengths 31
- STS-1 62
- Supervisory and Security contacts
  - configuring as Alarm contacts 40
- Supervisory relays, see Form-C relays 40
- Supplemental Documentation 8
- Switches
  - Backup-alarm 41
  - switch locations 14, 15
- System
  - Features 11
  - Limitations 12
  - Options 12
- System current draws 69, 71, 72, 73, 74
- System Description 11
- T**
- TCC-1B, see Voice Alarm System 25
- Terminal block locations 14, 15
- Testing 67
- TM-4
  - Overview 17
  - see Transmitter Module TM-4 41
- Transponders
  - Overview 20
- Trouble relays, see Form-C relays 40
- U**
- UDACT
  - Overview 17
- UL nonpower-limited wiring
  - requirements 42
- UL Requirements 42
- UZC-256
  - Overview 17
- V**
- VCC-1B, see Voice Alarm System 25
- VeriFire 54
- Voice Alarm System
  - Overview 25, 26
  - see also Voice Alarm System Manual 25
- Voice Control Module, see Voice Alarm System 25
- VTCC-1B, see Voice Alarm System 25
- W**
- Wiring
  - Proprietary Security Alarm Applications 62
  - Wire Requirements 77

## Limited Warranty

**NOTIFIER®** warrants its products to be free from defects in materials and workmanship for eighteen (18) months from the date of manufacture, under normal use and service. Products are date stamped at time of manufacture. The sole and exclusive obligation of **NOTIFIER®** is to repair or replace, at its option, free of charge for parts and labor, any part which is defective in materials or workmanship under normal use and service. For products not under **NOTIFIER®** manufacturing date-stamp control, the warranty is eighteen (18) months from date of original purchase by **NOTIFIER®**'s distributor unless the installation instructions or catalog sets forth a shorter period, in which case the shorter period shall apply. This warranty is void if the product is altered, repaired or serviced by anyone other than **NOTIFIER®** or its authorized distributors or if there is a failure to maintain the products and systems in which they operate in a proper and workable manner. In case of defect, secure a Return Material Authorization form from our customer service department. Return product, transportation prepaid, to **NOTIFIER®**, 12 Clintonville Road, Northford, Connecticut 06472-1653.

This writing constitutes the only warranty made by **NOTIFIER®** with respect to its products. **NOTIFIER®** does not represent that its products will prevent any loss by fire or otherwise, or that its products will in all cases provide the protection for which they are installed or intended. Buyer acknowledges that **NOTIFIER®** is not an insurer and assumes no risk for loss or damages or the cost of any inconvenience, transportation, damage, misuse, abuse, accident or similar incident.

**NOTIFIER®** GIVES NO WARRANTY, EXPRESSED OR IMPLIED, OF MERCHANTABILITY, FITNESS FOR ANY PARTICULAR PURPOSE, OR OTHERWISE WHICH EXTEND BEYOND THE DESCRIPTION ON THE FACE HEREOF. UNDER NO CIRCUMSTANCES SHALL **NOTIFIER®** BE LIABLE FOR ANY LOSS OF OR DAMAGE TO PROPERTY, DIRECT, INCIDENTAL OR CONSEQUENTIAL, ARISING OUT OF THE USE OF, OR INABILITY TO USE **NOTIFIER®** PRODUCTS. FURTHERMORE, **NOTIFIER®** SHALL NOT BE LIABLE FOR ANY PERSONAL INJURY OR DEATH WHICH MAY ARISE IN THE COURSE OF, OR AS A RESULT OF, PERSONAL, COMMERCIAL OR INDUSTRIAL USE OF ITS PRODUCTS.

This warranty replaces all previous warranties and is the only warranty made by **NOTIFIER®**. No increase or alteration, written or verbal, of the obligation of this warranty is authorized.

"**NOTIFIER**" is a registered trademark.

Warn-NL-10-2001.fm



World Headquarters  
12 Clintonville Road  
Northford, CT 06472-1653 USA  
203-484-7161  
fax 203-484-7118

[www.notifier.com](http://www.notifier.com)

NOTIFIER is a **Honeywell** company.

**ISO 9001**  
CERTIFIED  
ENGINEERING & MANUFACTURING  
QUALITY SYSTEMS