

# GPD 506/P5

## Technical Manual

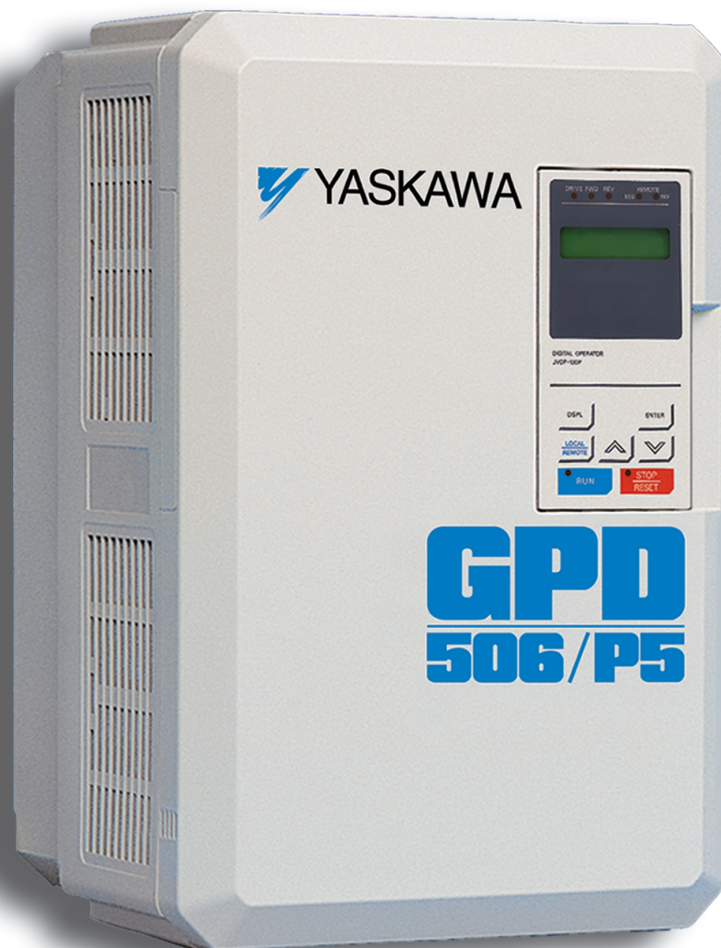

# CONTENTS

PARAGRAPH	SUBJECT	PAGE
	<b>WARNING/CAUTION STATEMENTS</b> .....	iii
	<b>GPD 506/P5 SIMPLIFIED START-UP PROCEDURE</b> .....	v
	<b>QUICK REFERENCE FOR GPD506/P5 PARAMETERS</b> .....	xi
	<b>CURRENT RATINGS &amp; HORSEPOWER RANGE</b> .....	xii
<b>1</b>	<b>INSTALLATION</b> .....	1-1
1.1	General .....	1-1
1.2	Receiving .....	1-1
1.3	Physical Installation .....	1-1
1.4	Electrical Installation .....	1-2
1.4.1	Main Circuit Input/Output .....	1-2
1.4.2	Grounding .....	1-12
1.4.3	Auxiliary Input and Output Power Option Devices .....	1-13
1.4.3a	Conformance to European EMC Directive .....	1-14
1.4.4	Control Circuit .....	1-16
	Fig. 1-3. 230V, 460V or 575V Interconnections - 2-Wire Control ...	1-19
	Fig. 1-4. 230V, 460V or 575V Interconnections - 3-Wire Control ...	1-21
<b>2</b>	<b>INITIAL START-UP ("LOCAL" CONTROL)</b> .....	2-1
2.1	Pre-power Checks .....	2-1
2.2	Test Run Using Digital Operator ("Local" Control) .....	2-2
2.3	Pre-operation Considerations .....	2-4
2.4	Storage Function .....	2-4
<b>3</b>	<b>OPERATION AT LOAD</b> .....	3-1
<b>4</b>	<b>DIGITAL OPERATOR</b> .....	4-1
4.1	General .....	4-1
4.2	Display and Keypad .....	4-1
4.2.1	Description of Quick-Start Displays .....	4-2
4.3	Basic Programming .....	4-5
4.4	Monitor Displays .....	4-6
<b>5</b>	<b>PROGRAMMABLE FEATURES</b> .....	5-1
5.1	General .....	5-1
5.2	Accel/Decel Time .....	5-3
5.3	Accel/Decel: S-Curve Characteristics .....	5-4
5.4	Auto-restart .....	5-5
5.5	Carrier Frequency .....	5-6
5.6	Critical Frequency Rejection .....	5-7
5.7	DC Injection Braking .....	5-8
5.8	Digital Operator Display Selection .....	5-9
5.9	Energy Saving Control .....	5-11
5.10	Frequency Reference Command Bias/Gain .....	5-13
5.11	Frequency Reference Input Signals (Auto/Manual) .....	5-15
5.12	Frequency Reference Upper & Lower Limits .....	5-17
5.13	Frequency Reference - Loss Detection .....	5-18
5.14	Frequency Reference Retention .....	5-19

## CONTENTS – Continued

PARAGRAPH	SUBJECT	PAGE
5.15	Jog Reference .....	5-20
5.15.1	Local/Remote Changeover .....	5-21
5.16	Modbus Control .....	5-22
5.16.1	Miscellaneous Protective Functions .....	5-25
5.17	Momentary Power Loss Ride-thru .....	5-26
5.18	Multi-function Analog Monitor Output (Term. AM & AC) .....	5-27
5.19	Multi-function Input Terminals (Term. S2 - S6) .....	5-28
	• Remote/Local .....	5-31
	• Multi-step Speed .....	5-31
	• External Base Block .....	5-33
	• Speed Search .....	5-34
	• Timer Function .....	5-36
	• Sample/Hold Command .....	5-37
	• Up/Down Function .....	5-40
5.20	Multi-function Output Terminals (Term. MA, MB, & MC; M1 & M2) .....	5-41
5.21	Overtorque /Undertorque Detection .....	5-43
5.22	PID Control .....	5-45
5.23	Reset Codes; 2-Wire, 3-Wire Initialization .....	5-50
5.23.1	Slip Compensation .....	5-51
5.24	Stall Prevention .....	5-53
5.25	Stopping Method .....	5-55
5.26	Thermal Overload Protection .....	5-57
5.27	Torque Compensation .....	5-59
5.28	V/f Pattern - Standard .....	5-60
5.29	Input Phase Loss Detection .....	5-63
<b>6</b>	<b>FAULT INDICATION AND TROUBLESHOOTING</b> .....	<b>6-1</b>
6.1	General .....	6-1
6.2	Displaying Fault Sequence .....	6-4
6.3	Troubleshooting Flowcharts .....	6-5
6.4	Diode and IGBT (Transistor) Module Resistance Test .....	6-17
<b>App. 1</b>	<b>LISTING OF PARAMETERS</b> .....	<b>A1-1</b>
<b>App. 2</b>	<b>SPECIFICATIONS</b> .....	<b>A2-1</b>
<b>App. 3</b>	<b>CAPACITY RELATED PARAMETERS</b> .....	<b>A3-1</b>
<b>App. 4</b>	<b>GPD 506/P5 SPARE PARTS</b> .....	<b>A4-1</b>
<b>App. 5</b>	<b>GPD 506/P5 DIMENSIONS</b> .....	<b>A5-1</b>
<b>App. 6</b>	<b>DYNAMIC BRAKING CONNECTIONS</b> .....	<b>A6-1</b>

# WARNINGS AND CAUTIONS

## WARNING

YASKAWA manufactures component parts that can be used in a wide variety of industrial applications. The selection and application of YASKAWA products remain the responsibility of the equipment designer or end user. YASKAWA accepts no responsibility for the way its products are incorporated into the final system design.

Under no circumstances should any YASKAWA product be incorporated into any product or design as the exclusive or sole safety control. Without exception, all controls should be designed to detect faults dynamically and fail safely under all circumstances. All products designed to incorporate a component part manufactured by YASKAWA must be supplied to the end user with appropriate warnings and instructions as to that part's safe use and operation. Any warnings provided by YASKAWA must be promptly provided to the end user.

YASKAWA offers an express warranty only as to the quality of its products in conforming to standards and specifications published in the YASKAWA manual. **NO OTHER WARRANTY, EXPRESS OR IMPLIED, IS OFFERED.** YASKAWA assumes no liability for any personal injury, property damage, losses, or claims arising from misapplication of its products.

## WARNING

- Do not connect or disconnect wiring while the power supply is turned on.
- The internal capacitor remains charged even after the power supply is turned OFF. Before servicing, disconnect all power to the drive to prevent electric shock. Status indicator LEDs and Digital Operator display will be extinguished when the DC bus voltage is below 50 VDC. Wait at least 1 minute after the power supply is disconnected, and all indicators are OFF.
- Do not perform a withstand voltage test on any part of the unit. This electronic equipment uses semiconductors and may be damaged by high voltage.
- Do not remove the digital operator or the blank cover unless the power supply is turned OFF. Never touch a printed circuit boards (PCB) while the power supply is turned ON.
- The drive is not suitable for circuits capable of delivering more than 18000 RMS symmetrical amperes, 250V maximum (200V class units) or, 18000 RMS symmetrical amperes, 480V maximum (400V class units).

## CAUTION

**Know your application before using either Initialization function of *n001* . This parameter must be set to " 0 ", " 1 ", " 2 ", or " 3 " to operate the drive. (See paragraph 5.23 for additional information.)**

**8 = Factory 2-Wire Control Initialization (Maintained RUN Contact)**

**9 = Factory 3-Wire Control Initialization (Momentary START/STOP Contact)**

**Entering either Initialization code resets all parameters, and automatically returns *n001* setting to " 1 ". If the GPD 506/P5 is connected for 3-Wire control and this constant is set to " 8 " (2-Wire Control Initialization), the motor may run in reverse direction **WITHOUT A RUN COMMAND APPLIED**. Equipment damage or personal injury may result.**

**When drive is programmed for auto-restart (*n060* = " 1 " – " 10 "), the motor may restart unexpectedly — personal injury may result.**

**Parameter *n012* must be set to proper motor voltage.**

Wiring should be performed only by qualified personnel.

Always ground the GPD 506/P5 using ground terminal ( $\perp$ ). See paragraph 1.4.3, "Grounding".

Verify that the rated voltage of the drive matches the voltage of the incoming power.

Never connect main circuit output terminals T1, T2, and T3 to AC main circuit power supply.

All parameters have been factory set. Do not change their settings unnecessarily.

Do not perform a "HIPOT" or withstand voltage test on any part of the GPD 506/P5. Equipment uses semi-conductors and is vulnerable to high voltage.

The Control PCB employs CMOS ICs which are easily damaged by static electricity. Use proper electrostatic discharge (ESD) procedures when handling the Control PCB.

Any modification of the product by the user is not the responsibility of Yaskawa, and will void the warranty.

## IMPORTANT

- Some drawings in this manual are shown with the protective covers and shields removed, in order to describe detail with more clarity. Make sure all covers and shields are replaced before operating this product.
- This manual may be modified when necessary because of product improvement, modification, or changes in specifications.
- To order a copy of this manual, if your copy has been damaged or lost, contact your YASKAWA representative or visit our webpage, [www.drives.com](http://www.drives.com).
- YASKAWA is not responsible for any modification of the product made by the user, doing so will void the warranty.

# GPD506/P5 Simplified Startup Procedure

This procedure is a simplified step by step guide to installing, programming, and using a GPD506/P5 drive. It highlights several common installation configurations.

## INSTALLATION

1. Be certain your input voltage source, motor and drive nameplates are all marked either 230V, 460V or 600V. Other voltages can be used, but require additional programming.  
**CAUTION: Verify that the input voltage matches the drive's nameplate BEFORE applying power or severe damage will result.**
2. Mount drive on a vertical surface with adequate space for air circulation (4.7" above and below, 1.2" on each side).
3. Remove front cover, fit conduit to bottom plate, and connect power and ground wires as shown.  
**CAUTION: BE CERTAIN YOU CONNECT INPUT POWER TO TERMINALS L1, L2, AND L3 ONLY, OR SERIOUS DAMAGE WILL RESULT. CONNECT MOTOR TO TERMINALS T1, T2, AND T3 ONLY.**

## POWER WIRING SCHEMATIC

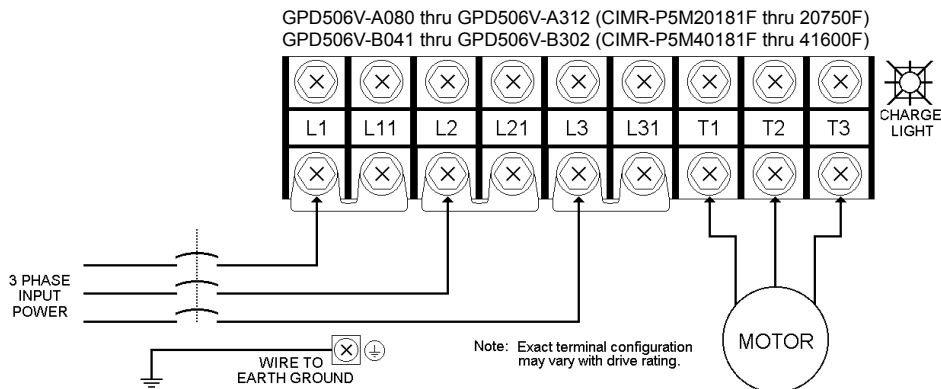
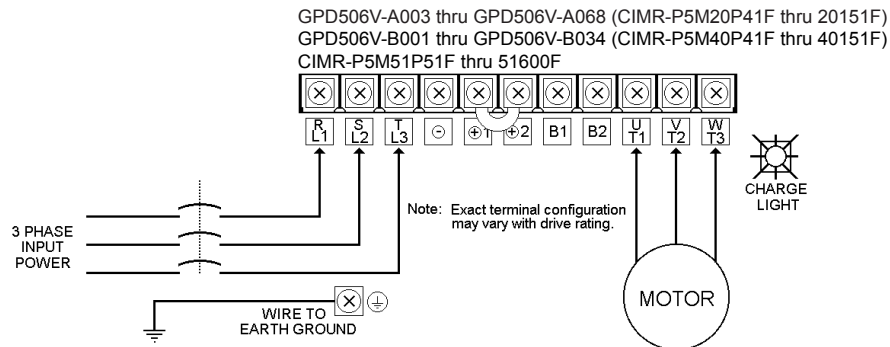

4. **Replace cover and apply input power** – digital operator shows “Frequency Ref 00.0 Hz”; DRIVE, SEQ, REF & STOP LEDs are on. Press the **LOCAL / REMOTE** button. The SEQ & REF LEDs should go off. Press and hold the **UP ARROW** button until the display shows “6.0 Hz, then press the **ENTER** button. Press the **RUN** button and note the direction of motor rotation. If rotation is incorrect, remove power, wait for charge light to go out, then switch wires between terminals T1 and T2. Replace the front cover and apply input power.

5. **Digital Operator**

To access a “Quick Start” display, press the **DSPL** button until the desired display is on the screen. Use the **UP** and **DOWN** keys to adjust the value then press the **ENTER** key.

To access a parameter, press the **DSPL** button until the word “Parameter” is on the upper left side of the screen. Use the **UP** and **DOWN** keys until the desired parameter number is on the right side of the screen, then press **ENTER**. Use the **UP** and **DOWN** keys to adjust the value then press **ENTER** then **DSPL**.

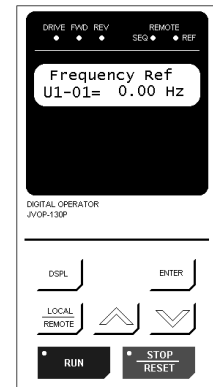

Before the drive will accept a RUN command, the DRIVE LED must be on. Press the **DISPL** key until the DRIVE LED comes on. For more specific information on the digital operator, Section 4.

6. **Control Terminal Wiring** – Remove power and wait for the charge light to go out before making control terminal connections. Control wiring should be sized 16 to 20 AWG.

Control wiring should be shielded, with the shield wire connected to terminal E(G) and the other end of the shield left open. As shown at right there are two SC terminals provided for wiring convenience.

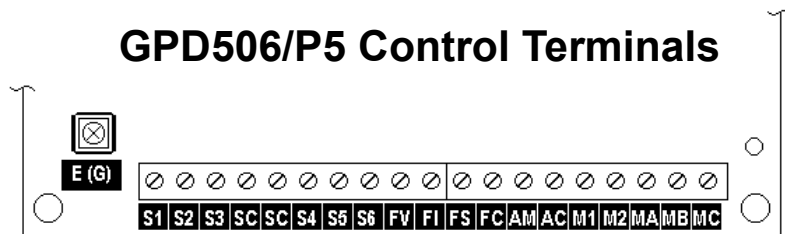

7. **Choose a configuration from Table 1 below.** Each example listed below contains a control wiring diagram, operation explanation, and all necessary programming.

**Table 1: Drive Configuration Examples**

Sequence* Source (Run / Stop)	Reference* Source (Motor Speed)	Description	Example Page
Digital Operator	Digital Operator	This method requires no control wiring connections to the drive. It is most often used during startup of the drive.	Example 1
2-wire	4-20 mA	This method is the same as Example 2 but the reference comes from a remote 4 – 20 mA source such as a PLC.	Example 2
3-wire	Speed Potentiometer	This method is similar to Example 3, but utilizes a remote mounted speed control (potentiometer).	Example 3

\* For a more detailed explanation of sequence and reference, see Definitions page.

## Example 1: Sequence & Reference From The Digital Operator

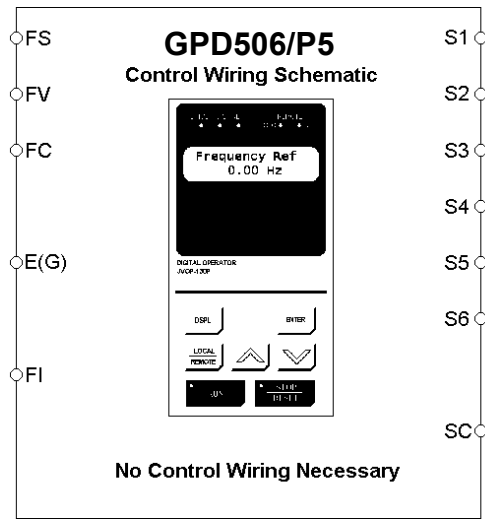

When the drive is set up with the sequence and the reference coming from the digital operator, it is in “Local” control. Local control is often used during startup to verify motor operation, rotation, etc. The drive can be temporarily placed in “Local” control simply by pressing the **LOCAL / REMOTE** key. When the drive is in “Local” control, the SEQ and REF LEDs are off. If power is removed and then restored, the drive will come up in the “Remote” mode (SEQ and REF LEDs are on).

The drive can be programmed so that even if power is lost, the drive will come up in the local mode (see Table 2 below).

### OPERATION:

- The frequency reference is programmed into the “Frequency Reference” quick start display.
- The drive can be started by pressing the **RUN** key on the digital operator.
- The drive can be stopped by pressing the **STOP** key on the digital operator.
- The direction of the motor can be changed regardless of motor speed by changing the “Forward/Reverse” quick start display.

**Table 2: Programming required for “Local” mode**

Parameter	Display	Description
n001	Password 3	Allows access to all parameters in the drive.
n002	Oper Mode Select SEQ=OPR REF=OPR	This parameter sets the drives sequence (start/stop) and reference (motor speed) to come from the digital operator (local).
Quick Start Display	Motor Rated FLA X.X A	Enter the motor’s full load amps (as shown on the motor nameplate).
Quick Start Display	Frequency Ref X.X Hz	Enter into this parameter how fast you want the motor to go.
Quick Start Display	Forward / Reverse For	With this display, the motor direction can be changed regardless of motor speed.



## Example 2: Remote Sequence (2-Wire) & Remote Reference (4 – 20 mA)

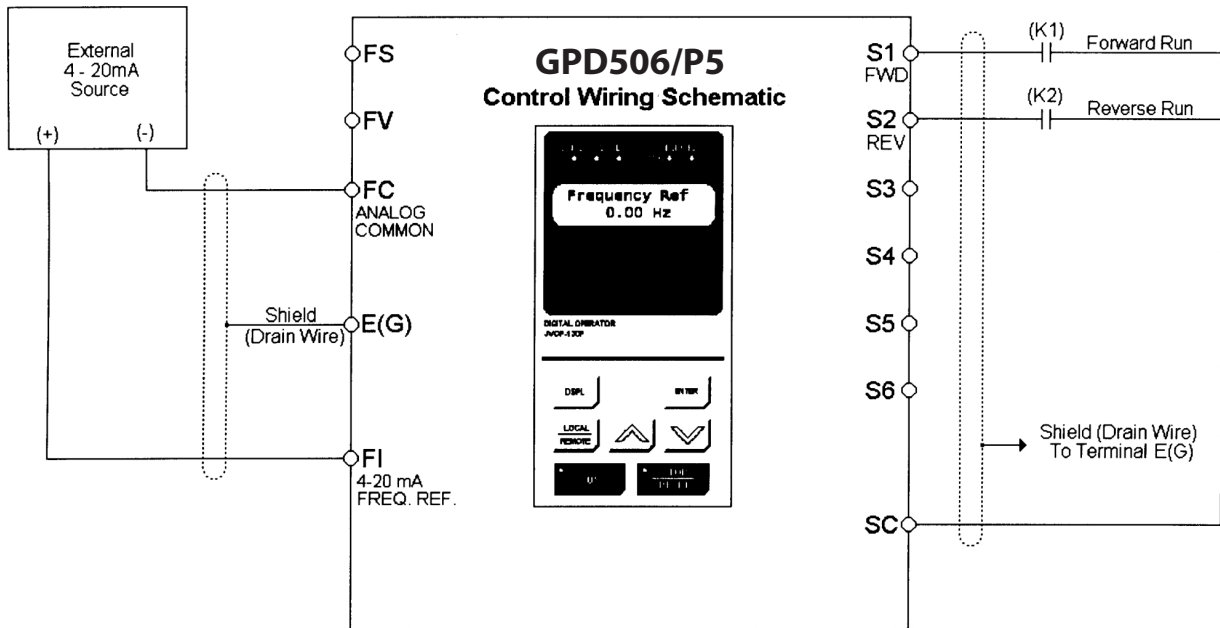

This configuration is used when the start & stop signals and the frequency reference come from a remote source, such as a PLC. It can also be used with a maintained switch when it is desirable to have the drive restart on restoration of power. It should not be used where safety of attending personnel might be threatened by a restart.

### OPERATION:

- Close (K1) to Run Forward.
- Close (K2) to Run Reverse.
- If both (K1) & (K2) are closed, the drive stops and displays the error message: “EF Ext Fault”.
- Frequency reference is proportional to the signal level at Terminal FI. 4mA = 0 Hz, 12mA = 30 Hz, & 20mA = 60 Hz.
- If the **LOCAL / REMOTE** key is pressed, the drive will behave the same as illustrated in Example 1.

**Table 3: Programming Required For Remote 2-wire Sequence & Remote (4-20 mA) Reference**

Parameter	Display	Description
n001	Password 8	The drive will perform a 2-wire reset. <b>CAUTION:</b> Setting this value will reset all parameters to their original factory settings (all previous adjustments will be lost) <i>When the drive completes the reset, this parameter returns to a value of 1.</i>
n001	Password 3	After doing the reset above, the password parameter returned to a 1. Change it to a 3 to get access to all parameters in the drive.
n043	Analog Input Sel FV=AUX FI=MSTR	This parameter sets terminal FI to be the frequency reference.
Quick Start Display	Motor Rated FLA X.X A	Enter the motor’s full load amps (as shown on the motor nameplate).

NOTE: After the above adjustments have been made, the DRIVE, SEQ, REF and STOP LEDs will be illuminated.

### Example 3: Remote Sequence (3-Wire) & Speed Potentiometer

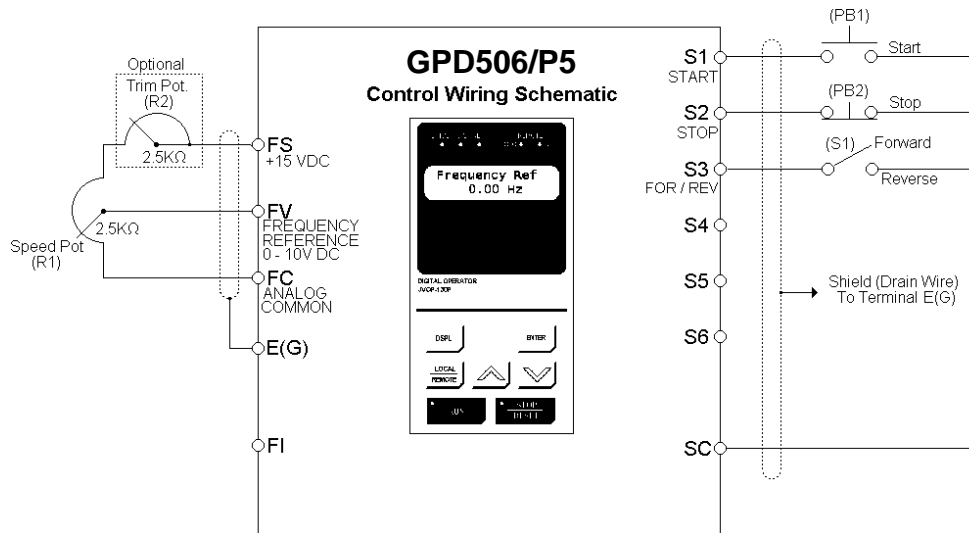

This configuration is best when a person rather than an external controller (PLC, relay, etc.) controls the drive. Both potentiometers ((R1) & (R2)) should have a resistance value between 2000Ω and 3000Ω and be rated for at least 1 Watt. The trim pot is optional, but without it the manual speed pot will output 10V (60 Hz) at just two-thirds of its rotation.

**OPERATION:**

- Close pushbutton (PB1) momentarily while pushbutton (PB2) is closed and the drive will start. Pushbutton (PB1) does *NOT* need to be maintained.
- Open pushbutton (PB2) at any time and the drive will stop.
- If switch (S1) is open the drive will run in the forward direction. If switch (S1) is closed, the drive will run in the reverse direction. Switch (S1) can be operated with the drive running at any speed.
- Frequency reference is proportional to the signal level at Terminal FV.  
0V = 0 Hz, 5V = 30 Hz, & 10V = 60 Hz.
- If the **LOCAL / REMOTE** key is pressed, the drive will behave the same as illustrated in Example 1.

**Table 4: Programming Required For Remote 3-wire Sequence & Speed Pot Reference**

Parameter	Display	Description
n001	Password 9	The drive will perform a 3-wire reset. <b>CAUTION:</b> Setting this value will reset all parameters to their original factory settings (all previous adjustments will be lost) <i>When the drive completes the reset, this parameter returns to a value of 1.</i>
n001	Password 3	After doing the reset above, the password parameter returned to a 1. Change it to a 3 to get access to all parameters in the drive.
Quick Start Display	Motor Rated FLA X.X A	Enter the motor’s full load amps (as shown on the motor nameplate).

NOTE: After the above adjustments have been made, the DRIVE, SEQ, REF and STOP LEDs will be illuminated.

After the programming is complete, the trim pot needs to be calibrated. Press **DSPL** until the “Frequency Reference” quick start display is on the screen. Verify that the SEQ and REF LEDs are illuminated. Turn the Speed Pot (R1) all the way up. Adjust the trim pot (R2) so that the “Frequency Reference” display is just flickering between 59.99 Hz and 60.00 Hz. This completes the trim pot calibration.

## Definitions

**Sequence** – refers to how the drive is started, stopped, and told which direction to run. When the sequence comes from the digital operator (local), the drive is started and stopped using the “RUN” and “STOP” keys on the digital operator, and direction is given via the “FWD/REV” key. Sequence can also come from the drive’s control terminals (remote) using either two-wire or three-wire control. **The sequence inputs to the drive do NOT require any outside voltages to activate them.** Instead, contact closures (either from switches, relay contacts or open collector circuits) activate the sequence inputs. Other sequence sources are available.

**Two-wire sequence** – utilizes a “maintained” switch or relay contact. It is used on applications where it is desirable to have the drive restart on restoration of power. It should not be used where safety of attending personnel might be threatened by a restart. This method is generally restricted to unattended fans & pumps, or where another controller is entrusted with the decision to restart. Direction is controlled by maintaining either a forward run or a reverse run command.

**Three-wire sequence** – utilizes “momentary” buttons or switches. This control scheme emulates the traditional 3-wire motor starter control. A momentary closure of a normally open run switch latches the drive in the RUN mode (STOP switch must be closed or the drive will not accept the momentary RUN command). A momentary opening of the normally closed STOP switch unlatches RUN mode bringing the drive to a stop. The three-wire sequence is used where it would be dangerous for the drive to restart after a power outage. This method requires an intentional restart, as the RUN command is unlatched immediately on loss of power. Direction is determined by another maintained contact closure (closed = reverse).

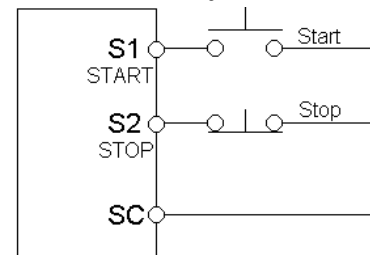

**3-Wire Sequence**

**Reference** - The frequency reference tells the drive how fast to run the motor. There are several source options for the frequency reference. First, the frequency reference can come from the digital operator (local). Simply put, the motor speed can be entered into the keypad. Second, the frequency reference can come from an analog signal (remote), such as 0 to 10 Volts DC. When 0 Volts is applied to the drive, the drive will run at zero speed. When 10V is applied to the drive, it will run at full speed. Apply anything in between and the drive will run at that corresponding frequency (2.5VDC = 25% speed = 15 Hz). Other reference sources are available.

**Local Control** – is when the sequence and/or reference comes from the digital operator. If the reference is supposed to come from the digital operator, the REF LED will be off. If the start/stop (sequence) is supposed to come from the digital operator, the SEQ LED will be off.

**Remote Control** – is when the sequence and/or reference comes from the control terminals. If the reference source is supposed to come from terminals FV or FI, the REF LED will be on. If the start/stop (sequence) is supposed to come from the terminals (2-wire or 3-wire control) the SEQ LED will be on.

## QUICK REFERENCE FOR GPD 506/P5 PARAMETERS (FACTORY SET)

PARAMETER NUMBER	FACTORY SETTING <sup>(5)</sup>	USER SETTING	PARA. REF.
n001	1		5.23
n002	SEQ = TRM REF = TRM (3)		p. A1-1
n003	230.0 (230V)		5.28 B
	or 460.0 (460V)		
	or 575.0 (575V)		
n004	Ramp to STOP (0)		5.25
n005	Rotate C.C.W. (0)		p. A1-1
n006	REV Allowed (0)		p. A1-2
n007	Enabled (1)		p. A1-2
n008	Enabled (1)		p. A1-2
n009	Enter Key Used (1)		p. A1-2
n010	1		5.28 A
n011	60.0 (Note 2)		5.28
n012	230.0 (230V)		p. A1-2
	or 460.0 (Note 2) (460V)		
	or 575.0 (575V)		
n013	60.0 (Note 2)		p. A1-2
n014	3.0 (Note 2)		p. A1-3
n015	17.2 (Note 2)		p. A1-3
n016	1.5 (Note 2)		p. A1-3
n017	11.5 (Note 2)		p. A1-3
n018	10.0		5.2
n019	10.0		5.2
n020	10		5.2
n021	10		5.2
n022	0.2 Sec (1)		5.3
n023	0		5.8
n024	0.0		5.19 B
n025	0.0		5.19 B
n026	0.0		5.19 B
n027	0.0		5.19 B
n028	0.0		5.19 B
n029	0.0		5.19 B
n030	6.0		5.15
n031	100		5.12
n032	0		5.12
n033	(Note 1) (3)		5.26

PARAMETER NUMBER	FACTORY SETTING <sup>(5)</sup>	USER SETTING	PARA. REF.
n034	STD Motor / 8 Min (1)		5.26
n035	Continue Oper (3)		p. A1-5
n036	Reverse RUN (2W) (0)		5.19
n037	Ext Fault (2)		5.19
n038	Fault Reset (4)		5.19
n039	Multi-Step Spd 1 (10)		5.19
n040	Multi-Step Spd 2 (11)		5.19
n041	Fault (0)		5.20
n042	During Running (1)		5.20
n043	FV=MSTR FI=AUX (0)		5.11
n044	4-20 mA (1)		5.11
n045	Memorize FREF (0)		5.14
n046	Not Detected (0)		5.13
n047	80		5.13
n048	100		5.10
n049	0		5.10
n050	100		5.10
n051	0		5.10
n052	Output Freq (0)		5.18
n053	1.00		5.18
n054	(Note 1)		5.5
n055	Not Provided (0)		5.17
n056	110		5.19 E
n057	(Note 1)		5.19 E
n058	(Note 1)		5.19 E
n059	(Note 1)		5.17
n060	0		5.4
n061	Activate Flt Relay (0)		5.4
n062	0.0		5.6
n063	0.0		5.6
n064	1.0		5.6
n065	Time Running Mtr (1)		p. A1-9
n066	0		p. A1-9
n067	0		p. A1-9
n068	50		5.7
n069	0.0		5.7
n070	0.0		5.7
n071	1.0		5.27
n072	Enabled (1)		5.24
n073	170 (Note 1)		5.24
n074	160 (Note 1)		5.24
n075	0.0		5.20

PARAMETER NUMBER	FACTORY SETTING <sup>(5)</sup>	USER SETTING	PARA. REF.
n076	2.0		5.20
n077	Disabled (0)		5.21
n078	160		5.21
n079	0.1		5.21
n080	0.0		5.19 F
n081	0.0		5.19 F
n082	Disabled (0)		(Note 4)
n083	7		5.29
n084	Disabled (0)		5.22 A
n085	1.00		5.22 E
n086	1.0		5.22 F
n087	10.0		5.22 F
n088	0.00		5.22 F
n089	100		5.22 G
n090	Disabled (0)		5.22 F
n091	0		5.22 F
n092	1.0		5.22 F
n093	Not Inverted (0)		p. A1-12
n094	0.0		5.22 I
n095	0.0		5.22 I
n096	Disabled (0)		5.9
n097	(Note 1)		5.9
n098	75		5.9
n099	12		5.9
n100	1		5.9
n101	Enabled (1)		5.16
n102	Coast to STOP (1)		5.16
n103	1 = 0.1Hz (0)		5.16
n104	1		5.16
n105	9600 Baud (2)		5.16
n106	No Parity (0)		5.16
n107	0.0		5.23.1
n108	30		5.23.1
n109	2.0		5.23.1
n110	Disabled (0)		5.16.1
n111	Cycle Extern RUN (0)		5.15.1
n112	6.0		
n113	50		
n114	0		
n115	(Note 1)		A3-1
n116	(Note 1)		A1-11

(Note 1) Factory setting depends on GPD 506/P5 rating. See Table A3-1.

(Note 2) Initial value is related to V/f curve selected by **n010** setting.

(Note 3) Motor rated current (**n033**) is factory set at a value related to the drive rating (see Table A3-1). User must program this parameter to the actual FLA of the motor being used. See "Thermal Overload Protection", on page 5-57.

(Note 4) Only effective when Dynamic Braking components are wired to drive terminals; see Appendix 6.

(Note 5) Factory setting shows display for both LCD and LED digital operators. If only one value is shown, it will appear on either display. If text is shown followed by a value in parentheses, the text will be displayed on the LCD digital operator, and the value in parentheses will be displayed on the LED digital operator.

### Current Ratings & Horsepower Range

RATED INPUT	CURRENT RATING (AMPS)	NOMINAL HORSEPOWER (120% OL)	NEW DRIVE MODEL NO. CIMR-P5M	OLD DRIVE MODEL NO. GPD506V-
230 V	3.2	0.75	20P41F	A003
	6	1 & 1.5	20P71F	A006
	8	2	21P51F	A008
	11	3	22P21F	A011
	17.5	5	23P71F	A017
	27	7.5 & 10	25P51F	A027
	36	15	27P51F	A036
	54	20	20111F	A054
	68	25	20151F	A068
	80	30	20181F	A080
	104	40	20221F	A104
	130	50	20300F	A130
	160	60	20370F	A160
	192	75	20450F	A192
248	100	20550F	A248	
312	125	20750F	A312	
460 V	1.8	0.75	40P41F	B001
	3.4	1 & 2	40P71F	B003
	4.8	3	41P51F	B004
	8	5	43P71F	B008
	11	7.5	44P01F	B011
	14	10	45P51F	B014
	21	15	47P51F	B021
	27	20	40111F	B027
	34	25	40151F	B034
	41	30	40181F	B041
	52	40	40221F	B052
	65	50	40301F	B065
	80	60	40371F	B080
	96	75	40451F	B096
	128	100	40551F	B128
	180	125 & 150	40750F	B180
240	200	41100F	B240	
302	250	41600F	B302	
380	300	41850F	B380	
506	350 & 400	42200F	B506	
675	500	43000F	B675	
600 V	3.5	2 & 3	51P51F	N/A
	4.1	3	52P21F	N/A
	6.3	5	53P71F	N/A
	9.8	7.5 & 10	55P51F	N/A
	12.5	10	57P51F	N/A
	17	15	50111F	N/A
	22	20	50151F	N/A
	27	25	50181F	N/A
	32	30	50221F	N/A
	41	40	50301F	N/A
	52	50	50371F	N/A
	62	60	50451F	N/A
	77	75	50551F	N/A
	99	100	50751F	N/A
130	125 & 150	50900F	N/A	
172	200	51100F	N/A	
200	200	51600F	N/A	

# Section 1. RECEIVING AND INSTALLATION

## 1.1 GENERAL

The GPD 506/P5, hereafter referred to as the drive, is a high performance sine-coded pulse width modulated special purpose AC motor drive which generates an adjustable voltage/frequency three phase output for complete speed control of most conventional squirrel cage induction motors. Automatic stall prevention and voltage boost prevents nuisance tripping during load or line side transient conditions. The drive will not induce any voltage line notching distortion back to the utility line and maintains a displacement power factor of not less than 0.98 throughout its speed range.

When properly installed, operated and maintained, the drive will provide a lifetime of service. It is mandatory that the person who operates, inspects, or maintains this equipment thoroughly read and understand this manual before proceeding.

This manual primarily describes the GPD 506/P5, but contains basic information for the operator control station as well. This manual is equally applicable to drives labeled GPD 506 or P5.

## 1.2 RECEIVING

The drive is thoroughly tested at the factory. After unpacking, verify the part numbers with the purchase order (invoice). Any damages or shortages evident when the equipment is received must be reported immediately to the commercial carrier who transported the equipment. Assistance, if required, is available from your sales representative.

If the drive will be stored after receiving, keep it in its original packaging and store according to storage temperature specifications in Appendix 2.

## 1.3 PHYSICAL INSTALLATION

Location of the drive is important to achieve proper performance and normal operating life. The unit should be installed in an area where it will be protected from:

- Direct sunlight, rain or moisture.
- Corrosive gases or liquids.
- Vibration, airborne dust or metallic particles.

When preparing to mount the drive, lift it by its base, *never* by the front cover. For effective cooling as well as proper maintenance, the drive must be installed on a flat, non-flammable vertical surface (wall or panel) using four mounting screws. There **MUST** be a **MINIMUM** 4.7 in. clearance above and below the drive to allow air flow over the heat sink fins. A minimum 1.2 in. clearance is required on each side of the drive.

A GPD 506/P5 in a free-standing floor-mount cabinet must be positioned with enough clearance for opening the door of the cabinet; this will ensure sufficient air space for cooling. Make sure air entering the drive is below 113°F (45°C) (for protected chassis drives), or below 104°F (40°C) (for NEMA 1 drives), by adding a fan or other cooling device, if needed. See environmental specifications in Appendix 2.

## 1.4 ELECTRICAL INSTALLATION

All basic interconnections (using the Digital Operator) are shown in Figures 1-3 and 1-4.

### 1.4.1 Main Circuit Input/Output

Complete wire interconnections according to Table 1-2, Figure 1-3 and Figure 1-4. Be sure to observe the following:

- Use 600V vinyl-sheathed wire or equivalent. Wire size and type should be determined by local electrical codes.
- Avoid routing power wiring near equipment sensitive to electrical noise.
- Avoid running input and output wiring in the same conduit.
- NEVER connect AC main power to output terminals T1(U), T2(V), and T3(W).
- NEVER allow wire leads to contact metal surfaces. Short-circuit may result.
- NEVER connect power factor correction capacitors to the drive output. Consult Yaskawa when connecting noise filters to the drive output.
- WIRE SIZING MUST BE SUITABLE FOR CLASS I CIRCUITS.
- When connecting motor to drive's output terminals, include a separate ground wire. Attach ground wire solidly to motor frame and to drive's ground terminal. ⚡
- When using armored or shielded cable for connection between drive and motor, solidly connect armor or shield to motor frame, and to drive's ground terminal. ⚡
- Motor lead length should NOT EXCEED 164 feet (50 meters), and motor wiring should be run in a separate conduit from the power wiring. If lead length must exceed this distance, reduce carrier frequency (see paragraph 5.8) and consult factory for proper installation procedures.
- Use UL listed closed loop connectors or CSA certified ring connectors sized for the selected wire gauge. Install connectors using the correct crimp tool recommended by the connector manufacturer.

WIRE SIZE		TERMINAL SCREW	CLOSED-LOOP CONNECTOR	CLAMPING TORQUE			
AWG	mm <sup>2</sup>			STEEL		COPPER	
				lb-in	N-m	lb-in	N-m
20	0.5	M3.5	1.25 - 3.5	7.8	0.9	7.0	0.8
18	0.75	M4	1.25 - 4	13.0	1.5	10.4	1.2
16	1.25	M4	1.25 - 4	13.0	1.5	10.4	1.2
14	2	M4	2 - 4	13.0	1.5	10.4	1.2
		M5	2 - 5	26.1	2.9	3.1	0.4
12	3.5	M4	3.5 - 4	13.0	1.5	10.4	1.2
		M5	3.5 - 5	26.1	2.9	3.1	0.4
10	5.5	M4	5.5 - 4	13.0	1.5	10.4	1.2
		M5	5.5 - 5	26.1	2.9	3.1	0.4
8	8	M5	8 - 5	26.1	2.9	3.1	0.4
		M6	8 - 6	40.9	4.6	4.8	0.5
6	14	M6	14 - 6	40.9	4.6	4.8	0.5
4	22	M8	22 - 8	100.0	11.3	11.7	1.3
2	38	M8	38 - 8	100.0	11.3	11.7	1.3
		M10	38 - 10	182.6	20.6	21.4	2.4
1/0	60	M10	60 - 10	182.6	20.6	21.4	2.4
3/0	80	M10	80 - 10	182.6	20.6	21.4	2.4
4/0	100	M10	100 - 10	182.6	20.6	21.4	2.4
		M12	100 - 12	313.0	35.4	36.7	4.2
MCM300	150	M12	150 - 12	313.0	35.4	36.7	4.2
MCM400	200	M12	200 - 12	313.0	35.4	36.7	4.2
MCM650	325	M12	325 - 12	313.0	35.4	36.7	4.2

















**Table 1-1. Typical Wire Sizing For Main Circuit\***

SECTION A. 230V					
NEW DRIVE MODEL NO. CIMR-P5M	OLD DRIVE MODEL NO. GPD506V-	TERMINAL SYMBOL	TERMINAL SCREW	WIRE SIZE	
				AWG	mm <sup>2</sup>
20P41F, 20P71F	A003, A006	L1 (R), L2 (S), L3 (T), ⊖, ⊕1, ⊕2, B1, B2, T1 (U), T2 (V), T3 (W), $\frac{\perp}{\perp}$	M4	14 - 10	2 - 5.5
21P51F	A008	L1 (R), L2 (S), L3 (T), ⊖, ⊕1, ⊕2, B1, B2, T1 (U), T2 (V), T3 (W)	M4	14 - 10	2 - 5.5
		$\frac{\perp}{\perp}$	M4	12 - 10	3.5 - 5.5
22P21F	A011	L1 (R), L2 (S), L3 (T), ⊖, ⊕1, ⊕2, B1, B2, T1 (U), T2 (V), T3 (W), $\frac{\perp}{\perp}$	M4	12 - 10	3.5 - 5.5
23P71F	A017	L1 (R), L2 (S), L3 (T), ⊖, ⊕1, ⊕2, B1, B2, T1 (U), T2 (V), T3 (W), $\frac{\perp}{\perp}$	M4	10	5.5
25P51F, 27P51F	A027, A036	L1 (R), L2 (S), L3 (T), ⊖, ⊕1, ⊕2, B1, B2, T1 (U), T2 (V), T3 (W)	M5	8	8
		$\frac{\perp}{\perp}$	M5	10 - 8	5.5 - 8
20111F	A054	L1 (R), L2 (S), L3 (T), ⊖, ⊕1, ⊕2, ⊕3, T1 (U), T2 (V), T3 (W)	M6	4	22
		$\frac{\perp}{\perp}$	M6	8	8
20151F	A068	L1 (R), L2 (S), L3 (T), ⊖, ⊕1, ⊕2, ⊕3, T1 (U), T2 (V), T3 (W)	M8	3	30
		$\frac{\perp}{\perp}$	M6	8	8
20181F	A080	L1 (R), L2 (S), L3 (T), L11, L21, L31, T1 (U), T2 (V), T3 (W)	M8	3	30
		$\frac{\perp}{\perp}$	M8	6	14
20221F	A104	L1 (R), L2 (S), L3 (T), L11, L21, L31, T1 (U), T2 (V), T3 (W)	M8	2	38
		$\frac{\perp}{\perp}$	M8	6	14
20300F	A130	L1 (R), L2 (S), L3 (T), L11, L21, L31, T1 (U), T2 (V), T3 (W)	M10	4/0	100
		$\frac{\perp}{\perp}$	M8	4	22
20370F	A160	L1 (R), L2 (S), L3 (T), L11, L21, L31, T1 (U), T2 (V), T3 (W)	M10	1/0 x 2P	60 x 2P
		$\frac{\perp}{\perp}$	M8	4	22
20450F	A192	L1 (R), L2 (S), L3 (T), L11, L21, L31, T1 (U), T2 (V), T3 (W)	M10	1/0 x 2P	60 x 2P
		$\frac{\perp}{\perp}$	M8	4	22
20550F	A248	L1 (R), L2 (S), L3 (T), L11, L21, L31, T1 (U), T2 (V), T3 (W)	M10	1/0 x 2P	60 x 2P
		$\frac{\perp}{\perp}$	M8	3	30
20750F	A312	L1 (R), L2 (S), L3 (T), L11, L21, L31, T1 (U), T2 (V), T3 (W)	M12	4/0 x 2P	100 x 2P
		$\frac{\perp}{\perp}$	M8	1	50
Section B. 460V					
NEW DRIVE MODEL NO. CIMR-P5M	OLD DRIVE MODEL NO. GPD506V-	TERMINAL SYMBOL	TERMINAL SCREW	WIRE SIZE	
				AWG	mm <sup>2</sup>
40P41F	B001	L1 (R), L2 (S), L3 (T), ⊖, ⊕1, ⊕2, B1, B2, T1 (U), T2 (V), T3 (W), $\frac{\perp}{\perp}$	M4	14 - 10	2 - 5.5
40P71F, 41P51F, 43P71F	B003, B004, B008	L1 (R), L2 (S), L3 (T), ⊖, ⊕1, ⊕2, B1, B2, T1 (U), T2 (V), T3 (W)	M4	14 - 10	2 - 5.5
		$\frac{\perp}{\perp}$	M4	12 - 10	3.5 - 5.5
44P01F	B011	L1 (R), L2 (S), L3 (T), ⊖, ⊕1, ⊕2, B1, B2, T1 (U), T2 (V), T3 (W)	M4	14 - 10	2 - 5.5
		$\frac{\perp}{\perp}$	M4	12 - 10	3.5 - 5.5

\* Consult local electrical codes for wire sizing requirements.



**Table 1-1. Typical Wire Sizing For Main Circuit - Continued\***

Section B. 460V - Continued					
NEW DRIVE MODEL NO. CIMR-P5M	OLD DRIVE MODEL NO. GPD506V-	TERMINAL SYMBOL	TERMINAL SCREW	WIRE SIZE	
				AWG	mm <sup>2</sup>
45P51F	B014	L1 (R), L2 (S), L3 (T), ⊖, ⊕1, ⊕2, B1, B2, T1 (U), T2 (V), T3 (W)	M4	12 - 10	3.5 - 5.5
			M4	12 - 10	3.5 - 5.5
47P51F	B021	L1 (R), L2 (S), L3 (T), ⊖, ⊕1, ⊕2, B1, B2, T1 (U), T2 (V), T3 (W)	M4	8 - 6	8 - 14
			M4	8 - 6	8 - 14
40111F	B027	L1 (R), L2 (S), L3 (T), ⊖, ⊕1, ⊕2, B1, B2, T1 (U), T2 (V), T3 (W)	M5	8 - 6	8 - 14
			M6	8	8
40151F	B034	L1 (R), L2 (S), L3 (T), ⊖, ⊕1, ⊕2, B1, B2, T1 (U), T2 (V), T3 (W)	M5	8 - 6	8 - 14
			M6	8	8
40181F	B041	L1 (R), L2 (S), L3 (T), L11, L21, L31, T1 (U), T2 (V), T3 (W)	M6	6	14
			M8	8	8
40221F	B052	L1 (R), L2 (S), L3 (T), L11, L21, L31, T1 (U), T2 (V), T3 (W)	M6	4	22
			M8	8	8
40301F	B065	L1 (R), L2 (S), L3 (T), L11, L21, L31, T1 (U), T2 (V), T3 (W)	M8	4	22
			M8	8	8
40371F	B080	L1 (R), L2 (S), L3 (T), L11, L21, L31, T1 (U), T2 (V), T3 (W)	M8	3	30
			M8	6	14
40451F	B096	L1 (R), L2 (S), L3 (T), L11, L21, L31, T1 (U), T2 (V), T3 (W)	M8	1	50
			M8	6	14
40551F	B128	L1 (R), L2 (S), L3 (T), L11, L21, L31, T1 (U), T2 (V), T3 (W)	M10	4/0	100
			M8	4	22
40750F	B180	L1 (R), L2 (S), L3 (T), L11, L21, L31, T1 (U), T2 (V), T3 (W)	M10	1/0 x 2P	60 x 2P
			M8	4	22
41100F	B240	L1 (R), L2 (S), L3 (T), L11, L21, L31, T1 (U), T2 (V), T3 (W)	M10	1/0 x 2P	60 x 2P
			M8	3	30
41600F	B302	L1 (R), L2 (S), L3 (T), L11, L21, L31, T1 (U), T2 (V), T3 (W)	M12	4/0 x 2P	100 x 2P
			M8	1	50
41850F	B380	L1 (R), L2 (S), L3 (T), ⊖, ⊕1, ⊕3, T1 (U), T2 (V), T3 (W)	M16	MCM650 x 2P	325 x 2P
			M8	1	50
		ℓ1 (r), ℓ2 200 (∗200), ℓ2 400 (∗400)	M4	20 - 10	0.5 - 5.5
42200F	B506	L1 (R), L2 (S), L3 (T), ⊖, ⊕1, ⊕3, T1 (U), T2 (V), T3 (W)	M16	MCM650 x 2P	325 x 2P
			M8	1/0	60
		ℓ1 (r), ℓ2 200 (∗200), ℓ2 400 (∗400)	M4	20 - 10	0.5 - 5.5
43000F	B675	L1 (R), L2 (S), L3 (T), ⊖, ⊕1, ⊕3, T1 (U), T2 (V), T3 (W)	M16	MCM650 x 2P	325 x 2P
			M8	1/0	60
		ℓ1 (r), ℓ2 200 (∗200), ℓ2 400 (∗400)	M4	20 - 10	0.5 - 5.5

\* Consult local electrical codes for wire sizing requirements.

**Table 1-1. Typical Wire Sizing For Main Circuit - Continued\***

Section C. 575V				
DRIVE MODEL NO. CIMR-P5M	TERMINAL SYMBOL	TERMINAL SCREW	WIRE SIZE	
			AWG	mm <sup>2</sup>
51P51F 52P21F	L1 (R), L2 (S), L3 (T), ⊖, ⊕1, ⊕2, B1, B2, T1 (U), T2 (V), T3 (W) ⊕	M4	14 - 10	2 - 5.5
53P71F	L1 (R), L2 (S), L3 (T), ⊖, ⊕1, ⊕2, B1, B2, T1 (U), T2 (V), T3 (W) ⊕	M4	14-10 12-10	2-5.5 3.5-5.5
55P51F	L1 (R), L2 (S), L3 (T), ⊖, ⊕1, ⊕2, B1, B2, T1 (U), T2 (V), T3 (W) ⊕	M4	12-10	3.5-5.5
57P51F	L1 (R), L2 (S), L3 (T), ⊖, ⊕1, ⊕2, B1, B2, T1 (U), T2 (V), T3 (W) ⊕	M4	10 12-10	5.5 3.5-5.5
50111F	L1 (R), L2 (S), L3 (T), ⊖, ⊕1, ⊕2, B1, B2, T1 (U), T2 (V), T3 (W) ⊕	M5	10-6 M6	5.5-14
50151F	L1 (R), L2 (S), L3 (T), ⊖, ⊕1, ⊕2, B1, B2, T1 (U), T2 (V), T3 (W) ⊕	M5 M6	8-6 10-6	8-14 5.5-14
50181F 50221F	L1 (R), L2 (S), L3 (T), ⊖, ⊕1, B1, B2, T1 (U), T2 (V), T3 (W) ⊕ ℓ1 (r), ℓ2 (s)	M6 ◆ M4	8-6 10-6 14-10	8-14 5.5-14 2-5.5
50301F	L1 (R), L2 (S), L3 (T), ⊖, ⊕1, T1 (U), T2 (V), T3 (W) ⊕ ℓ1 (r), ℓ2 (s)	M8 ◆ M4	6-1/0 8-2 14-10	14-50 8-30 2-5.5
50371F	L1 (R), L2 (S), L3 (T), ⊖, ⊕1, T1 (U), T2 (V), T3 (W) ⊕ ℓ1 (r), ℓ2 (s)	M8 ◆ M4	4-1/0 8-2 14-10	22-50 8-30 2-5.5
50451F	L1 (R), L2 (S), L3 (T), ⊖, ⊕1, T1 (U), T2 (V), T3 (W) ⊕ ℓ1 (r), ℓ2 (s)	M8 ◆ M4	3-1/0 8-2 14-10	30-50 8-30 2-5.5
50551F	L1 (R), L2 (S), L3 (T), ⊖, ⊕1, T1 (U), T2 (V), T3 (W) ⊕ ℓ1 (r), ℓ2 (s)	M8 ◆ M4	2-1/0 6-2 14-10	30-50 22-30 2-5.5
50751F	L1 (R), L2 (S), L3 (T), ⊖, ⊕1, T1 (U), T2 (V), T3 (W) ⊕ ℓ1 (r), ℓ2 (s)	M8 ◆ M4	2/0-1/0 4-2 14-10	50-60 22-30 2-5.5
50900F	L1 (R), L2 (S), L3 (T), ⊖, ⊕1, T1 (U), T2 (V), T3 (W) ⊕ ℓ1 (r), ℓ2 (s)	M10 ◆ M4	3/0-300 4-2/0 14-10	80-150 22-60 2-5.5
51100F	L1 (R), L2 (S), L3 (T), ⊖, ⊕1, T1 (U), T2 (V), T3 (W) ⊕ ℓ1 (r), ℓ2 (s)	M12 ◆ M4	300-400 4-2/0 14-10	150-200 22-60 2-5.5
51600F	L1 (R), L2 (S), L3 (T), ⊖, ⊕1, T1 (U), T2 (V), T3 (W) ⊕ ℓ1 (r), ℓ2 (s)	M12 ◆ M4	350-400 3-2/0 14-10	180-200 30-60 2-5.5

\* Consult local electrical codes for wire sizing requirements.

◆Indicates terminal uses a pressure lug.

**Table 1-2. Typical Terminal Functions and Voltages of Main Circuit**

SECTION A. 230V				
TERMINAL	FUNCTION			
	New Drive Model No. CIMR-P5	20P41F - 27P51F	20111F - 20151F	20181F - 20750F
	Old Drive Model No. GPD506V	A003-A036	A054 - A068	A080 - A312
L1 (R) L2 (S) L3 (T)	Three phase Main circuit input power supply 200 / 208 / 220V at 50 Hz; 200 / 208 / 220 / 230V at 60 Hz			
L11 L21 L31	-----		Three phase Main circuit input power supply (same as at L1, L2 & L3)	
T1 (U) T2 (V) T3 (W)	Three phase AC output to motor 0V to max. input voltage level			
B1 B2	DB Unit terminals (B1 & B2)	-----		
⊖ ⊕1 ⊕2	DC Reactor terminals (⊕1 & ⊕2) DC Bus terminals (⊕1 & ⊖)	-----		
⊕3	-----	DB Unit terminals (⊕3 & ⊖)	-----	
⊥	Ground terminal (100 ohms or less)			
SECTION B. 460V				
TERMINAL	FUNCTION			
	New Drive Model No. CIMR-P5	40P41F - 40151F	40181F - 41600F	41850F - 43000F
	Old Drive Model No. GPD506V	B001 - B034	B041 - B302	B380 - B675
L1 (R) L2 (S) L3 (T)	Three phase Main circuit input power supply 380 / 400 / 415 / 460V at 50/60 Hz			
L11 L21 L31	-----	Three phase Main circuit input power supply (same as at L1, L2 & L3)	-----	
T1 (U) T2 (V) T3 (W)	Three phase AC output to motor 0V to max. input voltage level			
B1 B2	DB Unit terminals (B1 & B2)	-----		
⊖ ⊕1 ⊕2	DC Reactor terminals (⊕1 & ⊕2) DC Bus terminals (⊕1 & ⊖)	-----		
⊕3	-----	DB Unit terminals (⊕3 & ⊖)		
ℓ1 (r) ℓ2 200 (±200) ℓ2 400 (±400)	-----	Power for heat sink fan: ℓ1 to ℓ2 200: 230 Vac ℓ1 to ℓ2 400: 460 Vac		
⊥	Ground terminal (10 ohms or less)			

----- indicates that terminals are not present.

**Table 1-2. Terminal Functions and Voltages of Main Circuit**

SECTION C. 600V			
TERMINAL	FUNCTION		
	CIMR-P5M51P51F to P5M50151F	CIMR-P5M50181F to P5M50221F	CIMR-P5M50301F to P5M51600F
L1 (R) L2 (S) L3 (T)	Three phase Main circuit input power supply 500 / 575 / 600V at 50 Hz / 60HZ		
T1 (U) T2 (V) T3 (W)	Three phase AC output to motor 0V to max. input voltage level		
B1 B2	DB Resistor terminals (B1 & B2)	-----	
⊖			
⊕1 ⊕2	DC Reactor terminals (⊕1 & ⊕2) DC Bus terminals (⊕1 & ⊖)	DB Units terminals (⊕1 & ⊖) (CIMR-P5M50301F thru 51600F) DC Bus terminals (⊕1 & ⊖)	
ℓ1 (r) ℓ2 (s)	-----	Power for heat sink fan: ℓ1 to ℓ2 : 600 VAC	
⊥	Ground terminal (100 ohms or less)		

## Main Circuit Configuration Block Diagrams 230V

CIMR-P5M20P41F to 27P51F  
GPD506V-A003 to -A036

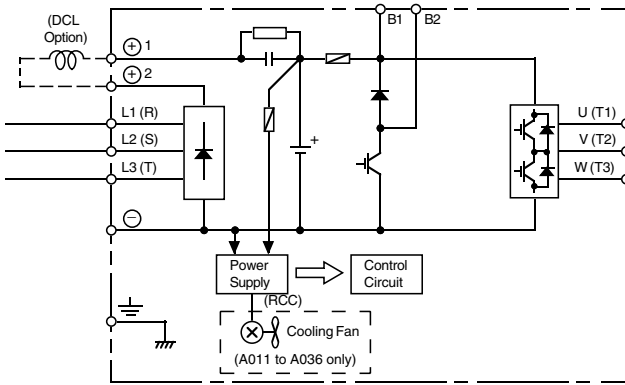

CIMR-P5M20111F to 20151F  
GPD506V-A054 to -A068

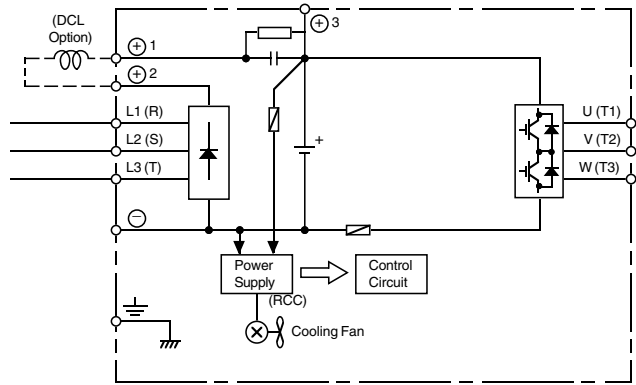

CIMR-P5M20181F to 20221F  
GPD506V-A080 to -A104

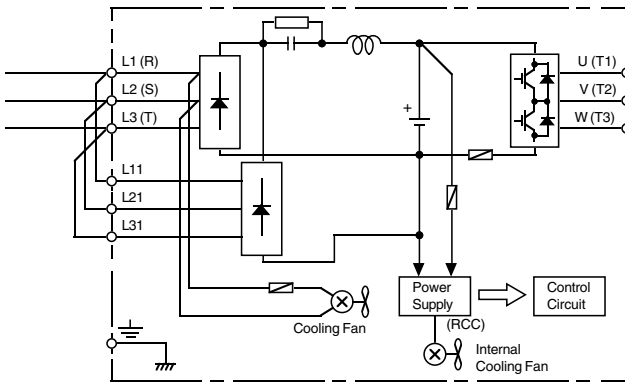

CIMR-P5M20300F to 20750F  
GPD506V-A130 to -A312

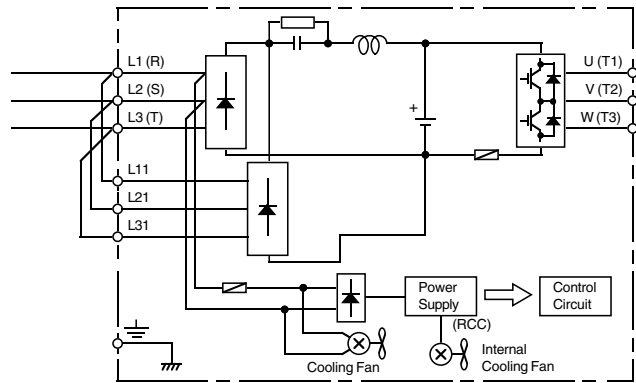

## Main Circuit Configuration Block Diagrams 460V

CIMR-P5M40P41F to 40151F  
GPD506V-B001 to -B034

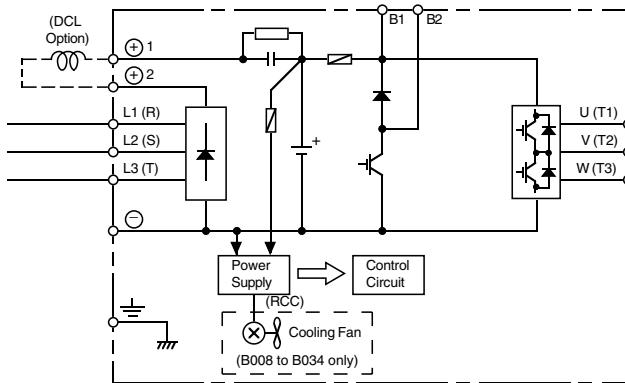

CIMR-P5M40181F to 40451F  
GPD506V-B041 to -B096

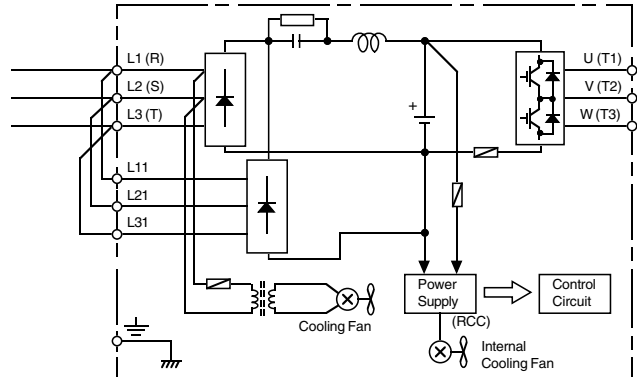

CIMR-P5M40551F to 41600F  
GPD506V-B128 to -B302

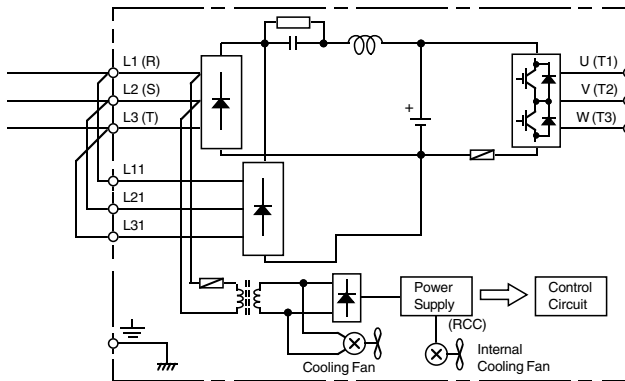

CIMR-P5M41850F to 43000F  
GPD506V-B380 to -B675

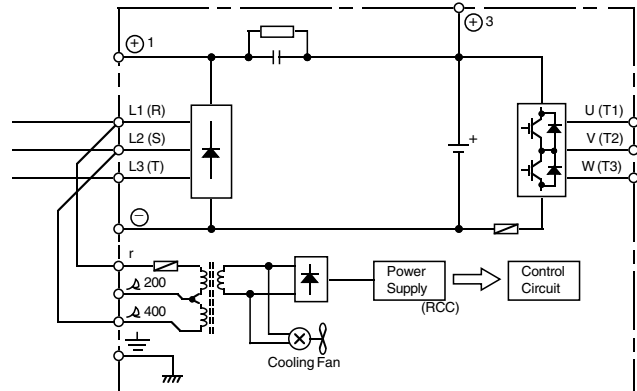

When using DC input as main circuit power, connect 460Vac to control power transformer terminals r and s400.

## Main Circuit Configuration Block Diagrams 600V

CIMR-P5M51P51F to P5M50151F

**When using DC input as main circuit power, connect 600Vac to control power transformer terminals r and s.**

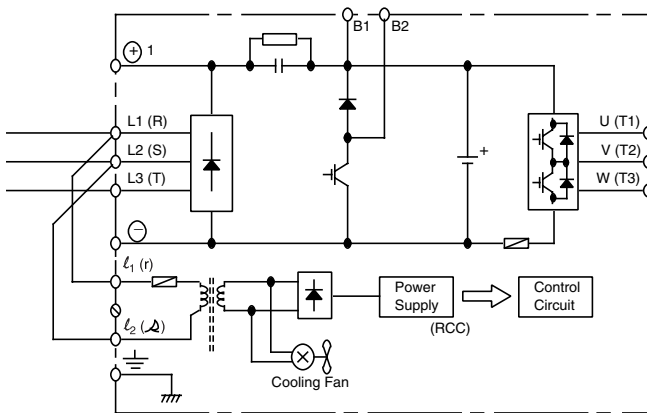
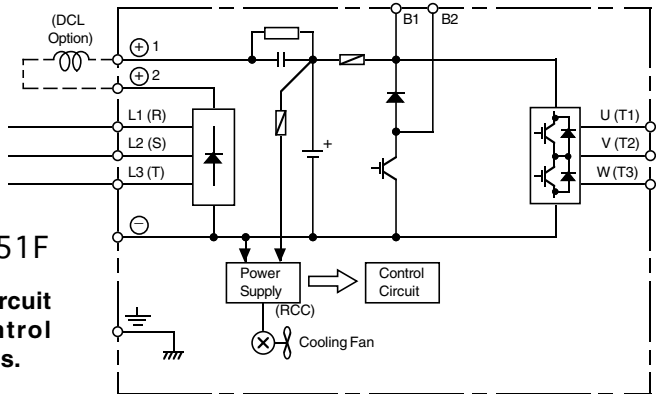

CIMR-P5M50181F to P5M50221F

**When using DC input as main circuit power, connect 600Vac to control power transformer terminals r and s.**

CIMR-P5M50301F to P5M51600F

**When using DC input as main circuit power, connect 600Vac to control power transformer terminals r and s.**

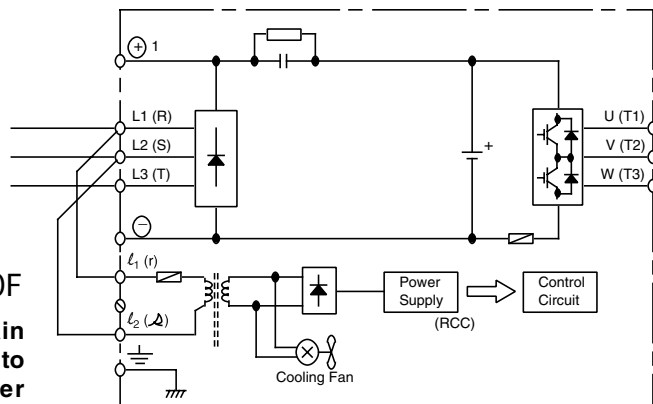

**Table 1-3. Terminal Functions and Signals of Control Circuit**

TERMINAL	FUNCTIONS		DESCRIPTION / SIGNAL LEVELS
<b>S1</b>	2-WIRE CONTROL: Forward Run / Stop signal (See NOTE 1)		Run at closed, stop at open (See NOTE 2)
	3-WIRE CONTROL: Run signal		Run at closed (See NOTE 2)
<b>S2</b>	2-WIRE CONTROL: Reverse Run / Stop signal (See NOTE 1)		Run at closed, stop at open (See NOTES 2 & 3)
	3-WIRE CONTROL: Stop signal		Stop at open (See NOTES 2 & 3)
<b>S3</b>	External fault input		Fault at closed (see NOTES 2 & 3). When the External Fault input is applied, the drive's Fault relay trips (shutdown) and the motor coasts to a stop. The Digital Operator displays " <b>EF3 Ext Fault 3</b> " failure.
<b>S4</b>	Fault Reset input (external)		Fault Reset at closed (see NOTES 2 & 3). The Fault Reset input will reset the Fault relay, if the drive is in "stopped" condition. Both Forward Run/Stop signal and Reverse Run/Stop signal must be OPEN.
<b>S5</b>	Multi-step Speed Reference 1		Effective when closed (See NOTES 2 & 3)
<b>S6</b>	Multi-step Speed Reference 2		Effective when closed (See NOTES 2 & 3)
<b>SC</b>	Sequence control input common for terminals S1-S6.		Sequence control input 0 V
<b>M1</b> <b>M2</b>	Multi-function contact output (N.O.). One of 18 functions are available, by setting of parameter <b>n042</b> .		Contact capacity: 250 Vac at 1A or below 30 Vdc at 1A or below
<b>G</b>	Connection for shield sheath of signal leads		— — — —
<b>FS</b>	Frequency reference power supply		+15V (Control power supply for frequency setting: max 20 mA)
<b>FV</b>	Frequency reference analog input (voltage); auto input – can be changed to manual by setting of parameter <b>n043</b> .		0 to +10V/100% (20K ohms) <b>See paragraph 5.11.</b>
<b>FI</b>	Frequency reference analog input (current); can be changed to voltage input by setting of parameter <b>n044</b> , and status of jumper J1.		4-20mA/100% (250 ohms) <b>See paragraph 5.11.</b>
<b>FC</b>	Frequency reference analog input common		0 V
<b>MA</b>	Multi-function contact output (N.O./N.C.). One of 18 functions are available, by setting of parameter <b>n041</b> .	Closed at fault	Contact capacity: 250 Vac at 1A or below 30 Vdc at 1A or below
<b>MB</b>		Open at fault	
<b>MC</b>		Common	
<b>AM</b>	Multi-function analog monitor (+)	Output current or output frequency is selectable	Type of analog signal (operating parameter) to be output is selected by setting of parameter <b>n052</b> . Monitor output: 0 to +11V; 2 mA maximum
<b>AC</b>	Multi-function analog monitor (-)		



NOTES:

1. When Forward Run and Reverse Run inputs are both closed for more than 500 ms, the Digital Operator displays a blinking “ **EF Ext Fault** ” alarm code and the motor (if rotating) is decelerated by the drive to a stop. This stop condition is not stored by the drive (on Digital Operator, red LED at STOP key does not light); **IF ONE OF THE INPUTS IS OPENED, THE MOTOR WILL IMMEDIATELY START UP AGAIN.**
2. Terminals S1-S6 source +24 Vdc (8mA max.) and operate in a Low = True (ON) configuration when connected to terminal SC.  
When using relays for input to terminals S1-S6, use relays with highly reliable contacts (for very small current) with a capacity of 30 Vdc or more and rated current of 100mA or higher. When using transistor (open collector) input, use transistors with rated voltage of 35 Vdc or more and rated current of 100mA or more.
3. These terminals are multi-function inputs. The indicated functions are their settings, based on a 2-Wire reset. For 3-Wire reset definitions, and other settings, see descriptions for “Multi-Function Input Terminals”, parameters *n036* thru *n040*, in paragraph 5.19.

**1.4.2 Grounding**

- The drive must be solidly grounded using the main circuit ground terminal. ≡
- If Drive is installed in a cabinet with other equipment, ground leads for all equipment should be connected to a common low-impedance ground point within the cabinet.
- The supply neutral should be connected to the ground point within the cabinet.
- Select appropriate ground wire size from Table 1-1.
- Make all ground wires as short as practical.
- NEVER ground the drive in common with welding machines or other high power electrical equipment.
- Where several drives are used, ground each directly to the ground point (see Figure 1-1). DO NOT FORM A LOOP WITH THE GROUND LEADS.
- When connecting a motor to the drive’s output terminals, include a separate ground wire. Attach ground wire solidly to motor frame and to drive’s ground terminal. ≡
- When using armored or shielded cable for connection between drive and motor, solidly connect armor or shield to motor frame, and to the drive’s ground terminal. ≡

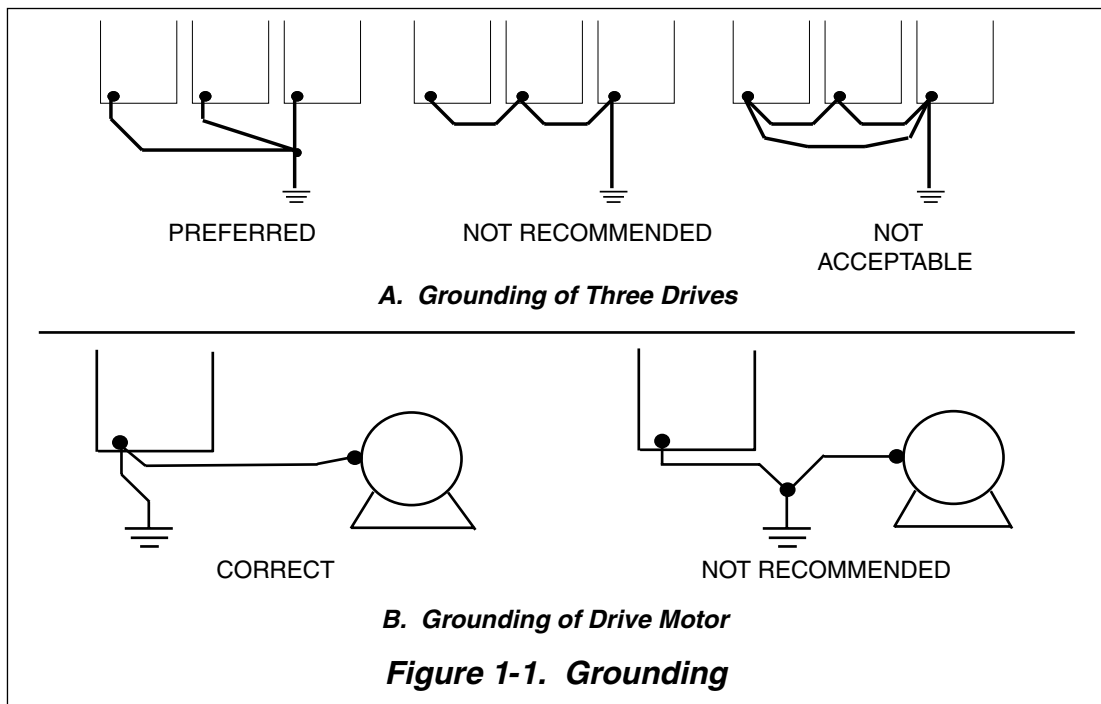

### 1.4.3 Auxiliary Input and Output Power Option Devices

A disconnect device (circuit breaker, contactor, disconnect switch, etc.) should NOT be used as a means of starting and stopping the drive or motor.

A disconnect device can be installed for emergency stop purposes, but when that disconnect device is opened, there may be loss of electrical braking.

Figure 1-2 is a factory guideline for proper wiring practices and relative locations within the electrical path from the line to the load. It does not imply what devices are needed for a particular application, nor does it show what devices were shipped with a particular order. Therefore, disregard those items in the diagram which are not being used in your installation. However, it *is* recommended that an input or DC reactor be used with models GPD506V-A003 thru -A064 (CIMR-P5M20P41F thru 20151F), -B001 thru -B034 (40P41F thru 40151F) and CIMR-P5M51P51F thru 50451F when wired to a source of 600 kVA or greater. Mount all optional power devices close to the drive, and keep electrical connections as short as possible.

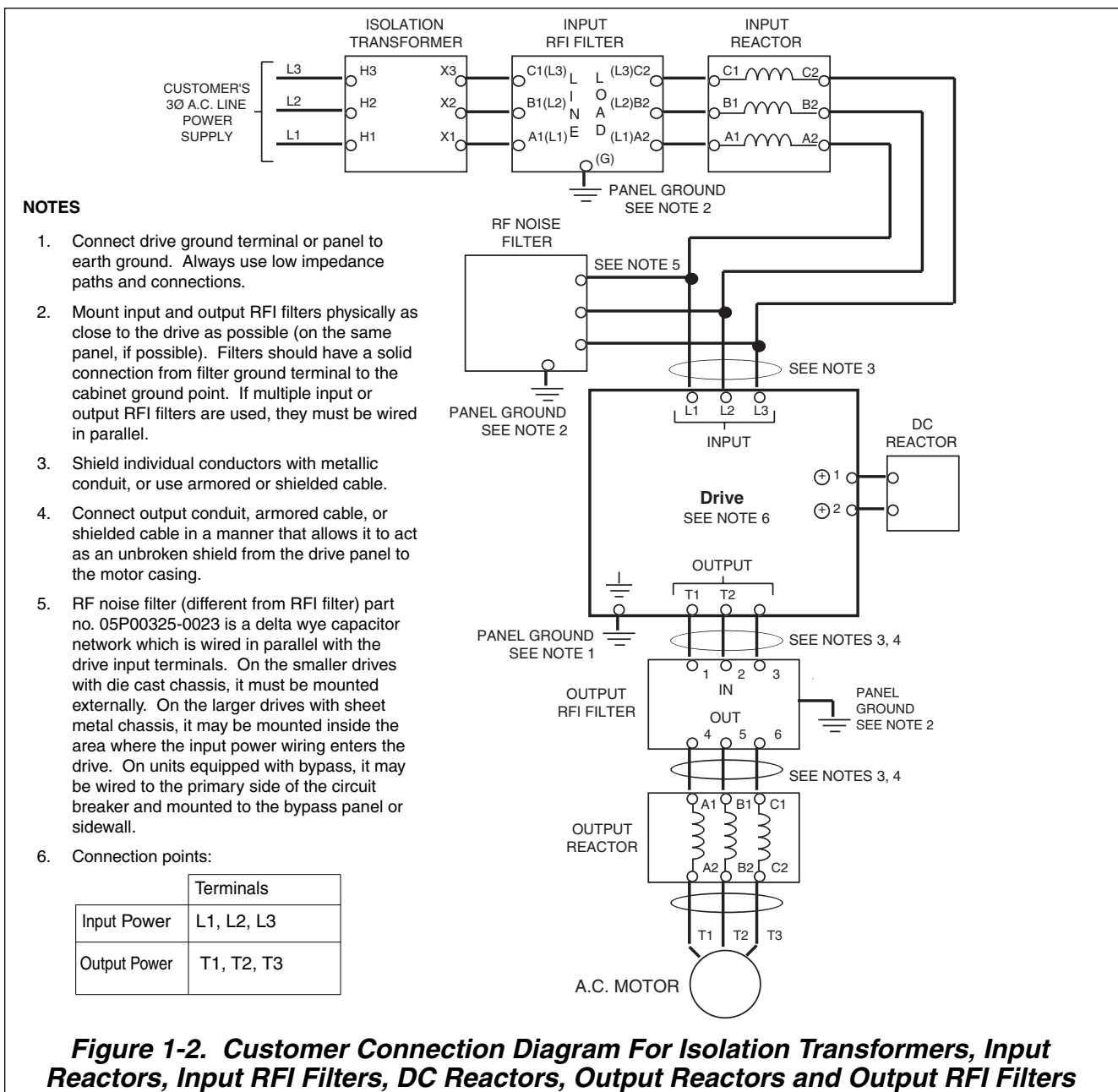

### 1.4.3a Conformance to European EMC Directive

In order to conform to EMC standards, the exclusive-use methods are required for line filter application, cable shielding and drive installation. The following explains the outline of the methods.

The line filter and drive must be mounted on the same metal plate. The filter should be mounted as close to the drive as practical. Keep cable as short as possible. The metal plate should be securely grounded. The ground of line filter and drive must be bonded to the metal plate with as much area as possible.

For mains input cables, screened cable is recommended at least within the panel. The screen of the cable should be connected to solid ground. For motor cable, screened cable (max. 20 m) must be used and the screen of the motor cable should be connected to ground at both ends by a short connection, using as large an area as practical.

For more detailed explanation, refer to Yaskawa document EZZ006543, "Installation Guidelines For EMC Directive using Yaskawa AC Drive Products."

Table 1-4 and Figure 1-2A show the line filter list for EMC standards and the installation/wiring of drive and line filter.

**Table 1-4. Line Filters for GPD 506/P5**

New Drive Model Number CIMR-P5M	Old Drive Model Number GPD506V-	Line Filter			
		Part Number 05P00325-	Rated Current (A)	Mass (kg)	Dimensions in mm <sup>(1)</sup> L x W x D <sup>(2)</sup>
40P41F	B001	0106	8	1.8	320 x 143 x 46
40P71F	B003				
41P51F	B004				
43P71F	B008	0103	20	1.8	320 x 143 x 46
44P01F	B011				
45P51F	B014				
47P51F	B021	0104	30	3.0	350 x 213 x 51
40111F	B027	0105	60	5.3	435 x 268 x 56
40151F	B034				
40181F	B041				
40221F	B052	0107	80	7.5	350 x 180 x 90
40301F	B065	0108	100	13.8	420 x 200 x 130
40371F	B080	0109	150	13.8	480 x 200 x 160
40451F	B096	0110	160	25	480 x 200 x 160
40551F	B128	0111	180	25	480 x 200 x 160
40750F	B180	0112	300	25	480 x 200 x 160
41100F	B240				
41600F	B302				
41850F	B380	0113	400	45	588 x 250 x 200
41850F	B380	0119	500	Consult Factory	
42200F	B506	0120	600		
43000F	B675	0121	900		

(1) 1mm = 0.0394 inches

(2) D is the distance the filter will extend outward from the surface of the metal plate.

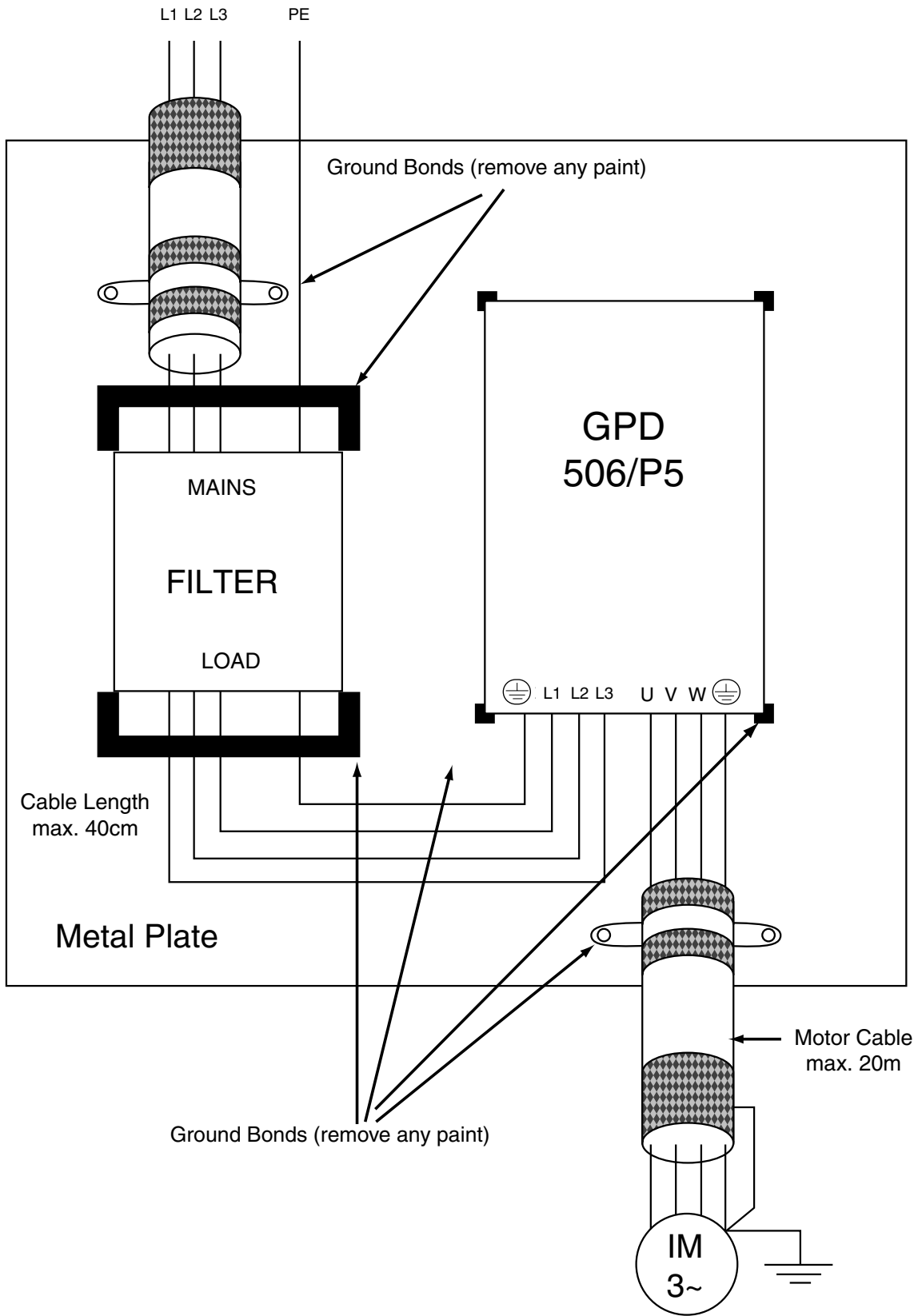

**Figure 1-2A. Installation of Line Filter and GPD 506/P5 Drive**

#### 1.4.4 Control Circuit

All basic control circuit (signal) interconnections are shown in the appropriate diagram:

- Interconnections for external two-wire control in combination with the Digital Operator are shown in Figure 1-3.
- Interconnections for external three-wire control in combination with the Digital Operator are shown in Figure 1-4.

Make wire connections according to Figures 1-3, 1-4 and Table 1-3; observe the following:

- Signal Leads: Terminals 1-8 & 11; 12-17 & 33; and 21-27.
- Control Leads: Terminals 9 & 10 and 18-20.
- Use twisted shielded or twisted-pair shielded wire (20-16 AWG [0.5 – 1.25mm<sup>2</sup>]) for control and signal circuit leads. The shield sheath **MUST** be connected at the drive end **ONLY** (terminal 12). The other end should be dressed neatly and left unconnected (floating). See Figure 1-2B.
- Signal leads and feedback leads (PG) must be separated from control leads main circuit leads and any other power cables to prevent erroneous operation caused by electrical noise.
- Lead length should **NOT EXCEED** 164 feet (50 meters). Wire sizes should be determined considering the voltage drop.
- All AC relays, contactors and solenoids should have RC surge suppressors installed across their coils.
- All DC relays, contactors and solenoids should have diodes installed across their coils.

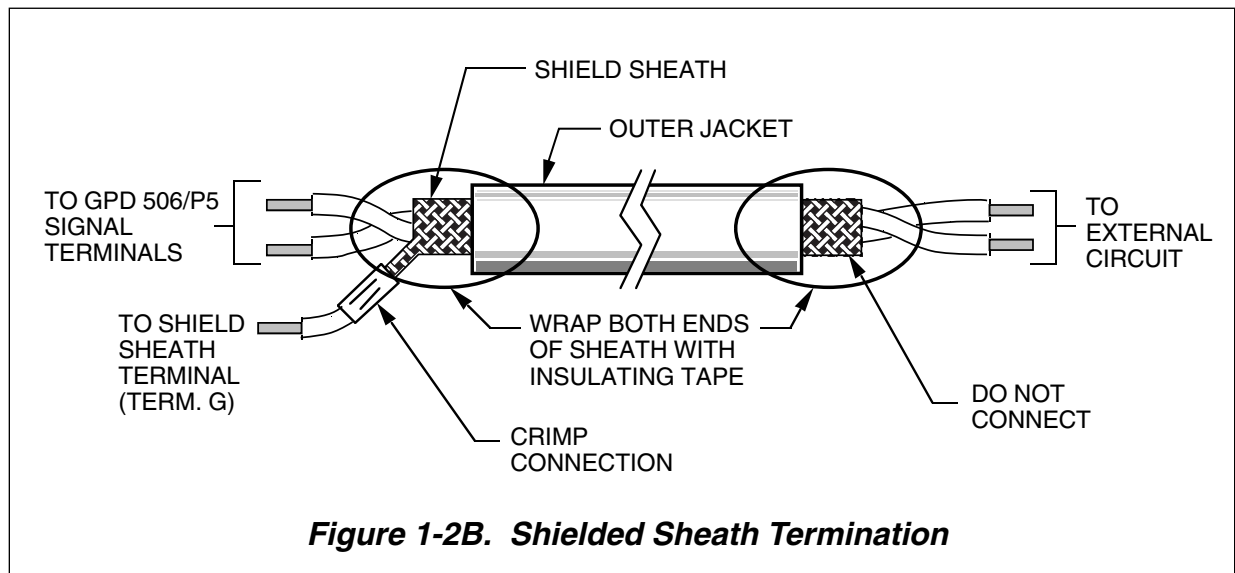



---

NOTES FOR FIGURE 1-3
----------------------

---

\* - Indicates components not supplied.

\*\* - Branch circuit protection (Circuit breaker or input fuses) must be supplied by customer.

⊙ - Indicates customer connection terminal. Wire only to terminals shown. Note that not all terminals shown are available in all ratings – see pages 1-3 thru 1-5.

( ) - Indicates alternate terminal marking, i.e., (R) and L1.

▲ - Function labels shown for these terminals are determined by factory settings of **n036** through **n040** (see paragraph 5.19).

● - Function labels shown for these terminals are determined by factory settings of **n041** & **n042** (see paragraph 5.20).

◆ - Function label shown for this terminal is determined by factory setting of **n043** & **n044** (see paragraph 5.11).

■ - Function labels shown for these terminals are determined by factory setting of **n052** (see paragraph 5.18).

1. Multiple combinations of frequency references are possible – see paragraph 5.11.
2. The Drive Electronic Thermal Overload function (**n033**, **n034**) meets standards set by UL and CSA for motor thermal overload protection. If local code requires separate mechanical overload protection, an overload relay should be installed, interlocked with the drive as shown. It should be the manual reset type to prevent automatic restart following a motor fault and subsequent contact reclosure after cool down.
3. Insulated twisted shielded wire is required.  
2-conductor #18 GA. (Belden #8760 or equivalent).  
3-conductor #18 GA. (Belden #8770 or equivalent).  
Connect shield ONLY AT drive END. Stub and isolate other end.
4. The Digital Operator is standard on every drive. Remote operators, as shown, may not be required.
5. Customer to connect terminal  $\perp$  to earth ground (100Ω or less, 230V; 10Ω or less, 460V and 600V).
6. An optional DC reactor may be added for harmonic attenuation, if needed; see separate instruction sheet for wiring.
7. If application does not allow reverse operation, **n006**, Reverse Run Prohibit Selection, should be set to "REV prohibited" ("1"), and the Reverse Run/Stop input can be eliminated.
8. These terminals are not present on all drive ratings – refer to Table 1-1.

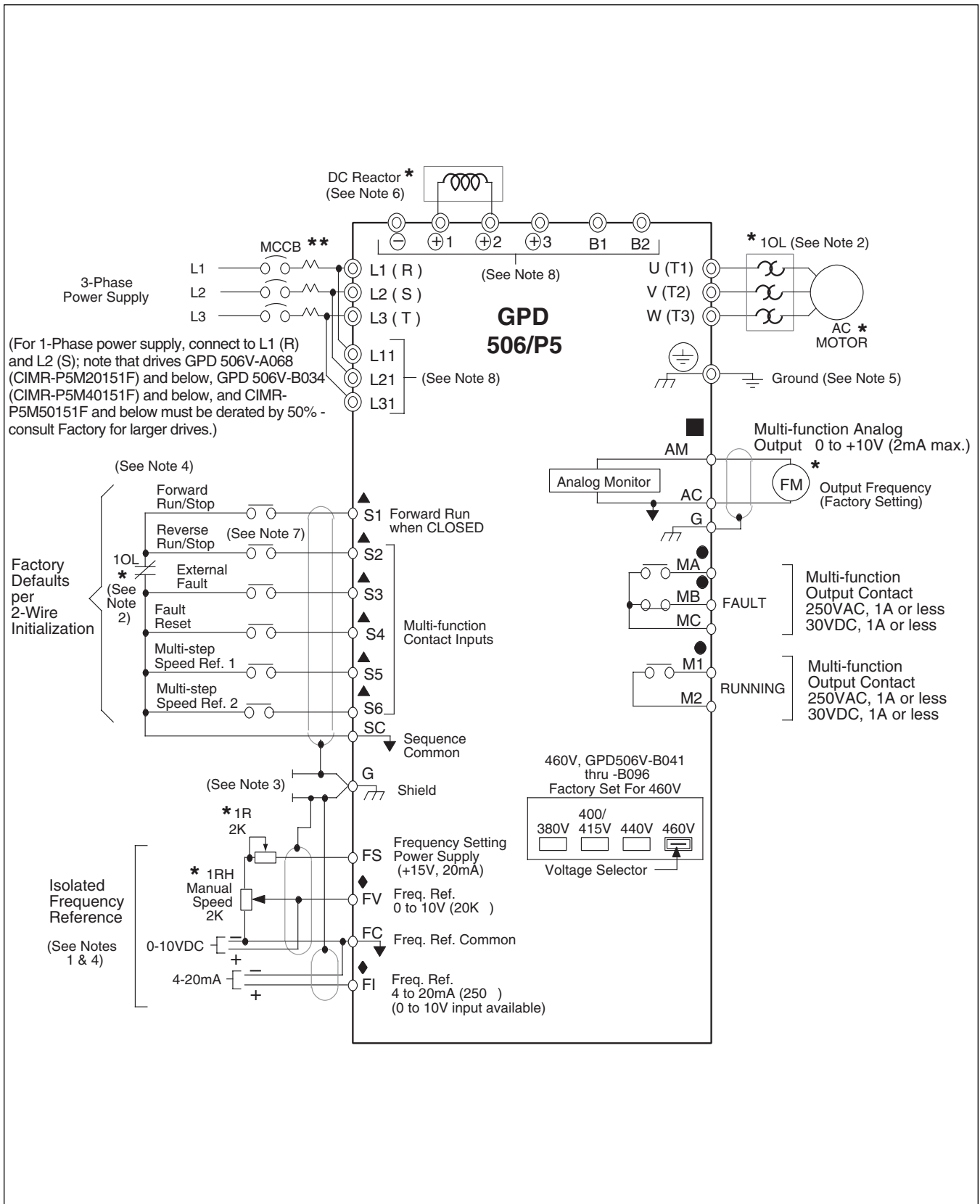

**Figure 1-3. 230V, 460V, or 600V Interconnections - 2-Wire Control (n001 = 8)  
(with parameters n036 = 0, n037 = 2,  
n038 = 4, n039 = 10, and n040 = 11)**



---

<b>NOTES FOR FIGURE 1-4</b>
-----------------------------

---

\* - Indicates components not supplied.

\*\* - Branch circuit protection (circuit breaker or input fuses) must be supplied by customer.

⊙ - Indicates customer connection terminal. Wire only to terminals shown. Note that not all terminals shown are available in all ratings – see pages 1-3 thru 1-5.

( ) - Indicates alternate terminal marking, i.e., (R) and L1.

▲ - Function labels shown for these terminals are determined by 3-Wire control factory settings of **n036** through **n040** (see paragraph 5.19).

● - Function labels shown for these terminals are determined by factory settings of **n041** & **n042** (see paragraph 5.20).

◆ - Function label shown for this terminal is determined by factory setting of **n043** & **n044** (see paragraph 5.11).

■ - Function labels shown for these terminals are determined by factory setting of **n052** (see paragraph 5.18).

1. Multiple combinations of frequency references are possible – see paragraph 5.11.
2. The Drive Electronic Thermal Overload function (**n033**, **n034**) meets standards set by UL and CSA for motor thermal overload protection. If local code requires separate mechanical overload protection, an overload relay should be installed, interlocked with the drive as shown. It should be the manual reset type to prevent automatic restart following a motor fault and subsequent contact reclosure after cool down.
3. Insulated twisted shielded wire is required.
  - 2-conductor #18 GA. (Belden #8760 or equivalent).
  - 3-conductor #18 GA. (Belden #8770 or equivalent).Connect shield ONLY AT DRIVE END. Stub and isolate other end.
4. The Digital Operator is standard on every drive. Remote operators, as shown, may not be required.
5. Customer to connect terminal  $\perp$  to earth ground (100Ω or less, 230V; 10Ω or less, 460V and 600V).
6. An optional DC reactor may be added for harmonic attenuation, if needed; see separate instruction sheet for wiring.
7. If application does not allow reverse operation, **n006**, Reverse Run Prohibit Selection, should be set to “REV prohibited” (“1”), and the Forward/Reverse input can be eliminated.
8. These terminals are not present on all drive ratings – refer to Table 1-1.

 **CAUTION**

**Before running, *n001* must be set to " 0 ", " 1 ", " 2 ", or " 3 ". Resetting drive constant *n001* to " 8 " may cause the motor to run in the reverse direction WITHOUT A RUN COMMAND, and possibly result in damage to the equipment or personal injury.**

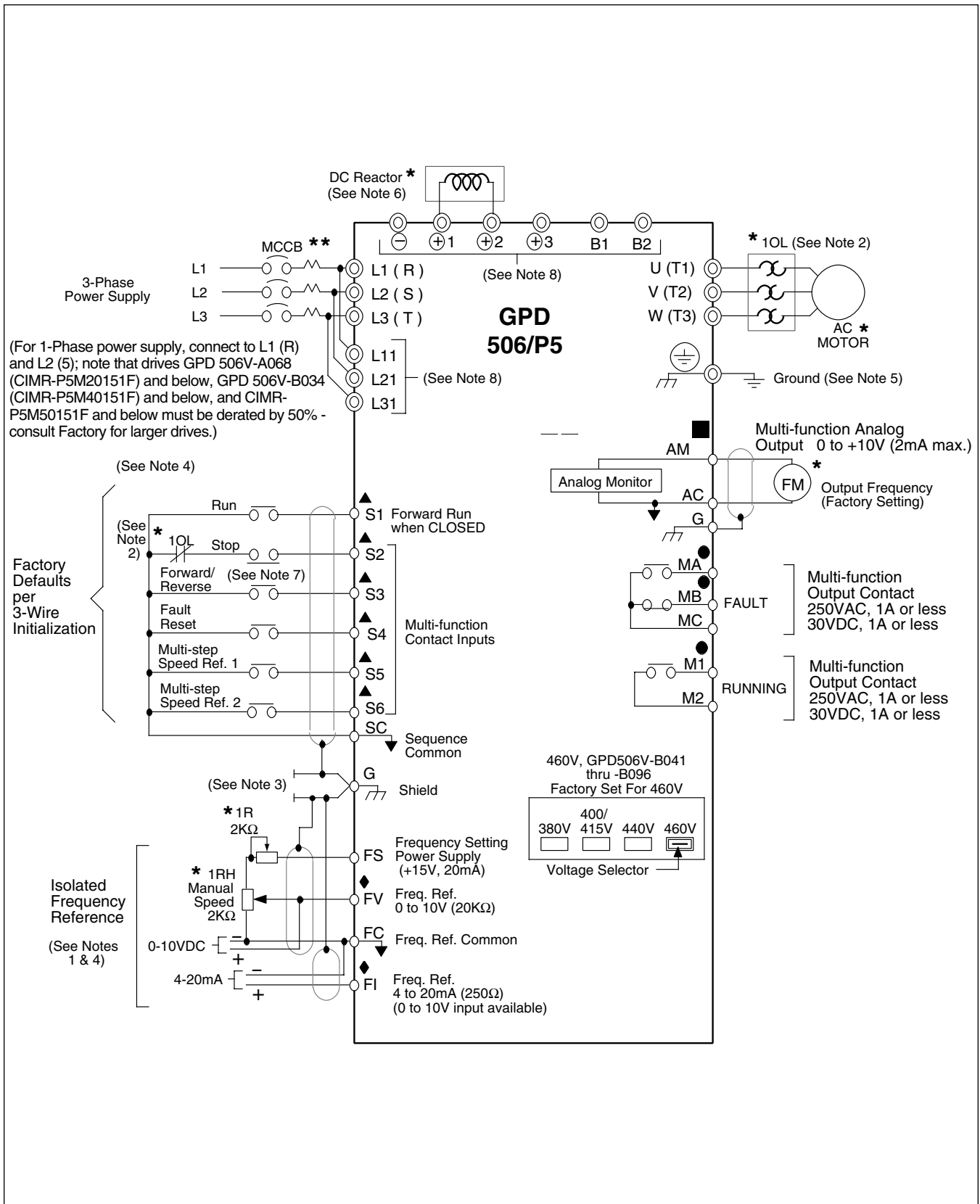

**Figure 1-4. 230V, 460V, or 600V Interconnections - 3-Wire Control (n001 = 9)  
(with parameters n036 = 1, n037 = --, n038 = 4,  
n039 = 10, and n040 = 11 )**



## Section 2. INITIAL START-UP ("LOCAL" CONTROL)

### 2.1 PRE-POWER CHECKS

- Verify wires are properly connected and no erroneous grounds exist.
- Remove all debris from the drive enclosure. Check for loose wire clippings.
- Verify all mechanical connections inside the drive are tight.
- Verify motor is not connected to load.
- Apply input power only after the front cover is in place. DO NOT remove the front cover or Digital Operator while input power is on.
- **For 460V, GPD506V-B041 thru -B096 (CIMR-P5M40181F thru 40451F):** Verify that the drive power voltage select connector, located at lower left corner inside drive chassis (see Figure 2-1), is positioned correctly for the input power line voltage. Voltage is preset to 460V at the factory. Reposition, if required, to match nominal line voltage.

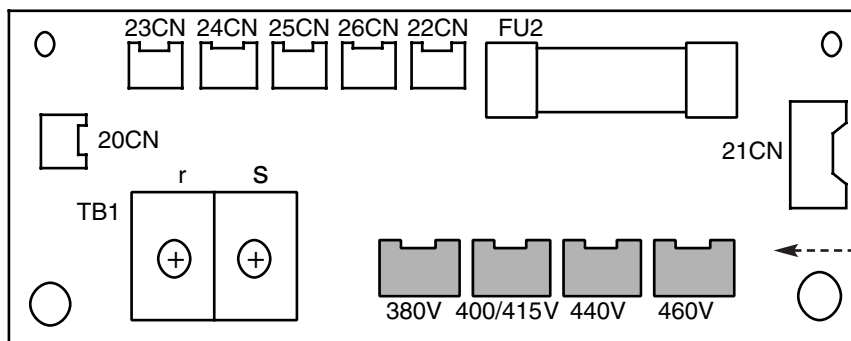

Figure 2-1a. Power Voltage Selection in 460V drive

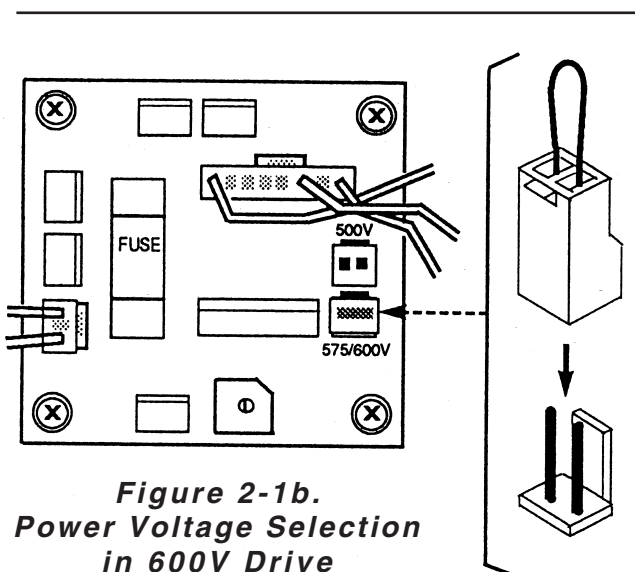
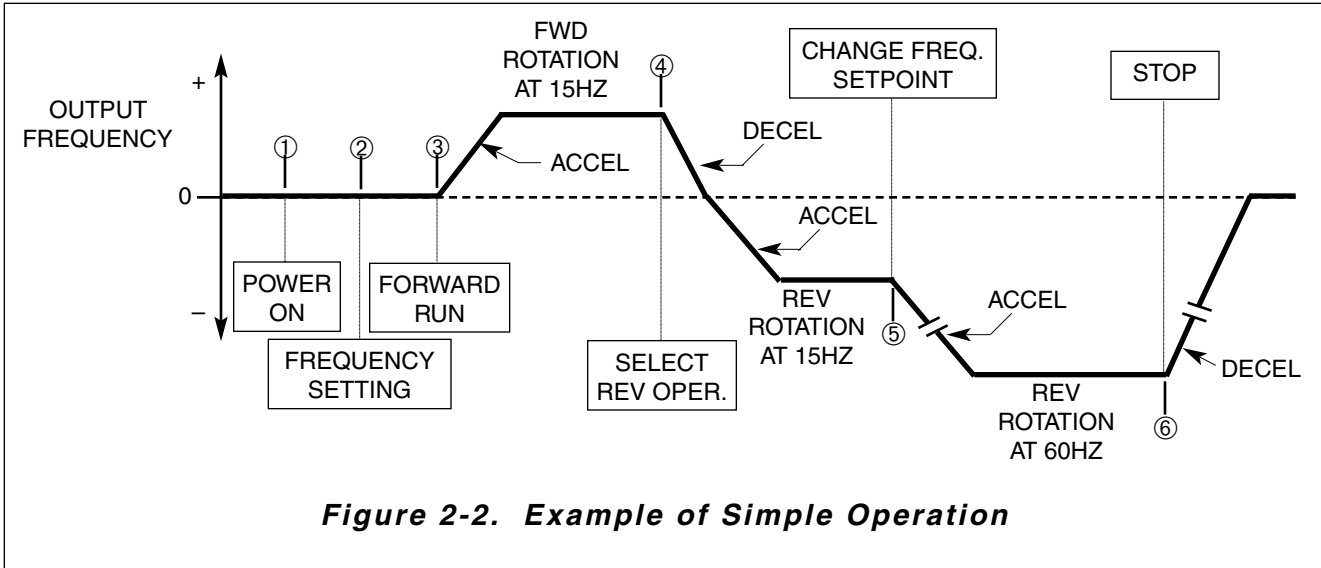

Figure 2-1b.  
Power Voltage Selection  
in 600V Drive





**For 600V CIMR-P5M50181F thru 51600F.** Verify that the drive power voltage select connector, located at lower left corner inside drive chassis (see Figure 2-1b), is positioned correctly for the input power line voltage. Voltage is preset to 575/600V at the factory. Reposition, if required, to match nominal line voltage.

## 2.2 TEST RUN USING DIGITAL OPERATOR ("LOCAL" CONTROL)







The operation described in Table 2-1 and shown in Figure 2-2 is for a standard 60 Hz motor.



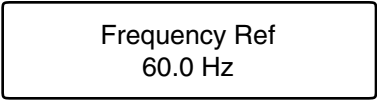

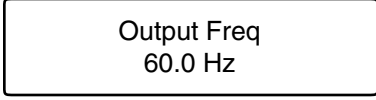

**Table 2-1. Test Run With Digital Operator**

DESCRIPTION	KEY SEQUENCE	DIGITAL OPERATOR DISPLAY
① Power ON <ul style="list-style-type: none"> <li>Displays frequency reference setting.</li> </ul>		<b>SEQ &amp; REF LEDs "ON",</b> <div style="border: 1px solid black; padding: 5px; text-align: center;">Frequency Ref 0.0 Hz</div> Drive LED "ON"
Operation Condition Setting <ul style="list-style-type: none"> <li>Select LOCAL mode.</li> </ul>	Press 	<b>SEQ &amp; REF LEDs "OFF"</b> <div style="border: 1px solid black; padding: 5px; text-align: center;">Frequency Ref 0.0 Hz</div> Drive LED "ON"
② Frequency Setting <ul style="list-style-type: none"> <li>Change reference value.</li> </ul>	Change value by pressing either  	<div style="border: 1px solid black; padding: 5px; text-align: center;">Frequency Ref 15.0 Hz</div>
<ul style="list-style-type: none"> <li>Write-in set value.</li> </ul>	Press 	<div style="border: 1px solid black; padding: 5px; text-align: center;">Frequency Ref 15.0 Hz</div>
<ul style="list-style-type: none"> <li>Select output frequency monitor display.</li> </ul>	Press 	<div style="border: 1px solid black; padding: 5px; text-align: center;">Output Freq 0.0 Hz</div>

**Table 2-1. Test Run With Digital Operator - Continued**

DESCRIPTION	KEY SEQUENCE	DIGITAL OPERATOR DISPLAY
③ Forward Run <ul style="list-style-type: none"> <li>Forward run (15 Hz)</li> </ul>	Press 	<b>RUN</b> LED turns "ON" <div style="border: 1px solid black; padding: 5px; margin: 10px auto; width: fit-content;">                         Output Freq 15.0 Hz                     </div> (after motor reaches set frequency)
④ Reverse Run <ul style="list-style-type: none"> <li>Select reverse run.</li> </ul>	Press  3 times	<div style="border: 1px solid black; padding: 5px; margin: 10px auto; width: fit-content;">                         Forward/Reverse F o r                     </div>
	Switch to "rev" by pressing either 	<div style="border: 1px solid black; padding: 5px; margin: 10px auto; width: fit-content;">                         Forward/Reverse r E v                     </div>
<ul style="list-style-type: none"> <li>Write-in set value.</li> </ul>	Press 	<div style="border: 1px solid black; padding: 5px; margin: 10px auto; width: fit-content;">                         Forward/Reverse r E v                     </div>
<ul style="list-style-type: none"> <li>Select output frequency monitor display.</li> </ul>	Press  13 times	<div style="border: 1px solid black; padding: 5px; margin: 10px auto; width: fit-content;">                         Output Freq 15.0 Hz                     </div>
⑤ Frequency Reference Value Change (15 Hz to 60 Hz) <ul style="list-style-type: none"> <li>Select frequency reference value display</li> </ul>	Press  15 times	<div style="border: 1px solid black; padding: 5px; margin: 10px auto; width: fit-content;">                         Frequency Ref 15.0 Hz                     </div>
<ul style="list-style-type: none"> <li>Change set value.</li> </ul>	Change value by pressing either 	<div style="border: 1px solid black; padding: 5px; margin: 10px auto; width: fit-content;">                         Frequency Ref 60.0 Hz                     </div>

**Table 2-1. Test Run With Digital Operator - Continued**

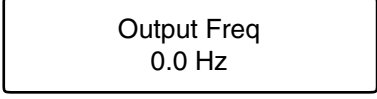
DESCRIPTION	KEY SEQUENCE	DIGITAL OPERATOR DISPLAY
⑤ (Continued) <ul style="list-style-type: none"> <li>• Write-in set value</li> </ul>	Press 	
<ul style="list-style-type: none"> <li>• Select output frequency monitor display.</li> </ul>	Press 	
⑥ Stop <ul style="list-style-type: none"> <li>• Decelerates to a stop.</li> </ul>	Press 	<p><b>RUN</b> LED blinks while motor is being decelerated and <b>STOP/RESET</b> LED turns "ON"; then <b>RUN</b> LED</p>  <p>turns "OFF"</p>

### 2.3 PRE-OPERATION CONSIDERATIONS

- After completing the start-up, connect the motor to the load.
- Additional control circuit wiring can be added, and parameters in the drive can be programmed to configure the drive system to your specific application, including "Remote" (2-wire or 3-wire) Control. (See Table 5-1 for listing of Programmable Features descriptions.)

### 2.4 STORAGE FUNCTION

The drive uses internal NV-RAM to store information when power is removed or in the event of a power failure. Therefore, when power is reapplied, operation will begin at the same state as when power was removed.

The following information is stored:

1. Last frequency command setting from Digital Operator.
2. The sequence of failure conditions that occurred before power was removed.

## Section 3. OPERATION AT LOAD

After completing the start-up, and programming of constants, turn off the AC main circuit power. Make additional wiring connections required for the external control functions selected by the constant programming. Connect the driven machine to the motor. Verify that the driven machine is in running condition, and that no dangerous conditions exist around the drive system.

### OPERATING PRECAUTIONS

- Before applying a RUN command to the drive, verify that the motor is stopped. If the application requires the capability of restarting a coasting motor, parameter **n070** must be set to give DC Braking Time at Start.
- The motor cooling effect is reduced during low-speed running. The torque needs to be reduced in accordance with the frequency. For the reduction ratio, refer to the motor catalog or technical sheet.
- **NEVER** use a motor whose full-load amps exceeds the drive rating.
- When two or more motors are operated by one drive, verify that the total motor current **DOES NOT EXCEED** the drive rating.
- When starting and stopping the motor, use the operation signals (RUN/STOP, FWD/REV), NOT the magnetic contactor on the power supply side.

Run the motor under load with control by the Digital Operator using the same procedure as for the Test Run (Table 2-1). If the Digital Operator is used in combination with external commands or external commands only are used, the procedure must be altered accordingly.

For preset starting (one-touch operation after setting the frequency), perform the following:

1. Set the frequency and press **RUN**. Motor accelerates, at the rate corresponding to the preset accel time, to the preset frequency. The accel time is set too short relative to the load if the RPM of the accelerating motor does not increase smoothly (stall prevention during acceleration is functioning) or if a fault indication is displayed on the Digital Operator.
2. Press **STOP**. Motor decelerates, at the rate corresponding to the preset decel time, to a stop. The decel time is set too short relative to the load if the RPM of the decelerating motor does not decrease smoothly (stall prevention during deceleration is functioning) or if a fault indication is displayed on the Digital Operator.



## Section 4. DIGITAL OPERATOR

### 4.1 GENERAL

All functions of the GPD 506/P5 are accessed using the Digital Operator. In addition to controlling motor operation, the operator can enter information into the drive memory to configure the drive to the application, either by using the Quick-Start Displays or by entering the Program mode.

### 4.2 DISPLAY AND KEYPAD

The Digital Operator has a 2-line by 16 character LED display. Both numeric and alphanumeric data can appear on the display.

Indicator lamps and keys on the Digital Operator are described in Figure 4-1.

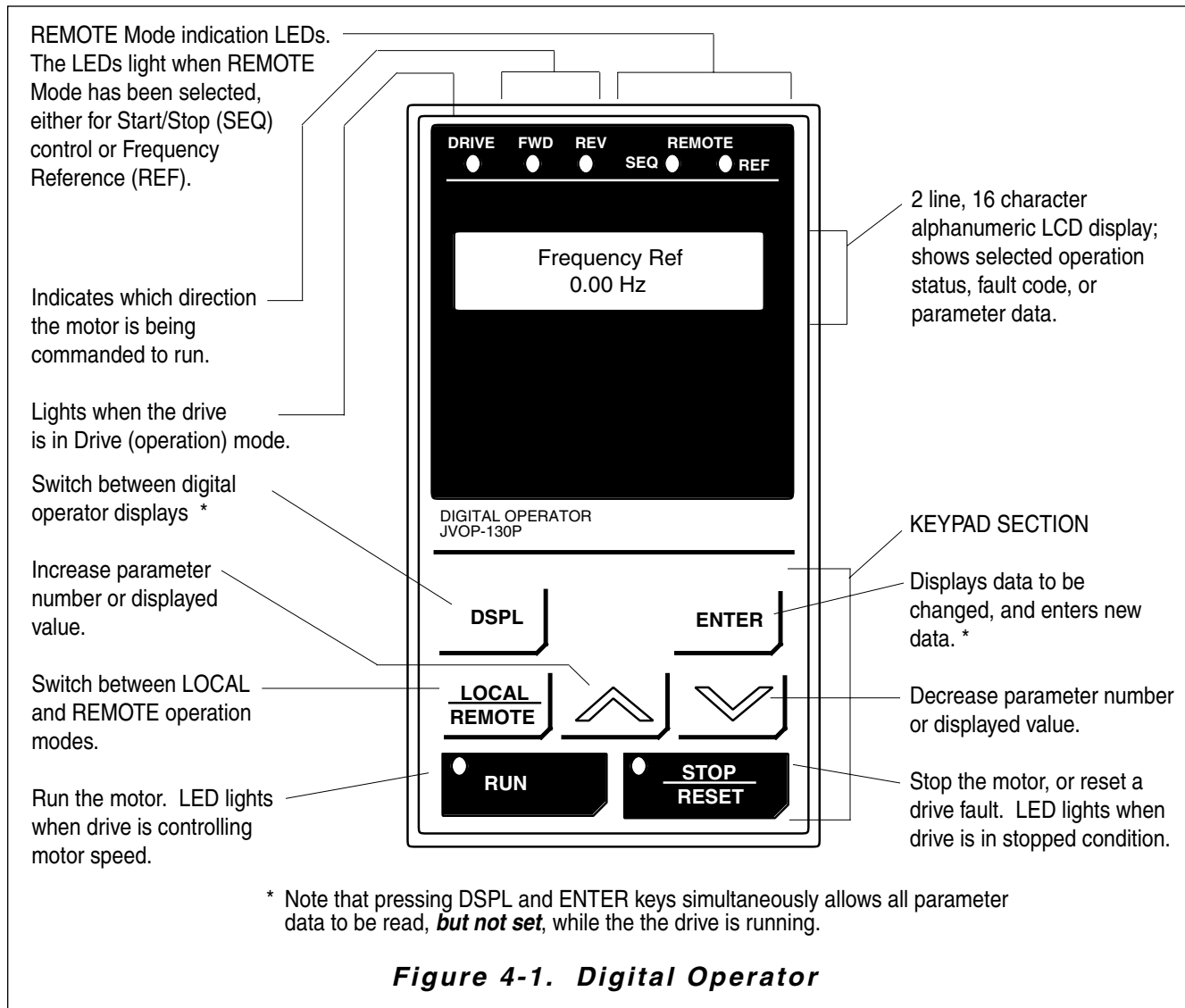

**Figure 4-1. Digital Operator**

## 4.2.1 Description of Quick-Start Displays

By pressing the **DSPL** key on the Digital Operator while the drive is stopped or running, the operator can step to each of the sixteen Quick-Start Displays and its associated display/setting function:

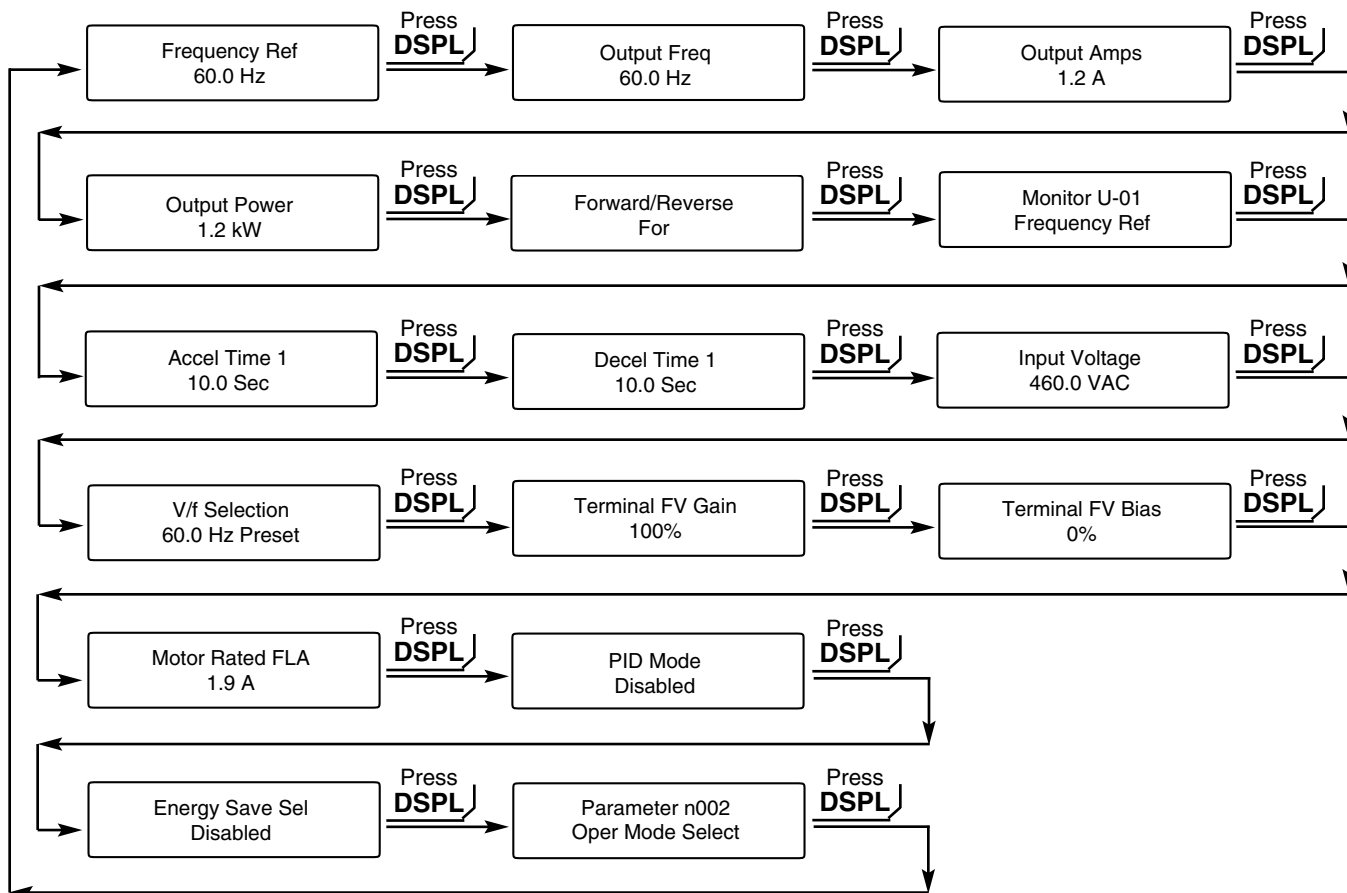

- Frequency Ref** — **Frequency Reference Setting [ n024 ]**  
Sets the drive operation speed (Hz), unless the drive has been programmed for REMOTE Mode operation with run from external analog speed reference signal. Programmable during run.
- Output Freq** — **Output Frequency Monitor**  
Displays the output frequency (Hz) at which the drive is currently operating. This is a **monitor only** function; the operator cannot change the displayed value by use of the keypad.
- Output Amps** — **Output Current Monitor**  
Displays the level of output current (Amps) that the drive is currently producing. This is a **monitor only** function; the operator cannot change the displayed value by use of the keypad.
- Output Power** — **Output Kilowatt Monitor**  
Displays the output power (kW) that the drive is currently producing. This is a **monitor only** function; the operator cannot change the displayed value by use of the keypad.

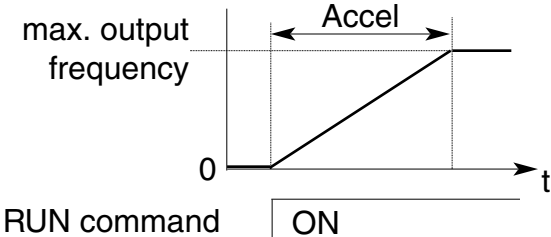
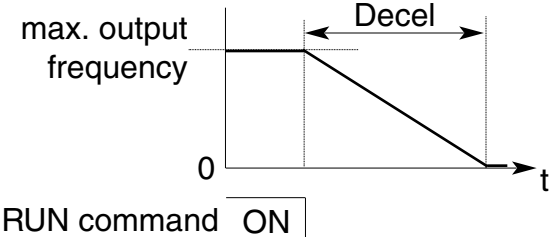
- Forward/Reverse** — **FWD/REV Run Selection**  
 Sets the rotation direction of the motor when a Run command is given by the Digital Operator keypad. Display of **For** = forward run, **rEv** = reverse run. Use of this Quick-Start Display toggles between these two presets; the operator cannot enter a value.
- Monitor U-XX** — **Monitor Selection**  
 Pressing **ENTER** allows access to the various Monitor parameters, **U-01** through **U-13**. These are monitor only functions; the operator cannot change the displayed value. See paragraph 4.4 for list of Monitor parameters. Programmable during run.
- Accel Time 1** — **Acceleration Time 1 [ n018 ]**  
 Sets the time (in seconds) it will take the drive to accelerate the motor from a stopped condition to maximum output frequency (i.e. sets the slope of the accel ramp).  
 Programmable during run.
- 
- Decel Time 1** — **Deceleration Time 1 [ n019 ]**  
 Sets the time (in seconds) it will take the drive to decelerate the motor from maximum output frequency to a stopped condition (i.e. sets the slope of the decel ramp). Programmable during run.
- 
- Input Voltage** — **Motor Rated Voltage [ n013 ]**  
 Sets the rated voltage (V) of the motor. (Part of V/f pattern setup; see paragraph 5.29.)
- V/f Selection** — **V/f Pattern Selection [ n010 ]**  
 Sets a preset V/f pattern or allows a custom V/f pattern to be set for the application. (Part of V/f pattern set-up; see paragraph 5.28.)
- Terminal FV Gain** — **Frequency Reference Gain [ n048 ]**  
 Sets the gain (%) for the analog frequency reference, input at terminal FV; see paragraph 5.10. Programmable during run.
- Terminal FV Bias** — **Frequency Reference Bias [ n049 ]**  
 Sets the bias (%) for the analog frequency reference, input at terminal FV; see paragraph 5.10. Programmable during run.

- Motor Rated FLA** — **Motor Rated Current [ *n033* ]**  
 Sets the Amps used for detecting motor overload. This is normally set to the motor rated current value (nameplate full-load amps). When set to " 0.0 ", motor overload protection is disabled. The factory settings are listed in Appendix 1.
- PID Mode** — **PID Selection [ *n084* ]**  
 Setting data to "Disabled" (" 0 ") (factory setting) disables the PID function. Setting to "Enabled D = Fdbk" (" 1 ") enables PID; setting to "Enabled D = Fdwd" (" 2 ") enables the "Feed Forward" function; setting to "Enabled RevFdbk" (" 3 ") enables the "Inverted PID" function. See "PID Control", paragraph 5.22.
- Energy Save Sel** — **Energy Saving Selection [ *n096* ]**  
 Setting data to "Disabled" (" 0 ") (factory setting) disables the energy saving function; and setting to "Enabled" (" 1 ") enables this function. See "Energy Saving Control", paragraph 5.9.
- Parameter nXXX** — **Parameter Programming**  
 Selects or reads data using parameter number (*nXXX*). Data is displayed by pressing the **ENTER** key, and can be changed by pressing the "up arrow" or "down arrow" keys. Any changes can be saved by again pressing the **ENTER** key. Pressing the **DSPL** key exits the Programming mode.

### 4.3 BASIC PROGRAMMING

By using the Quick-Start Displays on the Digital Operator, simple programming of the drive is possible. Following are examples of two methods for setting the acceleration time (**n018**). The first example shows how to utilize the **Accel** Quick-Start Display, and the second example shows how to access parameter **n018** through the **Program Mode**.

#### EXAMPLE 1: Using Accel Quick-Start Display

	Display
<ul style="list-style-type: none"> <li>Press the <b>DSPL</b> key repeatedly until the " Accel Time 1 " appears.</li> </ul>	<div style="border: 1px solid black; padding: 5px; text-align: center;">                     Accel Time 1 10.0 sec                 </div>
<ul style="list-style-type: none"> <li>To set the acceleration time to 5 seconds, press the "down arrow" key until the Digital Operator display reads " 5.0 ".</li> </ul>	<div style="border: 1px solid black; padding: 5px; text-align: center;">                     Accel Time 1 5.0 sec                 </div>
<ul style="list-style-type: none"> <li>Press the <b>ENTER</b> key.</li> </ul>	<div style="border: 1px solid black; padding: 5px; text-align: center;">                     Accel Time 1 5.0 sec                 </div>

#### EXAMPLE 2: Using Program Mode

<ul style="list-style-type: none"> <li>Press the <b>DSPL</b> key repeatedly until " Parameter n001 " appears.</li> </ul>	<div style="border: 1px solid black; padding: 5px; text-align: center;">                     Parameter n001 Password                 </div>
<ul style="list-style-type: none"> <li>Press the "up arrow" key to access <b>n018</b>.</li> </ul>	<div style="border: 1px solid black; padding: 5px; text-align: center;">                     Parameter n018 Accel Time 1                 </div>
<ul style="list-style-type: none"> <li>Press the <b>ENTER</b> key. The current set value is displayed.</li> </ul>	<div style="border: 1px solid black; padding: 5px; text-align: center;">                     Accel Time 1 10.0 sec                 </div>
<ul style="list-style-type: none"> <li>To set the acceleration time to 15 seconds, press the "up arrow" key until the Digital Operator display reads " 15.0 ".</li> </ul>	<div style="border: 1px solid black; padding: 5px; text-align: center;">                     Accel Time 1 15.0 sec                 </div>
<ul style="list-style-type: none"> <li>Press the <b>ENTER</b> key. Note: Once changed, data will blink until the <b>ENTER</b> key is pressed.</li> </ul>	<div style="border: 1px solid black; padding: 5px; text-align: center;">                     Accel Time 1 15.0 sec                 </div>
<ul style="list-style-type: none"> <li>Press the <b>DSPL</b> key until " Frequency Ref " appears and <b>DRIVE LED</b> turns on.</li> </ul>	<div style="border: 1px solid black; padding: 5px; text-align: center;">                     Frequency Ref 0.0 Hz                 </div>

## 4.4 MONITOR DISPLAYS

When using the **Monitor** Function, a variety of information will appear on the Digital Operator display when each of the U-XX (display only) parameters is selected.

CONSTANT U-	MONITORED ITEM	DISPLAY EXAMPLE
01	Frequency reference (Hz)	<b>Frequency Ref.</b> <b>60.0 Hz</b>
02	Output frequency (Hz)	<b>Output Freq.</b> <b>60.0 Hz</b>
03	Output current (A)	<b>Output Amps</b> <b>12.5 A</b>
04	AC output voltage (V)	<b>Output Voltage</b> <b>230 VAC</b>
05	DC Bus voltage (VPN)	<b>DC Bus Voltage</b> <b>325 VDC</b>
06	Output power (kW)	<b>Output Power</b> <b>(-) 0.7 kW</b>
07	Input terminal status	<b>00101010</b> <sup>(1)</sup>
08	Drive status	<b>01010101</b> <sup>(2)</sup>
09	Fault log (last 4 faults) <sup>(3)</sup>	<b>Fault History</b> <b>oC</b>
10	Software number (last 4 digits) : 10XXXX	<b>PROM Number</b> <b>5110</b> <sup>(4)</sup>
11	Elapsed time meter (Hrs) (lower 4 digits, can be preset in parameter <b>n066</b> )	<b>Elapsed Time 1</b> <b>3456 H</b>
12	Elapsed time meter (Hrs) (upper 2 digits, can be preset in parameter <b>n062</b> )	<b>Elapsed Time 2</b> <b>12 H</b>
13	PID feedback (Hz)	<b>45.0</b>
14	Square root function	<b>Square Root N</b> <b>7557</b>
15	Kilowatt-hour meter (lower 4 digits)	<b>KwH Monitor 1</b> <b>0.1 KwH</b>
16	Kilowatt-hour monitor (upper 2 digits)	<b>KwH Monitor 2</b> <b>0</b>

(1) Actual display appearance:

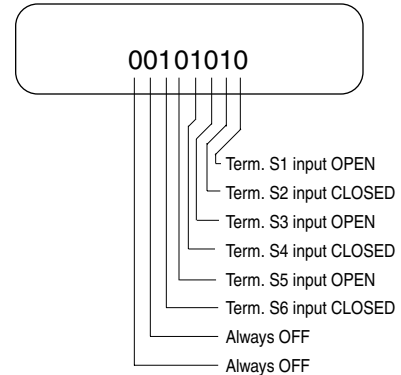

(2) Actual display appearance:

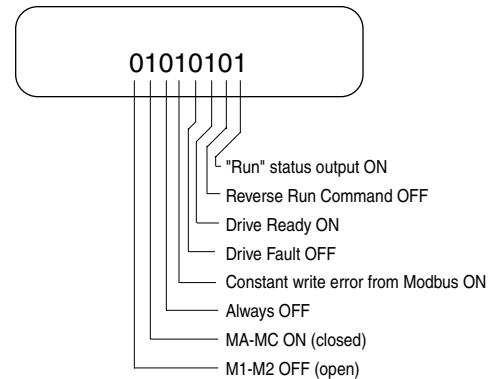

(3) See paragraph 6.2 for viewing of fault log contents.

(4) "5110" for 230V drives up to GPD506V-A068 (CIMR-P5M20151F) and 460V drives up to GPD506V-B034 (CIMR-P5M40151F)

"5120" for 230V drives GPD506V-A080 (CIMR-P5M20181F) and above, and 460V drives GPD506V-B041 (CIMR-P5M40181F) and above

"5130" for all 575V drives

# Section 5. PROGRAMMABLE FEATURES

## 5.1 GENERAL

This section describes features of the drive which are defined by programmed settings in the various parameters in memory. Since most features use more than one parameter, the descriptions appear in alphabetical order by the function name. In Table 5-1, the functions are grouped into operational categories. To cross reference a particular parameter to the features to which it applies, see the listings in Appendix 1, or the Index.

**Table 5-1. List of Features Defined By Parameters**

<b>FUNCTION</b>	<b>PARAGRAPH REFERENCE</b>	<b>PARAMETER(S)</b>
<b>SET-UP</b>		
Initialization (Reset), 2-Wire or 3-Wire	5.23	<i>n001</i>
Drive Capacity, Parameters Affected By	Table A3-1	—
Volts/Hertz Patterns, Standard	5.28 A	<i>n010</i>
Volts/Hertz Pattern, Custom	5.28	<i>n011 - n017</i>
Input & Output Voltage Setting	5.28 B	<i>n003</i>
Thermal Motor Overload Protection	5.26	<i>n033, n034</i>
Digital Operator Display, Re-scaling	5.8	<i>n023</i>
Input Phase Loss Detection	5.29	<i>n083</i>
<b>STARTING</b>		
Accel Time	5.2	<i>n018, n020</i>
S-Curve Characteristics	5.3	<i>n022</i>
DC Injection Braking at Start	5.7	<i>n016, n068, n070</i>
<b>STOPPING</b>		
Stopping Method	5.25	<i>n004</i>
Decel Time	5.2	<i>n019, n021</i>
DC Injection Braking at Stop	5.7	<i>n016, n068, n069, n070</i>
Local/Remote Changeover	5.15.1	<i>n111</i>
<b>SPEED CONTROL</b>		
Frequency Reference, Upper & Lower Limits	5.12	<i>n031, n032</i>
Jog Reference	5.15	<i>n030, n036 - n040</i>
Speed Reference Selection (Remote/Local)	5.19A	<i>n002</i>
Multi-step Speed Setting	5.19B	<i>n024 - n030, n037 - n040</i>
Sample/Hold	5.19G	<i>n036 - n040</i>
Accel/Decel/Hold	5.19H	<i>n036 - n040</i>
Up/Down Frequency Setting	5.19H	<i>n040</i>

**Table 5-1. List of Features Defined By Parameters - Continued**

<b>FUNCTION</b>	<b>PARAGRAPH REFERENCE</b>	<b>PARAMETER(S)</b>
<b>SPEED CONTROL (continued)</b>		
Modbus Control	5.16	<i>n002, n036 - n040, n101- n106</i>
PID Control	5.22	<i>n002, n024 - n030, n043, n044, n084 - n093, n094, n095</i>
<b>REVERSE</b>		
Reverse Run Disabled	Table A1-1	<i>n006</i>
<b>RUNNING</b>		
Critical Frequency Rejection	5.6	<i>n062, n063, n064</i>
Carrier Frequency	5.5	<i>n054</i>
Speed Search	5.19E	<i>n036 - n040, n056 - n058</i>
Speed Coincidence	5.20B	<i>n075, n076</i>
Energy Saving	5.9	<i>n096 - n100</i>
Slip Compensation	5.23.1	<i>n107 - n109</i>
<b>RUNNING IMPROVEMENTS</b>		
Torque Compensation	5.27	<i>n071</i>
Stall Prevention	5.24	<i>n072, n073, n074</i>
<b>PROTECTIVE FEATURES</b>		
Momentary Power Loss Ride-thru	5.17	<i>n055, n059</i>
Auto Restart	5.4	<i>n060, n061</i>
Frequency Reference Loss Detection	5.13	<i>n046, n047</i>
Frequency Reference Retention	5.14	<i>n045</i>
Overtorque/Undertorque Detection	5.21	<i>n041, n042, n077, n078, n079</i>
Miscellaneous Protective Functions	5.16.1	<i>n110</i>
Timer Function	5.19 F	<i>n041, n042, n080, n081</i>
<b>DRIVE CONTROLS, INPUT</b>		
Multi-function Analog Input (Auto/Manual)	5.11	<i>n043, n044</i>
Frequency Reference Bias and Gain	5.10	<i>n048 - n051</i>
Multi-function Input Terminals	5.19	<i>n036 - n040</i>
External Fault Terminals	5.19	<i>n036 - n040</i>
<b>DRIVE OUTPUT</b>		
Multi-function Output Terminals	5.20	<i>n041, n042, n075, n076</i>
Analog Monitor Output (Multi-function)	5.18	<i>n052, n053</i>
<b>MONITOR DISPLAY</b>		
Digital Operator Display Selection	5.8	<i>n023</i>



## 5.2 ACCEL/DECEL TIME

- A. **n018** : Accel Time 1  
**n019** : Decel Time 1

Factory setting (each): <b>10.0</b> seconds
Range (each): 0.0 to 3600 seconds

- n020** : Accel Time 2  
**n021** : Decel Time 2

Factory setting (each): <b>10</b> seconds
Range (each): 0 to 255 seconds

The Drive incorporates two sets of individually programmable acceleration and deceleration times.

- B. **n036** thru **n040** : Multi-function Inputs (Term. S2 thru S6)

Data <b>14</b> : Accel/Decel Time Selection
---

By programming data "Acc/Dec Switch" (" 14 ") into one of the multi-function parameters (**n036** thru **n040**), one of the multi-function input terminals (S2 thru S6) becomes a time selection input. When the input terminal (i.e. external contact) is open, Time 1 (**n018** / **n019**) is selected. When the input terminal is closed, Time 2 (**n020** / **n021**) is selected.

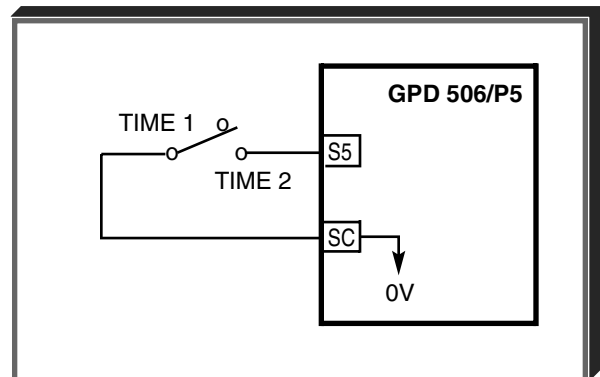

*Note:* All tables for parameters with "selectable" data (**n002**, **n004**, etc.) show the factory setting indicated in **bold**, followed by an asterisk (\*).

### 5.3 ACCEL/DECEL: S-CURVE CHARACTERISTICS

#### n022 : S-Curve Selection (S-Curve Select)

Setting of this parameter determines the S-curve (starting) characteristics of the acceleration ramp.

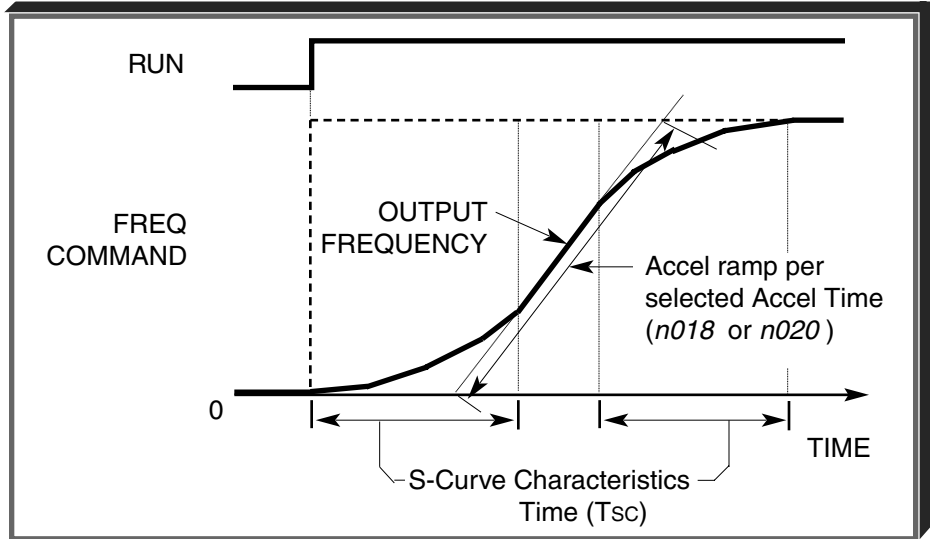

LED Setting	LCD Setting	Description
0	No S-Curve *	S-Curve disabled
1	0.2 Sec	S-Curve of 0.2 seconds
2	0.5 Sec	S-Curve of 0.5 seconds
3	1.0 Sec	S-Curve of 1.0 seconds

The following figure shows FWD/REV switching and acceleration & deceleration to a stop with S-curve active.

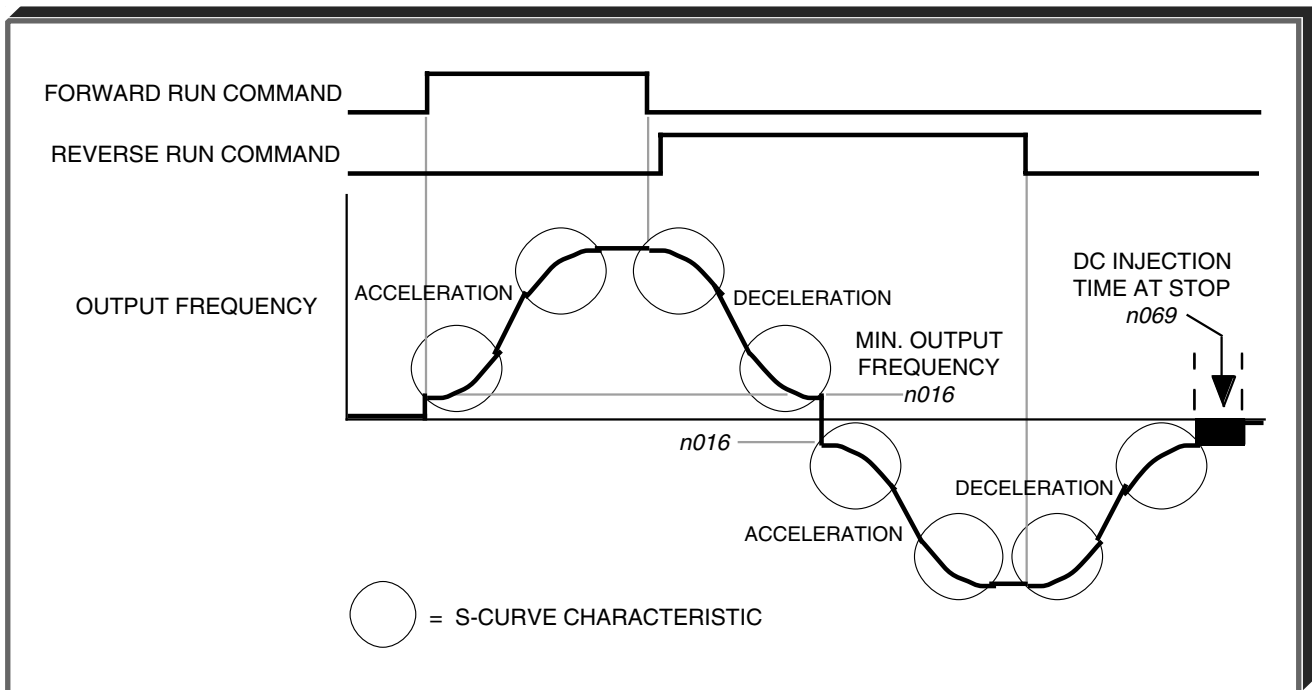

## 5.4 AUTO-RESTART

**A. n060 :** Number of Auto-Restart Attempts  
(Num of Restarts)

Factory setting: **0**

Range: 0 - 10

When a fault occurs during operation, the drive can be programmed for an auto-restart operation to automatically reset the fault. Auto-restart operation will use the number of reset attempts set in this parameter, up to the maximum of 10. When set to "0", no auto-restarts will be attempted.

- The following faults can be automatically reset:
  - oC: Overcurrent                      GF: Ground fault
  - ou: Overvoltage (OV)                Uu1: Undervoltage (Power UV)
- The following conditions WILL NOT initiate auto-restart:
  - oL, EF\_ , PUF or CPF\_ fault.
  - When OC or UV occurs during deceleration.
  - When **n055** is programmed to stop during momentary power failure (data = "0"). (See paragraph 5.17, **MOMENTARY POWER LOSS RIDE-THRU.**)
- The number of restart attempts available will be reset to the **n060** setting when:
  - 10 minutes has elapsed without a fault occurring.
  - The **RESET** key, or external Fault Reset push button, is pressed.
  - Power is removed from the Drive.

**B. n061 :** Fault Contact Status During Auto-Restart (Restart Sel)

This digit controls how the fault contact responds to a drive fault during the auto-restart operation.

LED Setting	LCD Setting	Description
0 *	Activate Flt Fly *	Fault contract actuates during auto-restart attempts
1	No Rly Output	Fault contract will not actuate during auto-restart attempts

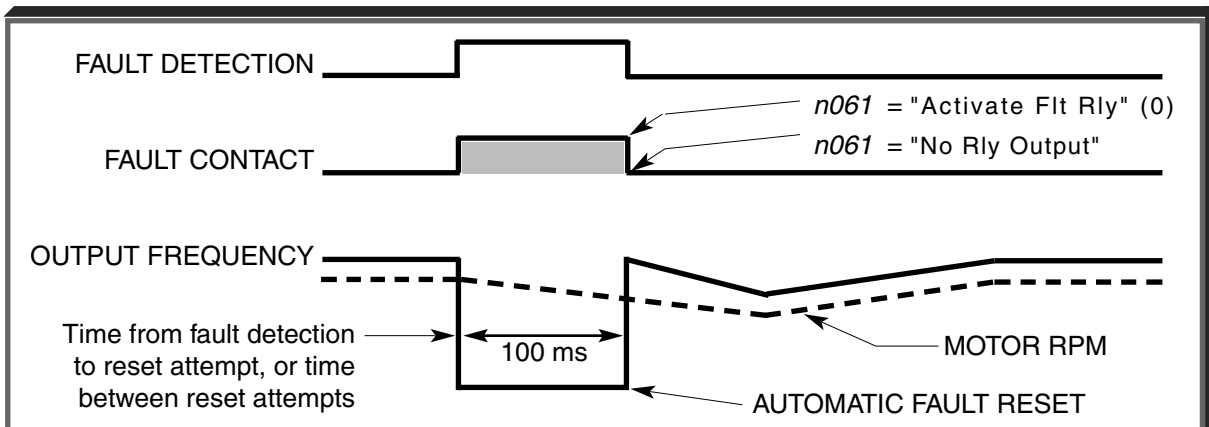

**Auto-Restart Operation Timing**

## 5.5 CARRIER FREQUENCY

### **n054** : Carrier Frequency Upper Limit (Carrier Freq Sel)

The relationship between output frequency and carrier frequency is determined from the set value of **n054**.

- (a) For constant carrier frequency, set to "2.5 kHz" through "15.0 kHz."  
 (b) For synchronous mode, set **n054** to "synchronous 1, 2, or 3" (7 ", " 8 ", or " 9 ").  
 These setting values establish carrier frequencies of 12f, 24f, or 36f, respectively.

LED SETTING	LCD SETTING	CARRIER FREQUENCY (kHz)		SLOPE ( = $F_c$ ) $F_o$	OUTPUT FREQUENCY (Hz)		MODE
		Maximum ( $F_{cMAX}$ )	Minimum ( $F_{cMIN}$ )		F1	F2	
1	2.5 kHz	2.5	2.5	0	NA	NA	CONSTANT
2	5.0 kHz	5.0	5.0	0	NA	NA	
3	8.0 kHz	7.5	7.5	0	NA	NA	
4	10.0 kHz	10.0	10.0	0	NA	NA	
5	12.5 kHz	12.5	12.5	0	NA	NA	
6	15.0 kHz	15.0	15.0	0	NA	NA	
7	Synchronous 1	2.5	1.0	12	83.3	208.3	SYNCHRONOUS
8	Synchronous 2	2.5	1.0	24	41.6	104.1	
9	Synchronous 3	2.5	1.0	36	27.7	69.4	
10†	7.0 kHz	7.0	7.0	0	NA	NA	CONSTANT

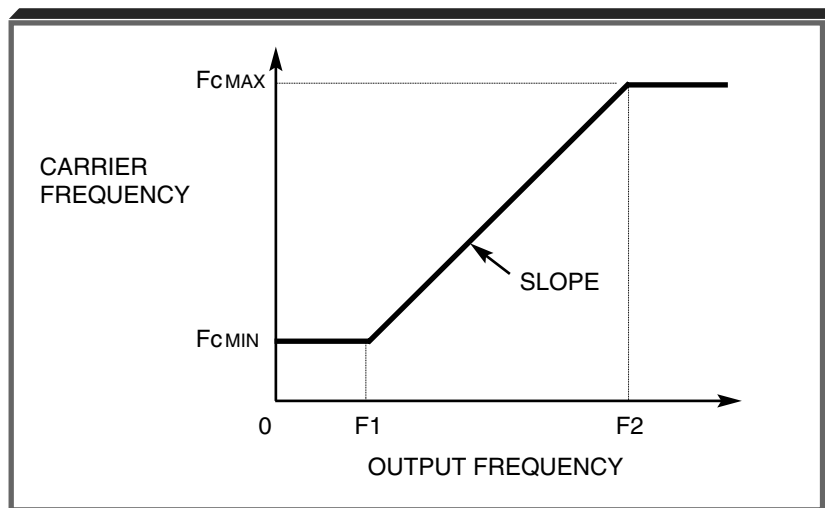

† Setting of " 10 " is available only on GPD 506V - B096 (CIMR-P5M40451F).

Maximum carrier frequency and factory setting are dependent upon drive rating; see Appendix 3.

Carrier frequency should be decreased as the distance between the drive and the motor increases, to reduce capacitive coupling in the motor leads.

- For wiring distances up to 50m (164 ft.), **n054** should be set to "15.0 kHz" (data " 6 " ) or less.
- For wiring distances from 50m (164 ft.) to 100m (328 ft.), **n054** should be set to "10.0 kHz" (data " 4 " ) or less.
- For wiring distances greater than 100m (328 ft.), **n054** should be set to "5.0 kHz" (data " 2 " ) or less.

## 5.6 CRITICAL FREQUENCY REJECTION

- A. **n062** : Prohibited Frequency 1 (Jump Freq 1)  
**n063** : Prohibited Frequency 2 (Jump Freq 2)

Factory setting (each): **0.0**

Range (each): 0.0 to 400.0 Hz

These parameters allow programming of up to two prohibited frequency points for eliminating problems with resonant vibration of the motor/machine. This feature does not actually eliminate the selected frequency values, but will accelerate and decelerate the motor through the prohibited bandwidth.

- B. **n064** : Prohibited Frequency Deadband  
(Jump Bandwidth)

Factory setting: **1.0**

Range: 0.0 to 25.5 Hz

This parameter determines the width of the deadband around each selected prohibited frequency point. The factory setting is " 1.0 ", which establishes a deadband of  $\pm 1.0$  Hz.

### EXAMPLE:

Vibration encountered between 30.0 and 36.0 Hz.

SOLUTION: Set **n062** to " 33.0 ". This is the center of the problem frequency band.

Set **n064** to " 3.0 ". This will cause the drive to reject all frequency command values between 30.0 and 36.0 Hz.

A frequency command in the deadband will be converted to the bottom value of the deadband, e.g. a command of 33 Hz would result in a run frequency of 30 Hz.

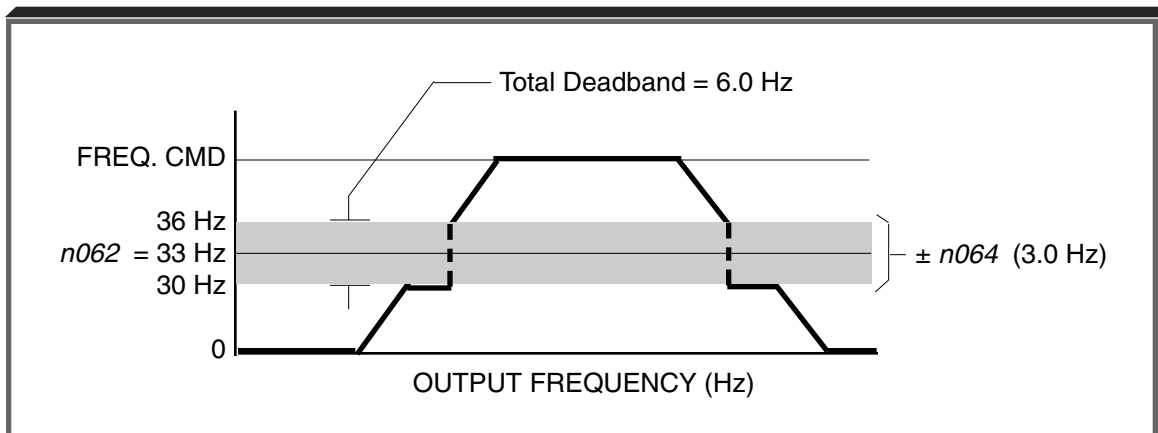

Note that if  $n062 \leq n063$  is not satisfied, the Digital Operator displays the parameter setting error code " **OPE6** Parameter Error", except when **n063** equals zero.

## 5.7 DC INJECTION BRAKING

<b>n016</b> : Minimum Frequency (Min Frequency)	Range: 0.1 to 10.0 Hz
<b>n068</b> : DC Injection Braking Current (DC Inj Current) (% of Drive Rated Current)	Factory setting: <b>50</b> % Range: 0 to 100 %
<b>n069</b> : DC Injection Time at Stop (DC Inj Time@Stop)	Factory setting: <b>0.0</b> sec Range: 0.0 to 10.0 sec
<b>n070</b> : DC Injection Time at Start (DC Inj Time@Start)	Factory setting: <b>0.0</b> sec Range: 0.0 to 10.0 sec

DC injection can be used to stop a motor whose rotational direction is uncertain at start-up, or to help stop a coasting motor.

With ramp to stop enabled (**n004** = "Ramp to Stop" ("0")), after a STOP command is received the drive controls motor deceleration according to the Decel Time setting, until output frequency reaches the DC injection braking start frequency (or Minimum Frequency, **n016**). Then the drive output is turned off and DC injection current is applied to the motor. The effective DC injection time and current should be set to provide adequate stopping without excessive motor heating. The DC injection voltage is determined by the DC injection braking current and motor impedance.

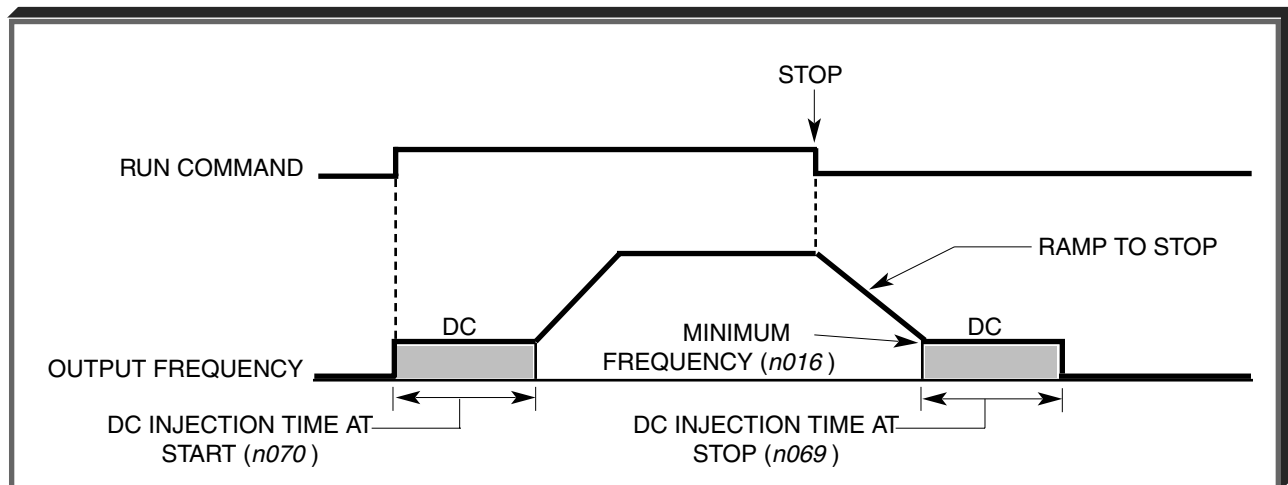

**DC Braking Sequence**

## 5.8 DIGITAL OPERATOR DISPLAY SELECTION

**n023** : Operator Display Mode  
Reference and Indication (Display Units)

Factory setting: **0**

Range: 0 to 4999

This parameter determines the scaling of the Digital Operator display, for both Output Frequency and all Frequency References.

DATA	DISPLAY
<b>0*</b> (factory setting)	Output frequency, in increments of 0.1 Hz.
1	Output frequency, in increments of 0.1 %.
2 to 39 (no. of motor poles)	<p>Motor synchronous speed (<math>P = \frac{120 \times F}{N_s}</math>) in increments of 1 RPM (3999 max).</p> <p>P = no. of motor poles F = Frequency N<sub>s</sub> = motor synchronous speed</p> <p>NOTE: If motor synchronous speed exceeds 3999 RPM, display holds at <b>3999</b> .</p>
40 to 4999	<p>Line speed or other parameter.</p> <p><u>X X X X</u></p> <p>Parameter value at maximum frequency (<b>n011</b>) (include leading zeroes if necessary)</p> <p>Location of decimal point:</p> <p>_ = _ X X X  <b>1</b> = X X X. X  <b>2</b> = X X. X X  <b>3</b> = X. X X X  <b>4</b> = X. X X 0          ( X X X *10)</p> <p>(See <b>CAUTION</b> on next page)</p> <p><b>EXAMPLE:</b></p> <p>To display Line Speed, based on 54.3 FPM at 60 Hz:</p> <p><b>n023</b> setting = " <b>1543</b> "</p>

Exceptions to the general format are as follows:

<u><i>n 023</i></u>		<u>DISPLAY</u>
" <i>1 0 0 0</i> "	=	<i>1 0 0 . 0</i>
" <i>2 0 0 0</i> "	=	<i>1 0 . 0 0</i>
" <i>3 0 0 0</i> "	=	<i>1 . 0 0 0</i>

 **CAUTION**

When setting a value in *n023*, the decimal point position selected will also automatically affect all of the Frequency Reference Memory Settings (*n024 thru n030* ; see Table A1-1).

**EXAMPLE:**

*n 023* factory setting: *0 0 0 0*

*n 030* (Jog) factory setting: *0 0 6 . 0* (6 Hz)

*n 023* changed to *2 0 6 0*

└─── Decimal point at X X.X X

*n 030* setting becomes *0 . 0 6*

Therefore, for 10.00 Hz Jog frequency, *n 030* must be reprogrammed to *0 . 1 0*



## 5.9 ENERGY SAVING CONTROL

**n096** : Energy Saving Selection (Energy Save Sel)

LED Setting	LCD Setting
0*	Disabled*
1	Enabled

To enable energy saving control, **n096** must be set to "Enabled" (" 1 ").

Since the parameters used in the energy saving control mode have been preset to the optimum values, it is not necessary to adjust them under normal operation. If your motor characteristics differ greatly from those of a standard motor, refer to the following description to change the parameters.

### A. Energy Saving Control Mode

**n097** : Energy Saving Gain K2  
(Energy Save Gain)

Factory setting: *See Table A3-1*

Range: 0.00 to 655.0

The drive uses this gain when running in the energy saving control mode to calculate the voltage at which motor efficiency will be greatest, and sets it as the output voltage reference. This value is preset to a typical standard motor value. As energy saving gain increases, output voltage also increases.

**n098** : Energy Saving Voltage Lower Limit  
at 60Hz (EngSavVlmt@60Hz)

Factory setting: **75** %

Range: 0 to 120 %

**n099** : Energy Saving Voltage Lower Limit  
at 6Hz (EngSavVlmt@6Hz)

Factory setting: **12** %

Range: 0 to 25 %

Sets the output voltage lower limit. If the voltage reference value calculated in the energy saving mode is below the specified lower limit, this lower limit value is used as the voltage reference value. The lower limit value is set to prevent stalling at light loads. Set voltage limits at 6Hz and 60Hz; a value obtained by linear interpolation should be set to any limit values other than at 6Hz or 60Hz. Setting is made as a percentage of motor rated voltage.

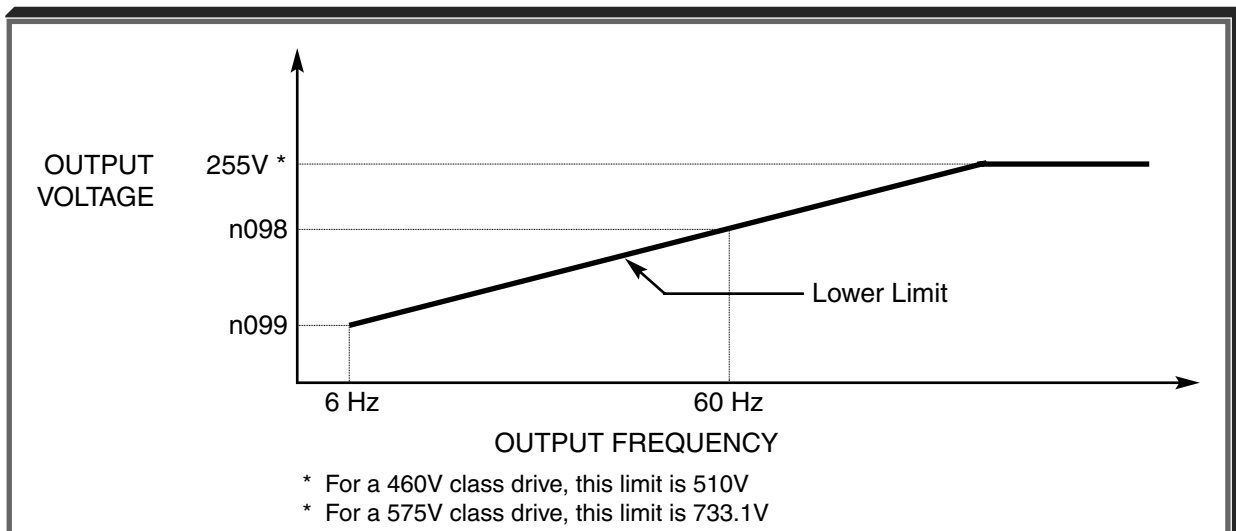

## 5.9 ENERGY SAVING CONTROL

Continued

### B. Energy Saving Tuning

In the energy saving control mode, the optimum voltage is calculated according to load power, and this voltage is supplied to the load. However, since the set parameter may change due to temperature variations or using other manufacturers' motors, the optimum voltage may not necessarily be supplied. Automatic tuning controls the voltage so that highly efficient operation is maintained.

**n100** : Time of Average kW  
(EngSavTime/Avg/kW)

Factory setting: <b>1</b>
---------------------------

Range: 1 to 200 (x 25 ms)
---------------------------

Sets adjustment time of kW saving. By increasing this value, the response time to a change in load is increased, which may prevent the system from oscillating. However, too long of a response time may starve the motor of voltage.

## 5.10 FREQUENCY REFERENCE BIAS/GAIN

**n048** : Terminal FV Gain

Factory setting: **100** %

Range: 0 to 200 %

Sets the auto-speed frequency command gain, in increments of 1%.

**n049** : Terminal FV Bias

Factory setting: **0** %

Range: -100 to 100 %

Sets the auto-speed frequency command bias, in increments of 1%.

**n050** : Terminal FI Gain

Factory setting: **100** %

Range: 0 to 200 %

**n051** : Terminal FI Bias

Factory setting: **0** %

Range: -100 to 100 %

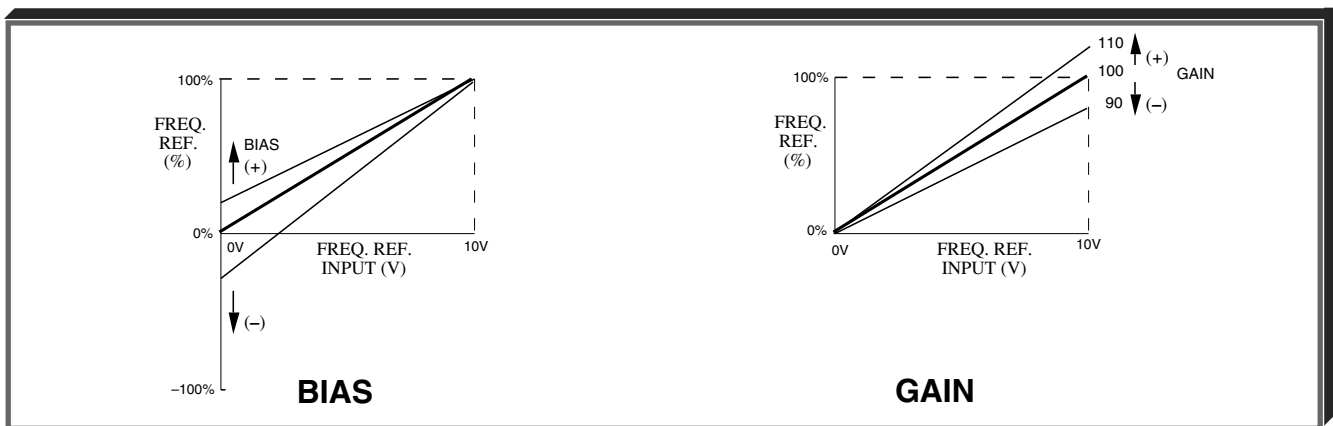

### ADJUSTMENT PROCEDURE:

- A. For 0-10 Vdc input (term. FV)
  1. With no input, adjust Bias (**n049** setting) until an output of 0.0 Hz is obtained.
  2. With full scale input, adjust Gain (**n048** setting) until an output of 60.0 Hz (or other desired max. output frequency) is obtained.
- B. For 4-20mA input (term. FI)
  1. With 4mA input, adjust Bias (**n050** setting) until an output of 0.0 Hz is obtained.
  2. With 20mA input, adjust Gain (**n051** setting) until an output of 60.0 Hz (or other desired max. output frequency) is obtained.

### NOTE

Follow the same adjustment procedure for other desired frequency setpoints.

## 5.10 FREQUENCY REFERENCE BIAS/GAIN

Continued

- C. For inverse-acting frequency reference
1. Begin with **n048** & **n049** settings as shown below.
  2. Fine tune as indicated in A or B above.

Frequency reference inputs:  
 terminals FV & FC — 0-10 VDC  
 terminals FI & FC — 4-20 mA

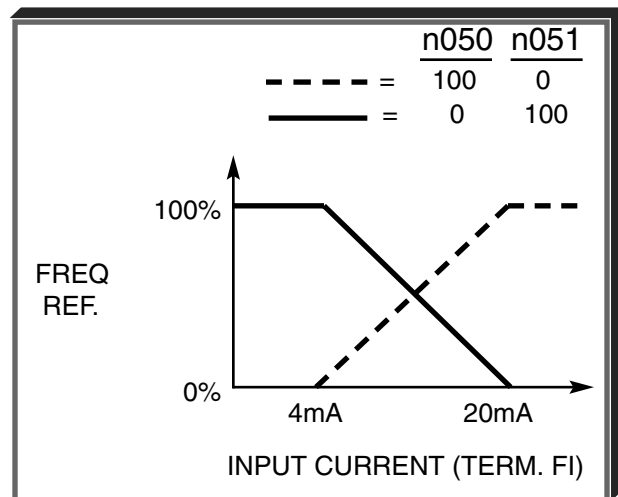
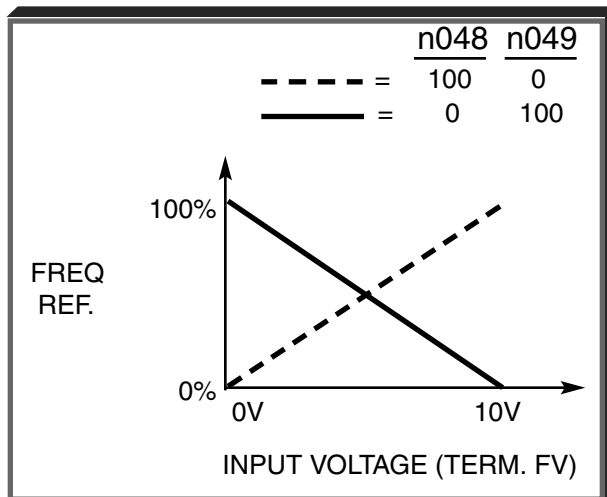
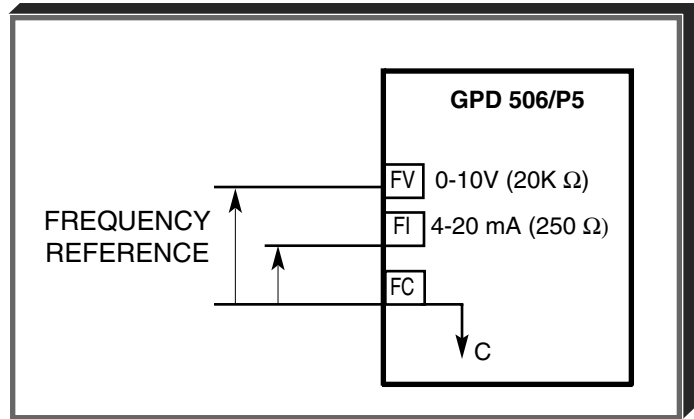

## 5.11 FREQUENCY REFERENCE INPUT SIGNALS (AUTO/MANUAL)

### **n043** : Analog Input Selection (AnalogInput Sel)

To input an auto frequency reference from external terminals, program **n043** to "FV=MSTR FI=AUX" ("0") for a voltage reference (0 to 10V) or to " FV=AUX FI=MSTR " ("1") for a current reference (4 to 20mA).

LED Setting	LCD Setting	Terminal FV Function	Terminal FI Function	FV/FI Switching Allowed <sup>(1)</sup>
0*	FV=MSTR FI=AUX*	Auto Speed Reference	Manual Speed Reference	Yes
1	FV=AUX FI=MSTR	Manual Speed Reference	Auto Speed Reference	Yes
2	FV=RST FI=MSTR <sup>(3)</sup>	Fault Reset <sup>(2)</sup>	Auto Speed	No
3	FV=MSTR FI=SQRT	Auto Speed Reference	$\sqrt{N}$	No
4	FV=RST FI=SQRT	Fault Reset**	$\sqrt{N}$	No

- (1) A Multi-function input can be programmed to switch the analog terminal function. This is accomplished by programming a multi-function input parameter (**n036** thru **n040**) to = "Master Fref Sel"("9"). Note that if **n043** is then set to "FV=RST FI=MSTR" ("2"), an OPE6 fault will occur.
- (2) A fault reset will occur when the voltage on this terminal exceeds 6.0V.
- (3) When **n043** is set to "FV=RST FI=MSTR" ("2") and PID selection **n084** is NOT disabled (set to anything other than "Disabled"("0")) an OPE6 fault will occur.

### **n044** : Terminal FI Signal Level Selection (Terminal FI Sel)

To change the control circuit terminal FI input level, program **n044** .

LED Setting	LCD Setting	Terminal FI Signal Level
0	0-10VDC	0 to 10 V input
1*	4-20mA*	4 to 20 mA input

NOTE: In addition to setting parameter **n044** to "0-10VDC" (" 0 ") for a voltage input, jumper J1 on the drive Control PCB must be cut.

Examples of wiring the drive for frequency references from various sources are shown on the next page.

## 5.11 FREQUENCY REFERENCE INPUT SIGNALS (AUTO/MANUAL)

Continued

A. Speed pot or 0-10VDC signal only:

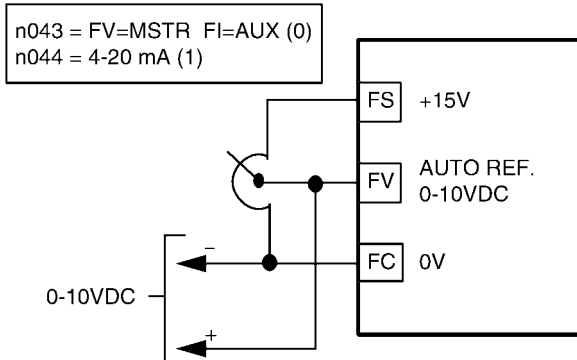

B. 4-20mA signal only:

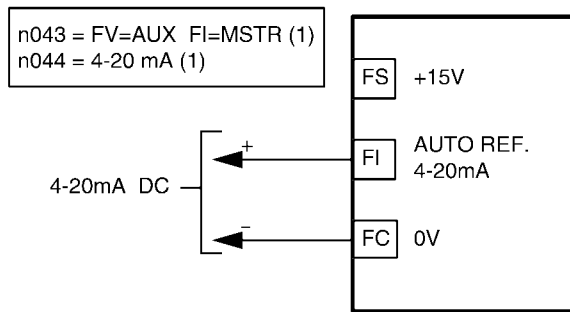

C. 0-10VDC signal (auto) and speed pot (manual):

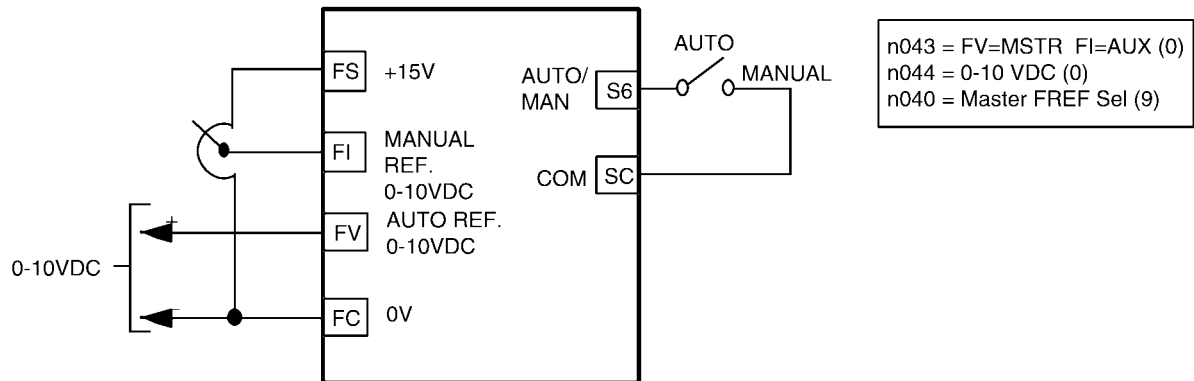

D. 4-20mA DC signal (auto) and 0-10VDC signal or speed pot (manual):

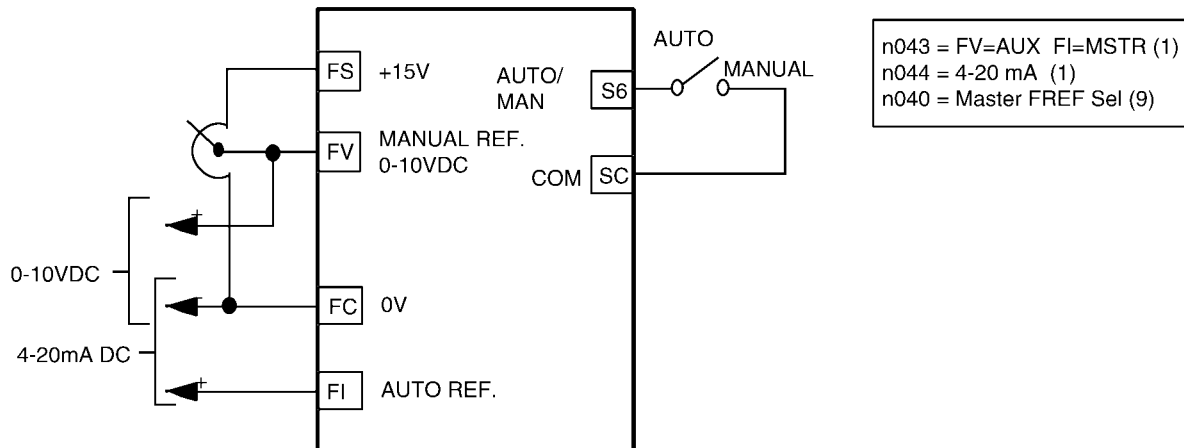

## 5.12 FREQUENCY REFERENCE UPPER & LOWER LIMITS

**n031** : Frequency Reference Upper Limit  
(Ref Upper Limit)

Factory setting: **100** %

Range: 0 to 109 %

**n032** : Frequency Reference Lower Limit  
(Ref Lower Limit)

Factory setting: **0** %

Range: 0 to 100 %

These two parameters set the range for the frequency command signal. Each is set, in increments of 1%, as a percentage of maximum frequency ( $F_{max}$ ; **n011**) as established by either the selected standard V/f pattern or custom V/f pattern.

NOTE: All references are affected by the upper and lower limit points.

### EXAMPLE:

**n011** = " 60 " Hz (100%)

**n031** = " 80 " % = 48Hz – Max. speed

**n032** = " 10 " % = 6Hz – Min. speed

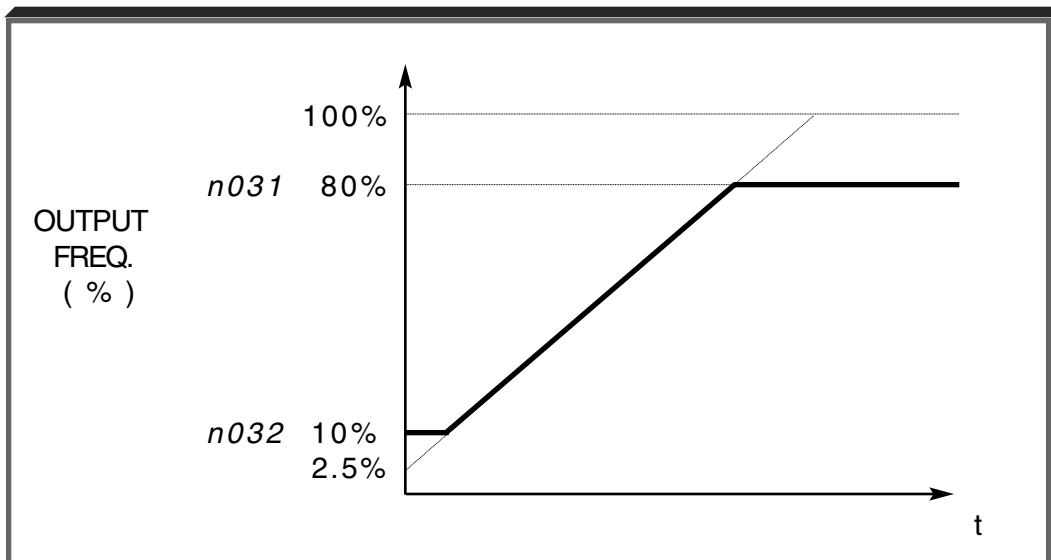

## 5.13 FREQUENCY REFERENCE - LOSS DETECTION

**n046** : Frequency Reference Loss Detection  
(Ref Loss Detect)

**n047** : Frequency Reference Level at Loss  
of Frequency Detection  
(Fref Lvl@FLoss)

Factory setting: **80%**

Range: 0 - 100%

LED Setting	LDC Setting	Terminal FI Signal Level
0 *	0-10 VDC*	0 to 10 V input
1	4-20mA	4 to 20 mA input

The reference loss detection function is either enabled or disabled, based on the setting of **n046**. When enabled (**n046** = "RUN @ **n047** Freq" (" 1 ")), the reference loss detection compares the change in reference with respect to time. If the reference decreases by 90% in more than 0.4 seconds, the drive will decelerate to the set reference; if the reference decreases by 90% in less than 0.4 seconds, the drive will continue to operate at a percentage of the output frequency. This percentage can be set in parameter **n047**. To regain control of output frequency, either exceed the set reference (**n047** \* original frequency reference) or initiate a STOP command. If Auto Reference is less than  $F_{max}$  (**n011**) x .05, this function is not performed.

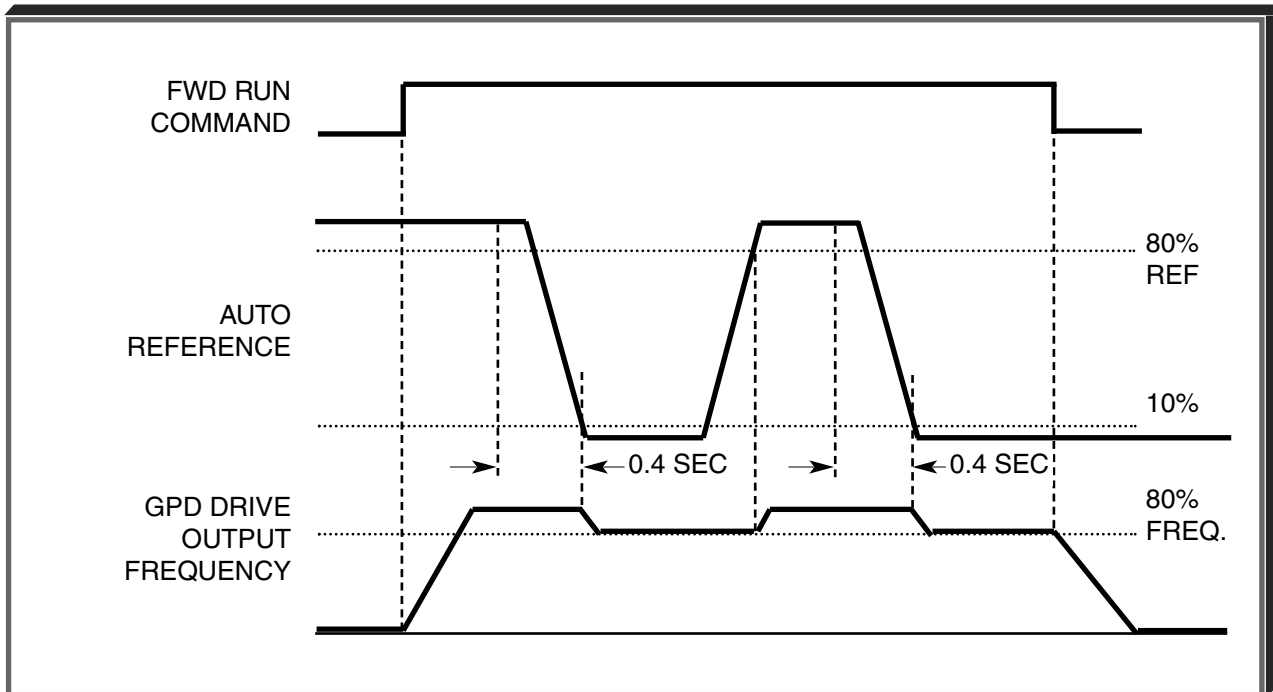

*Time Chart*



## 5.14 FREQUENCY REFERENCE RETENTION

**n045** : Frequency Reference Retention  
(MOP Ref Memory)

Useable with the Up/Down or Sample/Hold commands when either is used as a multi-function contact input. To retain the held frequency reference in **n024** when power is removed, set **n045** to "Memorize FREF" (" 1 ").

LED Setting	LCD Setting	Description
0*	Memorize FREF*	Held reference in Frequency Reference 1 ( <b>n024</b> )
1	Not Memorized	Not Retained

## 5.15 JOG REFERENCE

*n030* : Jog Reference

Factory setting: **6.0** Hz

Range: 0.0 to 400.0 Hz

*n036* thru *n040* : Multi-function Inputs  
(Term. S2 - S6 Sel)

Data : Jog Command (13)

When jog operation is selected (by external Jog and Run signals), the drive output will ramp to the output level set by this parameter.

When an external Jog signal is present, it will override the existing operation mode and the drive will ramp to the level set by this parameter.

### EXAMPLE:

#### OPERATION BY REMOTE SIGNAL INPUT (RUN & JOG)

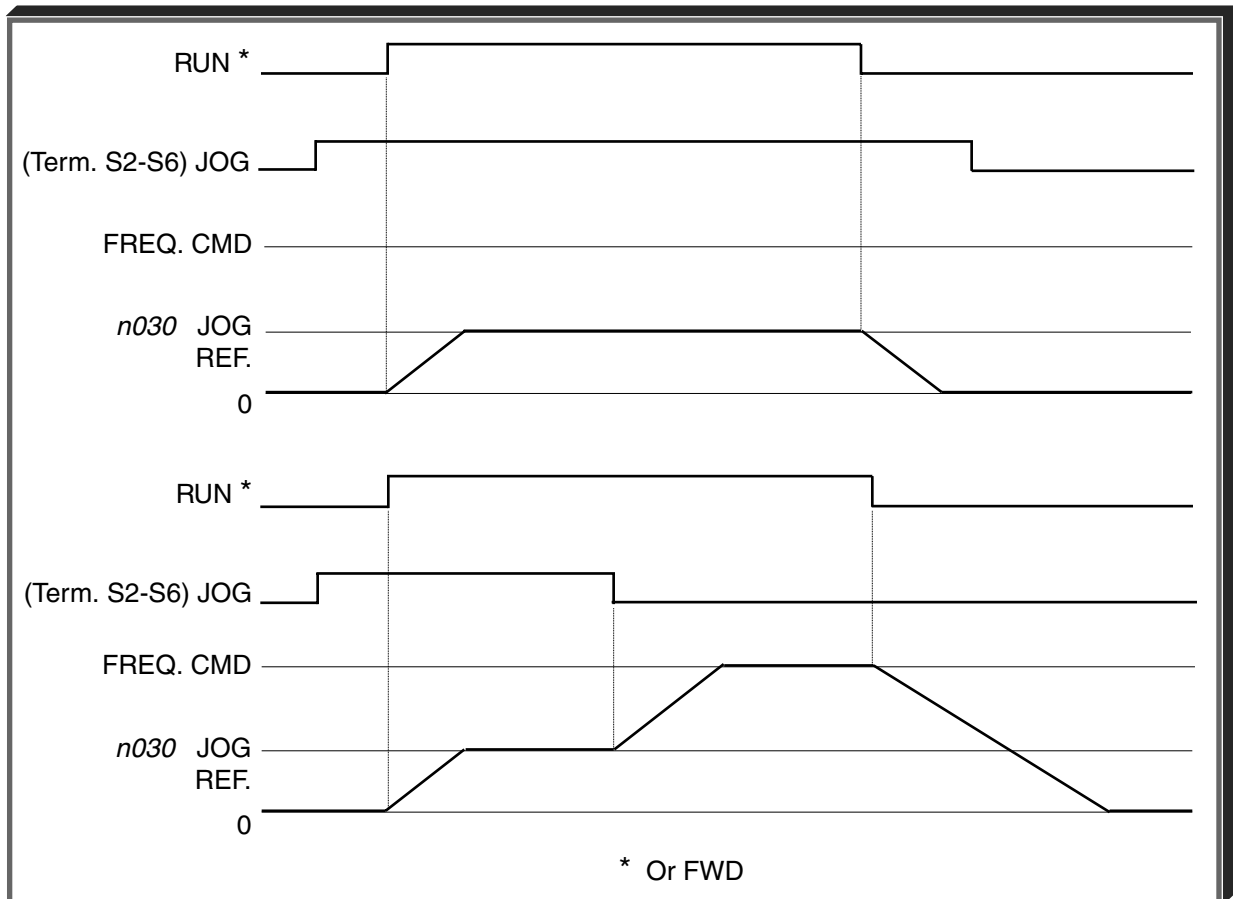

Also see descriptions of **MULTI-FUNCTION INPUT TERMINALS**, paragraph 5.19.

## 5.15.1 LOCAL/REMOTE CHANGEOVER

### *n111* : Local/Remote Changeover

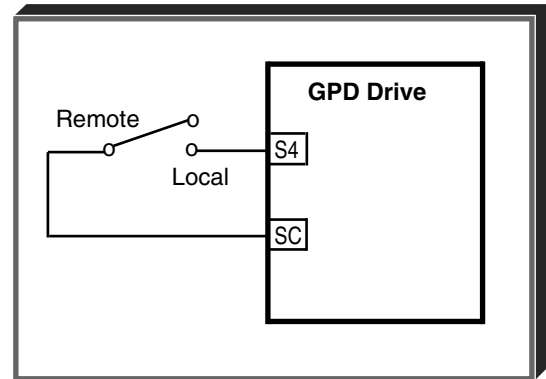

LED Setting	LCD Setting	Description
0 *	Cycle Extern RUN*	Must open and re-apply RUN command
1	Accept Extern RUN	Will accept external RUN command

The Local/Remote function is used to switch the Drive's Sequence and Reference commands from Remote (as defined by the setting of *n002*) to Local (i.e. from the Digital Operator). This function is enabled by programming a Multi-function input terminal (setting *n036* thru *n040*) to "LOC/REM Sel" ("5").

If the Drive is running from a Local RUN command (Digital Operator) (which assumes the Local/Remote Multi-function input is closed to terminal SC), the Drive will stop if the STOP key of the Digital Operator is pressed, as usual.

If the Local/Remote input is then opened, the reference will immediately switch over to the Remote reference, and :

if *n111* = "Cycle Extern RUN" ("0"), the external RUN command must then be removed and re-applied in order for the Drive to run.

if *n111* = "Accept Extern RUN" ("1"), the Drive will run immediately if the external RUN command is still applied.

Note: if *n002* is set to "SEQ=OPR REF=OPR" ("0"), the Local/Remote function will have no effect.

## 5.16 MODBUS CONTROL

The drive can perform serial communication by using a programmable controller (PLC) and MODBUS™ protocol. MODBUS is composed of one master PLC and 1 to 31 (maximum) slave units (GPD 506/P5 drives). In serial communication between the master and slaves, the master always starts transmission and the slaves respond to it.

The master communicates with one slave at a time. Address numbers are assigned to each slave in advance, and the master specifies an address to communicate with. The slave which receives the command from the master executes the function, and then responds to the master.

### A. Communication Specifications

- Interface : RS-232C (standard); RS-485, RS-422 (option - requires communication interface card CM086)
- Synchronization : Asynchronous
- Transmission parameters :
  - Baud rate* — Selectable from 2400, 4800, 9600 BPS (**n105**)
  - Data length* — Fixed to 8 bits
  - Parity* — Parity / no parity, even / odd selectable (**n106**)
  - Stop bit* — Fixed to 1 bit
- Protocol : MODBUS
- Maximum number to units to be connected : 31 units (when RS-485 is used)

### B. Sending/Receiving Data

Data that can be sent and received are run/stop commands, frequency reference, fault reset, drive status, and setting and reading of parameters.

**n002** : Operation Mode Selection (Oper Mode Select)

LED Setting	LCD Setting	Description	
		Sequence	Reference
0	SEQ=OPR REF=OPR	Digital Operator	Digital Operator
1	SEQ=TRM REF=OPR	External Terminals	Digital Operator
2	SEQ=OPR REF=TRM	Digital Operator	External Terminals
3	SEQ=TRM REF=TRM**	External Terminals	External Terminals
4	SEQ=OPR REF=COM	Digital Operator	Serial Communications
5	SEQ=TRM REF=COM	External Terminals	Serial Communications
6	SEQ=COM REF=COM	Serial Communications	Serial Communications
7	SEQ=COM REF=OPR	Serial Communications	Digital Operator
8	SEQ=COM REF=TRM	Serial Communications	External Terminals

Select the run command and frequency reference input method in **n002**. To provide a run command and/or frequency reference by communication, set this parameter to one of the last five settings. Monitoring of run status, parameter setting/reading, fault reset and multi-function input command from the PLC are enabled. The multi-function input command is OR'ed with the command input from control circuit terminals S2-S6.

**5.16 MODBUS CONTROL**

Continued

**n 036** thru **n 040** : Multi-function Inputs  
(Term. S2-S6 Sel)Data COM/Inv Sel (**6**) : Serial Communication /  
Digital Operator

Selects operation by serial communication or by external terminal. If the status of this command input is changed while the drive is running, the selection is ignored until the next time the drive is stopped.

- Open : Run according to the setting of Operation Mode Selection (**n 002**)
- Closed : Run by frequency reference and run command from serial communication

EXAMPLE: **n 002** setting is SEQ=TRM REF=TRM (" 3 ").

- Open : Run by frequency reference from control circuit terminals FV, FI and run command from control circuit terminals S1, S2.
- Closed : Run by frequency reference and run command from serial communication.

**n 103** : Modbus Frequency Resolution  
(MODBUS Fref Unit)

LED Setting	LCD Setting
0*	1 = 0.1 Hz *
1	1 = 0.01 Hz
2	30000 = 100%
3	1 = 0.1 %

The frequency resolution from the PLC and in the frequency reference and output frequency monitor (by communication) are selected with this parameter. The output frequency resolution of the drive is 0.1 Hz. Even if the Modbus resolution is changed to 0.01 Hz in **n 103**, the

value in the hundredths digit of 0.01 Hz of the received frequency reference is rounded off internally. When 30,000/100% in units of 0.1% is selected, the value is also rounded off.

**n 104** : Modbus Slave Address  
(MODBUS Address)Factory setting: **1**

Range: 0 to 31

Each slave drive on the same transmission line must be given a unique address.

**n 105** : Modbus Baud Rate  
(MODBUS Baud Rate)

Selects the baud rate, as indicated by the following table:

LED Setting	LCD Setting (BPS)
0	2400 Baud
1	4800 Baud
2*	9600 Baud*

## 5.16 MODBUS CONTROL

**n 106**: Modbus Parity Selection  
(MODBUS Parity)

Selects the parity, as indicated by the following table:

LED Setting	LCD Setting (BPS)
0*	No Parity *
1	Even Parity
2	Odd Parity

NOTE: To change the values set in **n 104** thru **n 106** and enable the new settings, it is necessary to turn OFF power to the Drive, then turn it ON again.

**n 101**: Modbus Time Out Detection  
(MODBUS Timeout)

LED Setting	LCD Setting
0	Disabled
1*	Enabled*

If time between Modbus messages exceeds 2.0 seconds, the drive will respond according to the setting of **n 102**.

**n 102**: Stop Method on Modbus Communication  
Error (CE) (MODBUS Fault Stop)

If communications error exists, drive will respond according to the following table:

LED Setting	LCD Setting	Description
0	Ramp STOP / Decel 1	Ramp to Stop - Decel 1 (fault)
1*	Coast to STOP *	Coast to Stop (fault)
2	Ramp STOP / Decel 2	Ramp to Stop - Decel 2 (fault)
3	Continue Oper	Continue Operation (alarm)

## 5.16.1 MISCELLANEOUS PROTECTIVE FUNCTIONS

**n110** : Operator Connection Fault Detection  
Selection (Oper Detect Flt)

LED Setting	LCD Setting
0*	Disabled*
1	Enabled

Set this parameter to "Enabled" ("1") only if the drive should shut down immediately if the Digital Operator is disconnected while the drive is running. When set to Disabled ("2") the fault will not occur until after the drive has been stopped.

## 5.17 MOMENTARY POWER LOSS RIDE-THRU

### **n055** : Momentary Power Loss Ride-thru Protection

LED Setting	LCD Setting	Description
0*	Not Provided*	Disabled (Factory setting)
1	2 Seconds Max	Enabled – 2 sec. power loss ride-thru
2	CPU Power Active	Enabled – indefinite power loss ride-thru, provided control power is maintained

The setting of this parameter either enables or disables the ride-thru feature of the drive. If disabled, the unit will stop immediately whenever a power loss occurs. If enabled, the drive will continue to operate during a momentary power loss of up to 80%, but if the loss exceeds the identified time period, the drive will stop.

### **n059** : Power Loss Ride-Thru Deactivation Time (PwrL Ridethru t)

Factory setting: <i>See Table A3-1</i>
Range: 0.0 to 2.0 seconds

If the loss exceeds the length of time identified by **n059**, the drive will stop. The factory setting of this parameter, in 0.1 second increments, is related to the drive's rating.

Note that the RUN command must be maintained throughout the ride-thru period. If **n055** is set to "CPU Power Active" (" 2 "), a " **Uv** Undervoltage " alarm is displayed during power loss, and no fault signal is output at terminals M1 & M2 or MA, MB & MC.



## 5.18 MULTI-FUNCTION ANALOG MONITOR OUTPUT (Term. AM & AC)

### *n052* : Multi-function Analog Output (Terminal AM Sel)

The monitor output provides a 0-10 Vdc signal proportional to either output frequency, output current, output voltage reference, or output power between terminals AM & AC:

LED Setting	LCD Setting	Description
0*	Output Freq *	0-10 VDC proportional to output frequency
1	Output Amps	0-10 VDC proportional to output current
2	Output KWatts	0-10 VDC proportional to output power
3	DC Bus Voltage	0-10 VDC proportional to DC bus voltage

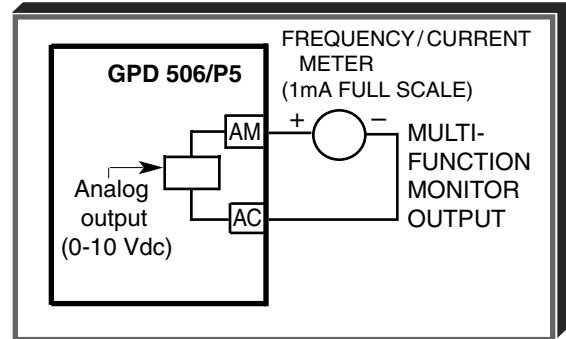

### *n053* : Analog Monitor Gain (Terminal AM Gain)

Factory Setting: **1.00**

Range: 0.01 to 2.00

This constant is used to calibrate, in increments of 0.01, either the frequency, current or volt meter connected to terminals AM & AC.

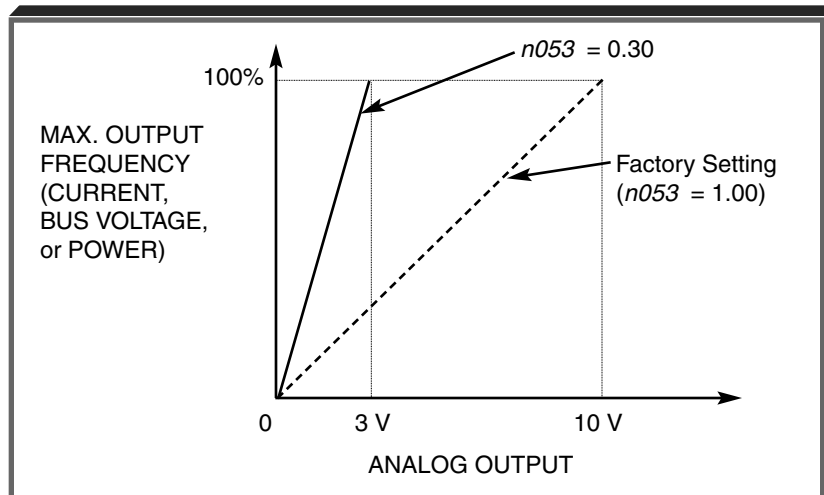

## 5.19 MULTI-FUNCTION INPUT TERMINALS (Term. S2-S6)

**n036** : Terminal S2 Sel  
**n037** : Terminal S3 Sel  
**n038** : Terminal S4 Sel  
**n039** : Terminal S5 Sel  
**n040** : Terminal S6 Sel

Factory Settings:	2-Wire Control	
	LED	LCD
n036	0	Reverse RUN (2W)
n037	2	Ext Fault (NO)
n038	4	Fault Reset
n039	10	Multi-Step Spd 1
n040	11	Multi-Step Spd 2

Factory Settings:	3-Wire Control	
	LED	LCD
n036	1	FWD/REV Cmd (3W)
n037	--	--
n038	4	Fault Reset
n039	10	Multi-Step Spd 1
n040	11	Multi-Step Spd 2

These five parameters select the input signal functions for terminals S2 thru S6, and can be independently set.

Parameter settings are checked whenever power is applied to the drive, or upon exiting Program mode. A parameter set value failure (" **oPE3** MF Input Error") will occur if any of the following conditions are detected among these five parameters:

- (1) Two or more of the parameters contain the same value.
- (2) Both Speed Search functions "Sel Srch (MAXFRQ)" ("17") and "Spd Srch (SETFRQ)" ("8") have been selected.
- (3) Both the "Ref Sample/Hold" ("24") and "Up/Down Control" ("29") functions have been selected.

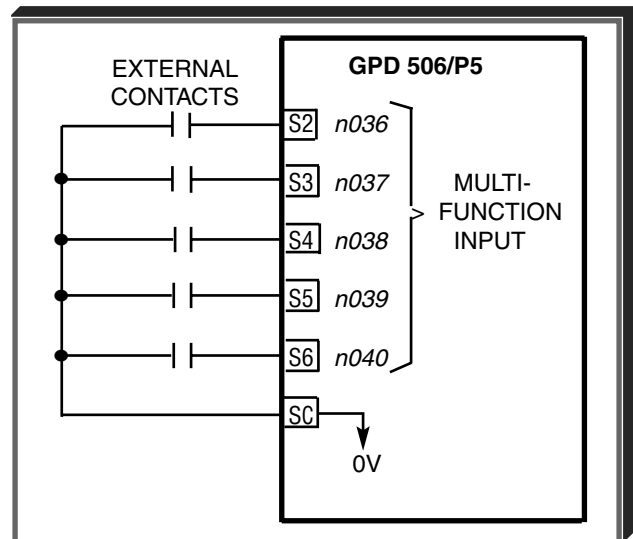

Table 5-2 lists the possible data setting values for these parameters, with the function and a brief description for each one.

For a few of the data settings, a more detailed description is given on the following pages; for others, the description is given in other PROGRAMMABLE FEATURES paragraphs.

**5.19 MULTI-FUNCTION INPUT TERMINALS (Term. S2-S6)** Continued

**Table 5-2. n036 thru n040 Data Settings**

LED SETTING	LCD SETTING	FUNCTION	DESCRIPTION **
0	Reverse RUN (2W)	Reverse Run/Stop command (for 2-wire control)	MUST BE SET ONLY IN <b>n036</b> . Redefines terminals: S1 = Run/Stop Forward; S2 = Run/Stop Reverse
1	FWD/REV Cmd (3W)	FWD/REV selection (for 3-wire control)	MUST BE SET ONLY IN <b>n036</b> . Redefines terminals: S1 = Run; S2 = Stop; S3 = FWD/REV select
2	Ext Fault (NO)	External fault (N.O. contact input)	Drive trips; Digital Operator displays " <b>EFX</b> ", where X is 2-6, corresponding to the terminal S2-S6, which is receiving the fault input signal
3	Ext Fault (NC)	External fault (N.C. contact input)	
4	Fault Reset	Fault Reset	Resets fault, only if RUN command is not present
5	LOC/REM Sel	Remote/Local selection	Open = Operates according to setting of <b>n002</b> Closed = Operates from keys of the Digital Operator <b>See paragraph 5.19A</b>
6	COM/INV Sel	GPD Drive operation & reference/serial communication selection	Open = Operates according to setting of <b>n002</b> Closed = Operates from serial communication <b>See paragraph 5.16</b>
7	STOP Cmd/Dec 2 NO	Quick Stop (N.O. Contact Input)	Open = Stop according to setting of <b>n004</b> Closed = Ramp to stop by Decel Time 2 ( <b>n021</b> )
8	STOP Cmd/Dec 2 NC	Quick Stop (N.C. contact input)	Open = Ramp to stop by Decel Time 2 ( <b>n021</b> ) Closed = Stop according to setting of <b>n004</b>
9	Master FREF Sel	Auto/Manual frequency reference selection	If <b>n043</b> = "FV=MSTR FI=Aux" ("0") Open = Frequency reference from terminal FV Closed = Frequency reference from terminal FI If <b>n043</b> = "FV=Aux FI=MSTR" ("1") Open = Frequency reference from terminal FI Closed = Frequency reference from terminal FV
10	Multi-Step Spd 1	Multi-step frequency ref. select 1	<b>See paragraph 5.19B</b>
11	Multi-Step Spd 2	Multi-step frequency ref. select 2	
12	Multi-Step Spd 3	Multi-step frequency ref. select 3	
13	JOG Command	Jog selection	Closed = Jog selected <b>See paragraph 5.15</b>

**5.19 MULTI-FUNCTION INPUT TERMINALS (Term. S2-S6)** Continued

**Table 5-2. n036 thru n040 Data Settings - Continued**

LED SETTING	LCD SETTING	FUNCTION	DESCRIPTION **
14	ACC/DEC Switch	Accel/decel time selection	Open = Accel/decel by <b>n018 / n019</b> Closed = Accel/decel by <b>n020 / n021</b> <b>See paragraph 5.2</b>
15	Ext Baseblk (NO)	External base block (N.O. contact input)	Closed = Shuts off drive output (frequency command is held)
16	Ext Baseblk (NC)	External base block (N.C. contact input)	<b>See paragraphs 5.19C, 5.19D</b>
17	Spd Srch (MAXFRQ)	Speed Search 1	Closed * = Speed Search operation from maximum frequency <b>See paragraph 5.19E</b>
18	Spd Srch (SETRQ)	Speed Search 2	Closed * = Speed Search operation from set frequency <b>See paragraph 5.19E</b>
19	Param Lockout	Programming enable	Open = Programming from Digital Operator or serial communication is enabled Closed = All programming is disabled
20	PID I Reset	PID integral value reset	Closed = Value of I ( <b>n087</b> ) is reset to " 0 " <b>See paragraph 5.22I</b>
21	PID Disable	PID control disable	Closed = PID control is disabled – setpoint becomes frequency reference <b>See paragraph 5.22I</b>
22	Timer Start Cmd	Timer function	<b>See paragraph 5.19F</b>
23	oH3 Input	External overheat	Closed = <b>oH3</b> blinks on the Digital Operator, and operation continues (minor fault)
24	Ref Sample Hold	Analog reference sample/hold	Open = Hold frequency reference Closed = Sample frequency reference <b>See paragraph 5.19G</b>
25	KEB Cmd (NO)	Inertia ride-thru command (N.O. contact input)	Closed = Inertia ride-thru is enabled
26	KEB Cmd (NC)	Inertia ride-thru command (N.C. contact input)	Closed = Inertia ride-thru is disabled
27	Hold Command	Accel/Decel Hold	<b>See paragraph 5.19 H</b>
28	PID Polarity Sel	PID Changeover	<b>See paragraph 5.19 I</b>
29	Up/Down Control	Up/Down function	<b>See paragraph 5.19 J</b> (can only be set in <b>n040</b> )

\*\* All contact closures must be maintained, except for speed search, which may be momentary (see paragraph 5.19E).

## 5.19 MULTI-FUNCTION INPUT TERMINALS (Term. S2-S6)

Continued

### A. Local/Remote Sel ( 5 ) : Remote/Local Selection

Set parameter **n002** to "SEQ=TRM REF=TRM" (" 3 ") to select external inputs as the source for frequency reference and operation commands. The use of a Remote/Local command input allows switching between the Digital Operator control and the external terminal input signals, without the need to re-program **n002**. If the status of the Remote/Local command input is changed while the drive is running, the Remote/Local operation selection is not completed until the next time the drive is stopped.

Closed = Controlled locally (Digital Operator)

Open = Controlled remotely (external terminal inputs, for Start/Stop and frequency reference)

- B. Multi-Step Spd 1 (10): Multi-step Frequency Ref. Select 1**  
**Multi-Step Spd 2 (11): Multi-step Frequency Ref. Select 2**  
**Multi-Step Spd 3 (12): Multi-step Frequency Ref. Select 3**

**n024** thru **n030**: Frequency Reference 1-6  
and Jog Reference

Factory settings: **n030 = 6.0**  
all others = **0.0**

Range (ea): 0.0 to 9999

In order to use multi-step frequency presets, parameters **n037, n038, n039 & n040** must be programmed accordingly for 2-Wire or 3-Wire control. (Parameter **n002** must be set for frequency reference from Digital Operator.)

To use the maximum of 7 preset frequencies, **n037** must be set to "Multi-step Spd Sel 1" (" 10 "), **n038** must be set to "Multi-step Spd Sel 2" (" 11 "), and **n039** must be set to "Multi-step Spd Sel 3" (" 12 "), and **n040** must be set to "Jog Command" (" 13 ")

Note that the remote frequency reference (terminal FV) can be substituted for Freq. Ref. 1 by selecting the Remote mode, either with the **LOCAL/REMOTE** key on the Digital Operator, or programming one of the Multi-function inputs for "Local/Remote Sel" ("5").

See next page for timing chart of multi-step speed operation.

Multi-step (7 preset frequencies) in 2-Wire control

PARAMETER and NAME	EXTERNAL TERMINAL			
	S6	S5	S4	S3
n024 Frequency Ref 1	0	0	0	0
n025 Frequency Ref 2	0	0	0	1
n026 Frequency Ref 3	0	0	1	0
n027 Frequency Ref 4	0	0	1	1
n028 Frequency Ref 5	0	1	0	0
n029 Frequency Ref 6	0	1	0	1
n030 Jog Reference	1	X	X	X

1 = Closed ( ref terminal SC )  
0 = Open ( ref terminal SC )  
X = Doesn't matter

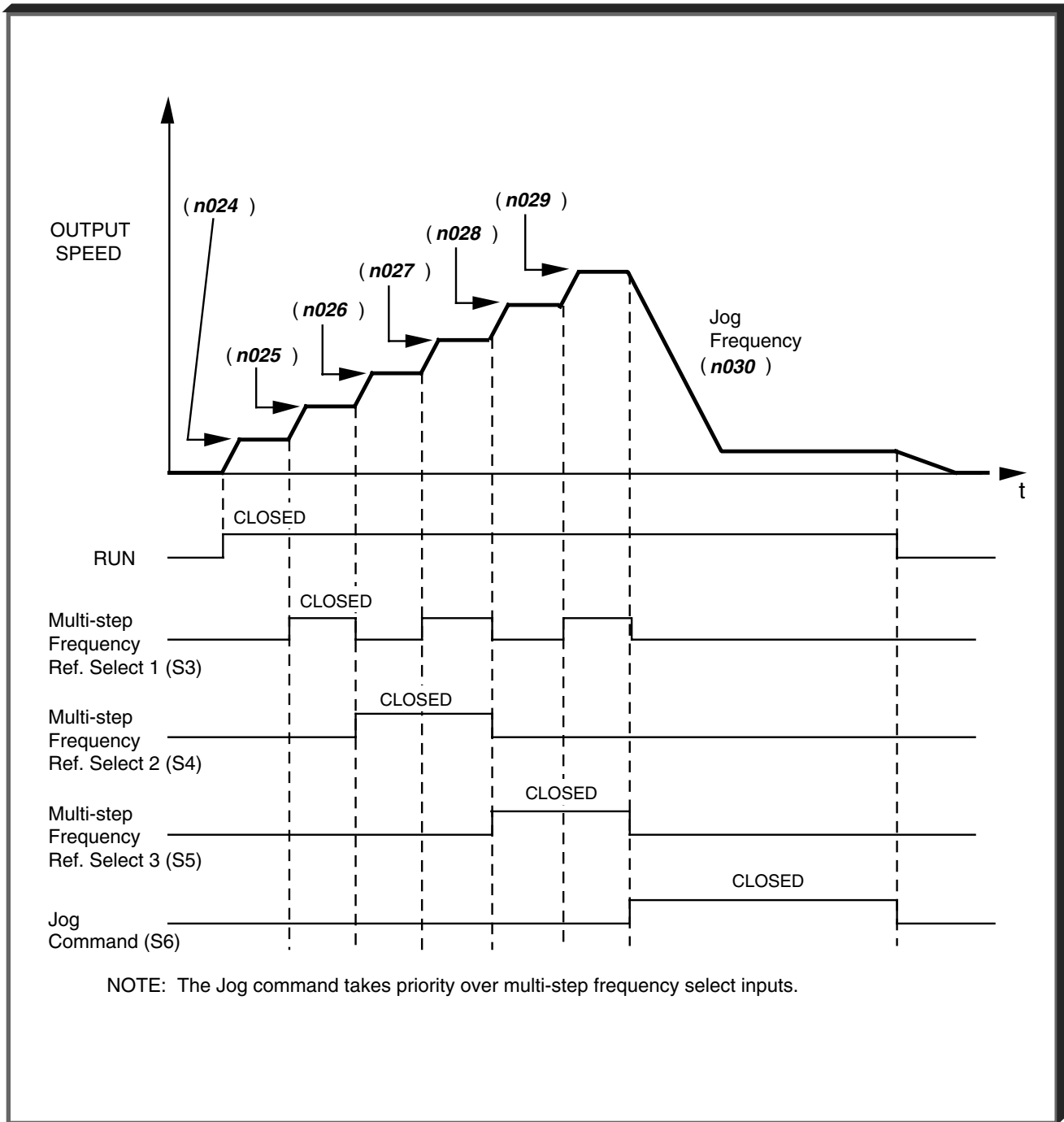

**Typical Multi-step Speed Operation**

## 5.19 MULTI-FUNCTION INPUT TERMINALS (Term. S2-S6)

Continued

### C. Ext Baseblk (NO) (15): External Base Block by N.O. Contact

- When either the Forward Run command or Reverse Run command is present, and the external Base Block command is applied (i.e. contact closed), coast stop is accomplished (after a 20 msec delay), while the frequency command is maintained. When the Base Block command is removed, the drive will recover in a manner similar to that of Speed Search operation.

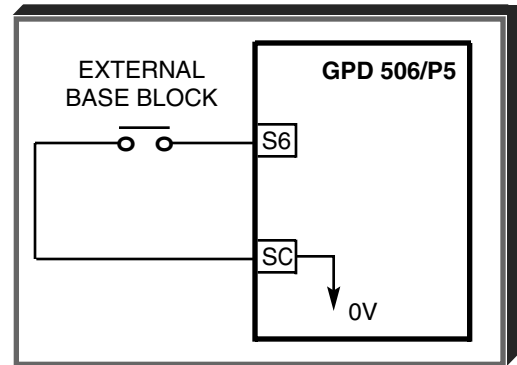

- When both the Forward Run command and Reverse Run command are open, and the external Base Block command is applied (i.e. contact closed), coast stop is accomplished and after a 20 msec delay the frequency command is changed to 0Hz. When the Base Block command is removed, the drive will remain in stopped condition until Forward Run command or Reverse Run command is again applied.
- When external Base Block command is active, a blinking " **bb** Base Block" will be displayed on the Digital Operator.

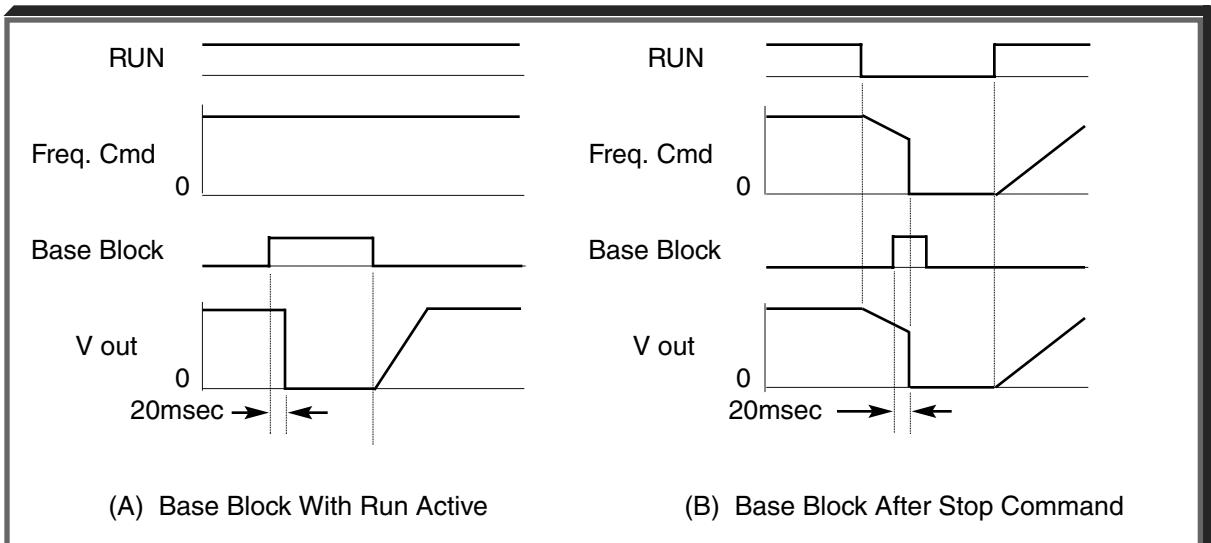

### D. Ext Basedblk (NC) (16): External Base Block by N.C. Contact

Base block operation is the same as described above, except that the Base Block contact must be *open* to be recognized.

## 5.19 MULTI-FUNCTION INPUT TERMINALS (Term. S2-S6)

Continued

- E. Spd Srch (MAX FRQ) (17): Speed Search From Max Frequency  
Spd Srch (SET FRQ) (18) : Speed Search From Set Frequency

A multi-function input terminal is utilized to activate speed search. When the external speed search command is closed, the base is blocked for the min. base block time, **n057**, then the speed search is made. The operation depends on the set value.

### IMPORTANT

Spd Srch (MAX FRQ) (17) and "Spd Srch (SET FRQ)" ("**18**") CANNOT be selected in combination.

- When "Spd Srch (MAX FRQ)" ("**17**") is set, the speed search begins with the maximum frequency.
- When "Spd Srch (SET FRQ)" ("**18**") is set, the speed search begins with the frequency command that has been set after the search command was received.

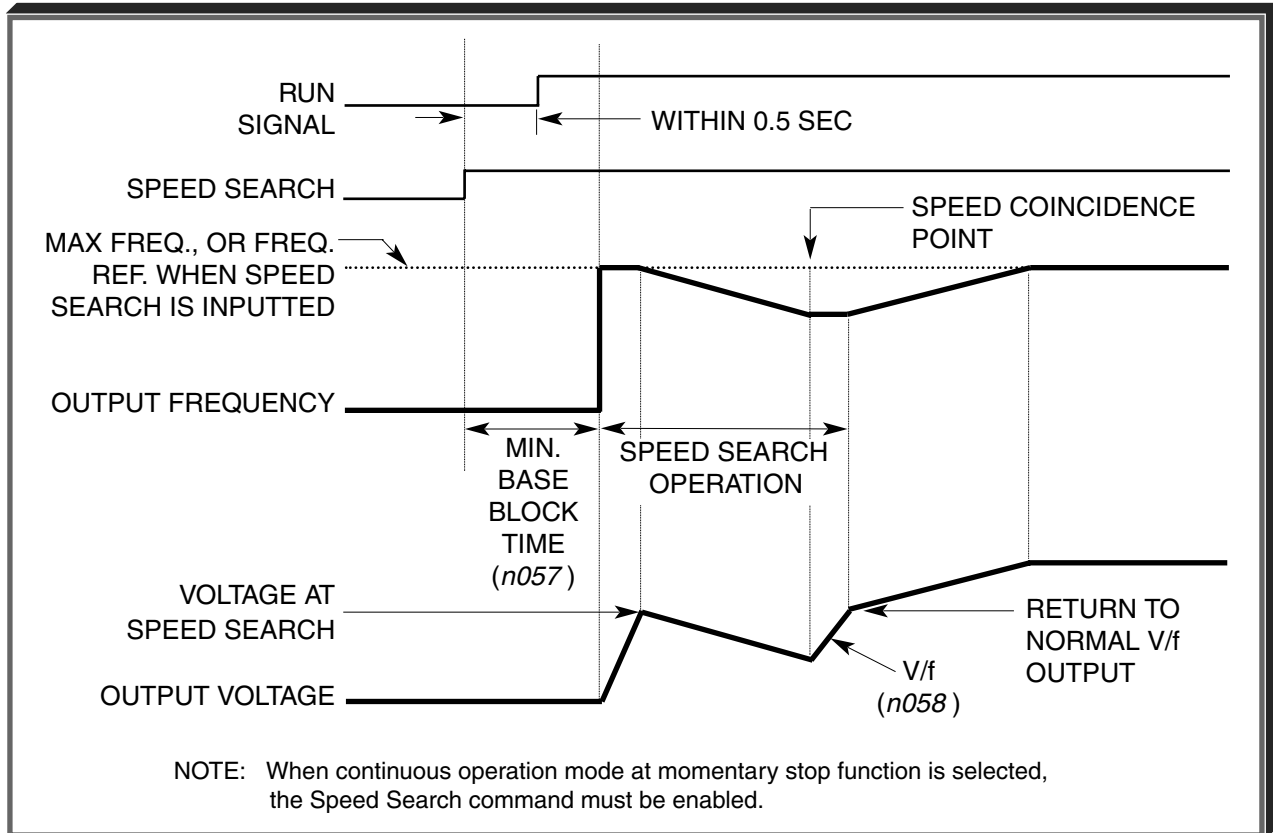

### Speed Search Operation Timing

**n056** : Speed Search Deactivation Current Level  
(SpdSrch Current)

Factory setting: <b>110</b> %
Range: 0 to 200 %

After power recovery, if the drive output current is larger than the set value of **n056**, speed search is started, using a decel rate of 2.0 sec. When drive output current is lower than the set value of **n056**, speed search is complete and acceleration or deceleration is continued at the normal rate (**n018 - n021**) to set frequency.



## 5.19 MULTI-FUNCTION INPUT TERMINALS (Term. S2-S6)

Continued

**n057** : Minimum Baseblock Time  
(Min Baseblock t)

Factory setting: See Table A3-1

Range: 0.0 to 25.5 sec.

When a momentary power loss is detected, the drive output transistors are disabled for a period of time determined by the setting of **n057**. The **n057** setting should represent the time required for the motor residual voltage to go to zero.

When the momentary power loss time exceeds the minimum base block time, the speed search operation is started immediately after power recovery.

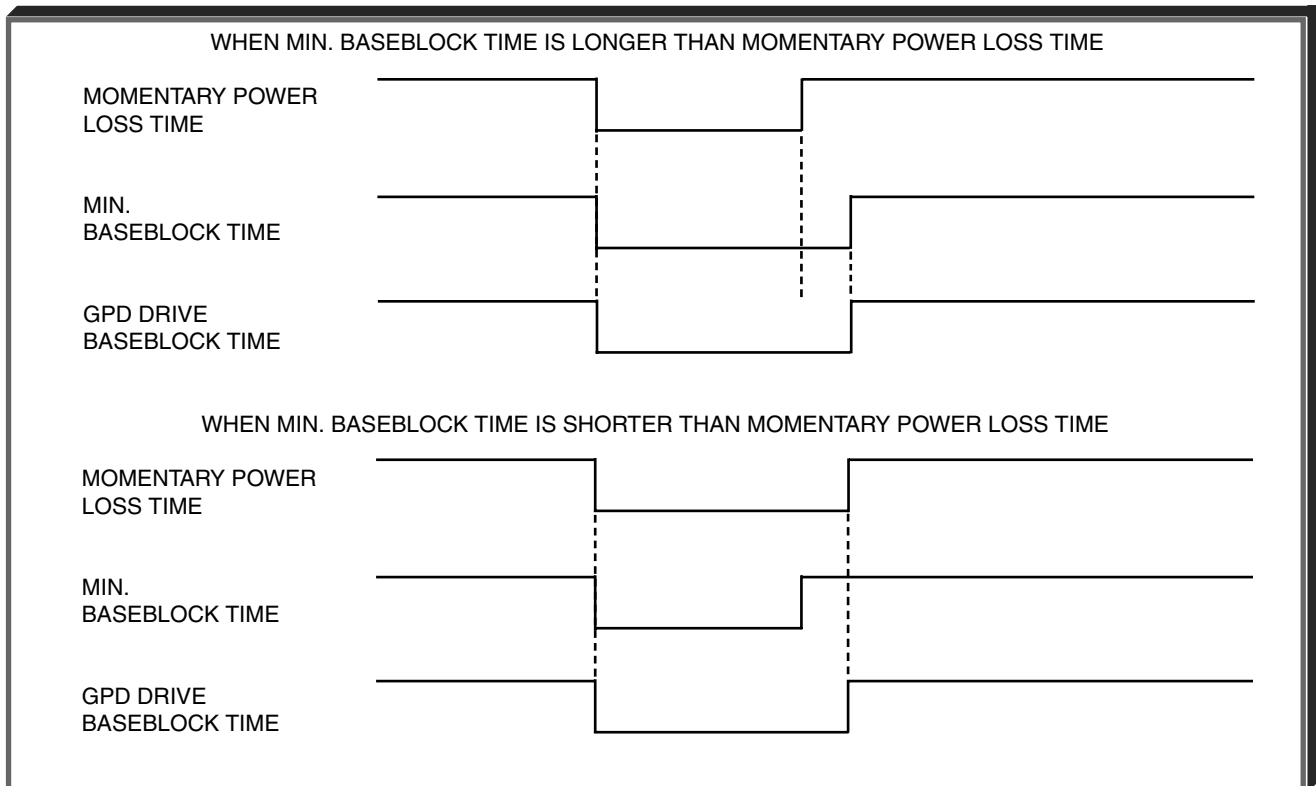

**n058** : V/f During Speed Search  
(SpdSrch V/F)

Factory setting: See Table A3-1

Range: 0 to 100 %

To prevent a fault such as OC from occurring during the speed search operation, V/f must be set to a value lower than that required during normal operation.

$$\text{V/f during speed search} = \text{V/f at normal operation} \times \mathbf{n058}$$

**5.19 MULTI-FUNCTION INPUT TERMINALS (Term. S2-S6)**

Continued

**F. Timer Start Cmd (22): Timer Function**

**n041** or **n042** : Multi-function Output Terminals

Timer Output **1 1** : Timer Function

(Terminal MA Sel) or (Terminal M1 Sel)

**n080** : On-Delay Timer

Factory setting: **0.0** sec.

Range: 0.0 to 25.5 sec.

**n081** : Off-Delay Timer

Factory setting: **0.0** sec.

Range: 0.0 to 25.5 sec.

When the timer function input is “closed” for longer than On-delay Timer (**n080**), the timer function output closes.

When the timer input is “open” for longer than Off-delay Timer (**n081**), the timer function output opens.

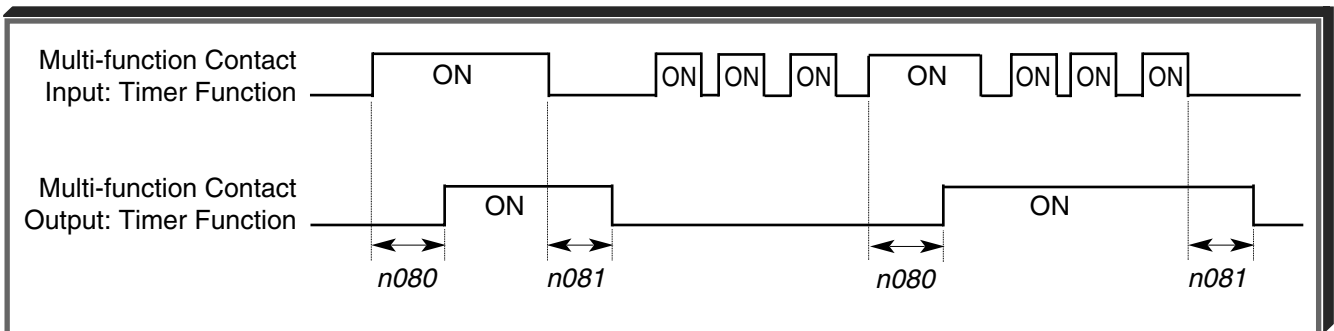

As can be seen, the timer function must be programmed as both a multi-function input **and** an output to be effective.

## 5.19 MULTI-FUNCTION INPUT TERMINALS (Term. S2-S6)

Continued

### G. Ref Sample Hold (24) : Sample/Hold Command

This function applies only to an analog voltage or current input used as a frequency reference at terminals FV or FI.

If the Sample/Hold command is present (contact is closed) for more than 0.1 sec., the frequency reference will follow (sample) the analog signal, e.g. if 5V corresponds to 50% frequency, a 5V analog signal will produce 50% frequency reference if the Sample/Hold command is present.

If the Sample/Hold command is removed (contact is opened) while the Drive is still in Run condition, the frequency reference is held at the level it was at the time the Sample/Hold command was removed, e.g. the frequency reference would remain at 50%, even though the analog signal increased to 8V.

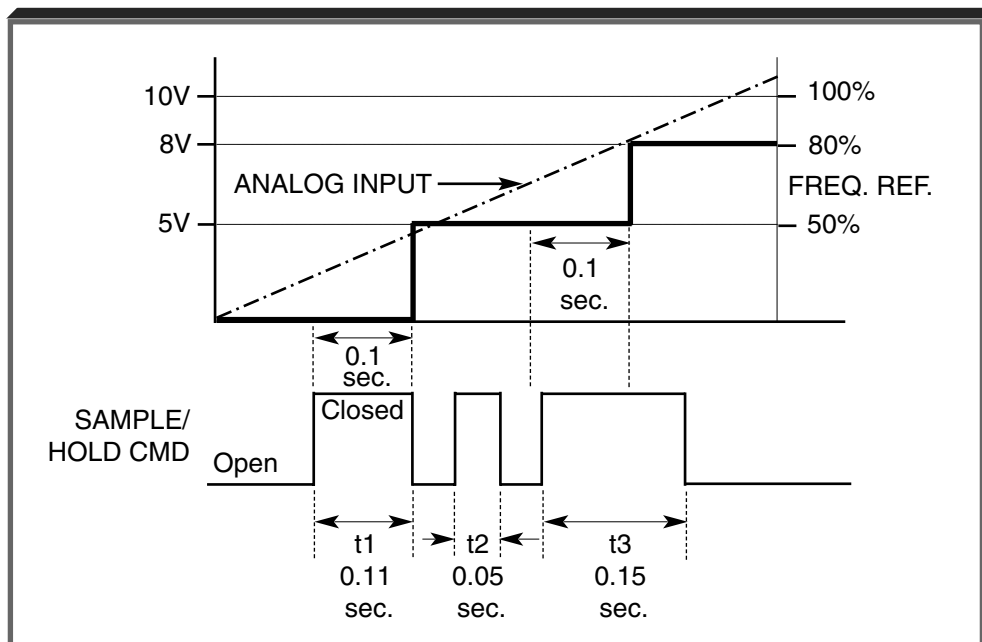

**Sample/Hold Function Timing**

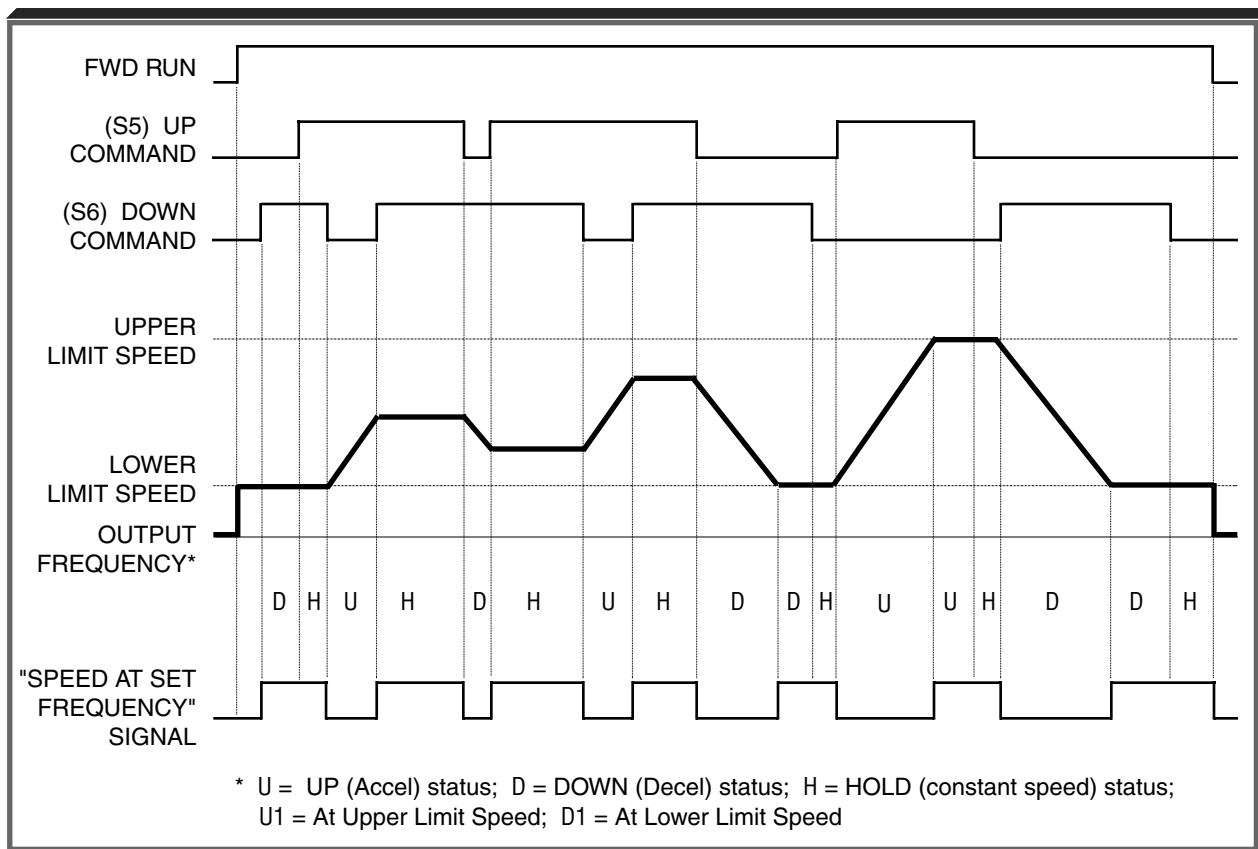

***Up/Down Frequency Setting Timing***

**H. Hold Command (27): Accel/Decel Hold**

By programming data "Hold Command" (" 27 ") into one of the multifunction input parameters ( *n036* thru *n040* ), one of the multi-function input terminals (S2 thru S6) becomes a HOLD command input. As long as the HOLD command is present, accel and decel are in a prohibit state, and the output speed is held at the level it was at the time the HOLD command was input. When the HOLD command is removed while the system is still in Run condition, accel or decel will again become active to allow output to reach set speed. If Stop is initiated while the HOLD command is present, the prohibit state is cancelled and the system enters stop operation.

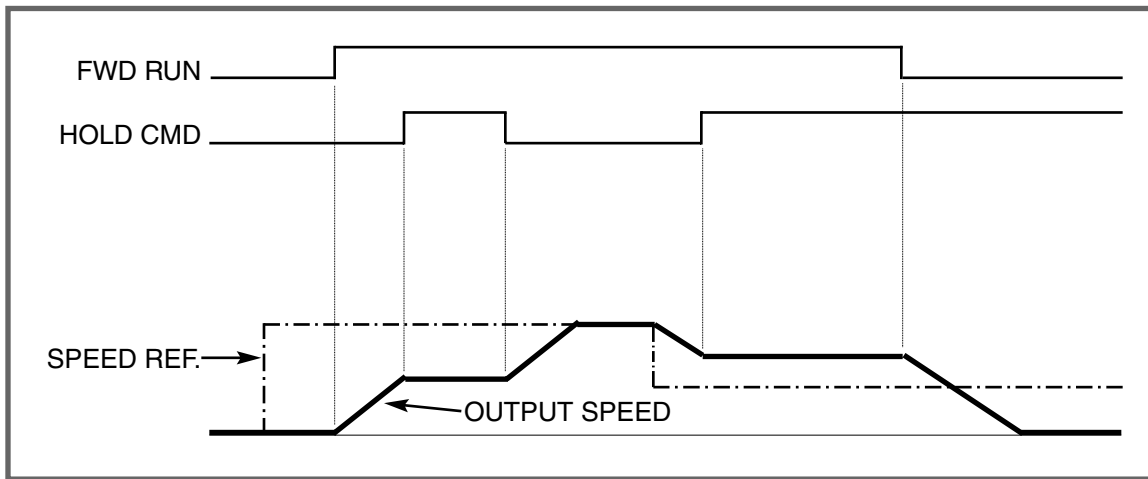

**HOLD Function Timing**

**I. PID Polarity Sel ( 28 ) : PID Changeover**

Programming data "PID Polarity Sel" (" 28 ") for *n040* allows the PID input characteristic changeover to function as follows:

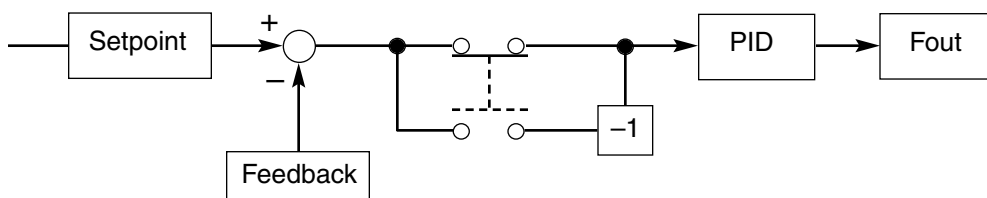

Multi-function input: Open = As usual  
 Closed = Polarity of Deviation is changed over

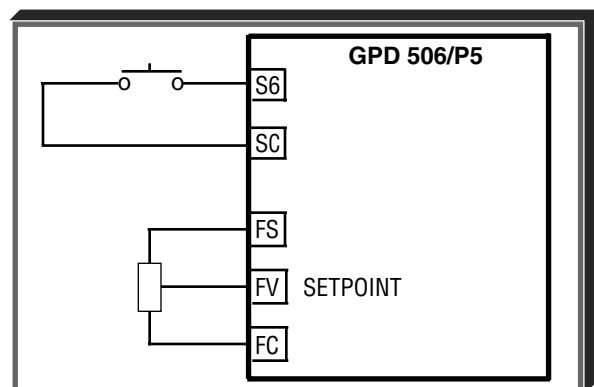

## 5.19 MULTI-FUNCTION INPUT TERMINALS (Term. S2-S6)

Continued

### J. Up/Down Control ( 29 ): Up/Down Function

Programming data "Up/Down Control" (" 29 ") for **n040** (multi-function input terminal) allows the inputs to be used for Up/Down frequency setting.

#### NOTES:

1. Parameter **n039** will display "--" when **n040** is set to "Up/Down Control" (" 29 ").
2. Jog has priority over Up/Down.
3. Up/Down has priority over Multi-step Frequency inputs.
4. Up/Down is ineffective when operation is from the Digital Operator.
5. Upper limit speed is set by the formula:  

$$n011 (F_{max}) \times \frac{n031 (Freq. Ref. Upper Limit)}{100}$$
6. Lower limit speed is either the reference from external terminals FV or FI, or from **n032**, Frequency Reference Lower Limit, whichever is higher.
7. Upon a Forward (or Reverse) Run command, the drive will operate at the lower limit speed, until an UP command is given.

#### EXAMPLE:

**n040** "Up/Down Control" ( 29 ):  
Up/Down function

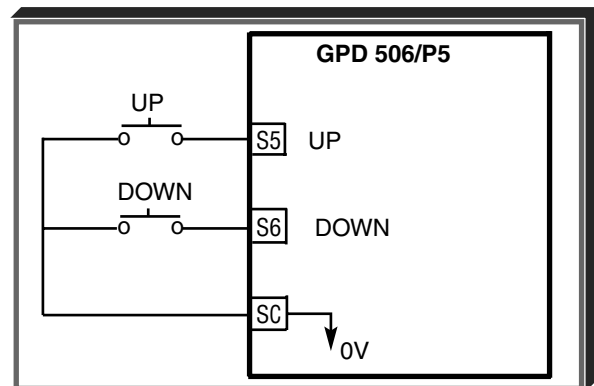

INPUT SIGNAL		FUNCTION
Term. S5 UP	Term. S6 DOWN	
Open	Open	HOLD
Closed	Open	UP (Frequency command approaches frequency command upper limit)
Open	Closed	DOWN (Frequency command approaches minimum output frequency or frequency command lower limit, whichever is larger)
Closed	Closed	HOLD

## 5.20 MULTI-FUNCTION OUTPUT TERMINALS (Term. MA, MB & MC; M1 & M2)

**n041** : Contact Output (external terminals MA, MB & MC)  
(Terminal MA Sel)

**n042** : Contact Output (external terminals M1 & M2)  
(Terminal M1 Sel)

A Form-C contact, or an N.O. contact, can be programmed to change states during any of the conditions indicated in Table 5-3.

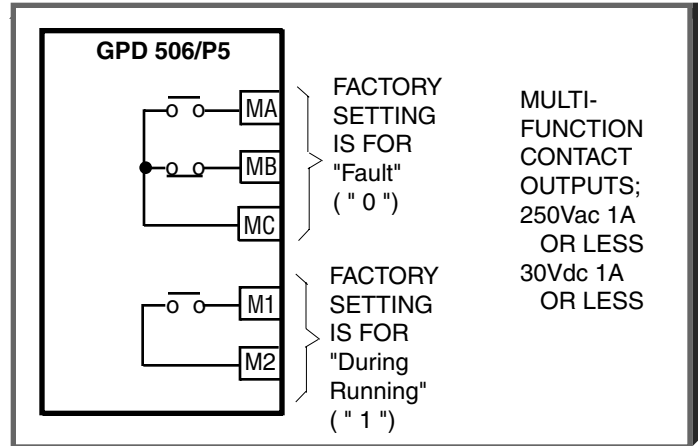

**Table 5-3. Multi-function Output Terminals**

LED SETTING	LCD SETTING	CONDITION	SIGNAL LEVEL
<b>0*</b>	<b>Fault*</b>	Fault	Closed = Drive fault has occurred (except CPF0, CPF1)
<b>1*</b>	<b>During Running*</b>	During operation	Closed = Drive is operating
<b>2</b>	At Speed	Speed at set frequency	Closed = Frequency Reference = output frequency <b>See description on next page</b>
<b>3</b>	At Desired Speed	Speed coincidence	Closed = Speed at set frequency and output frequency = <b>n075</b> <b>See description on next page</b>
<b>4</b>	Freq Detection 1	Frequency detection - low	Closed = Output frequency $\leq$ <b>n075</b> . <b>See description on next page</b>
<b>5</b>	Freq Detection 2	Frequency detection - high	Closed = Output frequency $\geq$ <b>n075</b> . <b>See description on next page</b>
<b>6</b>	Overtrq Det (NO)	Overtorque / Undertorque detection (N.O. contact)	Closed = Overtorque / Undertorque detected
<b>7</b>	Overtrq Det (NC)	Overtorque / Undertorque detection (N.C. contact)	Open = Overtorque / Undertorque detected
<b>8</b>	Base Blocked	During coast to stop	Closed = Drive output base block is active; motor is coasting
<b>9</b>	Operation Mode	Frequency or Run reference mode	Open = Frequency or Run Command by ext. input; Closed = Frequency or Run Command by Digital Operator
<b>10</b>	Ready	Operation ready	Closed = Drive is ready for operation (not faulted)
<b>11</b>	Timer Output	Timer function	<b>See paragraph 5.19F</b>
<b>12</b>	Auto-Restarting	Auto-restart	Closed = During auto-restart operation
<b>13</b>	OL Pre-Alarm	OL warning	Closed = 150% current for 48 sec. (OL1) or 80% time (OL2)
<b>14</b>	Freq Ref Loss	Frequency reference missing	Closed = Frequency reference is missing. <b>See paragraph 5.13</b>
<b>15</b>	Set by Com Cntl	Serial communication	Closed = Command from serial communication
<b>16</b>	PID Fdbk Loss	PID feedback loss	Closed = Feedback value < detection level ( <b>n091</b> ) for longer than detection delay time ( <b>n092</b> )
<b>17</b>	OH1 Alarm	OH1 warning	Closed = Heatsink temperature $\geq$ 90°C (194°F) (if <b>n035</b> = 3)

## 5.20 MULTI-FUNCTION OUTPUT TERMINALS

Continued

**n075** : Speed Coincidence Frequency / Frequency  
Detection Level  
(Freq Det Level)

Factory setting: <b>0.0</b> Hz
Range: 0.0 to 400.0 Hz

Speed coincidence is used to control an output contact at terminals MA or MB (with respect to terminal MC), or terminals M1 & M2, when selected by **n041** and **n042**.

**n041** or **n042** : Multi-Fuction Output Terminals  
(Terminal MA Sel) or (Terminal M1 Sel)

The output contact will close, dependent upon the data programmed into **n041** or **n042**. See the appropriate figure below for operation.

**A. Speed at Set Frequency**  
(setting: **n041** or **n042** =  
"At Speed" (" 2 "))

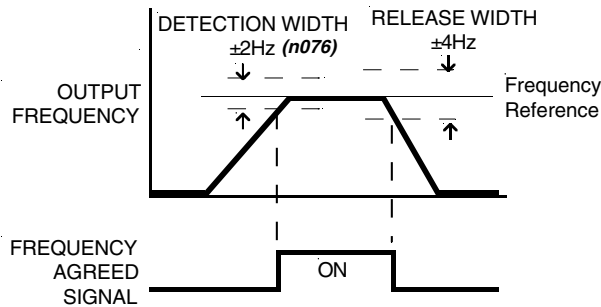

**B. Speed Coincidence**  
(setting: **n041** or **n042** =  
"At Desired Speed" (" 3 "))

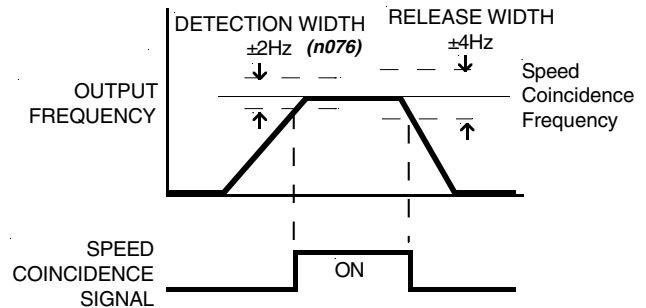

**C. Frequency Detection – Low**  
(setting: **n041** or **n042** =  
"Freq Detection 1) (" 4 "))

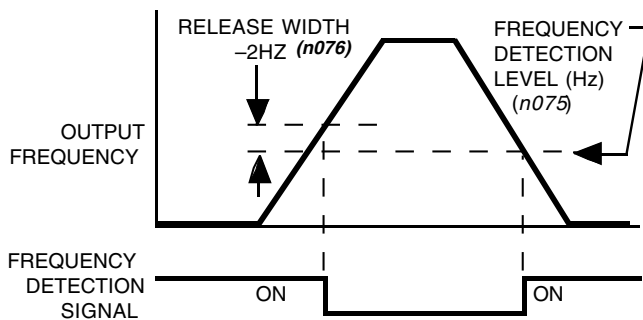

**D. Frequency Detection – High**  
(setting: **n041** or **n042** =  
"Freq Detection 2) (" 5 "))

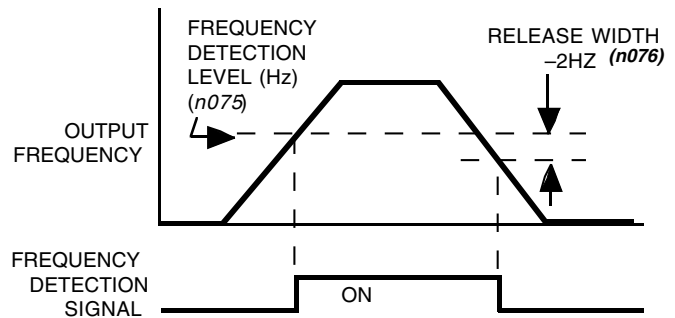

**n076** : Frequency Agreed Detection Width  
(Freq Det Width)

Factory Setting: <b>2.0</b> Hz
Range: 0.0 to 25.50 Hz

This Detection Width setting is used to establish the frequency level at which the output contact activates, when **n041** or **n042** is set to "At Speed" (" 2 ") or "At Desired Speed" (" 3 ").



## 5.21 OVERTORQUE / UNDERTORQUE DETECTION

Overtorque detection is used to compare drive rated output current with the overtorque detection level. When the output current is equal to or greater than the defined level, an overtorque condition exists. This will be indicated as an "**oL3 Overload 3**" fault on the Digital Operator. This feature can be selected to operate over a wide range of conditions.

**A. n077 :** Overtorque / Undertorque Detection  
(Torq Det Sel)

Factory setting: **0**

This constant determines whether the overtorque detection function of the drive is enabled, under what conditions it will detect for overtorque, and what operation it will perform after detecting an overtorque.

LED Setting	LCD Setting	Overtorque / Undertorque Disabled	Operation After Detection	Detection Condition
<b>0*</b>	<b>Disabled*</b>	Disabled	—	—
1	OT/SpdAgree/Alm	Overtorque	Continues	Only at set frequency
2	OT/RUN/Alm	Overtorque	Continues	At all times except during stopping or DC injection braking
3	OT/SpdAgree/Flt	Overtorque	Coast to stop	Only at set frequency
4	OT/RUN/Flt	Overtorque	Coast to stop	At all times except during stopping or DC injection braking
5	UT/SpdAgree/Alm	Undertorque	Continues	Only at set frequency
6	UT/RUN/Alm	Undertorque	Continues	At all times except during stopping or DC injection braking
7	UT/SpdAgree/Flt	Undertorque	Coast to stop	Only at set frequency
8	UT/RUN/Flt	Undertorque	Coast to stop	At all times except during stopping or DC injection braking

- For overtorque detection during accel or decel, set to "OT/RUN Alm" (" 2 ") or "OT/RUN/Flt" (" 4 ").
- For continuous operation after overtorque detection, set to "OT/Spd Agree/Alm" (" 1 ") or "OT/RUN/Alm" (" 2 "). During detection, the Digital Operator displays and "**oL3 Overload 3**" alarm (blinking).
- To stop the drive at an overtorque detection fault, set to "OT/Spd Agree/Flt" (" 3 ") or "OT/RUN/Flt" (" 4 "). At detection, the Digital Operator displays an "**oL3 Overload 3**" fault.
- To output an overtorque detection signal, set output terminal function selection (**n41** or **n42**) to "OverTrq Det (NO)" (" 6 ") or "OverTrq Det (NC)" (" 7 ").

**B. n078 :** Overtorque / Undertorque Detection Level  
(Torq Det Level)

Factory setting: **160 %**

Range: 30 to 200 %

This is the reference point for determining that an overtorque condition exists. Set as a percent of drive rated current (see Appendix 2).

**C. n079 :** Overtorque / Undertorque Detection Time  
(Torq Det Time)

Factory setting: **0.1 sec.**

Range: 0.0 to 10.0 seconds

Determines how long an overtorque condition must exist before another event will occur, e.g. coast to stop, multi-function output change of state, or "**oL3 Overload 3**" warning or fault display.

## 5.21 OVERTORQUE / UNDERTORQUE DETECTION

Continued

- D. **n041** : Multi-function Output 1 – Contact  
(Terminal MA Sel)
- n042** : Multi-function Output 2 – Contact  
(Terminal M1 Sel)

OverTrq Det (NO) ( 6 ) or OverTrq  
Det (NC) ( 7 ) : Overtorque  
/ Undertorque Detection

A Form-C contact, or an N.O. contact, can be programmed to change states during an overtorque detection condition.

### EXAMPLE OF OVERTORQUE DETECTION

**n077** setting: "OT/Spd/Flt" ( 3 ) — Overtorque enabled, only at set frequency, coast to stop

**n042** setting: "OverTrqDet1" ( 6 ) — Output contact programmed for overtorque detection

**n078** setting: **110%** — Level at which overtorque is sensed

**n079** setting: **1.0 s** — Time delay before overtorque event occurs

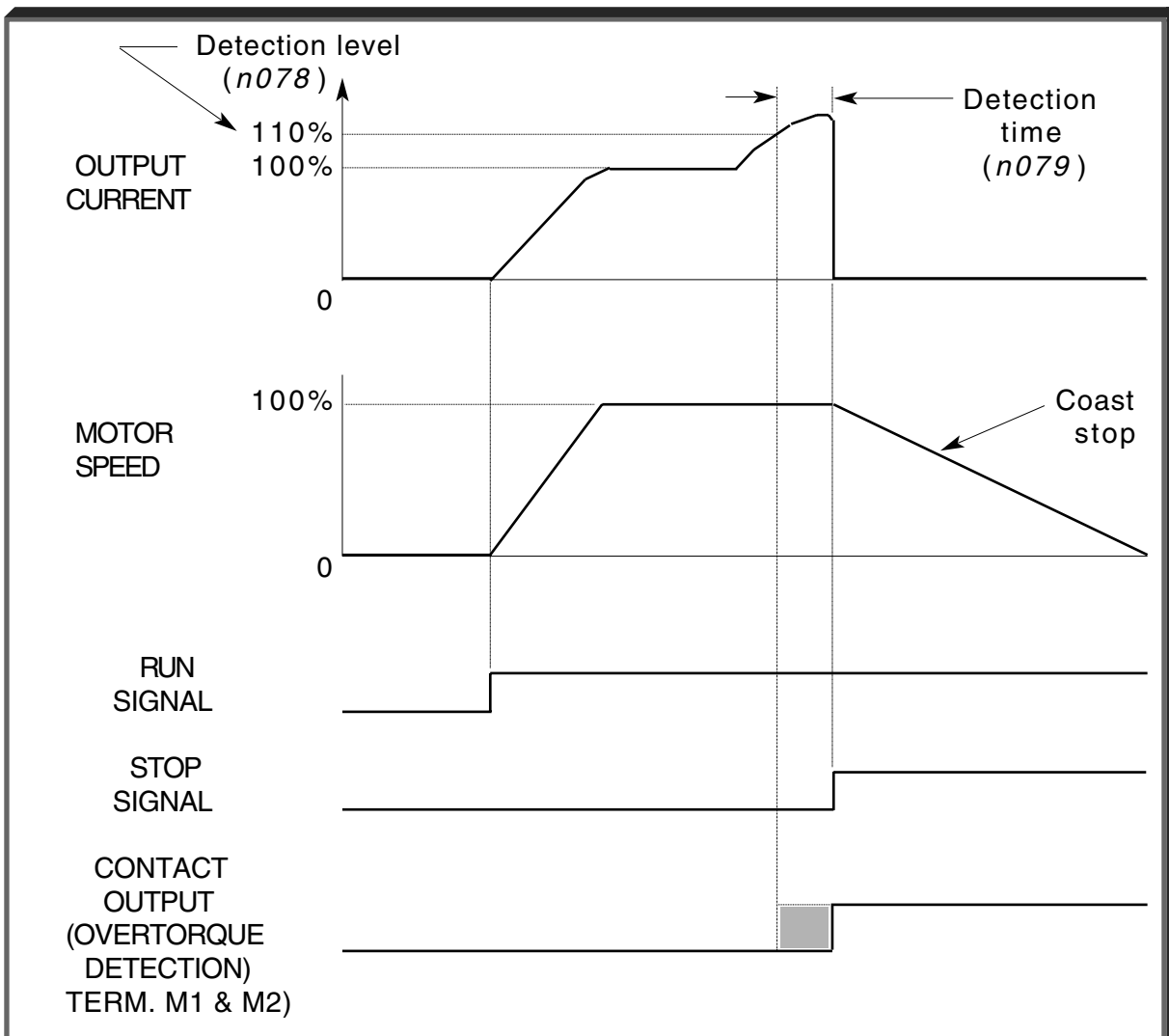

*Overtorque Detection Timing Diagram*

## 5.22 PID CONTROL

The Proportional, Integral and Derivative control function provides closed-loop control, or regulation, of a system process variable (pressure, temperature, etc.). This regulation is accomplished by comparing a feedback signal to a setpoint reference, which results in an error signal. The PID control algorithm then performs calculations, based upon the PID parameter settings (*n084* thru *n092*), on this error signal. The result of the PID algorithm is then used as the new speed reference.

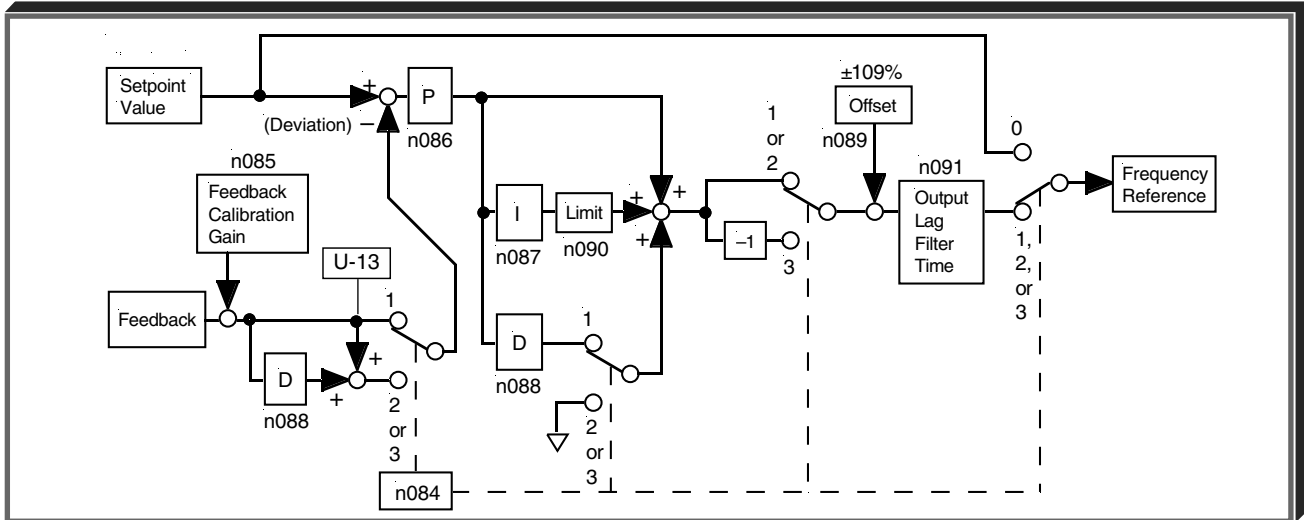

### A. *n084* : PID Selection (PID Mode)

Using this parameter, PID control can be enabled, feed forward function can be activated, or the PID Feedback can be inverted.

LED Setting	LCD Setting	Description
0 *	Disabled*	PID disabled
1	Enabled D=Fdbk	PID enabled (Deviation is D-controlled)
2	Enabled D=Fwd	PID with feed forward (Feedback value is D-controlled)
3	Enabled Rev Fdbk	Inverted PID Feedback signal

## 5.22 PID CONTROL

Continued

### B. Setpoint Reference Selection

**n002** : Operation Mode Selection  
(Oper Mode Sel)

**n043** : Analog Input Selection  
(AnalogInput Sel)

**n024** thru **n030** : Multi-step Frequency Presets  
(Reference 1-6, Jog Frequency)

Factory settings: <b>n030</b> = <b>6.0</b> all others = <b>0.0</b>
---

Range (ea): 0.0 to 9999
-------------------------

Select the PID control Setpoint Reference from either the external terminal FV (for 0-10 VDC), or from multi-step speed parameters, **n024** thru **n030**.

- External terminal FV: Set **n002** to "SEQ=OPR REF=TRM" (" 2 ") or "SEQ=TRM REF=TRM" (" 3 ").
- Multi-step speed parameters: Set **n002** to "SEQ=OPR REF=OPR" (" 0 ") or "SEQ=TRM REF=OPR" (" 1 "). (See Operation Mode Selection, page A1-1, and Multi-step Speed Setting, paragraph 5.19B.)

### C. Feedback Signal Selection

**n044** : Terminal FI Signal Level Selection  
(Terminal FI Sel)

Factory setting: <b>1</b>
---------------------------

Range: 0 or 1
---------------

Select the PID control Feedback Signal from external terminal FI for either a current signal (4-20mA DC) or a voltage (0-10 VDC).

- Current signal: Set **n044** to "4-20 mA" (" 1 ").
- Voltage signal: Set **n044** to "0-10 VDC" (" 0 ").  
( **Must also cut jumper J1 on Control PCB.** )

### D. Inverse PID

NOTE: The following applies only when **n084** = "Enable Rev Fdbk" (" 3 ").

If using inverse PID control, the following adjustments need to be made:

- If a 0-10 VDC reference is used to determine the setpoint, exchange the values in **n048** and **n049**.

EXAMPLE: If the Frequency Reference Gain (**n048**) = " 100 " % and the Frequency Reference Bias (**n049**) = " 0 " %, these parameters will now need to be set as follows:

**n048** = " 0 " %

**n049** = " 100 " %

## 5.22 PID CONTROL

Continued

- If the setpoint is entered via the keypad, the entered setpoint needs to be recalculated as follows:

$$\text{Entered Setpoint} = \text{Max Value (n023)} - \text{Desired Setpoint}$$

This effectively inverts the reference input.

EXAMPLE: Desired Setpoint is 43.0 Hz, Max. Value (**n023**) = " 60.0 " Hz.  
Therefore, the entered setpoint is:

$$\text{Entered Setpoint} = 60.0 \text{ Hz} - 43.0 \text{ Hz} = " 17.0 " \text{ Hz.}$$

This setpoint should be entered as " 17.0 " Hz.

- If PID feedback loss detection is used, the *inverse* of the desired feedback loss detection level should be entered in **n091**.

EXAMPLE: Desired Feedback Loss Level = 7%.

$$\text{Desired Fdbk Loss Det. Level} = 100\% - 7\% = " 93 " \%$$

- E. **n085** : Feedback Calibration Gain  
(PID Fdbk Gain)

Factory setting: <b>1.00</b>
Range: 0.00 to 10.00

This parameter is used to adjust the Feedback Signal level.

### F. Feedback Loss Detection

- n090** : Feedback Loss Detection Selection  
(PID Fdbk Loss Sel)

LED Setting	LCD Setting
0*	Disabled*
1	MF Output Only

- n091** : Feedback Loss Detection Level  
(PID Fdbk Loss Lvl)

Factory setting: <b>0</b> %
Range: 0 to 100 %

- n092** : Feedback Loss Detection Delay Time  
(PID Fdbk Loss Time)

Factory setting: <b>1.0</b> seconds
Range: 0.0 to 25.5 seconds

When enabled (**n090** = "MF Output Only" (" 1 ")), the drive will sense if the Feedback Signal falls below the **n091** level for more than the **n092** delay time.

### G. PID Settings

- n086** : Proportional Gain  
(PID P Gain)

Factory setting: <b>1.0</b>
Range: 0.0 to 10.0

Proportional gain is the value by which the error signal is multiplied to generate the new speed reference.

(continued on next page)

## 5.22 PID CONTROL

Continued

**n087** : Integral Time  
(PID I Time)

Factory setting: <b>10.0</b> seconds
Range: 0.0 to 100.0 seconds

This parameter determines how fast the integral gain increase is added to the control loop.

**n088** : Derivative Time  
(PID D Time)

Factory setting: <b>0.0</b> seconds
Range: 0.00 to 1.00 seconds

Derivative time can be adjusted to dampen initial oscillations and reduce overshoot, which serves to improve stability.

These parameters are all interactive, and will need to be adjusted until the control loop is properly tuned, i.e. stable with minimal steady-state error. A general procedure for tuning these parameters is as follows:

1. Adjust Proportional Gain until continuous oscillations in the Controlled Variable are at a minimum.
2. The addition of Integral Time will cause the steady-state error to approach zero. The time should be adjusted so that this minimal error is attained as fast as possible, without making the system oscillate.
3. If necessary, adjust derivative time to reduce overshoot during startup. The drive's accel and decel rate times can also be used for this purpose.

**H. n089** : Integral Value Limit  
(PID I Limit)

Factory setting: <b>100</b> %
Range: 0 to 109 %

Parameter **n089** is factory set for optimum results for most applications, and generally doesn't need to be changed.

**I. n036** thru **n040** : Multi-function Input Terminals  
(Terminal S2-S6 Sel)

PID I Reset ( **20** ): Integral Value Reset

A Multi-function Input Terminal can be used to reset the value of **n087** to data " 0 ". Note that this value is also reset to " 0 " if the drive is given a STOP command.

PID Disable ( **21** ): PID Disable

A Multi-function Input Terminal can be used to disable PID control. When this terminal is closed, PID control is disabled, and the Setpoint Reference is used as the frequency reference.

## 5.22 PID CONTROL

Continued

**n094** : Sleep Function Start Level  
(Sleep Start Lvl)

Factory setting: **0.0** Hz

Range: 0.0 to 400.0 Hz

**n095** : Sleep Function Delay Time  
(Sleep Delay Time)

Factory setting: **0.0** seconds

Range: 0.00 to 25.5 seconds

This function provides a deadband in drive operation that increases control flexibility, and a scheme to reduce unnecessary operation of the equipment. It is useful for applications which require a minimum operating speed. For example, a pump may have to move at 25% rated speed in order to move liquid. When using the sleep function, a sensed variable like temperature or pressure must deviate by a large enough amount before the drive is allowed to run. For example, the temperature in a space may be allowed to drift past a set point by so many degrees before a fan is started. When the signal from the sensed variable is below a certain point, the drive and motor are off.

This function operates when parameter **n094** (Sleep function start level) is set to some value other than zero and one of the PID modes is selected (**n084** is "Enabled"). The drive starts to run when the PID output (frequency reference) is higher than the setting specified in parameter **n094** for longer than the time entered into parameter **n095** (Sleep function delay time) has elapsed. The drive stops running when the PID output drops below the value in parameter **n094** for longer than the time entered into parameter **n095**.

**Sleep Function Timing Chart**

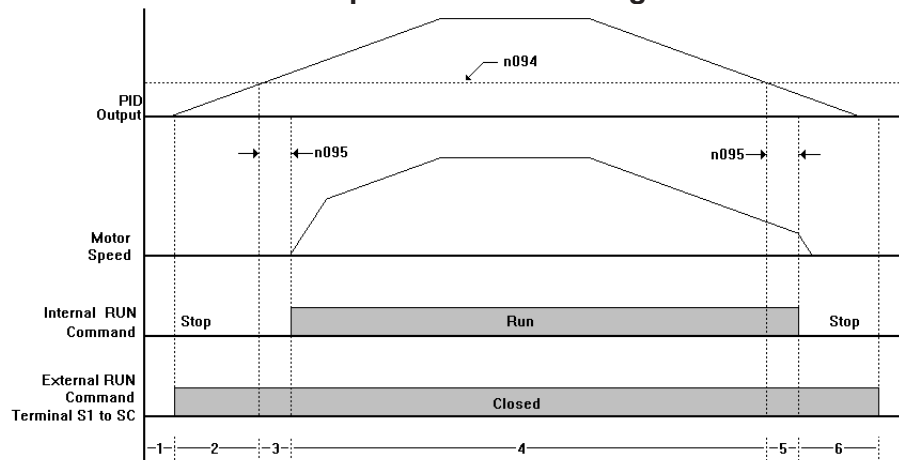

See timing chart:

1. The drive is stopped.
2. External Run is closed, but the PID output is below the sleep function start level (**n094**). The drive remains stopped.
3. The PID output exceeds the sleep function start level (**n094**), and the sleep function time delay timer (**n095**) starts timing.
4. The sleep function delay timer (**n095**) expires and the drive accelerates on the acceleration ramp to "catch up" with PID output. The drive then follows the PID output.
5. The PID output level falls below the sleep function start level (**n094**). The sleep function time delay timer (**n095**) starts timing. The drive still follows PID output.
6. The sleep function delay timer (**n095**) expires and the drive decelerates on the deceleration ramp.

## 5.23 RESET CODES: 2-WIRE, 3-WIRE INITIALIZATION

**n001** : Parameter Selection / Initialization  
(Password)

Factory setting: **1**

Range: 0 to 9

The following table shows which parameters can be programmed (displayed & changed) or only displayed when **n001** is selected.

LED & LCD Setting	Programmable Parameters	Display Only Parameters
0	n001	n002 to n116
1	n001 to n035	n036 to n116
2	n001 to n053	n054 to n116
3	n001 to n116	—
4 - 7	Not Used	
8	Initialization: 2-Wire control	
9	Initialization: 3-Wire control	

By entering either initialization code into **n001**, a reset to factory configuration (parameter initialization) is accomplished. The parameters which are NOT affected are: **n005** (Motor Rotation), **n010** (V/f selection), and **n115** (Inverter kVA Sel).

Factory Settings	2-Wire Control		3-Wire Control	
	LED	LCD	LED	LCD
n036	0	Reverse RUN	1	STOP Command
n037	2	Ext Fault (NO)	--	FWD / REV Cmd (3W)
n038	4	Fault Reset	4	Fault Reset
n039	10	Multi-step Spd 1	10	Multi-step Spd 1
n040	11	Multi-step Spd 2	11	Multi-step Spd 2

### CAUTION

Know your application before using either Initialization function of **n001**. This parameter must be set to " 0 " to " 3 " for operation.

" 8 " = Factory 2-Wire Control Initialization (Maintained RUN Contact)

" 9 " = Factory 3-Wire Control Initialization (Momentary START/STOP Contact)

Entering either Initialization code resets all parameters to factory settings, and automatically returns **n001** setting to " 1 ". If the drive is connected for 3-Wire control and this parameter is set to " 8 " (2-Wire Control Initialization), the motor may run in reverse direction WITHOUT A RUN COMMAND APPLIED. Equipment damage or personal injury may result.

### IMPORTANT

After " 8 " or " 9 " has been entered in **n001**, the Motor Rated Current (**n033**) MUST BE REPROGRAMMED to the correct setting for the application. See paragraph 5.26.



## 5.23.1 SLIP COMPENSATION

**n107** : Slip Compensation Gain  
(Slip Comp Gain)

Factory setting: **0.0** %

Range: 0.0 to 9.9 %

Slip compensation is used to increase motor speed to account for slip; the drive accomplishes this by automatically boosting output frequency, with a corresponding boost in output voltage.

This parameter sets the slip compensation gain, in increments of 0.1%. When the gain is 1.0, the output frequency is increased by 1% of the **n013** setting at rated current. A setting of 0.0 results in no slip compensation.

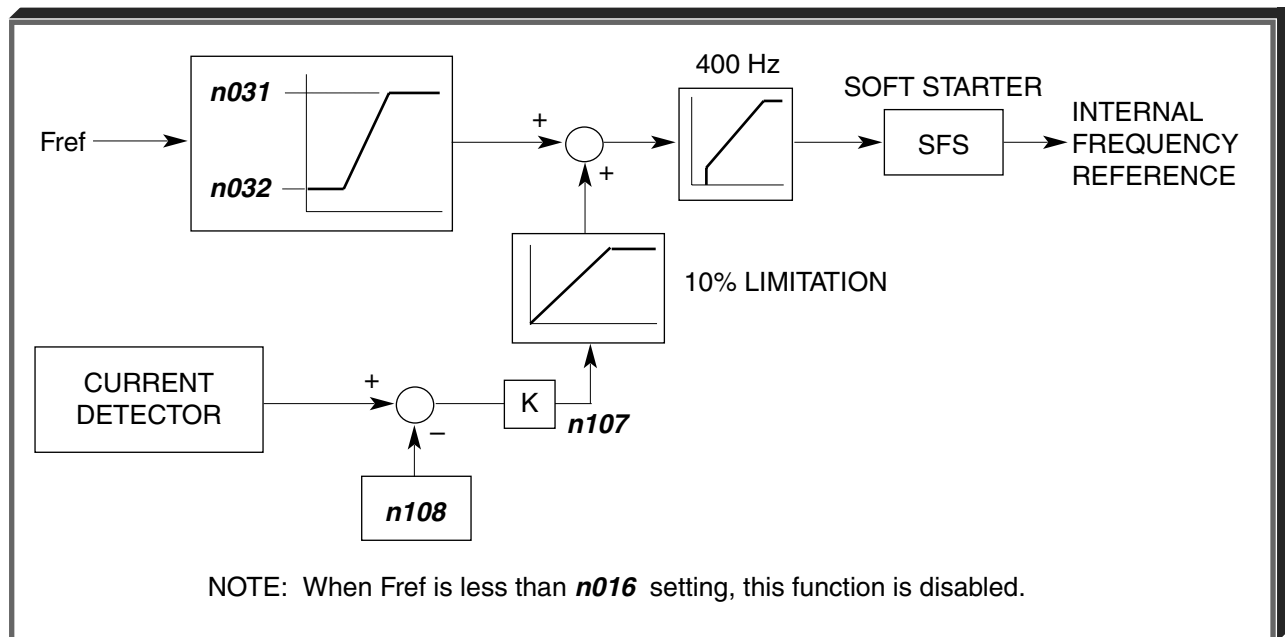

**Slip Compensation Block Diagram**

### EXAMPLE:

Desired frequency is 45 Hz  
 Motor slip = 3% at full load  
 (**n107 = 3.0**)  
 Actual output frequency at  
 full load =  $45 \times 1.03 = 46.35$  Hz

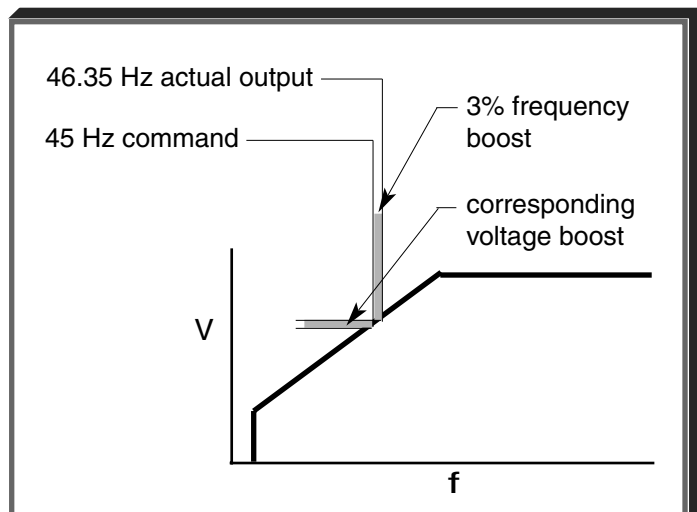

### 5.23.1 SLIP COMPENSATION

Continued

***n108*** : Motor No-Load Current  
(Mtr No-Load Amp)

Factory setting: <b>2.0</b> sec.
----------------------------------

Range: 0.0 to 25.5 sec.
-------------------------

Motor no-load current (***n108***) is set as a percentage of motor full-load current (***n033***). It is used as shown in the slip compensation block diagram. The factory setting of 30% should be sufficient for most motors.

***n109*** : Slip Compensation Primary Delay  
Time Constant  
( Slip Comp Delay)

Factory setting: <b>2.0</b> sec.
----------------------------------

Range: 0.0 to 25.5 sec.
-------------------------

Parameter (***n109***) can be increased to improve stability or decreased to improve response to load changes.

## 5.24 STALL PREVENTION

### A. *n072* : Stall Prevention During Deceleration (StallP Decel Sel)

Factory setting: **1**

LED Setting	LCD Setting	Description
0	Disabled	Stall Prevention during deceleration disabled
1 *	Enabled *	Stall Prevention during deceleration enabled

Stall prevention during deceleration automatically adjusts the deceleration rate while monitoring the DC bus voltage to prevent overvoltage during deceleration.

When the motor load is large or decel time is short, actual decel time may be longer than the set value because of stall prevention.

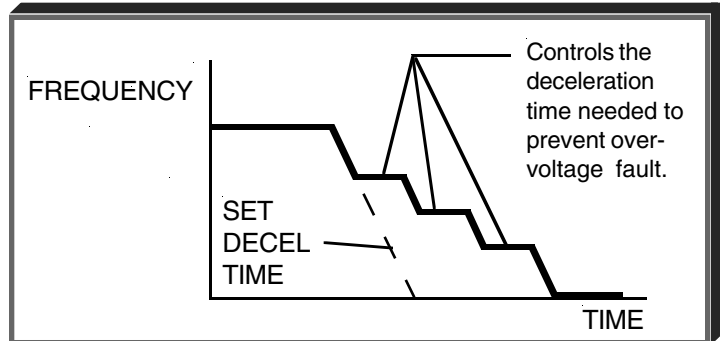

### ⚠ WARNING

If *n072* = "Enabled" (" 1 ") and a high line voltage is present (more than 10% above drive rating), the drive may not stop when a STOP command is issued. This parameter should be set to "Disabled" (" 0 ") if this condition is suspected to exist.

### B. *n073* : Stall Prevention Level During Acceleration (StallP Accel Lvl)

Factory setting: See Table A3-1

Range: 30 - 200 %

This parameter determines the actual drive output current level during an acceleration condition. Set in percent of drive rated output current (see Appendix 2).

A setting of " 200 " disables stall prevention during acceleration. During acceleration, if the output current exceeds the value in *n073*, acceleration stops and frequency is maintained. When the output current goes below the value set in *n073*, acceleration resumes.

In the constant horsepower region [actual output frequency > max. voltage frequency (*n013*)], the stall prevention level during acceleration is changed by the following formula:

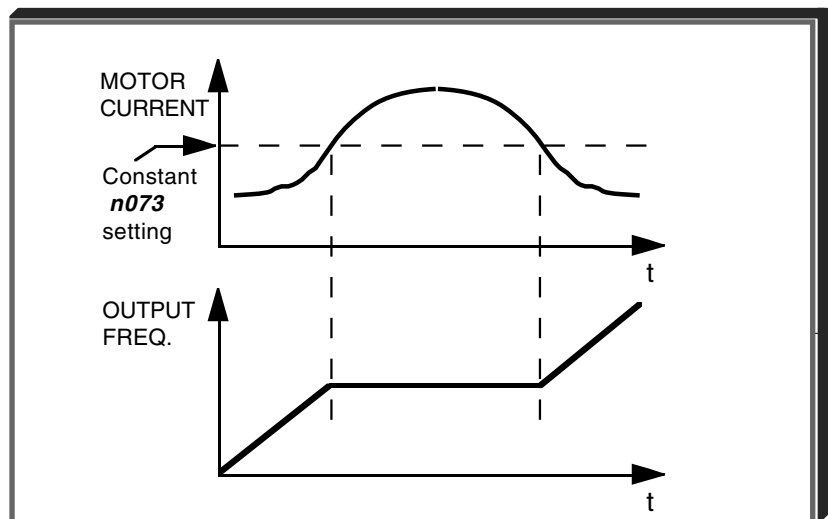

$$\text{Stall prevention level during accel (constant horsepower)} = \text{Stall prevention level during accel} \times \frac{\text{Max. voltage frequency}}{\text{Actual output frequency}}$$

## 5.24 STALL PREVENTION

Continued

### C. *n074* : Stall Prevention Level At Set Speed (StallP Run Lvl)

Factory setting: See Table A3-1

Range: 30 - 200 %

This parameter determines the actual drive output current level while operating at set speed (frequency). Set in percent of drive rated output current (see Appendix 2).

A setting of " 200 " disables stall prevention at set speed. During running at set speed, if the output current exceeds the value set in *n074*, the drive will begin to decelerate. When the output current goes below the value set in *n074*, acceleration begins, up to the set frequency.

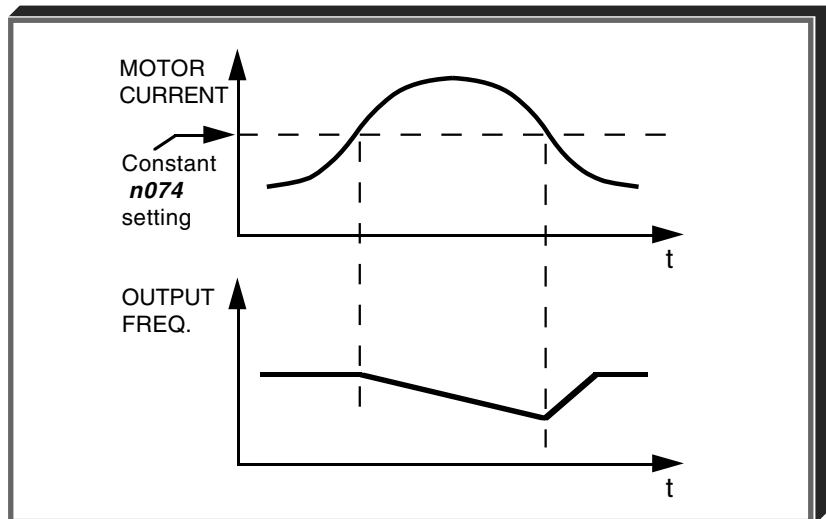

## 5.25 STOPPING METHOD

### *n004* : Stopping Method

Selects the stopping method suitable for the application.

LED Setting	LCD Setting	Description
0*	Ramp to STOP*	Deceleration (ramp) to stop
1	Coast to STOP	Coast to stop
2	Coast w/Timer 1	Coast to stop with Timer 1
3	Coast w/Timer 2	Coast to stop with Timer 2

#### A. Ramp to STOP ( 0 ) : Deceleration to Stop

Upon removal of the FWD (or REV) Run command, the motor decelerates at the deceleration rate determined by the time set in Decel Time 1 (*n019*), and DC injection braking is applied immediately before stop. If the decel time is too short or the load inertia is too large, an overvoltage (OV) fault may occur on a stop command — the decel time must be increased.

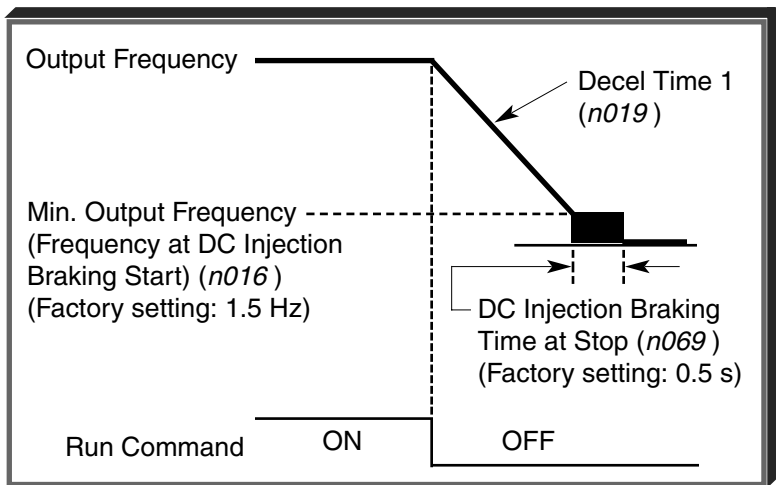

#### B. Coast to STOP ( 1 ) : Coast to Stop

Upon removal of the FWD (or REV) Run command, the motor coasts to rest.

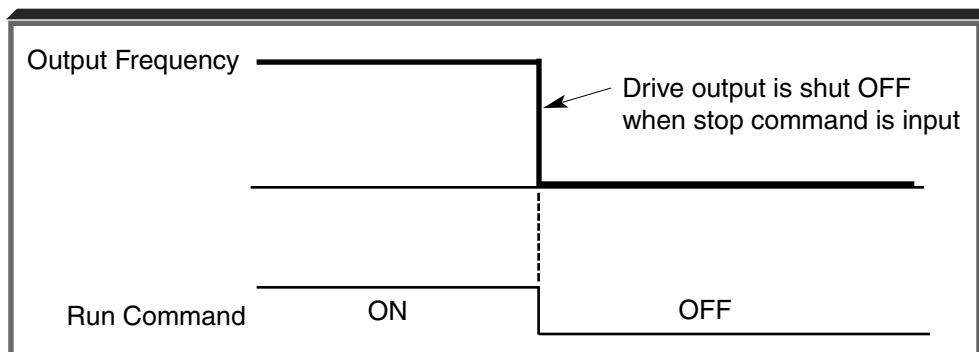

## 5.25 STOPPING METHOD Continued

### C. Coast w/Timer 1 ( 2 ) : Coast to Stop With Timer 1

When programmed for coast to stop with timer 1, a Run command is ignored if issued during the time the motor would normally be decelerating (**n019** or **n021**), or for the minimum base block time (**n057**), whichever is longer.

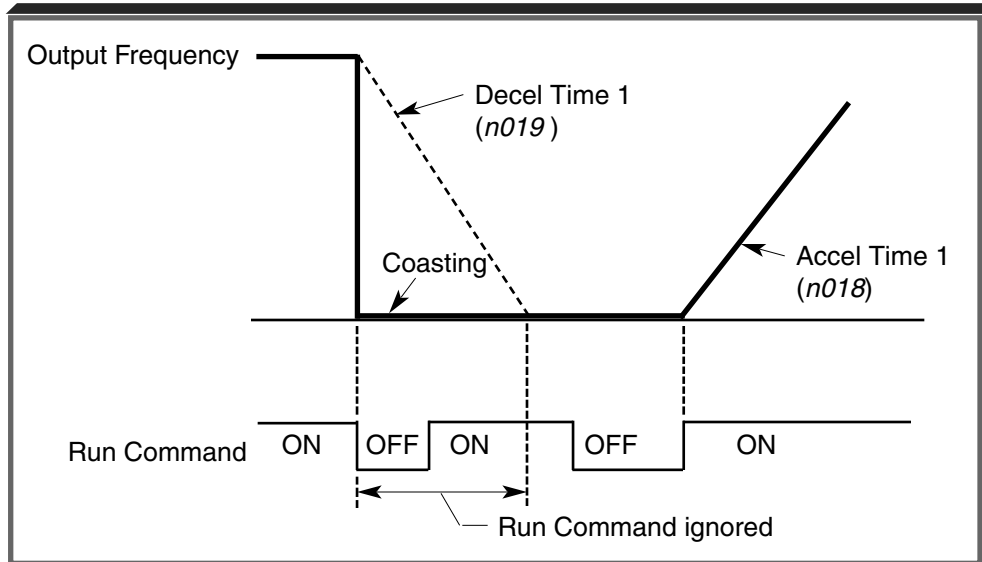

### D. Coast w/Timer 2 ( 3 ) : Coast to Stop With Timer 2

When programmed for coast to stop with timer 2, a Run command is retained, but is not responded to, until after the time the motor would normally have decelerated to a stop (**n019** or **n021**), or for the minimum base block time (**n057**), whichever is longer.

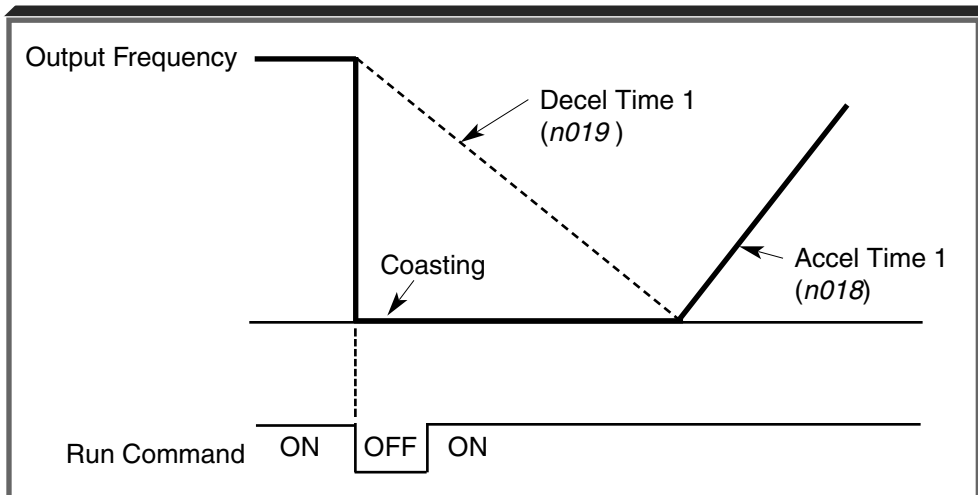

## 5.26 THERMAL OVERLOAD PROTECTION

**n033** : Motor Rated Current  
(Motor Rated FLA)

Factory setting: See Table A3-1
Range: see description

This parameter should be set, in increments of 0.1 A, to the rated current (FLA) value shown on the motor nameplate; this value **MUST BE** between 10% and 120% of the *drive rated current* (refer to Specifications in Appendices 2 & 3 of this manual). If the motor FLA does not fall within this range, a different Model No. drive must be used.

NOTE: Setting **n033** to " 0.0 " disables the motor overload protection function, regardless of the setting of **n034** .

**n034** : Electronic Thermal Motor Protection  
(Motor OL Sel)

LED Setting	LCD Setting	Description
0	Disabled	Electronic thermal overload protection disabled
1*	<b>STD Motor/8 Min *</b>	General-purpose motor, standing rating (8 min.)
2	STD Motor/5 Min	General-purpose motor, short-term rating (5 min.)
3	INVMotor/8 Min.	Blower-cooled motor, standard rating (8 min.)
4	INVMotor/5 Min.	Blower-cooled motor, short-term rating (5 min.)

The drive protects against motor overload with a UL-recognized, built-in electronic thermal overload relay.

The electronic thermal overload function monitors motor temperature, based on drive output current and time, to protect the motor from overheating. When the electronic thermal overload trips, an " **oL1 Overload 1**" error occurs, shutting OFF the drive output and preventing excessive overheating of the motor.

When operating with one drive connected to only one motor, an external thermal relay is not needed. When operating several motors with one drive, install a thermal overload relay on each motor.

## 5.26 THERMAL OVERLOAD PROTECTION

Continued

- **General-purpose and blower-cooled motors**

Induction motors are classified as general-purpose or blower-cooled motors, based on their cooling capabilities; the motor overload detection function operates differently, as shown, for each of these two motor types.

NOTE: If a TEFC motor is going to be run at or near 100% of rated current at frequencies below 30 Hz for an extended period of time, select the blower cooled curve (n034 = "INV Motor/8 Min" (" 3 ")).

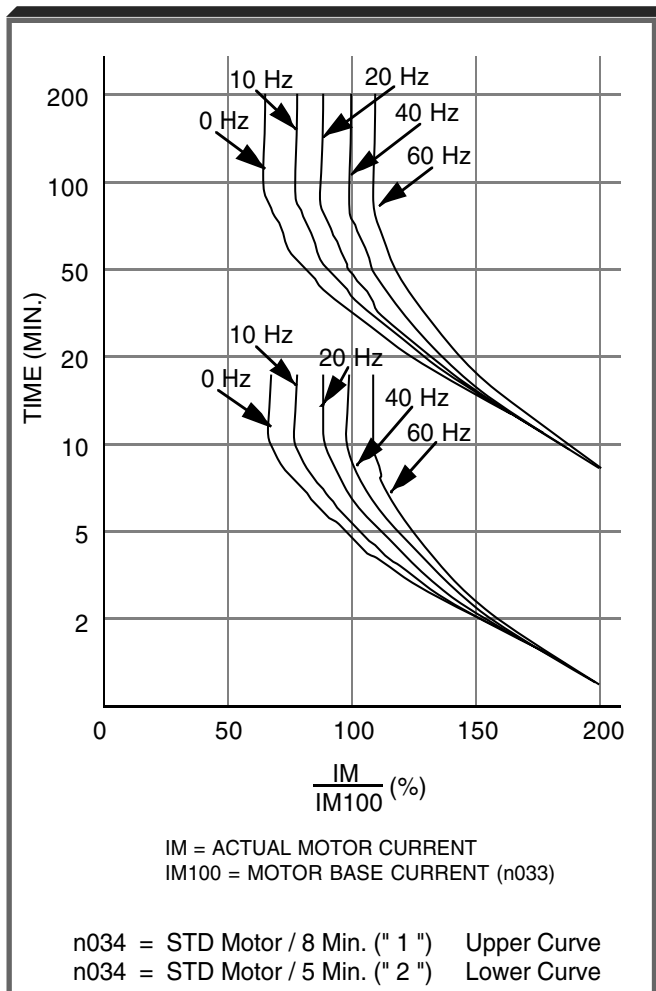

**Electronic Motor Thermal Protection Characteristics For General-Purpose Motor**

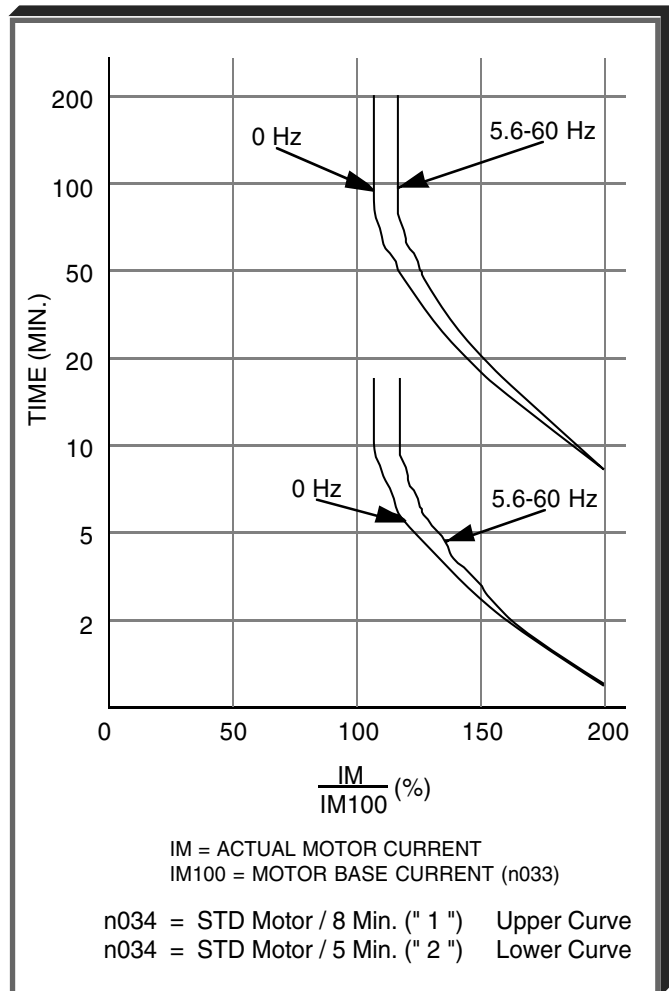

**Electronic Motor Thermal Protection Characteristics For Blower-Cooled Motor**



## 5.27 TORQUE COMPENSATION

**n071** : Torque Compensation Gain (K<sub>T</sub>)  
(Torq Comp Gain)

Factory setting: **1.0**

Range: 0.0 to 3.0

Sets the torque compensation, in increments of 0.1. When the motor has the same capacity as that of the drive, the gain is 1.0. When a smaller motor is used, the gain should be set to 1.5 (typical).

This parameter is used by the drive's automatic torque boost function to match the drive's output voltage boost to the motor load. Except for the most demanding of high starting torque applications, the factory settings of these parameters will be adequate. The factory settings are programmed to match the performance characteristics of typical AC motors.

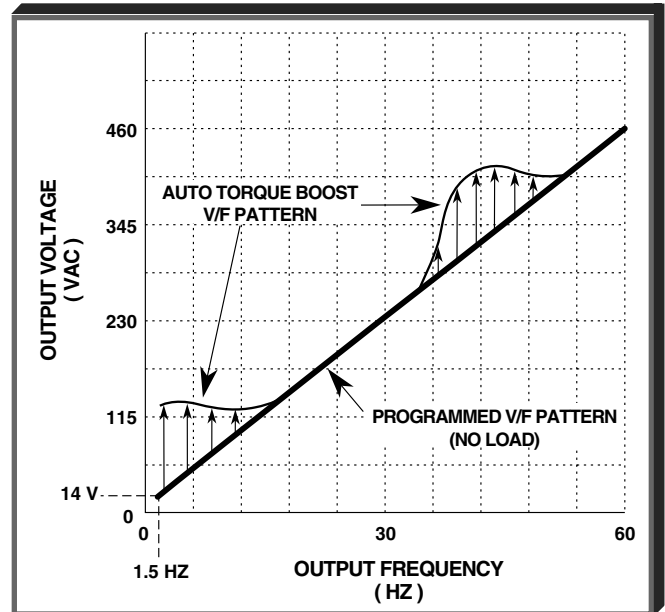

**Example of Torque Compensation Operation**

The calculation of compensated torque uses the following formula:

$$\text{Compensated Value} \left[ \frac{(\sqrt{3} \cdot V_{ac} \cdot I_{ac} \cdot \cos \Phi)}{\text{Frequency}} \right] \times K_T$$

Where

K<sub>T</sub> = **n071**

Φ = Power Factor (calculated by the drive)

## 5.28 V/f PATTERN

### A. n010: V/f Pattern

LED Setting	LCD Setting	Description
0	User Defined V/f	"Custom" pattern
1*	60 Hz Preset *	"Preset" pattern

When parameter **n010** is set to "User Defined V/f" ("0"), the V/f pattern can be tailored to suit a specific application and load characteristics by adjusting parameters **n011** to **n017** (see the V/f characteristics figure on the following page). The values set into **n011** to **n017** from the factory should be adequate for most variable torque applications (60 Hz rated motors only).

When parameter **n010** is set to "60 Hz Preset" ("1"), the V/f pattern is fixed. This fixed pattern is good for most constant torque applications (60 Hz rated motor only).

If motor rated voltage is other than 230Vac (e.g. 208Vac, 380Vac, 460Vac or 600Vac), set parameter **n010** = 0 and adjust **n012**, **n015**, and **n017** according to footnote 5 below.

**Table 5-4. Recommended V/f Patterns**

Max. Freq.	Starting Torque	Load Type <sup>1</sup>	n010	n011 (Hz)	n012 (V) <sup>5</sup>	n013 (Hz)	n014 (Hz)	n015 (V) <sup>5</sup>	n016 (Hz)	n017 (V) <sup>5</sup>
50	Normal	VT	0	50.0	230.0	50.0	25.0	40.2	1.3	9.2
50	High <sup>2</sup>	VT	0	50.0	230.0	50.0	25.0	57.5	1.3	11.5
60	Normal	VT	0	60.0	230.0	60.0	30.0	40.2	1.5	9.2
60	High <sup>2</sup>	VT	0	60.0 <sup>3</sup>	230.0 <sup>3</sup>	60.0 <sup>3</sup>	30.0 <sup>3</sup>	57.5 <sup>3</sup>	1.5 <sup>3</sup>	11.5 <sup>3</sup>
50	Normal	CT	0	50.0	230.0	50.0	3.0	17.2	1.5	11.5
50	Medium	CT	0	50.0	230.0	50.0	2.5	23.0	1.3	13.8
50	High <sup>2</sup>	CT	0	50.0	230.0	50.0	2.5	28.7	1.3	16.1
60	Normal	CT	1 <sup>4</sup>	60.0 <sup>4</sup>	230.0 <sup>4</sup>	60.0 <sup>4</sup>	3.0 <sup>4</sup>	17.2 <sup>4</sup>	1.5 <sup>4</sup>	11.5 <sup>4</sup>
60	Medium	CT	0	60.0	230.0	60.0	3.0	20.7	1.5	13.8
60	High <sup>2</sup>	CT	0	60.0	230.0	60.0	3.0	28.7	1.5	23.0
72	Normal	CT	0	72.0	230.0	60.0	3.0	17.2	1.5	11.5
90	Normal	CT	0	90.0	230.0	60.0	3.0	17.2	1.5	11.5
120	Normal	CT	0	120.0	230.0	60.0	3.0	17.2	1.5	11.5
180	Normal	CT	0	180.0	230.0	60.0	3.0	17.2	1.5	11.5

#### NOTES:

- <sup>1</sup> VT = Variable Torque, typically used for blowers, centrifugal pumps, and fans.  
 CT = Constant Torque, most other applications. Consult Yaskawa for further assistance.

*The following conditions must be considered when selecting a V/f pattern:*

- Pattern matches the voltage-frequency characteristics of the motor.
  - Maximum motor speed.
- <sup>2</sup> V/f pattern for high starting torque should be selected for:
- Long wiring distance.
  - Large voltage drop at start
  - AC reactor connected to drive input or output.
  - Use of motor rated below drive max. output.
- <sup>3</sup> These are the factory settings when n010 = "User defined V/f" ("0").
- <sup>4</sup> These settings cannot be changed when n010 = "60 Hz Preset" ("1").
- <sup>5</sup> Voltages shown are for 230V motors; for other motor voltages, multiply all voltage (V) values by (Vmtr/230); i.e., for 460V input, multiply by 460/230 = 2; for 600V input, multiply by 600/230 = 2.6087.

## 5.28 V/f PATTERN Continued

- n011** : Frequency – Max. (Fmax)
- n012** : Voltage – Max. (Vmax)
- n013** : Frequency – Max. Voltage point (FA)
- n014** : Frequency – Midpoint (FB)
- n015** : Voltage – Midpoint (Vc)
- n016** : Frequency – Min. (Fmin)
- n017** : Voltage – Min. (Vmin)

These seven parameters define the custom V/f pattern, **only if n010 is set to "User Defined V/f" ("0")**. The illustration below shows how these constants relate to each other in establishing the custom V/f pattern.

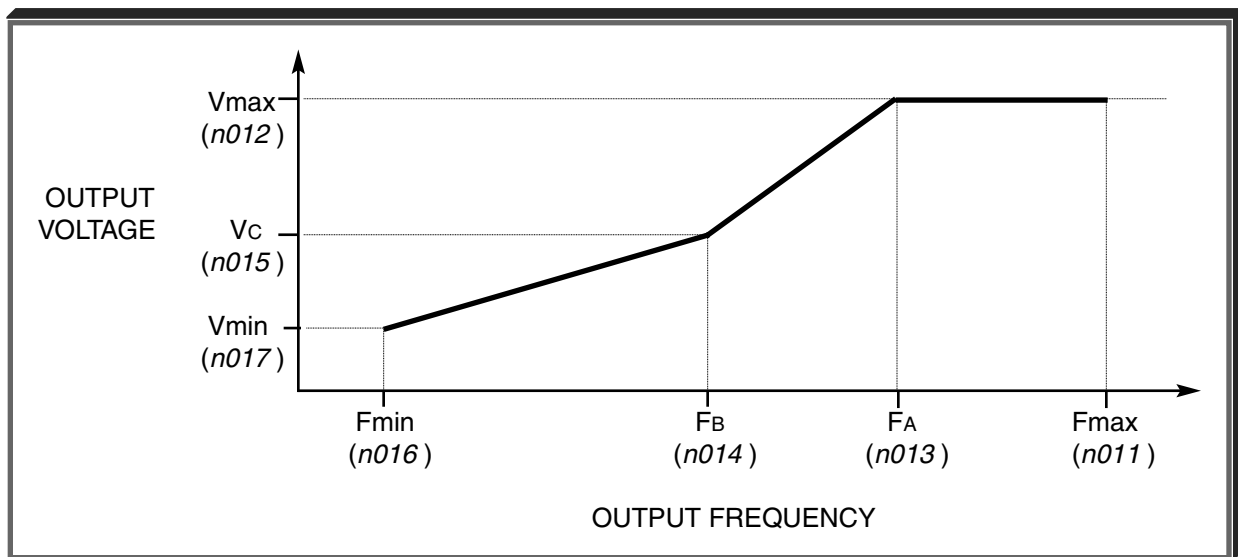

**V/f Characteristics Set by n011 thru n017**

- B. n003** : Motor Rated Voltage  
(Input Voltage)

Factory Setting: **230.0, 460.0 or 575.0 V**

Range: 150.0 to 255.0 V (230V)

150.0 to 510.0 V (460V)

150.0 to 733.1 V (575V)

This parameter should be set to match the motor rated voltage when using the preset V/f pattern (**n010** = "60 Hz Preset" ("1")). The voltages (**n012**, **n015**, and **n017**) will automatically be multiplied by **n003** / 230V. If parameter **n010** = "User defined V/f" ("0"), parameter **n003** will have no effect.

**NOTES:**

<sup>6</sup> Parameter **n003** is also represented by the Vmtr Quick-Start display - see paragraph 4.2.1, "Input Voltage".

## 5.28 V/f PATTERN Continued

NOTE: To establish a V/f pattern with a straight line from Fmin to FA, set FB = Fmin. The setting of Vc is then disregarded and does not affect the V/f pattern.

### IMPORTANT

The parameter settings are checked whenever power is applied to the drive, or each time the **ENTER** key is pressed while in the Program (PRGM) mode. A parameter set value failure ("**oPE5 V/f Error**") will occur if any part of the following relationships among **n011** thru **n017** is not TRUE:

- (a)  $F_{max} \geq F_A \geq F_B \geq F_{min}$
- (b)  $V_{max} \geq V_c \geq V_{min}$

## 5.29 INPUT PHASE LOSS DETECTION

**n083** : Input Phase Loss Detection Level  
(In Ph Loss Lvl)

Factory setting: <b>7</b> %
-----------------------------

Range: 1 to 100 %
-------------------

The input phase loss detection circuit monitors the DC bus current ripple and activates when one of the input phases is lost. The detection circuit calculates the maximum and minimum values of the DC bus voltage in 1.28 second intervals, and compares the difference ( $\Delta V$ ) between these values with the input phase loss detection level (**n083**). If  $\Delta V \geq \mathbf{n083}$ , then an input phase loss is detected, and after the 10.24s, an SPI fault occurs, the display shows "SPi Input PhaLoss" and the motor coasts to stop.

Input phase loss detection is disabled in the following cases:

- Parameter **n083** is set to data " 100 ".
- A Stop command is input.
- Magnetic Contactor (MC) shuts OFF.
- CPU A/D converter fault (CPF5).
- During acceleration.
- Output current  $\leq 30\%$  of drive rated current.

# Section 6. FAULT INDICATION AND TROUBLESHOOTING

## 6.1 GENERAL

A failure in the GPD 506/P5 can fall into one of two categories, Alarm or Fault.

A blinking "Alarm" indication is a warning that a drive trouble condition will soon occur, or that a problem exists in the external circuitry. The drive will continue to operate during an "Alarm" indication. "Alarm" indications are not entered into the fault register.

A steady "Fault" indication is displayed when the drive's Fault relay has tripped (drive shutdown). The motor coasts to a stop, and a fault signal output is present at control circuit terminals MA, MB, & MC, if parameter **n041** is programmed for fault output "Fault" ("0").

**Table 6-1. Alarm Indication and Details**

INDICATION (DISPLAY)	PROBLEM	DESCRIPTION
<b>bb</b> Base Block (blinking)	External Base Block command	Base Block command at multi-function terminal is active, shutting off drive output (motor coasting). Temporary condition, cleared when input command is removed.
<b>CALL</b> Waiting Message (blinking)	Communication ready	Drive is waiting for the PLC to establish communication (only when <b>n002</b> is set for Sequence or Reference from Serial Communications).
<b>CE</b> Modbus Com Err (blinking)	Modbus transmission fault	Control data cannot be received normally – condition has lasted longer than 2 seconds.
<b>EF</b> Ext Fault (blinking)	Simultaneous forward and reverse operation commands	Fwd Run and Rev Run commands are both closed for more than 0.5 sec. Removing one of the commands will allow drive operation.
<b>oH1</b> Overheat 1 (blinking)	Heat sink overheated	Fin temperature exceeds 90° C (194° F); drive is programmed for operation to continue.
<b>oH3</b> Overheat 3 (blinking)	External overheat	External temperature monitoring circuit(s) detected an overtemperature condition and produced an input signal. <b>See paragraph 5.19, Data 23.</b>
<b>oL3</b> Overload 3 (blinking)	Overload	Drive output torque exceeds the set Overtorque Detection level ( <b>n078</b> ); Drive is programmed to continue operation at overtorque.
<b>oPE1 (1)</b> KVA Setting Err	kVA parameter setting fault	kVA setting ( <b>n115</b> ) is incorrect.
<b>oPE3 (1)</b> MF Input Error	Parameter set value fault	<b>n036 to n040</b> (multi-function input) set value fault. <b>See paragraph 5.19 for description.</b>
<b>oPE5 (1)</b> V/f Error	Parameter set value fault	<b>n011 to n017</b> (V/f data) set incorrectly.
<b>oPE6 (1)</b> Parameter Error	Parameter set value fault	One of the following conditions was detected: <ul style="list-style-type: none"> <li>• <b>n062 &gt; n063</b> (prohibit frequencies)</li> <li>• <b>n031 &lt; n032</b> (frequency reference limits)</li> <li>• <b>n043 = "FV = RST FI MSTR"</b> ("2") and <b>n036 thru n040 = "Master Fref Sel"</b> ("9")</li> <li>• <b>n043 = "FV = RST FI MSTR"</b> ("2") and <b>n084 ≠ "Disabled"</b> ("0")</li> </ul>
<b>ov</b> Overvoltage (blinking)	Overvoltage	Internal monitor of DC Bus voltage indicates that input AC power is excessively high, while drive is in stopped condition.
<b>Uv</b> Undervoltage (blinking)	Low voltage (Power UV)	Internal monitor of DC Bus voltage indicates that input AC power is below Undervoltage detection level, while the drive is stopped.

**NOTES:**

- (1) These displays occur only when in the Program mode, when exiting from Program mode, or when applying power to the drive.

**Table 6-2. Fault Indication and Details**

INDICATION (DISPLAY)	FAULT	DESCRIPTION
<b>CE</b> Modbus Com Err	Modbus transmission error	Control data cannot be received normally — condition has lasted longer than 2 seconds.
<b>CPF0 (1)</b> Com-Err (Op + Inv)	Transmission error or control function hardware fault (including internal RAM, external RAM or PROM)	Transmission between drive and remote operator is not established within 5 seconds after the power supply is turned on. (Displayed on the remote operator.)
<b>CPF1 (1)</b> Com-Err (Op + Inv)	Transmission error	Transmission error occurs 2 seconds or more <u>after</u> transmission has first been established.
<b>CPF4 (1)</b> EPROM Error	EPROM fault	Drive failure.
<b>CPF5 (1)</b> External A/O Err	A/D converter failure in CPU	Drive failure.
<b>EFO</b> Opt External Flt	External fault – serial communication	Fault condition occurred in the external communication circuit(s).
<b>EF_</b> External Fault _	Ext. fault signal at term. S_ ("_" represents a digit 2-6)	A fault condition has occurred in the external circuit(s) monitored by the contact providing input to the indicated terminal.
<b>Err</b> EPROM R/W Err	Parameter write-in fault	Temporary display, in Program mode, indicating that parameter setting was not written into EPROM memory.
<b>GF</b> Ground Fault	Ground fault protection	Ground current exceeded approx. 50% of the drive rated current.
<b>oC (2)</b> Overcurrent	Overcurrent	Drive output current exceeds 200% of drive rated current for GPD506V-A003 thru -A068 (CIMR-P5M20P41F thru 20151F), -B001 thru -B034 (40P41F thru 41P51F), and 51P51F thru 51600F; or 180% for all other ratings.
<b>oH1</b> Overheat 1	Heat sink overheated	Fin temperature exceeds 95°C (203°F), or internal cooling fan has failed.
<b>oH2</b> Overheat 2	Heat sink overheated	Fin temperature exceeds 105°C (221°F)
<b>oL1</b> Overload 1	Motor overload	Thermal motor overload protection has tripped.
<b>oL2 (2)</b> Overload 2	Drive overload	Drive overload protection has tripped.
<b>oL3</b> Overload 3	Overtorque	Drive output torque exceeds the set Overtorque Detection level ( <b>n078</b> ), and drive is programmed for coast to stop at overtorque detection.
<b>oPr</b> Operator Failure	Operator disconnect	Digital Operator has been disconnected. Check <b>n110</b> .
<b>ov</b> Overvoltage	Overvoltage (OV)	Detection level: Approx. 410VDC for 230V rated unit; approx. 820VDC for 460V rated unit; approx. 1050VDC for 600V rated unit.
<b>PUF</b> DC Bus Fuse	Fuse blown	DC Bus fuse has cleared. Check for short circuit in output, and check main circuit transistors.
<b>rr</b> Dyn Brk Trans	Regenerative transistor failure	Dynamic Braking resistor has failed.
<b>rH</b> Dyn Brk Res	Braking resistor unit overheated	Dynamic Braking resistor has overheated.

**Table 6-2. Fault Indication and Details - Continued**

INDICATION (DISPLAY)	FAULT	DESCRIPTION
<b>SC</b> Short Circuit	Load short-circuit	Drive output has been short-circuited.
<b>SP i</b> Input Pha Loss	Input open-circuit	Drive input has an open-circuit in one or more phase.
<b>Uv1</b> Undervoltage 1	Low voltage (Power UV)	Occurs two seconds after detection of low voltage. Detection level: 230V drive = 190 VDC or less; 460V drive = 380 VDC or less; 600V drive = 546 VDC or less.
<b>Uv2</b> Undervoltage 2	Low voltage (Control UV)	Control circuit voltage levels below acceptable levels during operation.
<b>Uv3</b> Undervoltage 3	Low voltage (MC fault)	Main circuit (precharge) magnetic contactor not operating correctly.

NOTES:

- (1) These are all Control PCB hardware faults – see Troubleshooting Chart 6.9.
- (2) Note that circumstances leading to these faults stress the drive’s output devices - do not simply reset the fault without following procedure in Troubleshooting Chart 6.5 or 6.6.



## 6.2 DISPLAYING FAULT SEQUENCE

**A.** If a fault is reset either from the digital operator or a multi-function input, **ALL FAULT INFORMATION WILL BE LOST.**







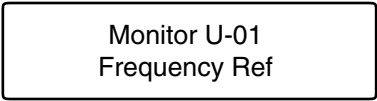

**B.** If one or more faults occur simultaneously and are NOT reset (by digital operator, multi-function input, or cycling power), up to four faults can be displayed by pressing the “up arrow” key.

**C.** Whenever the Fault relay trips and power is removed from the drive without the fault being reset, the display code of the fault that caused the trip (except for Illegal Constant [ **oPE\_** ] or Control Function Error [ **CPF\_** ] ) is entered into a register in NV-RAM memory. This register retains, in sequence, that fault code and those of up to three immediately following the shutdown.

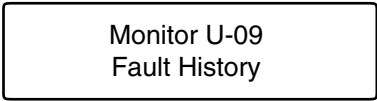
A newly occurring fault code will not change the fault register if it is a recurrence of the most recently entered fault.

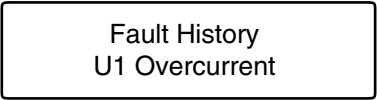
The contents of this register can be displayed by following the steps in Table 6-3.

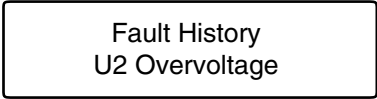
**Table 6-3. Displaying Fault Sequence After Power Cycle**

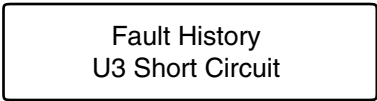
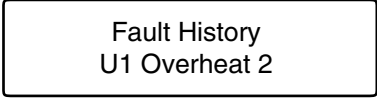
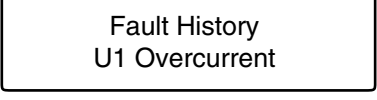
STEP	OPERATION PROCEDURE	DIGITAL OPERATOR DISPLAY
1	Press  until the Keypad display shows " Monitor U-01 Frequency Ref ".	
2	Press  until " Monitor U-09 Fault History " appears on the display.	
3	Press  .	
4	Press  . The display indicates that this is currently the next code in the memory register.	
5	Continue pressing  to display the other codes in the memory register. After the last register code is displayed, the sequence will return to the first code.	  

After the fault sequence has been examined, troubleshoot the most recent fault before entering a Fault Reset command (by Digital Operator **STOP/RESET** key or external signal at term. S4) to prepare the drive for restart of operation.

## 6.3 TROUBLESHOOTING FLOWCHARTS

If the GPD 506/P5 Drive malfunctions, locate the cause and take corrective action by following the flowcharts given in this section.

### A. TROUBLESHOOTING MOTOR SYMPTOMS

Motor Does Not Rotate .....	Chart 6.1
Motor Stalls During Acceleration .....	Chart 6.2

### B. TROUBLESHOOTING FOR FAULT CONDITIONS

Overvoltage (ou) Fault Indication .....	Chart 6.3
Blown Fuse (PUF) Fault Indication .....	Chart 6.4
Overcurrent (oC) Fault Indication .....	Chart 6.5
Overload (oL) Fault Indication .....	Chart 6.6
Undervoltage (Uu) Fault Indication .....	Chart 6.7
Control Function Error (CPF_ ) Fault Indication .....	Chart 6.8
External Fault (EF_ ) Indication .....	Chart 6.9
No Digital Operator Display .....	Chart 6.10

### WARNING

Oscilloscope chassis may be at voltages potentially hazardous to life if not properly grounded. If oscilloscope is used to measure high voltage waveforms, use only a dual channel oscilloscope in the differential mode with X100 probes. Always connect oscilloscope chassis to earth ground.

### WARNING

Voltages dangerous to life exist when equipment is open and energized. Do not work alone.

### CAUTION

To prevent equipment damage always remove incoming three-phase power before test equipment is connected or removed.

### CAUTION

If the Drive Control PCB is replaced, ALL Drive CONSTANTS MUST BE REPROGRAMMED for your application.

# TROUBLESHOOTING CHART 6.1

## MOTOR DOES NOT ROTATE

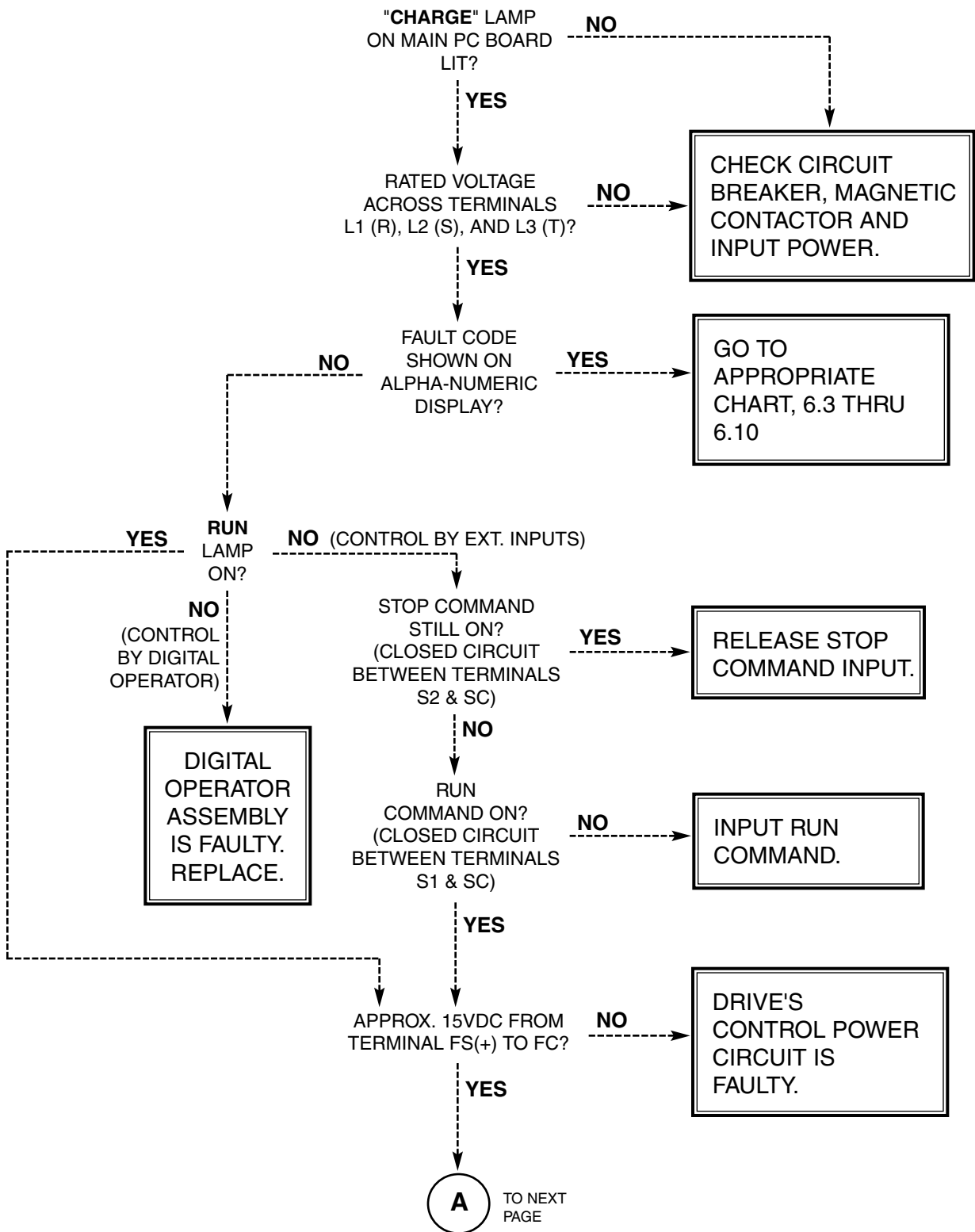

**TROUBLESHOOTING CHART 6.1 - Continued**

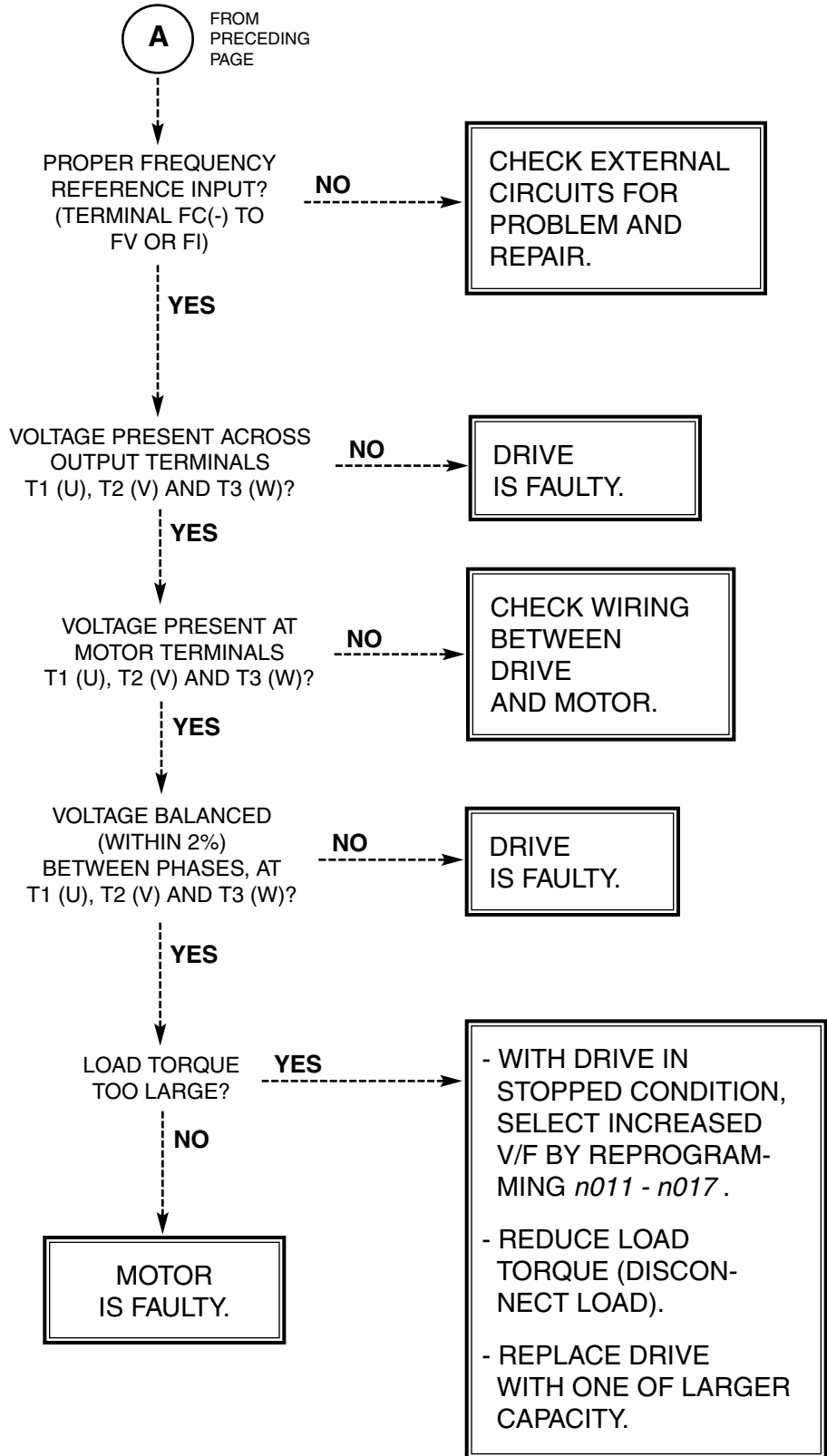

## TROUBLESHOOTING CHART 6.2

### MOTOR STALLS DURING ACCELERATION

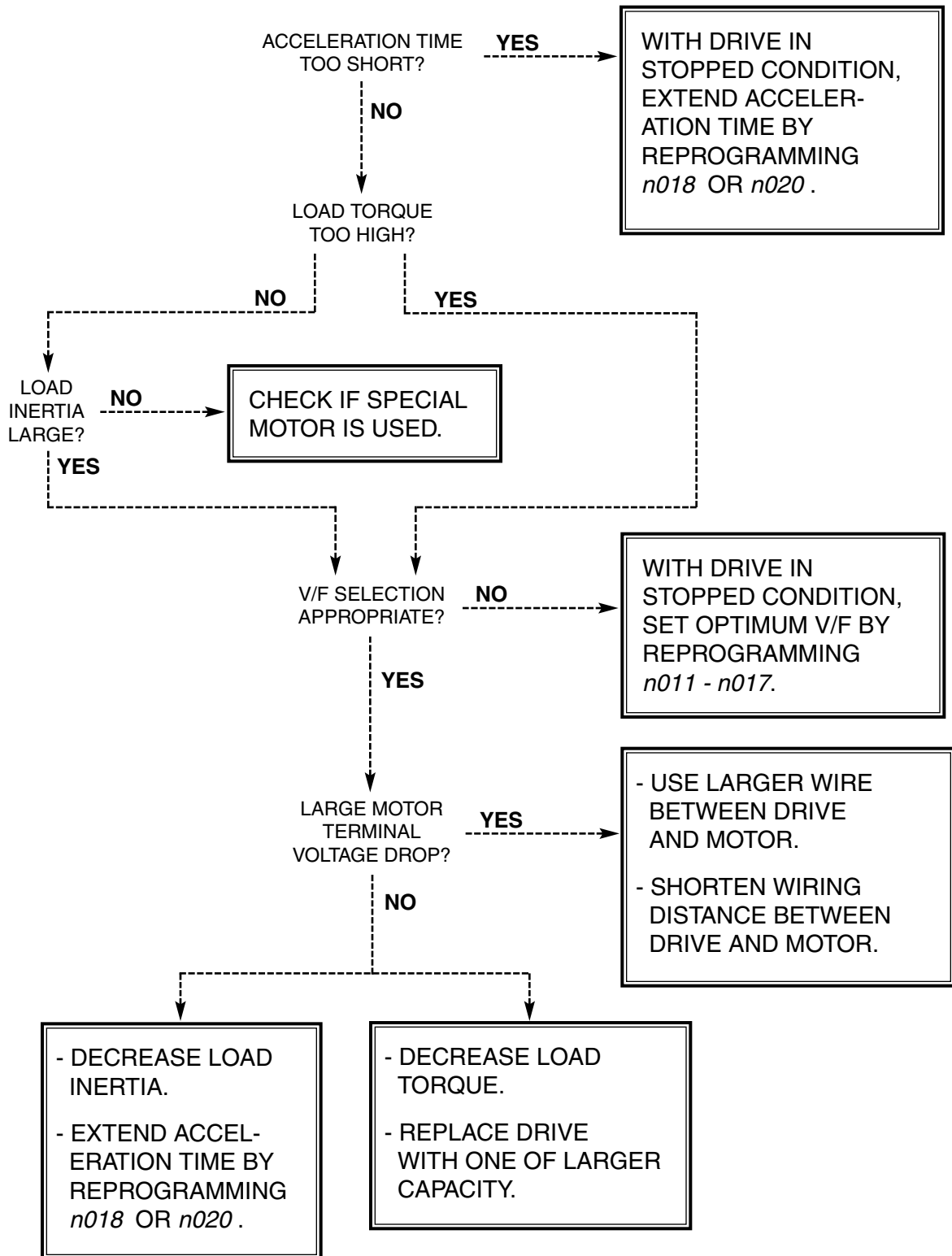

**TROUBLESHOOTING CHART 6.3**

**OVERVOLTAGE ( *ou* ) FAULT INDICATION**

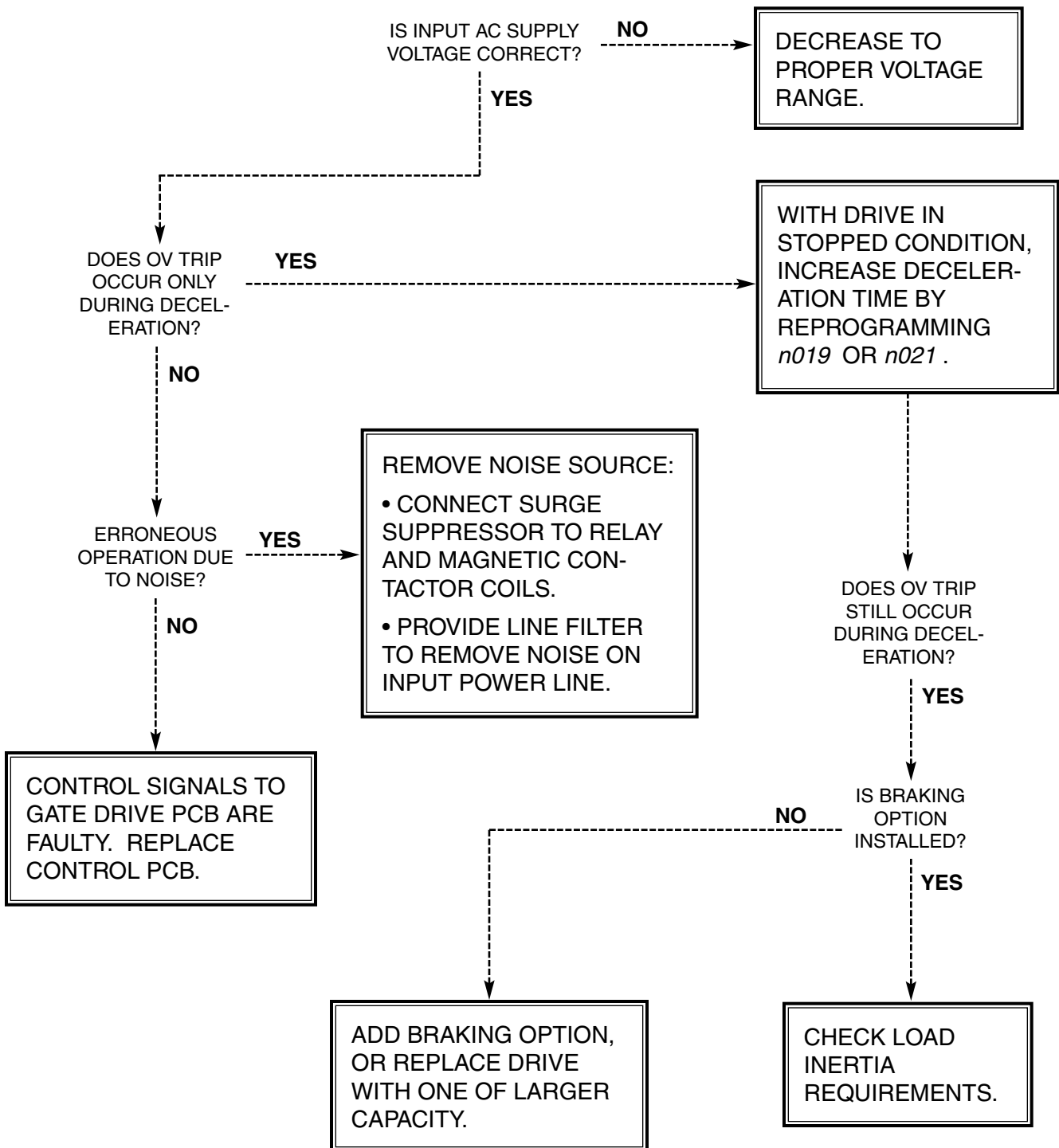

## TROUBLESHOOTING CHART 6.4

### BLOWN FUSE ( PUF ) FAULT INDICATION

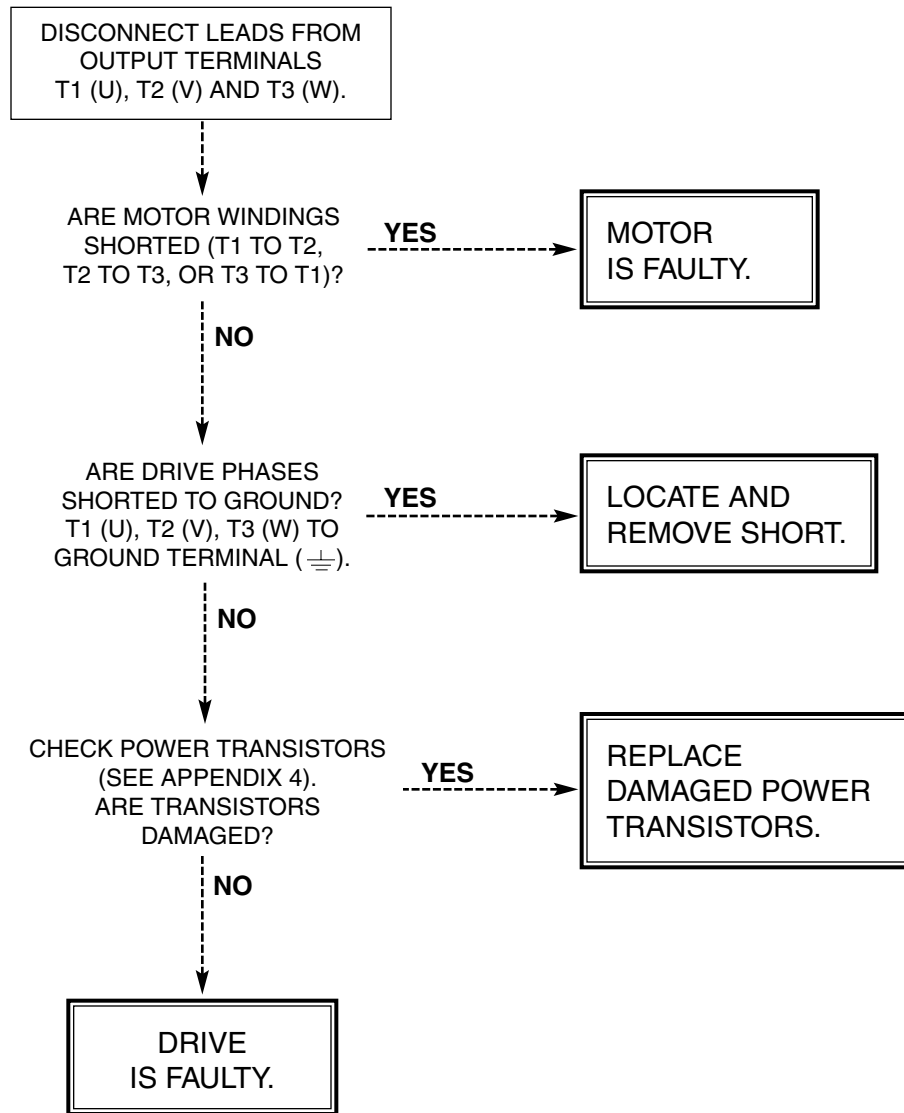

### CAUTION

Do not replace DC Bus fuse without first checking output transistors.

## TROUBLESHOOTING CHART 6.5

### OVERCURRENT (oC) FAULT INDICATION

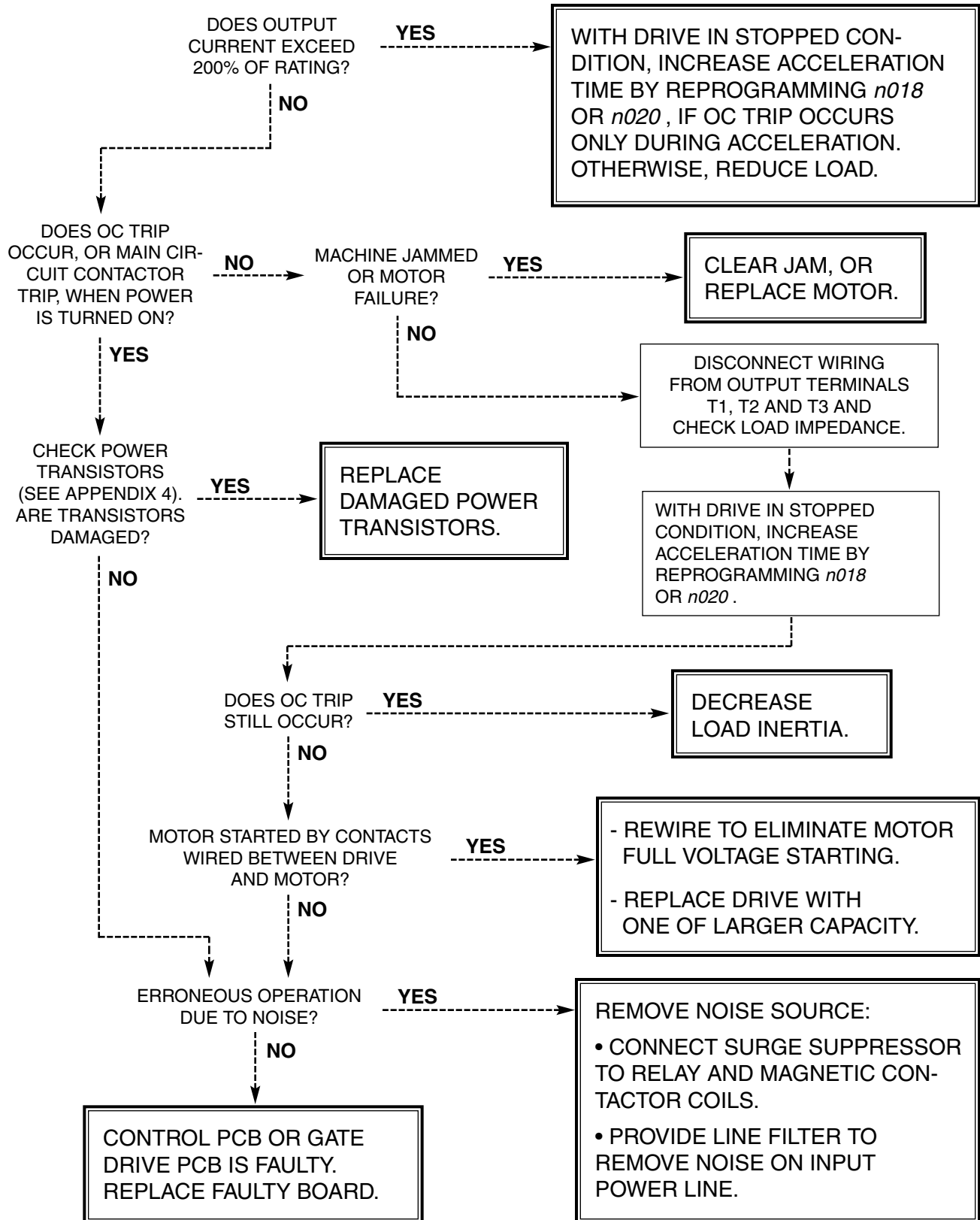



## TROUBLESHOOTING CHART 6.6

### OVERLOAD (oL) FAULT INDICATION

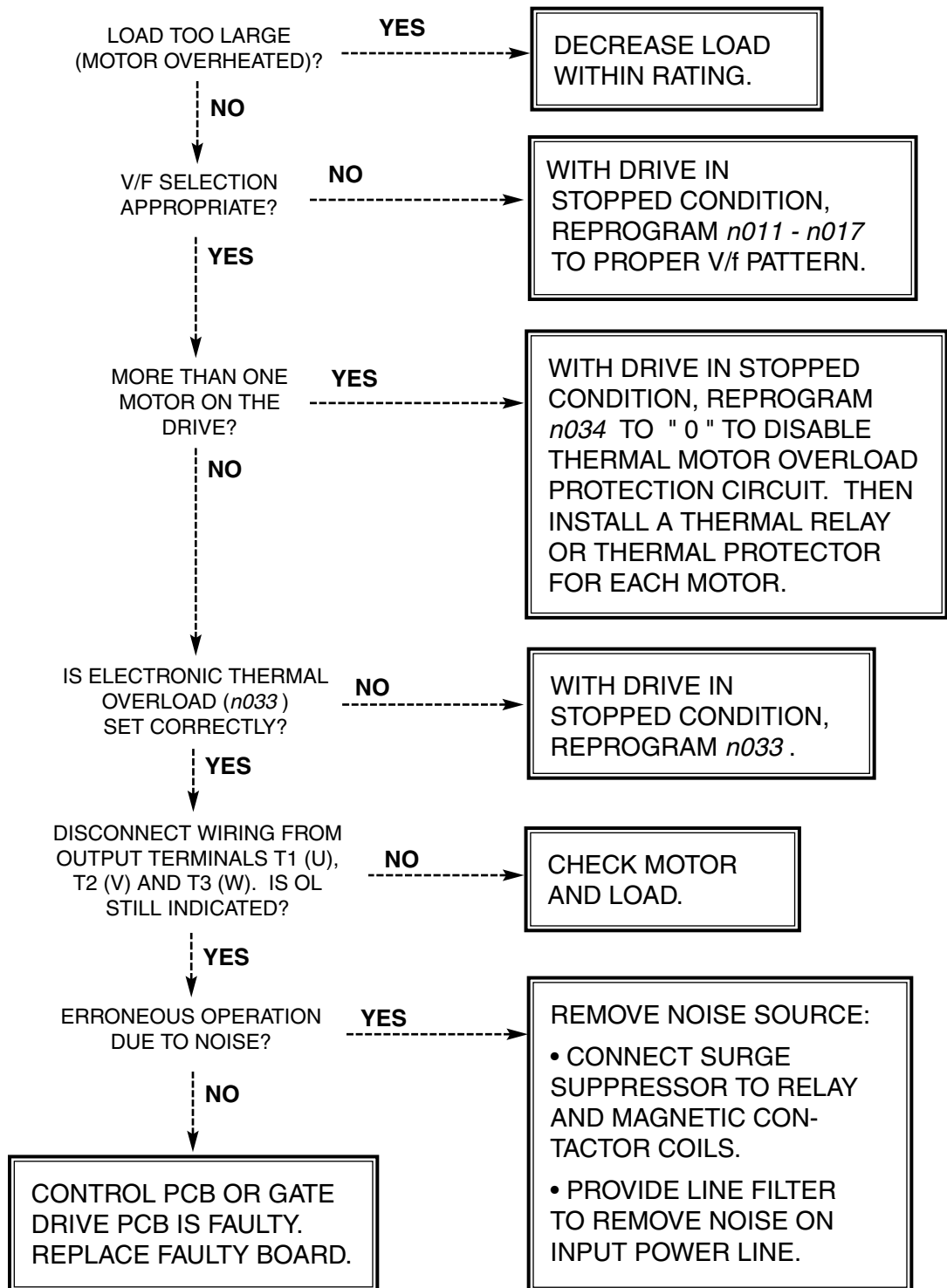

## TROUBLESHOOTING CHART 6.7

### UNDERVOLTAGE ( $U_u$ ) FAULT INDICATION

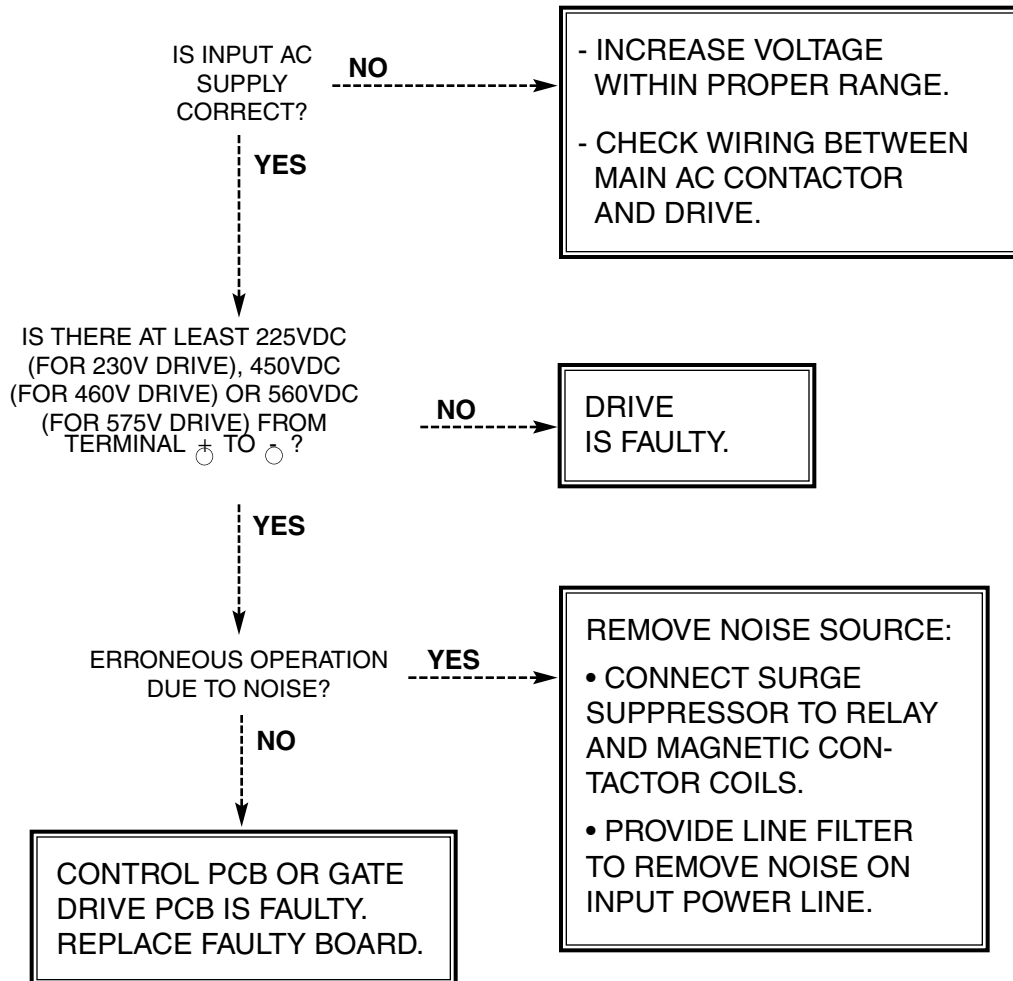

## TROUBLESHOOTING CHART 6.8

### CONTROL FUNCTION ERROR ( *CPF*\_ ) FAULT INDICATION

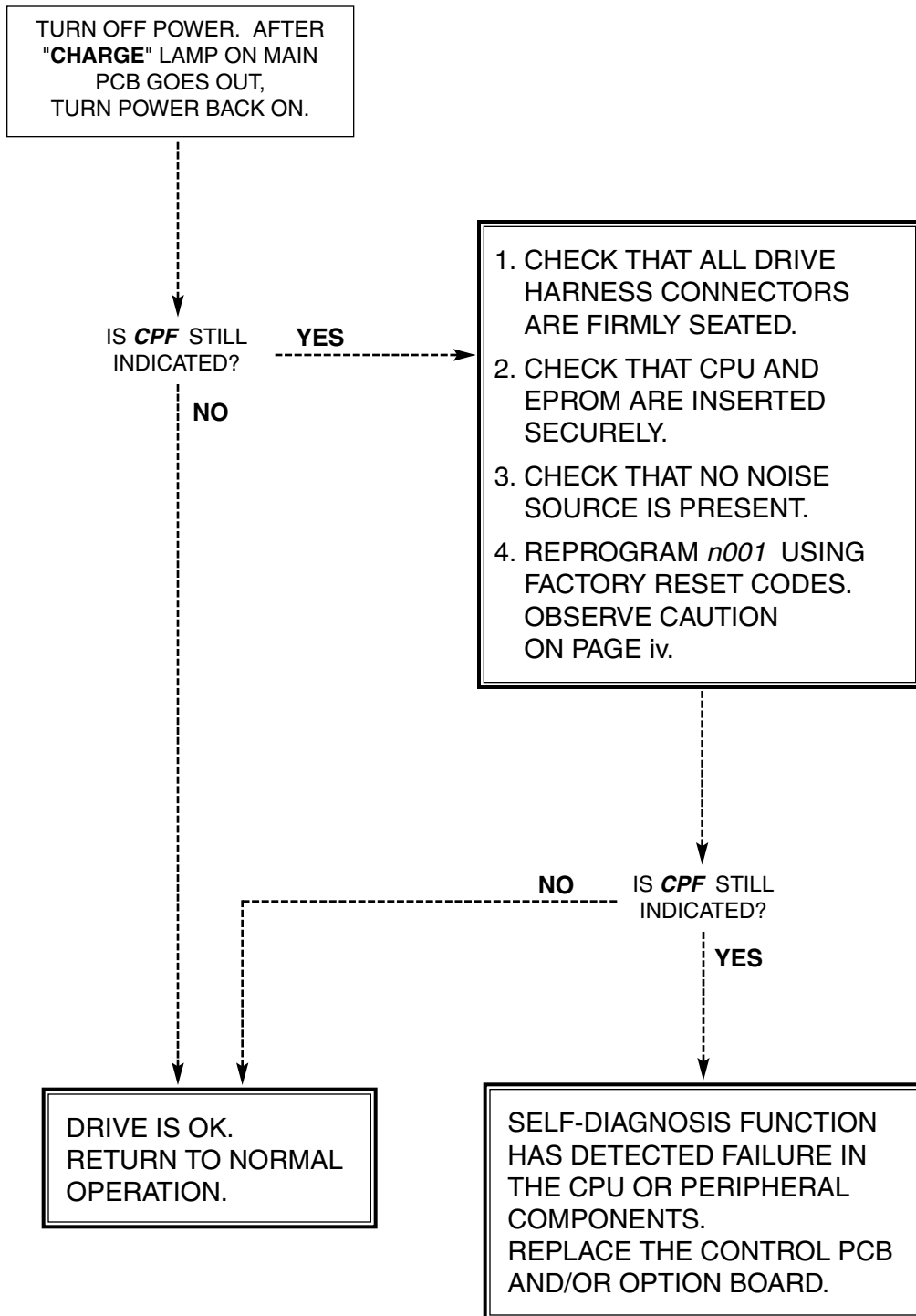

## TROUBLESHOOTING CHART 6.9

### EXTERNAL FAULT ( *EF\_* ) INDICATION

\*

IS AN EXTERNAL FAULT SIGNAL  
PRESENT (OPEN OR CLOSED \*\*  
CIRCUIT BETWEEN TERMINAL  
SC AND WHICHEVER TERMINAL  
(S2-S6) HAS BEEN PROGRAMMED  
FOR EXT. FAULT INPUT)?

YES

FAULT HAS OCCURRED  
IN CIRCUITS OUTSIDE  
THE DRIVE.  
TROUBLESHOOT AND  
CORRECT.

NO

CONTROL PCB IS  
FAULTY. REPLACE.

\* THIRD DIGIT OF FAULT DISPLAY  
INDICATES WHICH TERMINAL IS  
INVOLVED.

\*\* DEPENDING ON WHETHER THE  
TERMINAL HAS BEEN PROGRAMMED  
TO MONITOR A N.O. OR N.C.  
CONTACT.

**TROUBLESHOOTING CHART 6.10**

**NO DIGITAL OPERATOR DISPLAY**

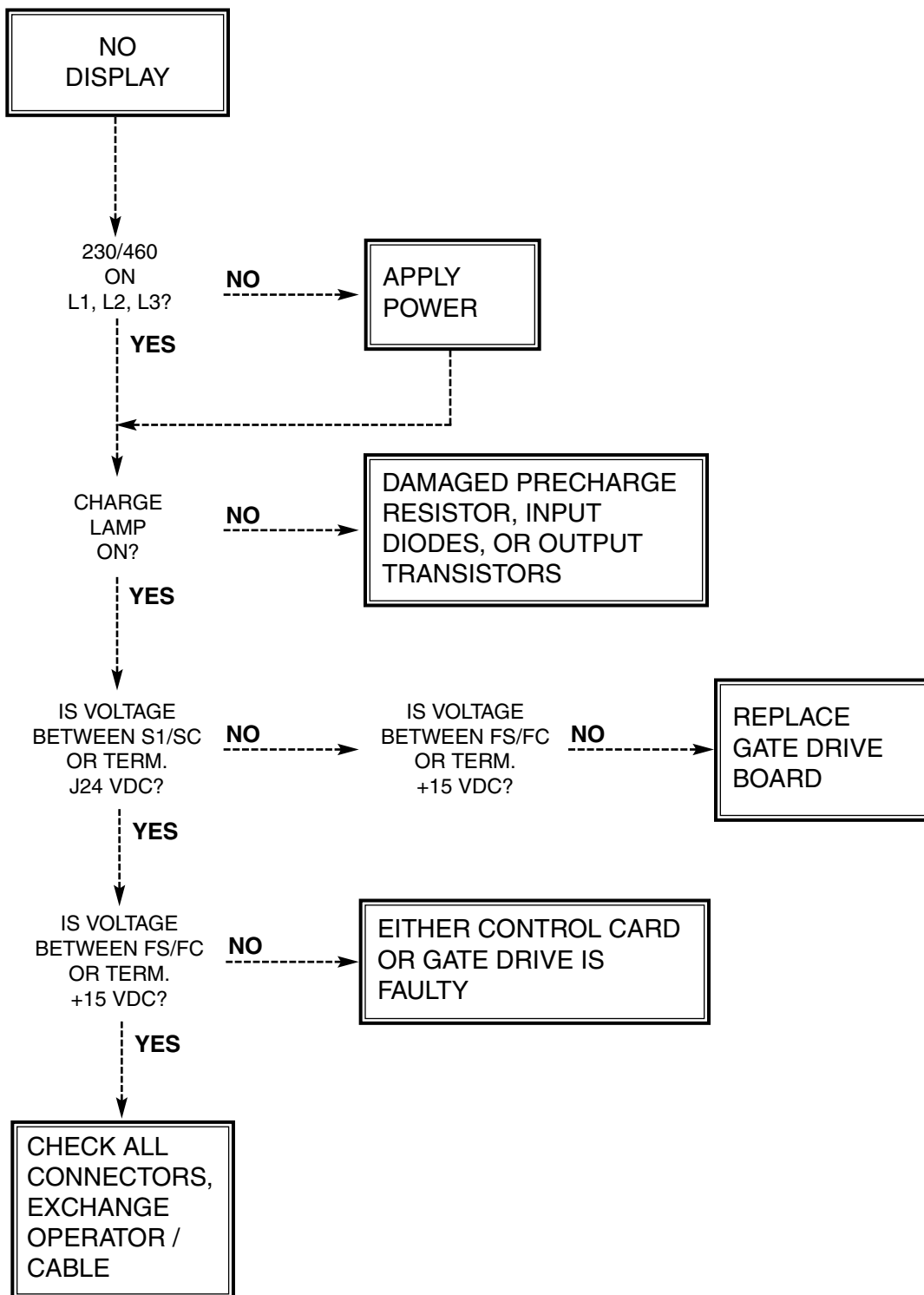

## 6.4 DIODE AND IGBT (TRANSISTOR) MODULE RESISTANCE TEST

### A. DIODE MODULE

Measure the resistance across the module terminals with a volt-ohm meter. Set the meter at the X1 range. The measured resistance should be within the values listed in Table 6-4.

NOTE: If the DC bus fuse is blown (PUF), the values shown below may not be accurate.

### WARNING

Power should be removed from L1, L2, & L3 and the CHARGE light should be out prior to conducting these tests.

Table 6-4. Diode Module Resistances

+	-	NORMAL READING (OHMS)	ABNORMAL READING (OHMS)	+	-	NORMAL READING (OHMS)	ABNORMAL READING (OHMS)
ON	ON			ON	ON		
L1	⊕1	2.5 to 50 Ω or 0.25 to 0.7 if using → scale	0 Ω or INFINITE	L1	⊖	INFINITE	LESS THAN 1M Ω
L2	⊕1			L2	⊖		
L3	⊕1			L3	⊖		
⊖	L1			⊕2	L1		
⊖	L2			⊕2	L2		
⊖	L3			⊕2	L3		
				⊕2	⊖	MAGNITUDE OF CAP CHARGE TO INFINITE	0 Ω or INFINITE

### RESISTANCE TEST FOR 3Ø CONVERTER MODULES (BRIDGE RECT)

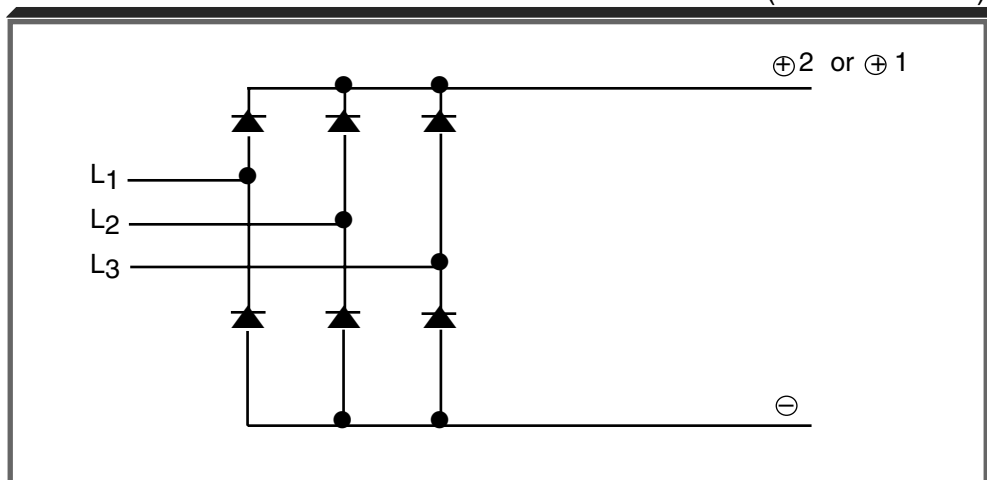

VOM RESISTANCE SCALE R x 1  
 + IS THE POSITIVE POLARITY LEAD \*  
 - IS THE NEGATIVE POLARITY LEAD

\* The VOM red lead is not necessarily the positive potential in the resistance mode. For these tests the + lead refers to the positive potential. Make sure you know which polarity you have on your VOM.

## B. TRANSISTOR MODULE

Measure the resistance across the module terminals with a volt-ohm meter. Set the meter to the X1 range. The measured resistance should be within the values listed in Table 6-5.

NOTE: If the DC bus fuse is blown (PUF), the values shown below may not be accurate.

**Table 6-5. Transistor Module Resistances**

+	-	NORMAL READING (OHMS)	ABNORMAL READING (OHMS)
ON	ON		
B1/⊕3/⊕1 B1/⊕3/⊕1 B1/⊕3/⊕1 T1/U T2/V T3/W	T1/U T2/V T3/W ⊖ ⊖ ⊖	INFINITE	0 Ω
T1/U T2/V T3/W ⊖ ⊖ ⊖	B1/⊕3/⊕1 B1/⊕3/⊕1 B1/⊕3/⊕1 T1 T2 T3	2.5 to 50 Ω or 0.3 to 0.7 if using scale	0 Ω or INFINITE

### RESISTANCE TEST FOR 3Ø TRANSISTOR MODULES

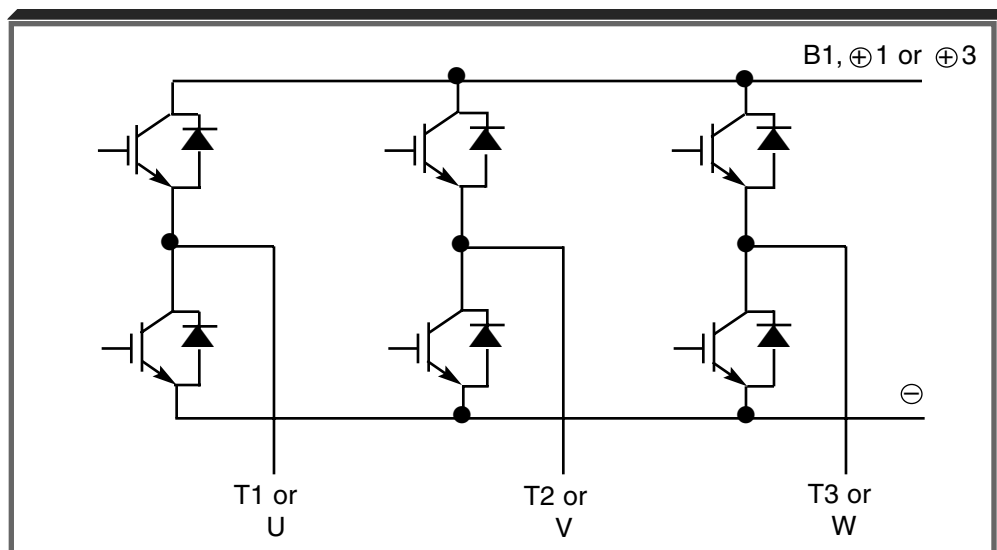

VOM RESISTANCE SCALE R x 1  
 + IS THE POSITIVE POLARITY LEAD \*  
 - IS THE NEGATIVE POLARITY LEAD

\* The VOM red lead is not necessarily the positive potential in the resistance mode. For these tests the + lead refers to the positive potential. Make sure you know which polarity you have on your VOM.

# Appendix 1. LISTING OF PARAMETERS

The GPD 506/P5 control circuits use various parameters to select functions and characteristics of the drive. Changing of parameter settings must be done in the Program mode, or by use of the Quick-Start Displays (see Section 4).

The following table lists all parameters in numerical order. For each parameter, reference paragraph(s) in Section 5 are listed (if applicable) where the features of the drive affected by that parameter are described.

**Table A1-1. Drive Parameters (nXXX)**

PARAM. NO.	FUNCTION NAME (ACTUAL DISPLAY)	DESCRIPTION	SETTING RANGE	FACTORY SETTING **	USER SETTING	PARA. REF.																																								
n001	Parameter Selection / Initialization  (Password)	0 : n001 can be read and set; n002 -n116 read only 1 : n001 -n035 read and set; n036 -n116 read only 2 : n001 -n053 read and set; n054 -n116 read only 3 : n001 -n116 read and set 4, 5, 6, 7 : Not Used 8 : 2-Wire initialization 9 : 3-Wire initialization	0 to 9	1		5.23																																								
n002	Operation Mode Selection  (Oper Mode Select)	<table border="0"> <tr> <td>LED Setting</td> <td>LCD Setting</td> <td>Sequence</td> <td>Reference</td> </tr> <tr> <td>0</td> <td>SEQ=OPR REF=OPR</td> <td>Dig. Oper.</td> <td>Dig. Oper.</td> </tr> <tr> <td>1</td> <td>SEQ=TRM REF=OPR</td> <td>Ext. Term.</td> <td>Dig. Oper.</td> </tr> <tr> <td>2</td> <td>SEQ=OPR REF=TRM</td> <td>Dig. Oper.</td> <td>Ext. Term.</td> </tr> <tr> <td>3</td> <td>SEQ=TRM REF=TRM**</td> <td>Ext. Term.</td> <td>Ext. Term.</td> </tr> <tr> <td>4</td> <td>SEQ=OPR REF=COM</td> <td>Dig. Oper.</td> <td>Dig. Oper.</td> </tr> <tr> <td>5</td> <td>SEQ=TRM REF=COM</td> <td>Ext. Term.</td> <td>Ser. Comm.</td> </tr> <tr> <td>6</td> <td>SEQ=COM REF=COM</td> <td>Ser. Comm.</td> <td>Ser. Comm.</td> </tr> <tr> <td>7</td> <td>SEQ=COM REF=OPR</td> <td>Ser. Comm.</td> <td>Dig. Oper.</td> </tr> <tr> <td>8</td> <td>SEQ=COM REF=TRM</td> <td>Ser. Comm.</td> <td>Ext. Term.</td> </tr> </table>	LED Setting	LCD Setting	Sequence	Reference	0	SEQ=OPR REF=OPR	Dig. Oper.	Dig. Oper.	1	SEQ=TRM REF=OPR	Ext. Term.	Dig. Oper.	2	SEQ=OPR REF=TRM	Dig. Oper.	Ext. Term.	3	SEQ=TRM REF=TRM**	Ext. Term.	Ext. Term.	4	SEQ=OPR REF=COM	Dig. Oper.	Dig. Oper.	5	SEQ=TRM REF=COM	Ext. Term.	Ser. Comm.	6	SEQ=COM REF=COM	Ser. Comm.	Ser. Comm.	7	SEQ=COM REF=OPR	Ser. Comm.	Dig. Oper.	8	SEQ=COM REF=TRM	Ser. Comm.	Ext. Term.	0 to 8	3		5.16B, 5.22B
LED Setting	LCD Setting	Sequence	Reference																																											
0	SEQ=OPR REF=OPR	Dig. Oper.	Dig. Oper.																																											
1	SEQ=TRM REF=OPR	Ext. Term.	Dig. Oper.																																											
2	SEQ=OPR REF=TRM	Dig. Oper.	Ext. Term.																																											
3	SEQ=TRM REF=TRM**	Ext. Term.	Ext. Term.																																											
4	SEQ=OPR REF=COM	Dig. Oper.	Dig. Oper.																																											
5	SEQ=TRM REF=COM	Ext. Term.	Ser. Comm.																																											
6	SEQ=COM REF=COM	Ser. Comm.	Ser. Comm.																																											
7	SEQ=COM REF=OPR	Ser. Comm.	Dig. Oper.																																											
8	SEQ=COM REF=TRM	Ser. Comm.	Ext. Term.																																											
n003	Motor Rated Voltage  (Input Voltage)	Nominal value of input power applied to drive	<table border="0"> <tr> <td>150.0 to 255.0 (230V drive)</td> <td>230.0 (VAC)</td> </tr> <tr> <td>150.0 to 510.0 (460V drive)</td> <td>460.0 (VAC)</td> </tr> <tr> <td>150.0 to 733.1 (600V drive)</td> <td>575.0 (VAC)</td> </tr> </table>	150.0 to 255.0 (230V drive)	230.0 (VAC)	150.0 to 510.0 (460V drive)	460.0 (VAC)	150.0 to 733.1 (600V drive)	575.0 (VAC)			5.28B																																		
150.0 to 255.0 (230V drive)	230.0 (VAC)																																													
150.0 to 510.0 (460V drive)	460.0 (VAC)																																													
150.0 to 733.1 (600V drive)	575.0 (VAC)																																													
n004	Stop Method  (Stopping Method)	<table border="0"> <tr> <td>LED Setting</td> <td>LCD Setting</td> </tr> <tr> <td>0</td> <td>Ramp to STOP **</td> </tr> <tr> <td>1</td> <td>Coast to STOP</td> </tr> <tr> <td>2</td> <td>Coast w/Timer 1</td> </tr> <tr> <td>3</td> <td>Coast w/Timer 2</td> </tr> </table>	LED Setting	LCD Setting	0	Ramp to STOP **	1	Coast to STOP	2	Coast w/Timer 1	3	Coast w/Timer 2	0 to 3	0		5.25																														
LED Setting	LCD Setting																																													
0	Ramp to STOP **																																													
1	Coast to STOP																																													
2	Coast w/Timer 1																																													
3	Coast w/Timer 2																																													
n005	Phase Rotation  (Motor Rotation)	<table border="0"> <tr> <td>LED Setting</td> <td>LCD Setting</td> </tr> <tr> <td>0</td> <td>Rotate C.C.W **</td> </tr> <tr> <td>1</td> <td>Rotate C.W. (or opposite direction)</td> </tr> </table>	LED Setting	LCD Setting	0	Rotate C.C.W **	1	Rotate C.W. (or opposite direction)	0 or 1	0																																				
LED Setting	LCD Setting																																													
0	Rotate C.C.W **																																													
1	Rotate C.W. (or opposite direction)																																													



**Table A1-1. Drive Parameters (nXXX) – Continued**

PARAM. NO.	FUNCTION NAME (ACTUAL DISPLAY)	DESCRIPTION		SETTING RANGE	FACTORY SETTING **	USER SETTING	PARA. REF.
<b>n006</b>	Reverse Prohibit <b>(Reverse Oper)</b>	LED Setting 0 1	LCD Setting <b>REV Allowed **</b> REVProhibited	0 or 1	0		
<b>n007</b>	<b>LOCAL/REMOTE</b> Key Function <b>(Local/Remote Key)</b>	LED Setting 0 1	LCD Setting Disabled <b>Enabled **</b>	0 or 1	1		
<b>n008</b>	<b>STOP KEY</b> Function <b>(Oper STOP Key)</b>	LED Setting 0 1	LCD Setting Disabled <b>Enabled **</b>	0 or 1	1		Description <b>STOP</b> key is effective only when sequence command (per <b>n002</b> ) is to be from Digital Operator <b>STOP</b> key is effective-regardless of programming of <b>n002</b>
<b>n009</b>	Frequency Reference Setting Method From Digital Operator <b>(Operator M.O.P.)</b>	LED Setting 0 1	LCD Setting Enter Not Used <b>Enter Key Used **</b>	0 or 1	1		Description <b>ENTER</b> key does not have to be pressed to write-in new value <b>ENTER</b> key must be pressed to write-in new value
<b>n010</b>	V/f Pattern Selection <b>(V/f Selection)</b> See Note 5	LED Setting 0 1	LCD Setting User Defined V/f <b>60 Hz Preset **</b>	0 or 1	1		Description Custom V/f pattern (60 Hz VT default) Preset V/f pattern 5.28
<b>n011</b>	Frequency – Max. <b>(Max Frequency)</b>	Maximum level for drive output frequency		50.0 to 400.0	60.0 (Hz) <b>See Note 1</b>		5.28
<b>n012</b>	Voltage – Max. <b>(Max Voltage)</b>	Maximum level of drive output voltage		0.1 to 255.0 (230V drive) 0.1 to 510.0 (460V drive) 0.1 to 733.1 (600V drive)	230.0 (VAC) <b>See Note 1</b> 460.0 (VAC) <b>See Note 1</b> 575.0 (VAC) <b>See Note 1</b>		5.28
<b>n013</b>	Frequency – Max. Voltage Point <b>(Base Frequency)</b>	Level of frequency at which drive output voltage will reach <b>n012</b> value		0.2 to 400.0	60.0 (Hz) <b>See Note 1</b>		5.28

**Table A1-1. Drive Parameters (nXXX) – Continued**

PARAM. NO.	FUNCTION NAME (ACTUAL DISPLAY)	DESCRIPTION	SETTING RANGE	FACTORY SETTING **	USER SETTING	PARA. REF.
<b>n014</b>	Frequency – Midpoint <b>(Mid Frequency)</b>	Level of frequency at which drive output voltage will reach <b>n015</b> value	0.1 to 399.9	3.0 (Hz) <b>See Note 1</b>		5.28
<b>n015</b>	Voltage – Midpoint <b>(Mid Voltage)</b>	Level of drive output voltage when output frequency is at <b>n014</b> value	0.1 to 255.0 (230V drive)	17.2 (VAC) <b>See Note 1</b>		5.28
			0.1 to 510.0 (460V drive)	34.5 (VAC) <b>See Note 1</b>		
			0.1 to 733.1 (600V drive)	143.8 (VAC) <b>See Note 1</b>		
<b>n016</b>	Frequency – Min. <b>(Min Frequency)</b>	Lowest level of output frequency drive will produce	0.1 to 10.0	1.5 (Hz) <b>See Note 1</b>		5.28
<b>n017</b>	Voltage – Min. <b>(Min Voltage)</b>	Level of drive output voltage output frequency is at <b>n016</b> value	0.1 to 50.0 (230V drive)	11.5 (VAC) <b>See Note 1</b>		5.28
			0.1 to 100.0 (460V drive)	23.0 (VAC) <b>See Note 1</b>		
			0.1 to 143.7 (600V drive)	25.8 (VAC) <b>See Note 1</b>		
<b>n018</b>	Acceleration Time 1 <b>(Accel Time 1)</b> <b>See Note 5</b>	Time for drive output to ramp from Fmin. to Fmax.  Setting increment is 0.1 sec. from 0.0 to 999.9 sec, and 1 sec. from 1000 to 3600 sec.	0.0 to 3600	10.0 (sec)		5.2
<b>n019</b>	Deceleration Time 1 <b>(Decel Time 1)</b> <b>See Note 5</b>	Time for drive output to ramp from Fmax. to Fmin.  Setting increment is 0.1 sec. from 0.0 to 999.9 sec, and 1 sec. from 1000 to 3600 sec.	0.0 to 3600	10.0 (sec)		5.2
<b>n020</b>	Acceleration Time 2 <b>(Accel Time 2)</b>	Alternate time for drive output to ramp from Fmin. to Fmax.	0 to 255	10 (sec)		5.2
<b>n021</b>	Deceleration Time 2 <b>(Decel Time 2)</b>	Alternate time for drive output to ramp from Fmax. to Fmin.	0 to 255	10 (sec)		5.2
<b>n022</b>	S-curve Selection <b>(S-Curve Select)</b>	LED Setting      LCD Setting 0                    No S-Curve 1 <b>0.2 Sec **</b> 2                    0.5 Sec 3                    1.0 Sec	0 to 3	1		5.3
<b>n023</b>	Digital Operator Display Mode <b>(Display Units)</b>	LED Setting      LCD Setting 0 <b>0 **</b> 1                    1 2-39                2-39 40-4999            40-4999	<u>Display Units</u> 0 to 4999	0	0.1 Hz 0.1 % rpm custom	5.8

**Table A1-1. Drive Parameters (nXXX) – Continued**

PARAM. NO.	FUNCTION NAME (ACTUAL DISPLAY)	DESCRIPTION	SETTING RANGE	FACTORY SETTING **	USER SETTING	PARA. REF.																		
<b>n024</b>	Frequency Reference 1 <b>(Reference 1)</b> See Note 5	Frequency set by Digital Operator (or value retained by Up/Down or Sample/Hold function)	0 to 400.0 <b>See Note 4</b>	0.0 (Hz)		5.19B																		
<b>n025</b>	Frequency Reference 2 <b>(Reference 2)</b>	Additional frequency setpoint for multi-step speed	0 to 400.0 <b>See Note 4</b>	0.0 (Hz)		5.19B																		
<b>n026</b>	Frequency Reference 3 <b>(Reference 3)</b>	Additional frequency setpoint for multi-step speed	0 to 400.0 <b>See Note 4</b>	0.0 (Hz)		5.19B																		
<b>n027</b>	Frequency Reference 4 <b>(Reference 4)</b>	Additional frequency setpoint for multi-step speed	0 to 400.0 <b>See Note 4</b>	0.0 (Hz)		5.19B																		
<b>n028</b>	Frequency Reference 5 <b>(Reference 5)</b>	Additional frequency setpoint for multi-step speed	0 to 400.0 <b>See Note 4</b>	0.0 (Hz)		5.19B																		
<b>n029</b>	Frequency Reference 6 <b>(Reference 6)</b>	Additional frequency setpoint for multi-step speed	0 to 400.0 <b>See Note 4</b>	0.0 (Hz)		5.19B																		
<b>n030</b>	Jog Reference <b>(Jog Reference)</b>	Operating frequency when a Jog command is input	0 to 400.0 <b>See Note 4</b>	6.0 (Hz)		5.15, 5.19B																		
<b>n031</b>	Frequency Reference Upper Limit <b>(Ref Upper Limit)</b>		0 to 109	100 (%)		5.12																		
<b>n032</b>	Frequency Reference Lower Limit <b>(Ref Lower Limit)</b>		0 to 100	0 (%)		5.12																		
<b>n033</b>	Motor Rated Current <b>(Motor Rated FLA)</b> See Note 5	FLA rating of motor	<b>See Note 2</b>	(A)  <b>See Note 3</b>		5.26																		
<b>n034</b>	Electronic Thermal Overload Protection <b>(Motor OL Sel)</b>	<table border="0"> <tr> <td>LED Setting</td> <td>LCD Setting</td> <td>Characteristics</td> </tr> <tr> <td>0</td> <td>Disabled</td> <td>No protection</td> </tr> <tr> <td>1</td> <td><b>STD Motor/8 min**</b></td> <td>Standard motor (8 min.)</td> </tr> <tr> <td>2</td> <td>STD Motor/5 min</td> <td>Standard motor (5 min.)</td> </tr> <tr> <td>3</td> <td>INV Motor/8 min</td> <td>Blower-cooled motor (8 min.)</td> </tr> <tr> <td>4</td> <td>INV Motor/5 min</td> <td>Blower-cooled motor (5 min.)</td> </tr> </table>	LED Setting	LCD Setting	Characteristics	0	Disabled	No protection	1	<b>STD Motor/8 min**</b>	Standard motor (8 min.)	2	STD Motor/5 min	Standard motor (5 min.)	3	INV Motor/8 min	Blower-cooled motor (8 min.)	4	INV Motor/5 min	Blower-cooled motor (5 min.)	0 to 4	1		5.26
LED Setting	LCD Setting	Characteristics																						
0	Disabled	No protection																						
1	<b>STD Motor/8 min**</b>	Standard motor (8 min.)																						
2	STD Motor/5 min	Standard motor (5 min.)																						
3	INV Motor/8 min	Blower-cooled motor (8 min.)																						
4	INV Motor/5 min	Blower-cooled motor (5 min.)																						

**Table A1-1. Drive Parameters (nXXX) – Continued**

PARAM. NO.	FUNCTION NAME (ACTUAL DISPLAY)	DESCRIPTION		SETTING RANGE	FACTORY SETTING **	USER SETTING	PARA. REF.	
<b>n035</b>	Overheat Stop Method  <b>(OH1 Stop Method)</b>	LED Setting	LCD Setting	0 to 3	3			
		0	Ramp STOP/Decel1					Stop method Ramp to stop – Decel 1 (fault)
		1	Coast to STOP					Coast to stop (fault)
		2	Ramp STOP/Decel1					Ramp to stop – Decel 2 (fault)
3	<b>Continue Oper**</b>	Continue operation (alarm) at 80% & Freq. Ref.						
<b>n036</b>	Multi-function Input Selection  <b>(Terminal S2 Sel)</b>	LED Setting	LCD Setting	0 to 28	0		5.19	
		0	<b>Reverse RUN (2W)**</b>					Reverse run (2-Wire sequence) [ can only be set in n036 ]
<b>n037</b>	Multi-function Input Selection [ When <b>n036</b> has been set to " 1 ", this parameter will display "In Use by Other", and no value can be entered]  <b>(Terminal S3 Sel)</b>	1	FWD/REV Cmd (3W)	Fwd / Rev command (3-Wire sequence) [ can only be set in n036 ]	2 to 28	2 (--)*	5.19	
		2	<b>Ext Fault (NO) **</b>	External fault (N.O.)				
		3	Ext Fault (NC)	External fault (N.C.)				
		4	<b>Fault Reset **</b>	Fault reset				
		5	LOCAL/REMOTE Sel	Remote / Local selection				
		6	COM/INV Sel	Serial communication/Dig.Op. (Freq. Ref. & Run command)				
		7	STOP Cmd/Dec2 NO	Stop command using Decel. Time 2 (Normally Open)				
		8	STOP Cmd/Dec2 NC	Stop command using Decel. Time 2 (Normally Closed)				
		9	Master FREF Sel	Auto frequency reference selection				
<b>n038</b>	Multi-function Input Selection  <b>(Terminal S4 Sel)</b>	<b>10</b>	<b>Multi-Step Spd1**</b>	Multi-step speed reference Command 1	2 to 28	4	5.19	
		<b>11</b>	<b>Multi-Step Spd2**</b>	Multi-step speed reference Command 2				
		12	Multi-Step Spd3	Multi-step speed reference Command 3				
<b>n039</b>	Multi-function Input Selection [ When <b>n040</b> has been set to " 29 ", this parameter will display " In Use by Other" and no value can be entered]  <b>(Terminal S5 Sel)</b>	13	JOG Command	Jog command	2 to 28	10	5.19	
		14	ACC/DEC Switch	Accel/Decel time change command				
		15	Ext Baseblk (NO)	External base block (N.O.)				
		16	Ext Baseblk (NC)	External base block (N.C.)				
		17	SpdSrch (MAXFRQ)	Speed search from maximum frequency				
		18	SpdSrch (SETFRQ)	Speed search from set frequency				
		19	Param Lockout	Parameter change enable				
		20	PID I Reset	I value reset (PID)				
		21	PID Disable	PID control of				

**Table A1-1. Drive Parameters (nXXX) – Continued**

PARAM. NO.	FUNCTION NAME (ACTUAL DISPLAY)	DESCRIPTION				SETTING RANGE	FACTORY SETTING **	USER SETTING	PARA. REF.
<b>n040</b>	Multi-function Input Selection (Terminal S6 Sel)	22	Timer Start Cmd	Timer function	2 to 29	11		5.19	
		23	OH3 Input	OH3 (pre-alarm input)					
		24	Ref Sample Hold	Analog reference Sample/Hold command					
		25	KEB Cmd (NO)	Inertia ridethrough command (N.O.)					
		26	KEB Cmd (NC)	Inertia ridethrough command (N.C.)					
		27	Hold Command	Accel / Decel Ramp Hold					
		28	PID Polarity Sel	PID changeover					
		29	Up/Down Control	Up/Down Command [ can only be set in n040 ]					
<b>n041</b>	Multi-function Output (Terminals MA-MB-MC) (Terminal MA Sel)	LED Setting	LCD Setting	Description	0 to 17	0		5.20	
		0	<b>Fault **</b>	Fault					
		1	During Running	During running					
		2	At Speed	Speed agree					
		3	At Desired Speed	Desired speed agree					
		4	Freq Detection 1	Frequency detection 1					
		5	Freq Detection 2	Frequency detection 2					
		6	OverTrq De (NO)	Overtorque / undertorque detection (N.O.)					
		7	OverTrq Det (NC)	Overtorque / undertorque detection (N.C.)					
<b>n042</b>	Multi-function Output (Terminals M1-M2) (Terminal M1 Sel)	8	BaseBlocked	During base block	0 to 17	1		5.20	
		9	Operation mode	Operation mode					
		10	Ready	Ready					
		11	Timer Output	Timer function					
		12	Auto Restarting	During auto restart					
		13	OL Pre-Alarm	OL pre-alarm (80% of OL1 or OL2)					
		14	Freq Ref Loss	Frequency reference loss					
		15	Set By COM Cntl	Closed by serial comm.					
16	PID Fdbk Loss	PID feedback loss							
17	OH1 Alarm	OH1 alarm (functions only if <b>n035</b> has been set to " 3 ")							
<b>n043</b>	Analog Input Selection (AnalogInput Sel)	LED Setting	LCD Setting	FV	FI	Auto/Man Switch	0 to 4	0	5.11, 5.22B
		0	<b>FV=MSTR FI=AUX**</b>	Auto	Man	Yes			
		1	FV=AUX FI=MSTR	Man	Auto	Yes			
		2	FV=RST FI=MSTR	Fit Rst	Auto	No			
		3	FV=MSTR FI=SQRT	Auto	$\sqrt{N}$	No			
4	FV=RST FI=SQRT	Fit Rst	$\sqrt{N}$	No					
<b>n044</b>	Terminal FI Signal Level Selection (Terminal FI Sel)	LED Setting	LCD Setting	Description	0 or 1	1		5.11, 5.22B	
		0	0-10 VDC	0-10V input (jumper J1 on Control PCB must be cut)					
		1	<b>4-20 mA**</b>	4-20mA input					

**Table A1-1. Drive Parameters (nXXX) – Continued**

PARAM. NO.	FUNCTION NAME (ACTUAL DISPLAY)	DESCRIPTION		SETTING RANGE	FACTORY SETTING **	USER SETTING	PARA. REF.	
n045	Frequency Reference Retention  <b>(MOP Ref Memory)</b>	LED Setting	LCD Setting	0 or 1	0		5.14	
		0	<b>Memorize FREF**</b>					Retained in Frequency Reference 1 ( <b>n024</b> ) (for Up/Down, Sample/ Hold functions)
n046	Frequency Reference Loss Detection <b>(Ref Loss Detect)</b>	LED Setting	LCD Setting	0 or 1	0		5.13	
		0	<b>Not Detected **</b>					No detection
n047	Freq. Ref. Level at loss of Freq. detection <b>(Fref Lvl@F Loss)</b>	1	Not Memorized					
		1	RUN @ no47 Fref					Continue to run at value set in <b>n047</b>
n048	Terminal FV Gain <b>(Terminal FV Gain)</b> See Note 5			0 to 200	100 (%)		5.10	
n049	Terminal FV Bias <b>(Terminal FV Bias)</b> See Note 5			-100 to 100	0 (%)		5.10	
n050	Terminal FI Gain <b>(Terminal FI Gain)</b>			0 to 200	100 (%)		5.10	
n051	Terminal FI Bias <b>(Terminal FI Bias)</b>			-100 to 100	0 (%)		5.10	
n052	Multi-function Analog Output  <b>(Terminal AM Sel)</b>	LED Setting	LCD Setting	0 to 3	0		5.18	
		0	<b>Output Freq **</b>					Output frequency (Hz)
		1	Output Amps					Output current (A)
		2	Output kWatts					Output power (kW)
3	DC Bus Voltage	DC bus voltage (VDC)						
n053	Analog Monitor Gain <b>(Terminal AM Gain)</b>			0.01 to 2.00	1.00		5.18	

**Table A1-1. Drive Parameters (nXXX) – Continued**

PARAM. NO.	FUNCTION NAME (ACTUAL DISPLAY)	DESCRIPTION		SETTING RANGE	FACTORY SETTING **	USER SETTING	PARA. REF.
<b>n054</b>	Carrier Frequency <b>(Carrier Freq Sel)</b>	LED <u>Setting</u>	LCD <u>Setting</u>	1 to 9	<b>See Note 3</b> 1 (x2.5 khz)		5.5 2.5 kHz
		2 (x2.5 khz)	5.0 kHz				
		3 (x2.5 khz)	8.0 kHz				
		4 (x2.5 khz)	10.0 kHz				
		5 (x2.5 khz)	12.5 kHz				
		6 (x2.5 khz)	15.0 kHz				
		7	Synchronous 1				
		8	Synchronous 2				
		9	Synchronous 3				
		10	7.0 kHz <sup>(6)</sup>				
<b>n055</b>	Momentary Power Loss Ride-through Method <b>(PwrL Selection)</b>	LED <u>Setting</u>	LCD <u>Setting</u>	0 to 2	0		5.17
		0	<b>Not Provided **</b>				
		1	2 Seconds Max				
		2	CPU Power Active				
			<u>Description</u>				
			Not provided				
			Continuous operation after power recovery within 2 sec.				
			Continuous operation after power recovery within control logic time (no fault output)				
<b>n056</b>	Speed Search Operation Level <b>(SpdSrch Current)</b>			0 to 200	110 (%)		5.19E
<b>n057</b>	Minimum Base Block Time <b>(Min Baseblock t)</b>			0.5 to 5.0	(Sec) <b>See Note 3</b>		5.19E
<b>n058</b>	V/f Reduction Level During Speed Search <b>(SpdSrch V/F)</b>			0 to 100	(%) <b>See Note 3</b>		5.19E
<b>n059</b>	Momentary Power Loss Ride-through Time <b>(PwrL Ridethru t)</b>			0.0 to 2.0	(Sec) <b>See Note 3</b>		5.17
<b>n060</b>	Number of Automatic Restart Attempts <b>(Num of Restarts)</b>			0 to 10	0		5.4

**Table A1-1. Drive Parameters (nXXX) – Continued**

PARAM. NO.	FUNCTION NAME (ACTUAL DISPLAY)	DESCRIPTION		SETTING RANGE	FACTORY SETTING **	USER SETTING	PARA. REF.	
<b>n061</b>	Fault Contact Selection at Automatic Restart  <b>(Restart Sel)</b>	LED Setting	LCD Setting	0 or 1	0		5.4	
		0	<b>Activate Flt Rly**</b>					Closed during auto restart
		1	No Rly Output					Open during auto restart
<b>n062</b>	Prohibit Frequency 1 <b>(Jump Freq 1)</b>			0.0 to 400.0	0.0 (Hz)		5.6	
<b>n063</b>	Prohibit Frequency 2 <b>(Jump Freq 2)</b>			0.0 to 400.0	0.0 (Hz)		5.6	
<b>n064</b>	Prohibit Frequency Deadband <b>(Jump Bandwidth)</b>			0.0 to 25.5	1.0 (Hz)		5.6	
<b>n065</b>	Elapsed Timer Selection  <b>(Elapsed Timer)</b>	LED Setting	LCD Setting	0 or 1	1			
		0	Time Power is ON					Accumulated time during power on
		1	<b>Time Running Mtr**</b>					Accumulated time during running
<b>n066</b>	Elapsed Timer 1 <b>(Elapsed Time 1)</b>		Used to set an initial value into the elapsed time meter.	0 to 9999	0 (Hours)			
<b>n067</b>	Elapsed Timer 2 <b>(Elapsed Time 2)</b>		Used to set an initial value into the elapsed time meter. hours)	0 to 27 (x 10,000)	0			
<b>n068</b>	DC Injection Current <b>(DCInj Current)</b>			0 to 100 [100% = drive rated current]	50 (%)		5.7	
<b>n069</b>	DC Injection Time at Stop <b>(DCInj Time@ Stop)</b>			0.0 to 10.0	0.0 (Sec)		5.7	
<b>n070</b>	DC Injection Time at Start <b>(DCInj Time@ Start)</b>			0.0 to 10.0	0.0 (Sec)		5.7	



**Table A1-1. Drive Parameters (nXXX) – Continued**

PARAM. NO.	FUNCTION NAME (ACTUAL DISPLAY)	DESCRIPTION	SETTING RANGE	FACTORY SETTING **	USER SETTING	PARA. REF.
n071	Torque Compensation Gain <b>(Torq Comp Gain)</b>		0.0 to 3.0	1.0		5.27
n072	Stall Prevention During Deceleration <b>(StallP Decel Sel)</b>	LED Setting 0 Disabled 1 <b>Enabled **</b>	0 or 1	1		5.24
n073	Stall Prevention Level During Acceleration <b>(StallP Accel Lvl)</b>	[ When level is set to 200%, stall prevention during acceleration is disabled ]	30 to 200	(%) <b>See Note 3</b>		5.24
n074	Stall Prevention Level at Set Frequency <b>(StallP Run Level)</b>	[ When level is set to 200%, stall prevention during running is disabled ]	30 to 200	(%) <b>See Note 3</b>		5.24
n075	Speed Coincidence Frequency <b>(Freq Det Level)</b>		0.0 to 400.0	0.0 (Hz)		5.20
n076	Frequency Agreed Detection Width <b>(Freq Det Width)</b>		0.0 to 25.5	2.0 (Hz)		5.20

**Table A1-1. Drive Parameters (nXXX) – Continued**

PARAM. NO.	FUNCTION NAME (ACTUAL DISPLAY)	DESCRIPTION			SETTING RANGE	FACTORY SETTING **	USER SETTING	PARA. REF.
<b>n077</b>	Overtorque / Undertorque Detection (OL3)  <b>(Torq Det Sel)</b>	LED	LCD		0 to 8	0		5.21
		<u>Setting</u>	<u>Setting</u>	<u>Method</u>				
		0	<b>Disabled **</b>	Detection disabled				
		1	OT/SpdAgree/Alm	Overtorque detect only at set frequency; operation continues				
		2	OT/RUN/Alm	Overtorque detect during all frequency conditions; operation continues				
		3	OT/SpdAgree/Flt	Overtorque detect only at set frequency; coast to stop				
		4	OT/RUN/Flt	Overtorque detect during all frequency conditions; coast to stop				
		5	UT/SpdAgree/Alm	Undertorque detect only at set frequency; operation continues				
		6	UT/RUN/Alm	Undertorque detect during all frequency conditions; operation continues				
7	UT/SpdAgree/Flt	Undertorque detect only at set frequency; coast to stop						
8	UT/RUN/Flt	Undertorque detect during all frequency conditions; coast to stop						
<b>n078</b>	Overtorque / Undertorque Detection Level  <b>(Torq Det Level)</b>				30 to 200 [100% = drive rated current ]	160 (%)		5.21
<b>n079</b>	Overtorque / Undertorque Detection Delay Time <b>(Torq Det Time)</b>				0.0 to 10.0	0.1 (Sec)		5.21
<b>n080</b>	On-delay Timer <b>(On-Delay Timer)</b>				0.0 to 25.5	0.0 (Sec)		5.19F
<b>n081</b>	Off-delay Timer <b>(Off-Delay Timer)</b>				0.0 to 25.5	0.0 (Sec)		5.19F

**Table A1-1. Drive Parameters (nXXX) – Continued**

PARAM. NO.	FUNCTION NAME (ACTUAL DISPLAY)	DESCRIPTION		SETTING RANGE	FACTORY SETTING **	USER SETTING	PARA. REF.	
<b>n082</b>	DB Resistor Overheat Function (rH)	LED Setting	LCD Setting	0 or 1	0			
	<b>(DB Resistor Prot)</b>	0	<b>Disabled **</b>					No DB protection calculated or provided
		1	Enabled					
<b>n083</b>	Input Phase Loss Detection Level (SPi) <b>(In Ph Loss Lvl)</b>		When set to 100%, input phase loss detection is disabled	1 to 100	7 (%)		5.29	
<b>n084</b>	PID Selection <b>(PID Mode)</b>	LED Setting	LCD Setting	0 to 3	0		5.22A	
	<b>See Note 5</b>	0	<b>Disabled **</b>					PID disabled
		1	Enabled D=Fdbk					PID enabled
		2	Enabled D=Fdfwd					PI with Feed Forward
		3	Enabled RevFdbk	Inverted PID				
<b>n085</b>	Feedback Calibration Gain <b>(PID Fdbk Gain)</b>			0.00 to 10.00	1.00		5.22E	
<b>n086</b>	Proportional Gain <b>(PID P Gain)</b>			0.0 to 10.0	1.0		5.22G	
<b>n087</b>	Integral Gain <b>(PID I Time)</b>			0.0 to 100.0	10.0 (Sec)		5.22G	
<b>n088</b>	Derivative Time <b>(PID D Time)</b>			0.00 to 1.00	0.00 (Sec)		5.22G	
<b>n089</b>	Limit of Integral Value <b>(PID I Limit)</b>			0 to 109	100 (%)		5.22H	
<b>n090</b>	Feedback Loss Detection <b>(PID FdbkLoss Sel)</b>	LED Setting	LCD Setting	0 or 1	0		5.22F	
		0	<b>Disabled **</b>					Detection is disabled
		1	MF Output Only					Detection is enabled - alarm only
		2	Fault output	Detection is enabled - fault				
<b>n091</b>	Feedback Loss Det. Level <b>(PID FdbkLoss Lvl)</b>			0 to 100	0 (%)		5.22F	

**Table A1-1. Drive Parameters (nXXX) – Continued**

PARAM. NO.	FUNCTION NAME (ACTUAL DISPLAY)	DESCRIPTION	SETTING RANGE	FACTORY SETTING **	USER SETTING	PARA. REF.
<b>n092</b>	Feedback Loss Det. Delay Time <b>(PID FdbkLoss Time)</b>		0.0 to 25.5	1.0 (Sec)		5.22F
<b>n093</b>	PID Output Selection <b>(PID Output Sel)</b>	LED Setting 0: <b>Not Inverted **</b> 1: Inverted	0 or 1	0		
<b>n094</b>	Sleep function Start Level <b>(Sleep Start Lvl)</b>		0.00 to 400.0	0.0 (Hz)		5.22I
<b>n095</b>	Sleep function Delay Function <b>(Sleep Delay Time)</b>		0.0 to 25.5	0.0 (Sec)		5.22I
<b>n096</b>	Energy Saving Selection <b>(Energy Save Sel)</b> <b>See Note 5</b>	LED Setting 0 <b>Disabled **</b> 1 Enabled	0 or 1	0		5.9
<b>n097</b>	Energy Saving Gain K2 <b>(Energy Save Gain)</b>		0.00 to 655.0	<b>See Note 3</b>		5.9
<b>n098</b>	Energy Saving Voltage Lower Limit at 60 Hz <b>(EngSavVLLmt @60Hz)</b>		0 to 120	75 (%)		5.9
<b>n099</b>	Energy Saving Voltage Lower Limit at 6 Hz <b>(EngSavVLLmt @ 6Hz)</b>		0 to 25	12 (%)		5.9
<b>n100</b>	Time of Average kW <b>(EngSavTime/ AvgkW)</b>		1 to 200 (x 25ms)	1 (= 25ms)		5.9
<b>n101</b>	Modbus Time Out Detection <b>(MODBUS Timeout)</b>	LED Setting 0 Disabled 1 <b>Enabled **</b>	0 or 1	1		5.16

**Table A1-1. Drive Parameters (nXXX) – Continued**

PARAM. NO.	FUNCTION NAME (ACTUAL DISPLAY)	DESCRIPTION		SETTING RANGE	FACTORY SETTING **	USER SETTING	PARA. REF.	
<b>n102</b>	Stop Method on Modbus Communication Error (CE)  <b>(MODBUS FaultStop)</b>	LED	LCD	0 to 3	1		5.16	
		<u>Setting</u>	<u>Setting</u>					<u>Stop method</u>
		0	Ramp STOP/Decel1 (fault)					Ramp to stop – Decel 1 (fault)
		1	<b>Coast to STOP**</b>					Coast to stop (fault)
		2	Ramp STOP/Decel2					Ramp to stop – Decel 2 (fault)
3	Continue Oper	Continue operation (alarm)						
<b>n103</b>	Modbus Setting Frequency Reference Unit <b>(MODBUS Fref Unit)</b>	LED	LCD	0 to 3	0		5.16	
		<u>Setting</u>	<u>Setting</u>					<u>Stop method</u>
		0	<b>1 = 0.1Hz **</b>					0.1 Hz / 1
		1	1 = 0.01Hz					0.01 Hz / 1
		2	30000 = 100%					100% / 30000
3	1 = 0.1%	0.01 % / 1						
<b>n104</b>	Modbus Slave Address <b>(MODBUS Address)</b>			0 to 31	1		5.16	
<b>n105</b>	Modus BPS Selection  <b>(MODBUS Baud Rate)</b>	LED	LCD	0 to 2	2		5.16	
		<u>Setting</u>	<u>Setting</u>					
		0	2400 Baud					
		1	4800 Baud					
2	<b>9600 Baud **</b>							
<b>n106</b>	Modbus Parity Selection  <b>(MODBUS Parity)</b>	LED	LCD	0 to 2	0		5.16	
		<u>Setting</u>	<u>Setting</u>					
		0	<b>No parity **</b>					
		1	Even parity					
2	Odd parity							
<b>n107</b>	Slip Compensation Gain <b>(Slip Comp Gain)</b>			0.0 to 9.9	0.0 (%)		5.23.1	
<b>n108</b>	Motor No-load Current <b>(Mtr No-Load Amp)</b>			0 to 99	30 (%)		5.23.1	
<b>n109</b>	Slip Comp. Primary Delay Time Constant <b>(Slip Comp Delay)</b>			0.0 to 25.5	2.0 (Sec)		5.23.1	

**Table A1-1. Drive Parameters (nXXX) – Continued**

PARAM. NO.	FUNCTION NAME (ACTUAL DISPLAY)	DESCRIPTION		SETTING RANGE	FACTORY SETTING **	USER SETTING	PARA. REF.
<b>n110</b>	Operator Connection	LED Setting	LCD Setting	0 or 1	0		5.16.1
	Fault Detection Selection	0	<b>Disabled **</b>				
<b>(Oper Detect Fit)</b>		1	Enabled				
<b>n111</b>	Local/Remote Changeover	LED Setting	LCD Setting	0 or 1	0		5.15.1
	Fault Detection Selection	0	<b>Cycle Extern RUN**</b>				
<b>(LOC/REM Change)</b>		1	Accept Extern RUN				
<b>n112</b>	Starting Point For OL at Low Frequency <b>(Low Frq OL2 Start)</b>			0.0 to 6.0	6.0 (Hz)		
<b>n113</b>	Continuous Operation Level at 0 Hz <b>(OL2 Level @ 0 Hz)</b>			25 to 100	50 (%)		
<b>n114</b>	Square Root N Monitor Gain <b>(Sqr Root N Gain)</b>	$U1-14 = \sqrt{\frac{FI \text{ level}}{10}} \times n114 \times 100$		0 to 99	0		
<b>n115</b>	kVA Selection <b>(Inverter kVA Sel)</b>			00 to 35	<b>See Note 3</b>		Table A3-1
<b>n116</b>	CT/VT Selection	LED Setting	LCD Setting	0 or 1	0		Table A3-1
	<b>(CT/VT Selection)</b>	0	<b>CT Operation **</b>				
		1	VT Operation				

NOTES:

- \* ( ) values are parameter settings after a 3-Wire reset code has been entered.
- \*\* Factory setting for parameters with non-numerical data (**n002**, **n004**, etc.) is shown as **bold** followed by \*\* in "Description" column. Units shown in ( ) only appear with LCD display.
- 1. Initial value differs depending on V/f curve selected (**n010** setting). Values shown are initial values when **n010** is set to " 1 ".
- 2. To be accepted, the user setting must be between 10% and 120% of the drive's output current rating. See Table A3-1 and paragraph 5.26.
- 3. Initial value depends on drive capacity – see Table A3-1.
- 4. Range and increment may change due to a "custom" setting of **n023** — see paragraph 5.8.
- 5. When a parameter number is enclosed in a shaded box that parameter can also be examined and set by means of a Quick-Start Display.
- 6. **n054** setting of "7.0 kHz" ("10") is only available on GPD506V-B096 (CIMR-P5M40451F).

# Appendix 2. SPECIFICATIONS

**Table A2-1. Standard Specifications**

SECTION A. Input Voltage Related Specifications							
230V Class							
<b>Input Power</b>		Voltage : 3 Phase 200 / 208 / 220 / 230 VAC + 10%, – 15% Frequency : 50 / 60 Hz +/- 5%					
<b>Output Power</b>		Voltage : 0 - 230V (Output cannot be greater than input) Frequency: 0 - 400 Hz (V/Hz pattern selectable)					
NEW MODEL NO. CIMR-P5M	OLD MODEL NO. GPD506V-	RATED kVA	NOMINAL HP (@ 230V)	100% CONT. OUTPUT AMPS	RATED INPUT AMPS	RECOMMENDED MCCB RATING (1) (AMPS)	RECOMMENDED INPUT FUSING (AMPS) (2)
20P41F	A003	1.2	0.75	3.2	3.9	7	5.6
20P71F	A006	2.3	1 & 1.5	6.0	7.2	15	10
21P51F	A008	3.0	2	8.0	9.6	15	12
22P21F	A011	4.2	3	11.0	13.2	15	17.5
23P71F	A017	6.7	5	17.5	21	25	30
25P51F	A027	9.5	7.5 & 10	27	33	40	45
27P51F	A036	13.0	15	36	44	55	60
20111F	A054	19.0	20	54	65	75	90
20151F	A068	24	25	68	82	100	100
20181F	A080	30	30	80	88	105	125
20221F	A104	37	40	104	115	135	175
20300F	A130	50	50	130	143	165	200
20370F	A160	61	60	160	176	205	250
20450F	A192	70	75	192	212	245	300
20550F	A248	85	100	248	270	315	400
20750F	A312	110	125	312	344	400	400
460V Class							
<b>Input Power</b>		Voltage : 3 Phase 380 / 400 / 415 / 440 / 460 VAC + 10%, – 15% Frequency : 50 / 60 Hz +/- 5%					
<b>Output Power</b>		Voltage : 0 - 460V (Output cannot be greater than input) Frequency: 0 - 400 Hz (V/Hz pattern selectable)					
NEW MODEL NO. CIMR-P5M	OLD MODEL NO. GPD506V-	RATED kVA	NOMINAL HP (@ 460V)	100% CONT. OUTPUT AMPS	RATED INPUT AMPS	RECOMMENDED MCCB RATING (1) (AMPS)	RECOMMENDED INPUT FUSING (AMPS) (2)
40P41F	B001	1.4	0.75	1.9	2.2	3	3
40P71F	B003	2.6	1 & 2	3.6	4.1	7	6
41P51F	B004	3.7	3	5.1	5.8	7	8
43P71F	B008	6.1	5	8.5	9.6	15	12
44P01F	B011	8.6	7.5	11.7	13.2	20	17.5
45P51F	B014	11	10	14.8	16.8	20	20
47P51F	B021	14	15	21.0	26	30	30
40111F	B027	21	20	28.6	33	40	45
40151F	B034	26	25	34	40	50	50
40181F	B041	31	30	41	46	55	70
40221F	B052	40	40	52	58	70	90
40301F	B065	50	50	65	72	85	100
40371F	B080	61	60	80	88	105	125
40451F	B096	73	75	96	106	125	150
40551F	B128	98	100	128	141	165	200
40750F	B180	130	125 & 150	180	198	230	300
41100F	B240	170	200	240	264	305	400
41600F	B302	230	250	302	330	380	400
41850F	B380	260	300	380	456	525	600
42200F	B506	340	350 & 400	506	608	700	400 (3)
43000F	B675	460	500	675	810	935	450 (3)

(1) Molded-case circuit breaker must be rated for at least 18,000 RMS symmetrical amperes interrupting capacity.

(2) Fuses should be of the current-limiting, time-delay type offering protection for semiconductor devices.

(3) Two fuses of this rating are required for each phase.

(table continued on next page)

**Table A2-1. Standard Specifications (Continued)**

<b>SECTION A. Input Voltage Related</b>						
<b>600V Class drive</b>						
<b>Input Power</b>		Voltage : 3 Phase 500 / 575 / 600 VAC +/- 10% Frequency : 50 / 60 Hz +/- 5%				
<b>Output Power</b>		Voltage : 0 - 600V (proportional to input voltage) Frequency: 0 - 400 Hz (V/Hz pattern selectable)				
<b>MODEL NO. CIMR-P5M</b>	<b>RATED kVA</b>	<b>NOMINAL HP (@ 600V)</b>	<b>100% CONT. OUTPUT AMPS</b>	<b>RATED INPUT AMPS</b>	<b>RECOMMENDED MCCB RATING (1) (AMPS)</b>	<b>RECOMMENDED INPUT FUSING (AMPS) (2)</b>
51P51F	2	2 & 3	3.9	4.3	10	10
52P21F	3	3	4.6	5.1	10	10
53P71F	5	5	7.0	7.7	20	15
55P51F	7.5	7.5 & 10	11.0	12.1	20	25
57P51F	10	10	14.0	15.4	20	3
50111F	15	15	19	21	30	40
50151F	20	20	25	28	50	50
50181F	25	25	30	33	60	60
50221F	30	30	36	40	60	70
50301F	40	40	46	51	100	100
50371F	50	50	58	64	100	125
50451F	60	60	69	76	100	156
50551F	75	75	86	95	150	200
50751F	100	100	111	122	225	250
50900F	125	125 & 150	145	160	225	300
51100F	150	200	192	211	300	400
51600F	200	200	224	246	400	500

(1) Molded-case circuit breaker must be rated for at least 18,000 RMS symmetrical amperes interrupting capacity.

(2) Fuses should be of the current-limiting time-delay type offering protection for semi-conductor devices.



**Table A2-1. Standard Specifications (Continued)**

<b>SECTION B. ALL GPD 506/P5s</b>		
Control Characteristics	Control Method	Sine Wave PWM
	Frequency Regulation	Digital command: 0.01% (-10 to 40°C) (+14 to 104°F)
		Analog command: 0.1% (15 to 35°C) (59 to 95°F)
	Frequency Resolution	Digital Operator reference: 0.1 Hz Analog reference: 0.06 Hz/60Hz
	Output Frequency Resolution	0.01 Hz
	Frequency Setting Signal	0 to 10 VDC (20K Ohms), 4-20mA (250 Ohms)
	Accel / Decel Time	0.1 to 3600 sec (Accel / Decel time setting independently)
	Braking Torque	Approximately 20%
	V/F Pattern Selection	1 Preset Pattern:  1 Custom Pattern: defined by parameter settings.
Protective Functions	Motor Overload Protection	Electronic thermal overload relay
	Instantaneous Overcurrent	Motor coasts to a stop at approximately 180% rated current (200% for GPD506V-A068 (CIMR-P5M20151F) & below, -B034 (40151F) & below), and 51P51F thru 51600F.
	Fuse Blown Protection	Motor coasts to a stop by blown fuse.
	Overload	Motor coasts to a stop after 60 sec. of a 120% overload condition.
	Overvoltage	Motor coasts to a stop if drive DC bus voltage exceeds 410 VDC (230V unit), 820VDC (460V unit), 1050VDC (600V unit).
	Undervoltage	Motor coasts to a stop if drive DC bus voltage drops to 190 VDC or below (230V unit), 380 VDC or below (460V unit), 546 VDC or below (600V unit).
	Momentary Power Failure	Factory setting provides for motor to coast to a stop after momentary power failure of more than 15 ms. Can be reprogrammed to allow continuous operation (ride-through) during power failure of up to 2 seconds or longer (see Note 2).
	Heatsink Overheat	Thermoswitch
	Stall Prevention	Stall prevention at acceleration/deceleration and constant speed operation.
	Ground Fault	Provided by electronic circuit.
	Power Charge Indication	"CHARGE" lamp remains lit until bus voltage drops below 50 V.

**Table A2-1. Standard Specifications (Continued)**

<b>SECTION B. ALL GPD 506/P5s (Continued)</b>		
Environmental Conditions	Location	Indoor (protected from corrosive gases and dust).
	Ambient Temperature	-10 to 40°C (+14 to 104°F) for NEMA 1; -10 to 45°C (+14 to 113°F) for protected chassis
	Storage Temperature (Note 3)	-20 to 60°C (-4 to 140°F)
	Humidity	95% RH (no condensation)
	Vibration	1 G at less than 20 Hz, up to 0.2 G at 20 to 50 Hz.

NOTES:

1. Overload capacity: 120% of rated for 60 sec.
2. See paragraph 5.17 for detailed information.
3. Temperature during shipping. Storing in this temperature for a long period may deteriorate main circuit capacitor.

# Appendix 3. CAPACITY RELATED PARAMETERS

If a Control PCB is changed, the next time the drive is powered up parameter **n115** must be set to the appropriate value listed in Table A3-1 for the drive Model No. This will automatically program the values of all other parameters listed in the table to the factory settings for that particular drive rating.

**Table A3-1. Parameters Related to GPD 506/P5 Capacity**

NEW MODEL NO. CIMR-P5M	OLD MODEL NO. GPD 506V-	NOMINAL HP	OUTPUT AMPS	PARAMETER									
				<b>n115</b> (H)	<b>n033</b> (Amps)	<b>n054</b>	<b>n057</b> (sec.)	<b>n058</b> (%)	<b>n059</b> (sec.)	<b>n073</b> (%)	<b>n074</b> (%)	<b>n097</b>	<b>n116</b>
<b>230 V</b>													
20P41F	A003	0.75	3.2	0	1.9	15.0 kHz (6)	0.5	100	0.7	170	160	288.2	CT (0)
20P71F	A006	1 & 1.5	6	1	3.3	15.0 kHz (6)	0.5	100	1.0	170	160	223.7	CT (0)
21P51F	A008	2	8	2	6.2	15.0 kHz (6)	0.5	100	1.0	170	160	169.4	CT (0)
22P21F	A011	3	11	3	8.5	15.0 kHz (6)	0.5	100	1.0	170	160	156.8	CT (0)
23P71F	A017	5	17.5	4	14.0	15.0 kHz (6)	0.5	100	2.0	170	160	122.9	CT (0)
25P51F	A027	7.5 & 10	27	5	19.6	10.0 kHz (4)	0.7	100	2.0	170	160	94.75	VT (1)
27P51F	A036	15	36	6	26.6	10.0 kHz (4)	0.7	100	2.0	170	160	72.69	VT (1)
20111F	A054	20	54	7	39.7	10.0 kHz (4)	0.7	100	2.0	170	160	70.44	VT (1)
20151F	A068	25	68	8	53.0	10.0 kHz (4)	0.7	100	2.0	170	160	63.13	VT (1)
20181F	A080	30	80	9	65.8	15.0 kHz (6)	1.0	100	2.0	120	120	57.87	VT (1)
20221F	A104	40	104	A	77.2	15.0 kHz (6)	1.0	100	2.0	120	120	51.79	VT (1)
20300F	A130	50	130	b	105.0	10.0 kHz (4)	1.0	80	2.0	120	120	46.27	VT (1)
20370F	A160	60	160	C	131.0	10.0 kHz (4)	1.0	80	2.0	120	120	38.16	VT (1)
20450F	A192	75	192	d	156.0	10.0 kHz (4)	1.0	80	2.0	120	120	35.78	VT (1)
20550F	A248	100	248	E	190.0	8.0 kHz (3)	1.0	80	2.0	120	120	31.35	VT (1)
20750F	A312	125	312	F	224.0	8.0 kHz (3)	1.0	80	2.0	120	120	23.10	VT (1)
<b>460 V</b>													
40P41F	B001	0.75	1.8	20	1.0	10.0 kHz (4)	0.5	100	1.0	170	160	576.4	CT (0)
40P71F	B003	1 & 2	3.4	21	1.6	10.0 kHz (4)	0.5	100	1.0	170	160	447.4	CT (0)
41P51F	B004	3	4.8	22	3.1	10.0 kHz (4)	0.5	100	1.0	170	160	338.8	CT (0)
43P71F	B008	5	8	24	7.0	10.0 kHz (4)	0.5	100	2.0	170	160	313.6	CT (0)
44P01F	B011	7.5	11	25	7.0	10.0 kHz (4)	0.7	100	2.0	170	160	245.8	CT (0)
45P51F	B014	10	14	26	9.8	10.0 kHz (4)	0.7	100	2.0	170	160	189.5	CT (0)
47P51F	B021	15	21	27	13.3	10.0 kHz (4)	0.7	100	2.0	170	160	145.4	CT (0)
40111F	B027	20	27	28	19.9	10.0 kHz (4)	0.7	100	2.0	170	160	140.9	CT (0)
40151F	B034	25	34	29	26.5	10.0 kHz (4)	0.7	100	2.0	170	160	126.3	CT (0)
40181F	B041	30	41	2A	32.9	10.0 kHz (4)	1.0	100	2.0	120	120	115.7	VT (1)
40221F	B052	40	52	2b	38.6	8.0 kHz (3)	1.0	100	2.0	120	120	103.6	VT (1)
40301F	B065	50	65	2C	52.3	8.0 kHz (3)	1.0	100	2.0	120	120	92.54	VT (1)
40371F	B080	60	80	2d	65.6	5.0 kHz (2)	1.0	100	2.0	120	120	76.32	VT (1)
40451F	B096	75	96	2E	79.7	5.0 kHz (2)	1.0	100	2.0	120	120	71.56	VT (1)

(table continued on next page)

**Table A3-1. Parameters Related to GPD 506/P5 Capacity - Continued**

NEW MODEL NO. CIMR-P5M	OLD MODEL NO. GPD 506V-	NOMINAL HP	OUTPUT AMPS	PARAMETER									
				<i>n115</i> (H)	<i>n033</i> (Amps)	<i>n054</i>	<i>n057</i> (sec.)	<i>n058</i> (%)	<i>n059</i> (sec.)	<i>n073</i> (%)	<i>n074</i> (%)	<i>n097</i>	<i>n116</i>
<b>4 6 0 V (Continued)</b>													
40551F	B128	100	128	2F	98.0	5.0 kHz (2)	1.0	80	2.0	120	120	67.20	VT (1)
40750F	B180	125 & 150	180	30	120.0	5.0 kHz (2)	1.0	80	2.0	120	120	46.20	VT (1)
41100F	B240	200	240	31	175.0	5.0 kHz (2)	2.0	80	2.0	120	120	36.23	VT (1)
41600F	B302	250	302	32	245.0	5.0 kHz (2)	2.0	80	2.0	120	120	30.13	VT (1)
41850F	B380	300	380	33	302.0	2.5 kHz (9) *	2.0	80	2.0	120	120	30.57	VT (1)
42200F	B506	350 & 400	506	34	368.0	2.5 kHz (9) *	2.0	80	2.0	120	120	27.13	VT (1)
43000F	B675	500	675	35	490.0	2.5 kHz (9) *	2.0	80	2.0	120	120	21.76	VT (1)
<b>6 0 0 V</b>													
51P51F	N/A	2 & 3	3.9	42	2.7	10.0 kHz (4)	0.5	60	1.0	120	120	0.0	VT (1)
52P21F	N/A	3	4.1	43	3.9	10.0 kHz (4)	0.5	60	1.0	120	120	0.0	VT (1)
53P71F	N/A	5	7.0	44	6.1	10.0 kHz (4)	0.5	60	2.0	120	120	0.0	VT (1)
55P51F	N/A	7.5 & 10	11.0	45	9.0	10.0 kHz (4)	0.5	60	2.0	120	120	0.0	VT (1)
57P51F	N/A	10	12.5	46	11.0	10.0 kHz (4)	0.5	60	2.0	120	120	0.0	VT (1)
50111F	N/A	15	19	47	17.0	10.0 kHz (4)	0.5	60	2.0	120	120	0.0	VT (1)
50151F	N/A	20	25	48	22.0	10.0 kHz (4)	0.5	60	2.0	120	120	0.0	VT (1)
50181F	N/A	25	30	49	27.0	10.0 kHz (4)	0.5	60	2.0	120	120	0.0	VT (1)
50221F	N/A	30	36	4A	32.0	10.0 kHz (4)	0.5	60	2.0	120	120	0.0	VT (1)
50301F	N/A	40	46	4B	41.0	10.0 kHz (4)	1.0	60	2.0	120	120	0.0	VT (1)
50371F	N/A	50	58	4C	52.0	10.0 kHz (4)	1.0	60	2.0	120	120	0.0	VT (1)
50451F	N/A	60	69	4D	62.0	10.0 kHz (4)	1.0	60	2.0	120	120	0.0	VT (1)
50551F	N/A	75	86	4E	77.0	10.0 kHz (4)	1.0	60	2.0	120	120	0.0	VT (1)
50751F	N/A	100	111	4F	99.0	8.0 kHz (3)	1.0	60	2.0	120	120	0.0	VT (1)
50900F	N/A	125 & 150	145	50	125.0	2.5 kHz (1)	2.0	60	2.0	120	120	0.0	VT (1)
51100F	N/A	200	192	51	144.0	2.5 kHz (1)	2.0	60	10.0	120	120	0.0	VT (1)
51600F	N/A	200	224	52	192.0	2.5 kHz (1)	2.0	60	10.0	120	120	0.0	VT (1)

NOTES:

\* 2.5 kHz is maximum carrier frequency — see paragraph 5.5 for detailed information.

# Appendix 4. GPD 506/P5 SPARE PARTS

New Drive Model No. CIMR-P5M	Old Drive Model No. GPD506V-	Power Module Part No. 5P30-					Transistor Module Part No. 5P30-							Diode Module Part No. 5P50-					
		0174	0175	0178	0154	0155	0156	0157	0158	0159	0160	0161	0182	0477	0478	0479	0480	0481	0482
20P41F	A003	1																	
20P71F	A006		1																
21P51F	A008		1																
22P21F	A011			1															
23P71F	A017				1														
25P51F	A027				1														
27P51F	A036					1													
20111F	A054							3							1				
20151F	A068								3						1				
20181F	A080									3					2				
20221F	A104									3					2				
20300F	A130										6						6		
20370F	A160											6							6
20450F	A192												6						6
20550F	A248													6					6
20750F	A312														12				6

No Diode Module in these Drive Model No's; diodes are contained in Power Module.

New Drive Model No. CIMR-P5M	Old Drive Model No. GPD506V-	Power PCB Part No. 5P90-								Gate Drive PCB Part No. 5P90-					Control PCB Part No. 5P90-		
		0422	0423	0424	0425	0426	0427	0428	0429	0430	0410	0414	0415	0416	0417	0528	0529
20P41F	A003	1														1	
20P71F	A006		1													1	
21P51F	A008			1												1	
22P21F	A011				1											1	
23P71F	A017					1										1	
25P51F	A027						1									1	
27P51F	A036							1								1	
20111F	A054								1							1	
20151F	A068									1						1	
20181F	A080										1						1
20221F	A104									1							1
20300F	A130											1					1
20370F	A160												1				1
20450F	A192													1			1
20550F	A248													1			1
20750F	A312														1		1

New Drive Model No. CIMR-P5M	Old Drive Model No. GPD506V-	Cooling Fan Part No. 5P16-							DC Bus Fuse Part No. 5P17-								Control Fuse Part No. 5P17-				
		0057	0058	0059	0061	0050	0062	0051	0504	0506	0488	0480	0481	0482	0483	0484	0485	0486	0487	0500	0502
20P41F	A003								1											1	
20P71F	A006								1											1	
21P51F	A008									1										1	
22P21F	A011	1									1									1	
23P71F	A017	1										1								1	
25P51F	A027	1											1							1	
27P51F	A036	2												1						1	
20111F	A054		2											1						1	
20151F	A068		2												1					1	
20181F	A080			1	1											1				1	
20221F	A104			1	1											1				1	
20300F	A130					3	1										3				1
20370F	A160					3	1										3				1
20450F	A192					3	1										3				1
20550F	A248					3	1											3			1
20750F	A312					1	3												3		1

### IMPORTANT

Numbers represent total quantity used in one Drive. To determine adequate inventory of spare parts, Yaskawa suggests using listed value for quantities 2 and below. If listed value is greater than 2, factory suggests 1/3 of total listed.

New Drive Model No. CIMR-P5M	Old Drive Model No. GPD506V-	Power Module Part No. 5P30-				Transistor Module Part No. 5P30-						Xstr/Heatsink Assy Part No. 5P30-			Diode Module Part No. 5P50-								
		0171	0162	0163	0164	0165	0166	0167	0168	0150	0169	0152	0288	0289	0290	0483	0484	0485	0486	0487	0488	0496	
40P41F	B001	1																					
40P71F	B003	1																					
41P51F	B004	1																					
43P71F	B008		1																				
44P01F	B011		1																				
45P51F	B014			1																			
47P51F	B021				1																		
40111F	B027					3													1				
40151F	B034					3													1				
40181F	B041					3													2				
40221F	B052						3												2				
40301F	B065						3												2				
40371F	B080							3												2			
40451F	B096							3												2			
40551F	B128									6												6	
40750F	B180										6											6	
41100F	B240											12											6
41600F	B302												12										6
41850F	B380													3									6
42200F	B506														3								6
43000F	B675															3							9

New Drive Model No. CIMR-P5M	Old Drive Model No. GPD506V-	Power PCB						Gate Drive PCB						Control PCB Part No. 5P90-					
																0528	0529		
40P41F	B001																	1	
40P71F	B003																	1	
41P51F	B004																	1	
43P71F	B008																	1	
44P01F	B011																	1	
45P51F	B014																	1	
47P51F	B021																	1	
40111F	B027																	1	
40151F	B034																	1	
40181F	B041																		1
40221F	B052																		1
40301F	B065																		1
40371F	B080																		1
40451F	B096																		1
40551F	B128																		1
40750F	B180																		1
41100F	B240																		1
41600F	B302																		1
41850F	B380																		1
42200F	B506																		1
43000F	B675																		1

**IMPORTANT**

Numbers represent total quantity used in one Drive. To determine adequate inventory of spare parts, Yaskawa suggests using listed value for quantities 2 and below. If listed value is greater than 2, factory suggests 1/3 of total listed.

New Drive Model No. CIMR-P5M	Old Drive Model No. GPD506V-	Cooling Fan Part No. 5P16-									DC Bus Fuse Part No. 5P17-									Control Fuse Part No. 5P17-			
		0057	0058	0059	0061	0060	0050	0062	0051	0064	0504	0488	0480	0489	0490	0491	0492	0477	0478	0479	0500	0502	0503
40P41F	B001										1										1		
40P71F	B003										1										1		
41P51F	B004										1										1		
43P71F	B008	1										1									1		
44P01F	B011	1										1									1		
45P51F	B014	1											1								1		
47P51F	B021	2											1								1		
40111F	B027		2												1						1		
40151F	B034		2												1						1		
40181F	B041			1	1										1						1		
40221F	B052			1	1										1						1		
40301F	B065				1	2										1					1		
40371F	B080				1	2										1					1		
40451F	B096				1	2										1					1		
40551F	B128						3	1									3				1		
40750F	B180						3	1									3				1		
41100F	B240						3	1											3		1		
41600F	B302							1	3													1	
41850F	B380										3											1	
42200F	B506										3												1
43000F	B675										3												1

No DC Bus Fuse in these Drive Model No's;  
fuses are contained in Transistor/Heatsink Assembly.

**IMPORTANT**

Numbers represent total quantity used in one Drive. To determine adequate inventory of spare parts, Yaskawa suggests using listed value for quantities 2 and below. If listed value is greater than 2, factory suggests 1/3 of total listed.

Drive Model No. CIMR-P5M	Power Module Part No. 5P30-					Transistor Module Part No. STR__						Diode Module						
	0179	0162	0163	0164	0165	1217	1219	1220	1221	1200	1201	Part No. 5P50-						Part No. SID3047
												0483	0484	0485	0491	0492	0487	
51P51F	1											No Diode in these Drive Model Nos.; diodes are contained in Power Module.						
52P21F	1																	
53P71F		1																
55P51F			1									1						
57P51F				1								1						
50111F					1								1					
50151F					1								1					
50181F						3								1				
50221F						3								1				
50301F							3							1				
50371F								3						1				
50451F								3							1			
50551F									3							3		
50751F									3								3	
50900F										6								6
51100F												6						9
51600F												6						9

Drive Model No. CIMR-P5M	Power PCB Part No. ETP615__					Gate Drive PCB Part No. ETC615__						Control PCB
	860	870	880	890	900	900	910	920	930	940	960	ETC616980- SXXXX
51P51F	1											1
52P21F	1											1
53P71F		1										1
55P51F			1									1
57P51F				1								1
50111F					1							1
50151F					1							1
50181F						1						1
50221F						1						1
50301F							1					1
50371F							1					1
50451F							1					1
50551F								1				1
50751F									1			1
50900F										1		1
51100F											1	1
51600F											1	1

Drive Model No. CIMR-P5M	Cooling Fan Part No. 5P16-			DC Bus Fuse Part No.									
	0057	0058	0059	FU2067	50208016	50208017	FU2068	50205052	50205053	50205054	50208018	50208019	50208020
51P51F	1			1									
52P21F	1			1									
53P71F	1				1								
55P51F	2				1								
57P51F	2					1							
50111F		2				1							
50151F		2					1						
50181F			1					1					
50221F			1					1					
50301F			2						1				
50371F			2						1				
50451F			2						1				
50551F			2							1			
50751F			2							1			
50900F			2								1		
51100F			2									1	
51600F			2										1

**IMPORTANT**

Numbers represent total quantity used in one Drive. To determine adequate inventory of spare parts, Yaskawa suggests using listed value for quantities 2 and below. If listed value is greater than 2, factory suggests 1/3 of total listed.



# Appendix 5. GPD 506/P5 DIMENSIONS

Table A5-1 lists dimensions for the drive in its standard enclosure. For information on other types of enclosures available, consult your Yaskawa representative.

**Table A5-1. Drive Size and Weight**

VOLTS	NEW MODEL NO. CIMR-P5M	OLD MODEL NO. GPD506V-	NOMINAL HP	ENCLOSURE TYPE	PHYSICAL DIMENSIONS (IN.)			MOUNTING DIM. (IN.)		WEIGHT (LB)	HEAT LOSS (WATTS)			
					H	W	D	H1	W1		Heatsink	Internal	Total	
2 3 0	20P41F	A003	0.75	NEMA 1	11.02	5.51	6.30	10.47	4.96	7	15	50	65	
	20P71F	A006	1 & 1.5		11.02	5.51	6.30	10.47	4.96	7	25	65	90	
	21P51F	A008	2		11.02	5.51	6.30	10.47	4.96	7	40	80	120	
		22P21F	A011	3	NEMA 1	11.02	5.51	7.09	10.47	4.96	10	80	60	140
		23P71F	A017	5		11.02	5.51	7.09	10.47	4.96	10	135	80	215
		25P51F	A027	7.5 & 10	NEMA 1	11.81	7.87	8.07	11.22	7.32	12	210	90	300
		27P51F	A036	15		11.81	7.87	8.07	11.22	7.32	13	235	110	345
		20111F	A054	20	NEMA 1	14.96	9.84	8.86	14.37	9.29	24	425	160	585
		20151F	A068	25		15.75	9.84	8.86	14.37	9.29	24	525	200	725
		20181F	A080	30		24.02	12.99	11.22	17.13	10.83	71	655	230	885
		20221F	A104	40		26.57	12.99	11.22	17.13	10.83	71	830	280	1110
		20300F	A130	50	Protected Chassis	26.57	16.73	13.78	25.59	12.60	134	1050	500	1550
		20370F	A160	60		26.57	16.73	13.78	25.59	12.60	137	1250	700	1950
		20450F	A192	75	Protected Chassis	31.50	18.70	13.78	30.51	14.57	176	1550	750	1950
20550F		A248	100	31.50		18.70	13.78	30.51	14.57	176	1950	1000	2950	
20750F		A312	125	36.42		22.64	15.75	35.24	17.52	298	2300	1300	3600	
4 6 0	40P41F	B001	0.75	NEMA 1	11.02	5.51	6.30	10.47	4.96	7	10	50	60	
	40P71F	B003	1 & 2		11.02	5.51	6.30	10.47	4.96	7	20	65	85	
		41P51F	B004	3	NEMA 1	11.02	5.51	7.09	10.47	4.96	9	30	80	110
		43P71F	B008	5		11.02	5.51	7.09	10.47	4.96	10	80	65	145
		44P01F	B011	7.5	NEMA 1	11.02	5.51	7.09	10.47	4.96	10	120	80	200
		45P51F	B014	10		NEMA 1	11.81	7.87	8.07	11.22	7.32	13	135	85
		47P51F	B021	15	11.81		7.87	8.07	11.22	7.32	13	240	120	360
			40111F	B027	20	NEMA 1	14.96	9.84	8.86	14.37	9.29	24	305	150
	40151F		B034	25	14.96		9.84	8.86	14.37	9.29	24	390	180	570
		40181F	B041	30	NEMA 1	24.02	12.99	11.22	17.13	10.83	68	465	195	660
		40221F	B052	40		24.02	12.99	11.22	17.13	10.83	68	620	260	880
		40301F	B065	50	NEMA 1	30.91	12.99	11.22	24.02	10.83	106	705	315	1020
		40371F	B080	60		NEMA 1	30.91	12.99	11.22	24.02	10.83	106	875	370
		40451F	B096	75	33.46		12.99	11.22	24.02	10.83	106	970	415	1385
		40551F	B128	100	Protected Chassis	32.28	17.91	13.78	31.30	13.78	174	1110	710	1820
	40750F	B180	125 & 150	32.28		17.91	13.78	31.30	13.78	176	1430	890	2320	
	41100F	B240	200	36.42		22.64	14.76	35.24	17.52	298	1870	1160	3030	
	41600F	B302	250	36.42		22.64	15.75	35.24	17.52	320	2670	1520	4190	
	41850F	B380	300	Protected Chassis	57.09	37.40	17.13	55.12	(1)	794	3400	1510	4910	
	42200F	B506	300 & 400		57.09	37.40	17.13	55.12	(1)	794	4740	2110	6850	
	43000F	B675	500		62.99	37.80	17.91	61.02	(1)	926	6820	2910	9730	

(1) 3 mounting holes top, 3 mounting holes bottom; consult Yaskawa for horizontal hole spacing.

**Table A5-1. Drive Size and Weight**

VOLTS	MODEL NO. CIMR-P5M	NOMINAL HP	ENCLOSURE TYPE	PHYSICAL DIMENSIONS (IN.)			MOUNTING DIM. (IN.)		WEIGHT (LB)	HEAT LOSS (Watts)		
				H	W	D	H1	W1		Heatsink Internal		Total
6 0 0 V	51P51F	2 & 3	NEMA 1	11.02	5.51	7.08	10.47	4.96	9	35	55	90
	52P21F	3	NEMA 1	11.02	5.51	7.08	10.47	4.96	9	45	60	105
	53P71F	5	NEMA 1	11.81	7.87	8.07	11.22	7.32	13	65	75	140
	55P51F	7.5 & 10	NEMA 1	11.81	7.87	8.07	11.22	7.32	14	100	105	205
	57P51F	10	NEMA 1	11.81	7.87	8.07	11.22	7.32	14	130	125	255
	50111F	15	NEMA 1	14.96	9.84	8.85	14.37	9.29	29	180	150	330
	50151F	20	NEMA 1	14.96	9.84	8.85	14.37	9.29	29	250	210	460
	50181F	25	NEMA 1	29.53	15.75	11.22	28.74	11.81	97	310	230	540
	50221F	30	NEMA 1	29.53	15.75	11.22	28.74	11.81	97	380	340	720
	50301F	40	NEMA 1	33.47	22.64	11.81	32.48	18.70	159	430	390	820
	50371F	50	NEMA 1	33.47	22.64	11.81	32.48	18.70	159	680	540	1220
	50451F	60	NEMA 1	33.47	22.64	11.81	32.48	18.70	159	900	750	1650
	50551F	75	NEMA 1	41.34	22.64	12.80	40.35	18.70	198	1000	750	1750
	50751F	100	NEMA 1	41.97	22.64	12.80	40.35	18.70	198	1100	1150	2250
	50900F	125 & 150	Protected Chassis	49.21	22.64	12.99	48.23	18.70	267	1150	1200	2350
	51100F	200		62.99	22.64	13.98	61.81	18.70	324	1400	1800	3200
	51600F	200		62.99	22.64	13.98	61.81	18.70	335	1870	2830	4700

## Appendix 6. DYNAMIC BRAKING CONNECTIONS

**GENERAL.** Dynamic braking (DB) enables the motor to be brought to a smooth and rapid stop. This is achieved by dissipating the regenerative energy of the AC motor across the resistive components of the Dynamic Braking option. For further details on dynamic braking operation, see the instruction sheet shipped with dynamic braking components.

The GPD506-A003 thru -A036 (20P41F thru 27P51F) and -B001 thru -B034 (40P41F thru -40151F) have an integral braking transistor and only require the addition of a Remote Mount Resistor Unit or a Heat Sink Mount Resistor. All higher rated drives require the use of a Braking Transistor Unit *and* a Remote Mount Resistor Unit.

Remote Mount Resistor Units typically mount outside of an electrical enclosure. Braking Transistor Units mount inside of an electrical enclosure. Heat Sink Mount Resistors mount to the back of the drive, attaching directly to the heat sink.

Available dynamic braking components are listed in Table A6-1 through A6-4.

**Table A6-1.** Dynamic Braking - 3% Duty Cycle - 230V & 460V

Drive			Heat Sink Mount Resistor							
Rated Input	New Model No. CIMR-P5M	Old Model No. GPD506V-	Part No.	Qty Reqd	Resistance (Ohms) (Each)	Power (Watts) (Each)	Approx. Braking Torque (%)	Dimensions (Inches)		
								Height	Width	Depth
230 V	20P41F	A003	50185430	1	200	150	220	7.16	1.73	0.51
	20P71F	A006	50185430	1	200	150	220	7.16	1.73	0.51
	21P51F	A008	50185431	1	100	150	125	7.16	1.73	0.51
	22P21F	A011	50185432	1	70	150	120	7.16	1.73	0.51
	23P71F	A017	50185433	1	62	150	100	7.16	1.73	0.51
460 V	40P41F	B001	50185530	1	750	150	165	7.16	1.73	0.51
	40P71F	B003	50185531	1	400	150	120	7.16	1.73	0.51
	41P51F	B004	50185531	1	200	150	150	7.16	1.73	0.51

**Table A6-2.** Dynamic Braking - 10% Duty Cycle - 230V

Drive			Braking Transistor Unit						Remote Mount Resistor Unit								
Rated Input	New Model No. CIMR-P5M	Old Model No. GPD506V-	Part No. 46S03331-	Qty Reqd	Minimum Connectable Resistance Each (Ohms)	Dimensions (Inches)			Part No. 5P41-	Qty Reqd	Resistance (Ohms) (Each)	Power (Watts) (Each)	Approx Braking Torque (%)	Dimensions (Inches)			
						Height	Width	Depth						Height	Width	Depth	
230V	20P41F	A003	--	--	48	--	--	--	0825	1	200	250	150	5.00	14.00	4.00	
	20P71F	A006	--	--	48	--	--	--	0826	1	100	250	150	5.00	14.00	4.00	
	21P51F	A008	--	--	16	--	--	--	0826	1	100	250	115	5.00	14.00	4.00	
	22P21F	A011	--	--	16	--	--	--	0827	1	70	250	110	5.00	14.00	4.00	
	23P71F	A017	--	--	16	--	--	--	0828	1	40	846	115	5.00	14.00	7.00	
	25P51F	A027	--	--	9.6	--	--	--	0829	1	30	824	105	5.00	14.00	7.00	
	27P51F	A036	--	--	9.6	--	--	--	0830	1	20	1260	115	5.00	14.00	10.00	
	20111F	A054	0010	1	9.6	11.00	5.53	5.91	0831	1	13.6	1500	115	5.00	14.00	13.00	
	20151F	A068	0020	1	6.3	11.00	5.53	5.91	0832	1	10	1920	115	5.00	14.00	13.00	

**Table A6-3. Dynamic Braking - 10% Duty Cycle - 460V**

Drive		Braking Transistor Module							Remote Mount Resistor Unit							
Rated Input	New Model No. CIMR-P5M	Old Model No. GPD506V-	Part No. 46S03331-	Qty Reqd	Minimum Connectable Resistance Each (Ohms)	Dimensions (Inches)			Part No. 5P41-	Qty Reqd	Resistance (Ohms) (Each)	Power (Watts) (Each)	Approx Braking Torque (%)	Dimensions (Inches)		
						Height	Length	Depth						Height	Length	Depth
460 V	40P41F	B001	--	--	96	--	--	--	0835	1	750	600	150	5.00	14.00	7.00
	40P71F	B003	--	--	96	--	--	--	0836	1	400	500	115	5.00	14.00	4.00
	41P51F	B004	--	--	64	--	--	--	0837	1	250	500	125	5.00	14.00	4.00
	43P71F	B008	--	--	32	--	--	--	0838	1	150	500	125	5.00	14.00	4.00
	44P01F	B011	--	--	32	--	--	--	0839	1	100	975	125	5.00	14.00	7.00
	45P51F	B014	--	--	32	--	--	--	0840	1	75	1050	125	5.00	14.00	10.00
	47P51F	B021	--	--	32	--	--	--	0841	1	50	1600	125	5.00	14.00	13.00
	40111F	B027	--	--	20	--	--	--	0842	1	40	2050	120	5.00	21.00	10.00
40151F	B034	--	--	20	--	--	--	0843	1	32	2340	120	5.00	21.00	10.00	
GPD506V-B041 thru GPD506V-B302 (CIMR-P5M40181F thru 41600F) cannot be connected for Dynamic Braking.																
460 V	41850F	B380	0090	1	3	14.50	10.63	7.25	0849	1	4	19,600	80	14.00	29.00	18.00
	42200F	B506	0090	1	3	14.50	10.63	7.25	0849	1	4	19,600	70	14.00	29.00	18.00
	43000F	B675	0090	2	3	14.50	10.63	7.25	0849	2	4	19,600	95	14.00	29.00	18.00

**Table A6-4. Dynamic Braking - 10% Duty Cycle - 575V**

Drive		Braking Transistor Module							Remote Mount Resistor Unit						
Rated Input	Model No. CIMR-P5M	Part No. 46S03331-	Qty Reqd	Minimum Connectable Resistance Each (Ohms)	Dimensions (Inches)			Part No. 5P41-	Qty Reqd	Resistance (Ohms) (Each)	Power (Watts) (Each)	Approx Braking Torque (%)	Dimensions (Inches)		
					Height	Length	Depth						Height	Length	Depth
575V	51P51F	--	--	150	--	--	--	0851	1	150	840	150	5.00	14.00	7.00
	52P21F	--	--	150	--	--	--	0851	1	150	840	150	5.00	14.00	7.00
	53P71F	--	--	130	--	--	--	0851	1	150	840	150	5.00	14.00	7.00
	55P51F	--	--	90	--	--	--	0851	1	150	840	130	5.00	14.00	7.00
	57P51F	--	--	65	--	--	--	0852	1	100	1400	145	5.00	14.00	10.00
	50111F	--	--	44	--	--	--	0853	1	75	1680	130	5.00	14.00	13.00
	50151F	--	--	32	--	--	--	0854	1	50	2520	145	5.00	21.00	10.00
	50181F	--	--	26	--	--	--	0855	1	40	3000	145	5.00	21.00	10.00
	50221F	--	--	26	--	--	--	0856	1	38	3248	130	5.00	21.00	13.00
	50301F	0080	1	24	11.00	5.53	5.91	0857	1	33	3800	110	5.00	21.00	13.00
	50371F	0080	1	24	11.00	5.53	5.91	0858	1	27	4464	110	5.00	28.00	13.00
	50451F	0080	2	24	11.00	5.53	5.91	0858	2	27	4464	150	5.00	28.00	13.00
	50551F	0080	2	24	11.00	5.53	5.91	0858	2	27	4464	145	5.00	28.00	13.00
	50751F	0080	2	24	11.00	5.53	5.91	0858	2	27	4464	110	5.00	28.00	13.00
	50900F	0080	3	24	11.00	5.53	5.91	0858	3	27	4464	130	5.00	28.00	13.00
	51100F	0080	3	24	11.00	5.53	5.91	0858	3	27	4464	110	5.00	28.00	13.00
51600F	0080	4	24	11.00	5.53	5.91	0858	4	27	4464	110	5.00	28.00	13.00	

## INSTALLATION

This option should only be installed by a **TECHNICALLY QUALIFIED INDIVIDUAL** who is familiar with this type of equipment and the hazards involved.

### **WARNING**

**Hazardous voltage can cause severe injury or death. Lock all power sources feeding the drive in the "OFF" position.**

### **CAUTION**

**Failure to follow these installation steps may cause equipment damage or personnel injury.**

#### Preliminary Procedures

1. Disconnect all electrical power to the drive.
2. Remove drive front cover.
3. Use a voltmeter to verify that voltage is disconnected from incoming power terminals.

#### Heat Sink Mount Resistor Installation

1. Remove the drive from its mounting for access to the rear of the heat sink.
2. Attach the Heat Sink Mount Resistor on the back of the drive's heat sink, as shown in Figure A6-1.
3. Reinstall the drive in its mounting position.
4. Connect the leads from the Heat Sink Mount Resistor to drive terminals according to Figure A6-2.
5. Proceed to "ADJUSTMENTS" on page A6-7.

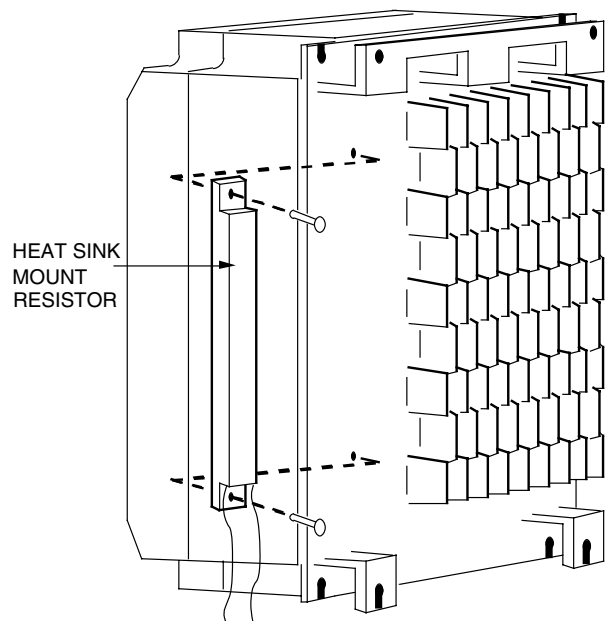

**Figure A6-1. Attaching Heat Sink Mount Resistor on Heat Sink**

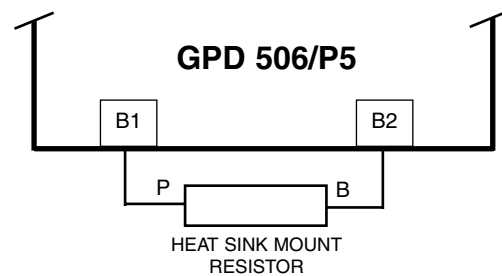

**Figure A6-2. Lead Connections For Heat Sink Mount Resistor**

**Remote Mount Resistor Unit Installation (for GPD506V-A003 thru -A036 [CIMR-P5M20P41F thru 27P51F], -B001 thru -B034 [CIMR-P5M40P41F thru 40151F]), and CIMR-P5M51P51F thru 50221F).**

**IMPORTANT**

Since the Remote Mount Resistor Unit, generates heat during dynamic braking operation, install it in a location away from other equipment.

1. Attach the Remote Mount Resistor Unit, maintaining a minimum 1.18 inch (30 mm) clearance on each side and a minimum 5.91 inch (150 mm) clearance top and bottom.

2. Remove the Remote Mount Resistor Unit cover to access its terminal block. Connect the Remote Mount Resistor Unit to the drive and to external control circuitry according to the chart at right and Figure A6-3.

Terminals	<b>B, P</b>	<b>1, 2 *</b>
Lead Size (AWG)	12-10	18-14 *
Lead Type	600V ethylene propylene rubber insulated, or equivalent	
Terminal Screw	M4	

\* Power leads for the Remote Mount Resistor Unit generate high levels of electrical noise; these signal leads must be grouped separately.

3. Reinstall and secure Remote Mount Resistor Unit cover and drive front cover.
4. Proceed to "ADJUSTMENTS" on page A6-8.

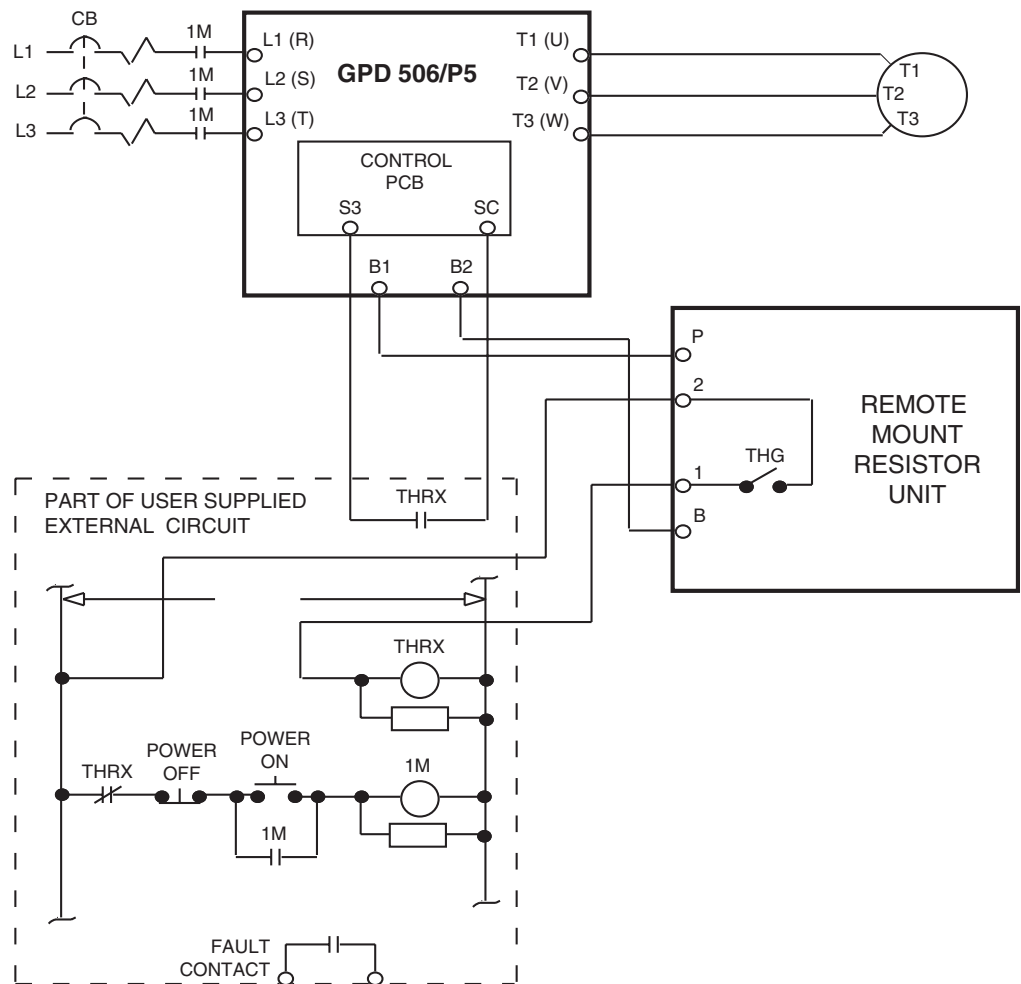

**Figure A6-3. Wiring Remote Mount Resistor Unit to Drive (GPD506V-A003 thru -A036 [CIMR-P5M20P41F thru 27P51F], -B001 thru -B034 [CIMR-P5M40P41F thru 40151F], and CIMR-P5M51P51F thru 50221F).**

**Braking Transistor Unit(s) and Remote Mount Resistor Unit(s) Installation  
(for GPD506V-A054 and -A068 [CIMR-P5M20111F and 20151F], -B380  
[CIMR-P5M41850F] and above, and CIMR-P5M50301F and above).**

**IMPORTANT**

Since the Remote Mount Resistor Unit generates heat during dynamic braking operation, install it in a location away from other equipment.

Select mounting locations for the Braking Transistor Unit(s) and Remote Mount Resistor Unit(s) so that wiring between the drive and the (Master) Braking Transistor Unit, and between each Braking Transistor Unit and its associated Remote Mount Resistor Unit, is less than 33 feet (10 m).

1. Mount the Braking Transistor Unit(s) on a vertical surface. A Braking Transistor Unit requires a minimum 1.18 inches (30 mm) clearance on each side and a minimum 3.94 inches (100 mm) clearance top and bottom. Attach the Remote Mount Resistor Unit maintaining a minimum 1.97 inches (50 mm) clearance on each side and a minimum 7.87 inches (200 mm) clearance on top.
2. In each Braking Transistor Unit, set the nominal line voltage jumper plug to the correct setting for the installation; this is factory set at the "230V/460V/575V" position. To access jumper plugs, remove plexiglass cover.
3. If multiple Braking Transistor Units are being installed, the unit closest to the drive should have the "SLAVE/MASTER" jumper plug on its PCB set to the "MASTER" position (factory setting); all others must have this jumper plug moved to the "SLAVE" position.
4. If a single Braking Transistor Unit and Remote Mount Resistor Unit are being installed, connect them to the drive and external control circuitry according to the chart below and Figure A6-4.

If two or more Braking Transistor Units and Remote Mount Resistor Units are being installed, connect them to the drive and to external circuitry according to the chart below and Figure A6-5.

UNIT	TERMINALS	LEAD SIZE (AWG)	LEAD TYPE	TERMINAL SCREWS
Remote Resistor Unit	B, P	12-10	600V ethylene propylene rubber insulated or equivalent	M5
	1, 2 *	18-14 *		M4
Braking Transistor Unit	P, Po, N, B	12-10	600V ethylene propylene rubber insulated, or equivalent	M4
	1, 2 *	18-14 *		

\* Power leads for the Remote Mount Resistor Unit generate high levels of electrical noise; these signal leads must be grouped separately.

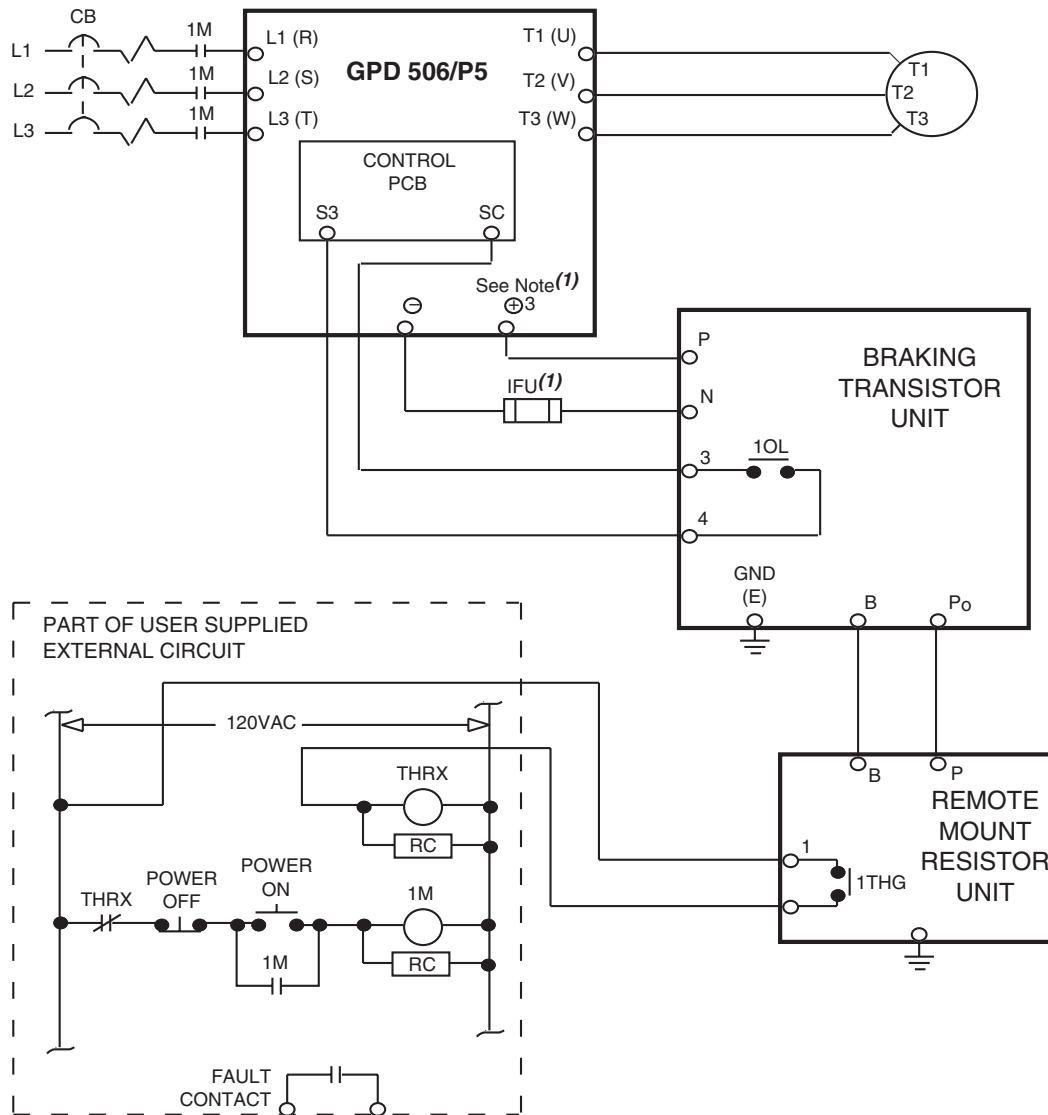
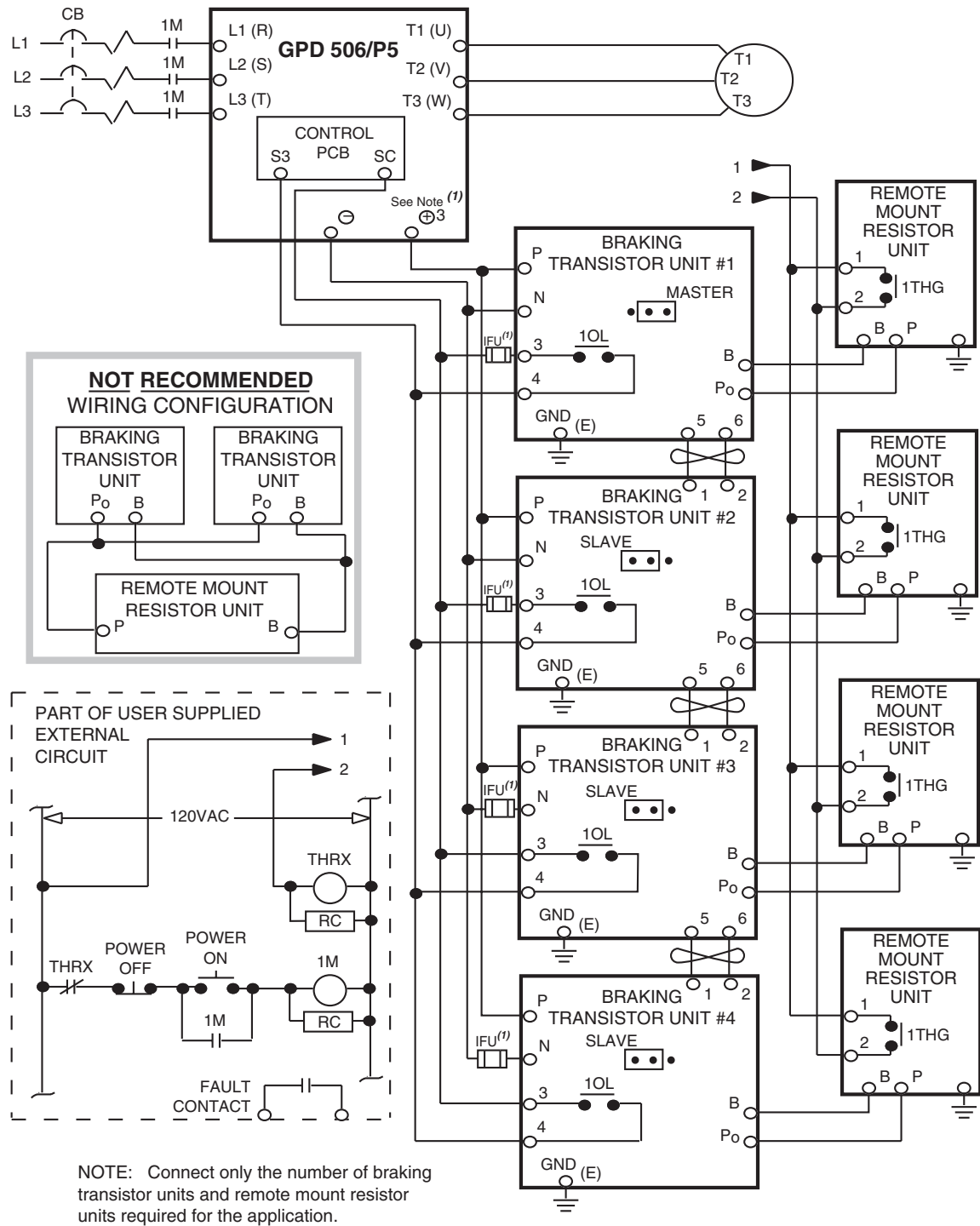

**Figure A6-4. Wiring Single Braking Transistor Unit and Remote Mount Resistor Unit to Drive (GPD506V-A054 and -A068 [CIMR-P5M20111F and 20151F], -B380 [CIMR-P5M41850F], and CIMR-P5M50301F thru 50371F).**

5. The Braking Transistor Unit and Remote Mount Resistor Unit MUST BE GROUNDED. Observe the following precautions:
  - Ground units per local electrical codes.
  - If the installation requires the Remote Mount Resistor Unit to be used without its enclosure (with grounding terminal), ground it by attaching a ground lead at one of the mounting screws.
  - Grounding resistance of the Braking Transistor Unit should be 100 ohms or less.

<sup>(1)</sup> Fuse required only if UL/CUL certification is needed. See separate instruction sheet 02Y00025-0393 for details.

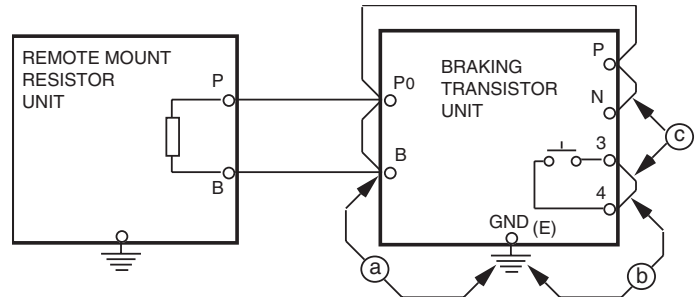



**Figure A6-5. Wiring Multiple Braking Transistor Units and Remote Mount Resistor Units to Drive (GPD506V-B506 and -B675 [CIMR-P5M42200F and 43000F], and CIMR-P5M50451F thru 51600F).**

<sup>(1)</sup> Fuse required only if UL/CUL certification is needed. See separate instruction sheet 02Y00025-0393 for details.

6. **IMPORTANT:** After wiring, test insulation resistance of each Braking Transistor Unit/Remote Mount Resistor Unit with a 900V megger as follows:
  - a. Disconnect leads between the Braking Transistor Unit and the drive. If equipment with semiconductors is connected across terminals 1 & 2 of the Braking Transistor Unit, remove the wiring.
  - b. Connect common leads (jumpers) across Braking Transistor Unit terminals N, P, Po, and B, and across 3 & 4, as shown in Figure A6-6.
  - c. Measure the insulation resistance at points a, b, and c in Figure A6-6 with the megger.



**Figure A6-6. Megger Testing Set-up**

## ADJUSTMENTS

7. ALL drives: Program **L3-04** to " 0 ", to disable stall prevention during deceleration.
8. Only with Heat Sink Mount Resistor: Program **L8-01** to " 1 ", to enable overheat protection for the braking resistor.

## OPERATION CHECK

9. During dynamic braking operation, verify that the "BRAKE" lamp inside the Braking Unit is lit.
10. During dynamic braking operations, ensure that the required deceleration characteristic is obtained. If not, contact MagneTek for assistance.
11. Reinstall and secure covers on the Braking Transistor Units, Remote Mount Resistor Units, and the drive.

## CAUTION

**During normal operation, the Braking Transistor Unit and the Remote Mount Resistor Unit enclosures must be kept closed, since high voltage is applied to the dynamic braking circuit.**

# INDEX

## - A -

**Accel** Function LED ..... 4-2, 4-3  
 Acceleration :  
   Stall Prev. Level During ..... 5-53  
   Time 1 ..... 5-3  
   Time 2 ..... 5-3  
 Analog Monitor Gain ..... 5-27  
 Analog Output, Multi-func.  
   (Term. AM-AC) ..... 5-27  
 At Set Speed, Stall Prev.  
   Level ..... 5-54  
 Auto Analog Input Sel. ....  
   ..... 5-15, 5-16  
 Auto Restart Attempts ..... 5-5  
 Auto Restart, Fault Contact  
   Selection During ..... 5-5  
 Auxiliary Input and Output  
   Power Option Devices ... 1-11

## - B -

Base Block, External ..... 5-33  
 Basic Programming ..... 4-5  
 Bias, Freq. Ref. .... 5-13  
 BPS Selection, Modbus ..... 5-23  
 Braking, DC Injection :  
   Current ..... 5-8  
   Time at Start ..... 5-8  
   Time at Stop ..... 5-8  
 Braking, Dynamic ..... A6-1

## - C -

Carrier Frequency ..... 5-6  
 Changeover, Local/Remote ... 5-21  
 Communication Error, Modbus  
   Stop Method at ... 6-2, A1-13  
 Compensation, Slip ..... 5-51  
 Conformance to European  
   EMC Directive ..... 1-11  
 Control Circuit Wiring ..... 1-8  
 Critical Freq. Rejection ..... 5-7  
 CT/VT Selection ..... A1-14  
 Current, DC Inj. Braking ..... 5-8  
 Current, Motor No-load ..... 5-57

## - D -

Deactivation Time, Momentary  
   Power Loss Ride-thru ... 5-26  
**Decel** Function LED ..... 4-2, 4-3  
 Deceleration :  
   Stall Prevention During ..... 5-53  
   Time 1 ..... 5-3  
   Time 2 ..... 5-3  
 Delay Time :  
   Feedback Loss Detection  
     (PID) ..... 5-47  
 Derivative Time (PID) ..... 5-48  
 Detection, Fdbk. Loss (PID) .. 5-47  
 Det'n, Modbus Time Out ..... A1-9  
 Detection Level :  
   Input Phase Loss ..... 5-63  
   Feedback Loss (PID) ..... 5-47  
   Overtorque (OL3) ..... 5-43  
 Detection Time :  
   Overtorque (OL3) ..... 5-43  
 Diagnostics — *see*  
   *Troubleshooting*  
 Digital Operator ..... 2-2, 4-1  
 Digital Operator Display  
   Selection ..... 5-9  
 Dimensions ..... A5-1  
 Displays, Monitor ..... 4-6  
 “Down Arrow” Key ..... 4-1  
**DSPL** key ..... 4-1  
 Dynamic Braking Connections .....  
   ..... A6-1

## - E -

Elapsed Timer 1 ..... A1-9  
 Elapsed Timer 2 ..... A1-9  
 Elapsed Timer Selection ..... A1-9  
 EMC Directive, European,  
   Conformance to ..... 1-11  
 Energy Saving :  
   Gain K2 ..... 5-11  
   Selection ..... 5-11  
   Tuning ..... 5-12  
   Volt. Lower Limit at 6Hz ... 5-11

Volt. Lower Limit at 60Hz .. 5-11  
 Enclosure ..... A5-1  
**ENTER** Key ..... 4-1  
 Environment ..... 1-1, A2-3  
 European EMC Directive,  
   Conformance to ..... 1-12

## - F -

Fault Contact Selection  
   During Auto Restart ..... 5-5  
**Fbias** Quick Start  
   Displays ..... 4-2, 4-3  
 Feedback Calibration  
   Gain (PID) ..... 5-47  
 Feedback Loss (PID) :  
   Detection Selection ..... 5-47  
   Detection Delay Time ..... 5-47  
   Detection Level ..... 5-47  
**Fgain** Quick Start  
   Displays ..... 4-2, 4-3  
**FLA** Quick Start  
   Displays ..... 4-2, 4-4  
**Fout** Quick Start Displays ..... 4-2  
   Display Selection ..... 5-9  
**Fref** Quick Start Displays ..... 4-2  
 Frequency :  
   Base ..... 5-61  
   Carrier ..... 5-6  
   Detection ..... 5-42  
   Max. Output ..... 5-61  
   Meter ..... 5-27  
   Min. Output ..... 5-61  
   Min. Output Voltage ..... 5-61  
   Output ..... 4-2  
   Prohibited ..... 5-7  
   Range ..... 5-17  
   Ref. Retention (Up/Down  
     & Sample/Hold) ..... 5-19  
 Frequency Detection Multi-  
   function Output ..... 5-42  
 Frequency Reference 1 ..... 5-31  
 Frequency Reference 2 ..... 5-31  
 Frequency Reference 3 ..... 5-31  
 Frequency Reference 4 ..... 5-31

**INDEX – Continued**

Frequency Reference :  
 Bias ..... 5-13  
 Gain ..... 5-13  
 Jog ..... 5-20, 5-31  
 Limit, Lower ..... 5-17  
 Limit, Upper ..... 5-17  
 Loss Detection, Operation  
     Method for ..... 5-18  
 Resolution, Modbus ..... 5-23  
 Retention ..... 5-19  
 Setting Method From  
     Digital Operator ..... 2-2  
 Function LEDs ..... 4-1, 4-2

**- G -**

Gain :  
 Analog Monitor ..... 5-27  
 Feedback Calib. (PID) ..... 5-47  
 Frequency Reference ..... 5-13  
 Proportional (PID) ..... 5-47  
 Torque Compensation ..... 5-59  
 Gain K2, Energy Saving ..... 5-11  
 Grounding ..... 1-9

**- I -**

Initialize Parameters ..... 5-50  
 Input Phase Loss Detection :  
     Delay Time (SPi) ..... 5-63  
     Level ..... 5-63  
 Input Selection  
     Auto Analog ..... 5-15  
     Manual Analog ..... 5-15  
     Multi-function Contact ..... 5-28  
 Input Voltage ..... A2-1  
 Inputs :  
     Analog ..... 1-15  
     Frequency Reference ..... 1-15  
 Inspection (Receiving) ..... 1-1  
 Installation ..... 1-1  
 Integral Time (PID) ..... 5-48

Integral Value Limit (PID) ..... 5-48  
 Integral Value Reset (PID) .... 5-48  
 Inverse PID ..... 5-46  
**lout** Function LED ..... 4-2  
 Iron Loss ..... 5-59

**- J -**

Jog Frequency Ref. .... 5-20, 5-29

**- K -**

Keypad — *see Digital Operator*  
 kVA Selection (**n115**) ..... A3-1

**- L -**

Lag Filter Time, Output (PID) 5-47  
 LEDs, Function ..... 4-1, 4-2  
 LEDs, Status Indicator ..... 4-1  
 Limit, Integral Value (PID) .... 5-48  
 Line-to-Line Res., Motor ..... 5-59  
 Local/Remote Changeover .... 5-21  
**LOCAL/REMOTE** Key ..... 4-1  
**LOC./REM.** Key Func. .... A1-2  
 Lower Limit, Freq. Ref. .... 5-17

**- M -**

Main Circuit :  
     Block Diagrams ..... 1-6, 1-7  
     Terminals ..... 1-3, 1-5  
     Input/Output Wiring ..... 1-2  
 Maintenance ..... 6-5  
 Manual Analog Input Sel. .... 5-15  
 Max. Output Frequency ..... 5-61  
 Max. Voltage ..... 5-61  
 Max. Volt. Output Freq. .... 5-61  
 Mechanical resonance — *see Critical Frequency Rejection*  
 Mid. Frequency Voltage ..... 5-61  
 Min. Base Block Time ..... 5-33

Min. Output Frequency ..... 5-61  
 Min. Output Volt. Freq. .... 5-61  
 Miscellaneous Protective  
     Features ..... 5-25  
 Modbus :  
     BPS Selection ..... 5-23  
     Freq. Resolution ..... 5-23  
     Parity Selection ..... 5-23  
     Stop Method at Comm.  
         Error ..... A1-13  
         Time Out Detection ..... A1-13  
     Slave Address ..... 5-23  
 Mode Selection ..... 5-22  
 Model Numbers, Drive .....  
     ..... A2-1, A5-1  
 Momentary Power Loss  
     Ride-through Selection .. 5-26  
 Monitor Displays ..... 4-6  
 Motor :  
     Iron Loss ..... 5-59  
     Line-to-Line Resistance ..... 5-59  
     No-load Current ..... 5-57  
     Overload Prot. Selection .... 5-57  
     Rated Current (FLA) ..... 4-4  
     Rated Voltage ..... 5-62  
     Switching — *see Speed Search*  
         Wiring ..... 1-2  
 Mounting :  
     Clearances ..... 1-1  
     Dimensions ..... A5-1  
     European EMC  
         Conformance ..... 1-11  
         Location ..... 1-1, A2-3  
 Multi-function Analog Output  
     (AM-AC) ..... 5-27  
 Multi-func. Contact Input  
     Selection ..... 5-28  
 Multi-func. Contact Output  
     Selection ..... 5-41  
 Multi-step Speed ..... 5-31

## INDEX – Continued

### - N -

Nameplate, Motor ..... 5-57  
 No-load Motor Current ..... 5-57

### - O -

Off-delay Timer ..... 5-36  
 Offset (PID) ..... 5-47  
 OH1 Stopping Method  
   Selection ..... A1-5  
 On-delay Timer ..... 5-36  
 Operation Method for Freq.  
   Ref. Loss Detection ..... 5-18  
 Operation Mode Selection .... 5-30  
 Operator Display ..... 4-1  
 Options — *see Peripheral  
 Devices*  
 Output, Analog, Multi-func. .. 5-27  
 Output Frequency :  
   Max. .... 5-61  
   Max. Voltage ..... 5-61  
   Min. .... 5-61  
 Output Lag Filter Time (PID) .. 5-47  
 Output, Multi-func., Freq.  
   Detection ..... 5-42  
 Output Phase Loss Detection :  
   Delay Time ..... 5-63  
   Level ..... 5-63  
 Output Selection, Multi-Func.  
   Contact ..... 5-41  
 Outputs  
   Analog ..... 5-27  
   Contact ..... 5-41  
 Overload Prot. Selection,  
   Motor ..... 5-57  
 Overtorque Detection (OL3) :  
   Function Selection ..... 5-43  
   Level ..... 5-43  
   Time ..... 5-43

### - P -

Parameters  
   Factory Reset (Initialize) .... 5-50  
   List ..... A1-1  
   Programming ..... 4-5  
 Parity Selection, Modbus ..... 5-23  
 Peripheral Devices :  
   AC reactor ..... 1-11  
   Molded-case circuit  
     breaker (MCCB) .... 1-11, A2-1  
   Noise filter ..... 1-11  
 PID Control ..... 5-45  
 PID Disable (Input) ..... 5-48  
 PID, Inverse ..... 5-46  
 PID Selection ..... 5-45  
 PID Settings ..... 5-47  
 Potentiometer ..... -v-  
 Power Loss Ride-thru Time .. 5-26  
 Power Rotation ..... A1-1  
 Power Supply ..... 1-2, A2-1  
 Preset speeds — *see  
 Multi-step Speeds*  
**PRGM** Function LED ..... 4-1, 4-4  
 Prohibited Frequency 1 ..... 5-7  
 Prohibited Frequency 2 ..... 5-7  
 Proh. Frequency Range ..... 5-7  
 Proportional Gain (PID) ..... 5-47  
 Protection :  
   Overcurrent ..... 6-2  
   Overheat ..... 6-1  
   Overtemperature ..... 6-1  
   Overtorque ..... 5-44  
   Overvoltage ..... 6-1  
   Thermal Overload ..... 5-57  
   Undervoltage ..... 6-1  
 Protective Functions,  
   Miscellaneous ..... 5-25  
 PWM Frequency — *see  
 Carrier Frequency*

### - R -

Range, Prohibited Freq. .... 5-7  
 Rated Current, Motor .... 4-4, 5-52  
 Ratings ..... -viii-, A2-1  
 Receiving ..... 1-1  
 Reduction Level During  
   Speed Search, V/f ..... 5-34  
 Reset Codes: 2-Wire, 3-Wire  
   Initialization ..... 5-50  
**RESET** Key — *see  
 STOP/RESET Key*  
 Resistance, Motor Line-to-  
   Line ..... 5-59  
 Reverse Run Prohibit ..... A1-2  
 Ride-thru Method, Momen-  
   tary Power Loss ..... 5-26  
 Ride-thru Time, Power Loss .. 5-26  
 Rotation Direction ..... A1-1  
**RUN** Key ..... 4-1  
 Running :  
   Forward ..... 2-3  
   Reverse ..... 2-3

### - S -

Sample/Hold Function ..... 5-37  
   Freq. Ref. Retention for .... 5-18  
 S-Curve Selection ..... 5-4  
 Shock Resistance — *see  
 S-Curve*  
 Skip Frequency — *see  
 Prohibited Frequency*  
 Slave Address, Modbus ..... 5-23  
 Slip Compensation ..... 5-51  
 Soft Start — *see S-Curve*  
 Spare Parts ..... A4-1  
 Specifications ..... A2-1  
 Speed :  
   Agree ..... 5-42  
   Range ..... A2-1  
   Search ..... 5-34

**INDEX – Continued**

Speed Search Level ..... 5-34

Stall Prevention :

During Decel ..... 5-53

Level At Set Speed ..... 5-54

Level During Accel ..... 5-53

Start-up, Initial ..... 2-1

Start-up Procedure,

Simplified ..... -i-

Step Voltage, Tuning at

100% Output Voltage

(Energy Saving) ..... 5-11

Step Voltage, Tuning at

5% Output Voltage

(Energy Saving) ..... 5-11

Stop Method at Comm.

Error, Modbus ..... A1-13

Stop Method Sel. (OH1) ..... A1-5

Stopping :

Fast Stop ..... 5-29

Stopping Method ..... 5-55

**STOP/RESET** Key ..... 4-1

Switching Frequency — *see*

*Carrier Frequency*

**- T -**

Temperature :

Ambient ..... 1-1, A2-3

Storage ..... A2-3

Terminals :

Description ..... 1-3, 1-5, 1-9

Functions ..... 1-5, 1-9

Screw Sizes ..... 1-3

Thermal Overload Protection ..... 5-57

Time of Average kW

(Energy Saving) ..... A1-13

Time Over Detection,

Modbus ..... A1-13

Torque :

Compensation Gain ..... 5-59

Detection, (Over/Under) .... 5-43

V/f Pattern Setting ..... 5-60

Troubleshooting ..... 6-5

Tuning, Energy Saving ..... 5-12

**- U -**

U-xx Parameters (Monitor

Displays) ..... 4-6

Up/Down Function, Freq.

Ref. Retention for ..... 5-18

Upper Limit, Freq. Ref. .... 5-17

"Up Arrow" Key ..... 4-1

**- V -**

V/f During Speed Search ..... 5-35

**V / F** Function LED ..... 4-2, 4-3

V/f Pattern Selection ..... 5-60

Voltage :

Input ..... 5-61, A2-1

Max. .... 5-61

Mid. Frequency ..... 5-61

Motor Rated ..... 5-61

Voltage Limit of Tuning

(Energy Saving) ..... 5-12

Voltage Lower Limit at 6Hz

(Energy Saving) ..... 5-12

Voltage Lower Limit at 60Hz

(Energy Saving) ..... 5-12

**- W -**

Weight ..... A5-1

Wiring :

3-Wire Control ..... 1-8, 1-17

Control Circuit ..... 1-8

Diagrams ..... 1-15, 1-17

Distances ..... 1-2, 1-8

Main Circuit Input/Output .... 1-2

# Technical Training

# Technical Training



It is important to Yaskawa that users of our products have a totally satisfying ownership experience.

Training is one of the most effective ways to ensure that satisfaction. Because of this conviction, Yaskawa has operated a full-time professional training department since 1965.

Yaskawa trainers are full-time instructors, with a wealth of "real-life" product experience gained through field service at customer facilities. This experience, combined with backgrounds in engineering and education, has earned national recognition for Yaskawa's technical training programs.

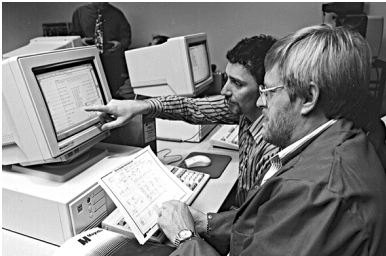

Courses are conducted at the headquarters training facility, in selected cities, and at customer sites. Courses are available to cover all the issues of

concern to product users: application, theory of operation, troubleshooting and repair, adjustment and startup, operation, programming, network communication, and optimizing the functions of Yaskawa drives.

We work hard to make all of our products user-friendly, and our owner manuals easy to use. In spite of that, the simple fact is that you will learn better and faster in a class environment combined with hands-on practice, than by self-teaching when under the stress of a maintenance or operations problem.

### On-Site Training and Customized Courses

Training courses are also provided at the user's site. Course content can be customized to the specific installation and application if requested. For further information about on-site training and courses specific to your installation and application, log on to our web site, [www.drives.com](http://www.drives.com), fax this completed form, call us at 1-800-YASKAWA, or e-mail us at [training@yaskawa.com](mailto:training@yaskawa.com).

Please send training information on:

Name \_\_\_\_\_

Position/Title \_\_\_\_\_

Company \_\_\_\_\_

Address \_\_\_\_\_

City \_\_\_\_\_ State \_\_\_\_\_ Zip \_\_\_\_\_

Phone \_\_\_\_\_

Fax \_\_\_\_\_

Yaskawa Representative (if known): \_\_\_\_\_

Fax this form to (847) 887-7185

# GPD 506/P5



## YASKAWA ELECTRIC AMERICA, INC.

Drives Division  
16555 W. Ryerson Rd., New Berlin, WI 53151, U.S.A.  
Phone: (800) YASKAWA (800-927-5292) Fax: (262) 782-3418  
Internet: <http://www.drives.com>

## YASKAWA ELECTRIC AMERICA, INC.

Chicago-Corporate Headquarters  
2121 Norman Drive South, Waukegan, IL 60085, U.S.A.  
Phone: (800) YASKAWA (800-927-5292) Fax: (847) 887-7310  
Internet: <http://www.yaskawa.com>

## MOTOMAN INC.

805 Liberty Lane, West Carrollton, OH 45449, U.S.A.  
Phone: (937) 847-6200 Fax: (937) 847-6277  
Internet: <http://www.motoman.com>

## YASKAWA ELECTRIC CORPORATION

New Pier Takeshiba South Tower, 1-16-1, Kaigan, Minatoku, Tokyo, 105-0022, Japan  
Phone: 81-3-5402-4511 Fax: 81-3-5402-4580  
Internet: <http://www.yaskawa.co.jp>

## YASKAWA ELETRICO DO BRASIL COMERCIO LTDA.

Avenida Fagundes Filho, 620 Bairro Saude Sao Paulo-SP, Brasil CEP: 04304-000  
Phone: 55-11-5071-2552 Fax: 55-11-5581-8795  
Internet: <http://www.yaskawa.com.br>

## YASKAWA ELECTRIC EUROPE GmbH

Am Kronberger Hang 2, 65824 Schwalbach, Germany  
Phone: 49-6196-569-300 Fax: 49-6196-888-301

## MOTOMAN ROBOTICS AB

Box 504 S38525, Torsas, Sweden  
Phone: 46-486-48800 Fax: 46-486-41410

## MOTOMAN ROBOTEC GmbH

Kammerfeldstrabe 1, 85391 Allershausen, Germany  
Phone: 49-8166-900 Fax: 49-8166-9039

## YASKAWA ELECTRIC UK LTD.

1 Hunt Hill Orchardton Woods Cumbernauld, G68 9LF, Scotland, United Kingdom  
Phone: 44-12-3673-5000 Fax: 44-12-3645-8182

## YASKAWA ELECTRIC KOREA CORPORATION

Paik Nam Bldg. 901 188-3, 1-Ga Euljiro, Joong-Gu, Seoul, Korea  
Phone: 82-2-776-7844 Fax: 82-2-753-2639

## YASKAWA ELECTRIC (SINGAPORE) PTE. LTD.

Head Office: 151 Lorong Chuan, #04-01, New Tech Park Singapore 556741, SINGAPORE  
Phone: 65-282-3003 Fax: 65-289-3003

## TAIPEI OFFICE (AND YATEC ENGINEERING CORPORATION)

10F 146 Sung Chiang Road, Taipei, Taiwan  
Phone: 886-2-2563-0010 Fax: 886-2-2567-4677

## YASKAWA JASON (HK) COMPANY LIMITED

Rm. 2909-10, Hong Kong Plaza, 186-191 Connaught Road West, Hong Kong  
Phone: 852-2803-2385 Fax: 852-2547-5773

## BEIJING OFFICE

Room No. 301 Office Building of Beijing International Club,  
21 Jianguomanwai Avenue, Beijing 100020, China  
Phone: 86-10-6532-1850 Fax: 86-10-6532-1851

## SHANGHAI OFFICE

27 Hui He Road Shanghai 200437 China  
Phone: 86-21-6553-6600 Fax: 86-21-6531-4242

## SHANGHAI YASKAWA-TONJI M & E CO., LTD.

27 Hui He Road Shanghai 200437 China  
Phone: 86-21-6533-2828 Fax: 86-21-6553-6677

## BEIJING YASKAWA BEIKE AUTOMATION ENGINEERING CO., LTD.

30 Xue Yuan Road, Haidian, Beijing 100083 China  
Phone: 86-10-6232-9943 Fax: 86-10-6234-5002

## SHOUGANG MOTOMAN ROBOT CO., LTD.

7, Yongchang-North Street, Beijing Economic & Technological Development Area,  
Beijing 100076 China  
Phone: 86-10-6788-0551 Fax: 86-10-6788-2878

## YEA, TAICHUNG OFFICE IN TAIWAN

B1, 6F, No.51, Section 2, Kung-Yi Road, Taichung City, Taiwan, R.O.C.  
Phone: 886-4-2320-2227 Fax: 886-4-2320-2239

This manual is available in French Canadian language. The manual number is TM4506FC. It may be printed from CD ROM (CD4005) or from the website [www.drives.com](http://www.drives.com). It may also be obtained by phone request at 1-800-854-4124.

**Document Number: TM4506 (Supercedes YEA-TOA-S616-12D) 9/01/02 Software Version: 5110, 5120, 5130**

Data Subject to change without notice. Yaskawa Electric America, Inc.