

# Instrument and Compressor Control Systems

*altronic*



# Altronic Instrumentation and Compressor Control Products

## CONTENTS

### Altronic Instrumentation and Compressor Control Overview

An introduction to Altronic's design and application philosophy .....	3
---	---

### Annunciators and Compressor Controllers

DD-NT Digital Safety Shutdown Annunciator .....	4
DD-40NTV Digital Annunciator with Advanced Features and Communications.....	4
DD-1500 System for Safety Shutdown, Monitoring, Compressor Control and Communication .....	5
DE-3000 System for Safety Shutdown, Monitoring, Compressor Control and Communication .....	6-7
Altronic Exacta21 System for Comprehensive Engine/Compressor Automation .....	8-9

### Speed/Hours/Timing Indication Instrumentation

DTH01201/3201 Universal Speed Monitoring Instruments with Hourmeter and Overspeed .....	10
DH-100A Digital Hourmeter.....	10
DSG-1201 Digital Setpoint Gauge — Speed.....	11
DSG-1401 Digital Setpoint Gauge — Ignition Timing.....	11
DO-3300/3300A Digital Speed Switches .....	11

### Temperature/Pressure/Vibration Instrumentation

45PHL Pressure Switch-Gauge with Low/High Setpoints .....	12
DPS-1591 Digital Pressure Gauge with Dual Setpoints.....	13
DPYH-1300U Series Universal Temperature Sensing Instruments (Pyrometers).....	14
DSG-1611DUPS/1682DUPS/1692DUS Digital/Bar-Graph Setpoint Gauges for Pressure, Temperature, Vibration and other Variables.....	14
DPY-4118U-A Digital Pyrometer.....	15
DPYH-4300U Series Universal Temperature Sensing Instruments (Pyrometers).....	15
DSM-43900DUS-Series Digital Setpoint Monitors for Temperatures.....	16
DSM-4600DUS-Series Digital Setpoint Monitors for Pressure, Temperature, and other Analog Parameters .....	16
ETM-40 Universal Temperature Monitor/Scanner with ModBus Communications .....	17
DET-1600/1620 Detonation Sensing Monitor .....	18
VSM Vibration Sensing Monitor .....	19

### End Devices

GSV-Series Gas Shutoff Valve .....	20
LLS-Series Liquid Level Switch .....	20

### Instrument Accessories

Pickups, Transducers, Barriers, Enclosures.....	21
---	----

### Altronic Controls, Inc.

Facilities, Capabilities, and Typical Control Panels .....	22-23
--	-------

Note: Please see Altronic Ignition Systems and Engine Controls catalogs for information on Altronic air/fuel ratio, fuel control and speed control products.

# Altronic Instrumentation and Application Philosophy

Altronic has been a preferred provider of high-quality, digital instrumentation, control, and safety/shutdown systems to the energy producing industries for more than 25 years. From design and field testing, to integrated manufacturing and internal quality control systems, Altronic instruments and controls are engineered and constructed to meet the industry demand for reliable service and performance on an around-the-clock basis.

To address the rigorous operational and environmental requirements of the oil and gas marketplace, Altronic designs and builds all of its products to insure extended, trouble-free service under the most demanding conditions. Dedicated devices, built and continually updated to meet specific application requirements such as annunciation, temperature and pressure monitoring, and speed sensing, offer users a number of operational advantages over competitive products and approaches including:

## Hardware availability and continuity

Unlike many products produced for less-demanding industrial applications, including PLCs (programmable logic controllers), Altronic instruments are built and supported over extended periods of time. For operators of critical equipment, including compressors, generators, and pumps, this assures access to spare parts and/or backward compatible enhanced designs well into the future.

## Designed for difficult and hazardous environments

Service in the oil and gas industries brings with it a unique set of challenges, including excessive temperature, exposure to RFI (radio frequency interference), and corrosive elements (moisture, salt spray, and H<sub>2</sub>S-hydrogen sulfide gas). Altronic products are built to survive in these conditions and to provide extended, trouble-free service. Most Altronic products are certified by the Canadian Standards Association as safe for use in hazardous areas.

## Support

In addition to direct support from the factory, Altronic products are supported by a worldwide network of factory-trained Distributor service technicians. Easily accessible documentation is available to the end user via [altronicinc.com](http://altronicinc.com). Altronic instrument products are also supported in most cases by both informed controls technicians and operations personnel.

## Dedication to the oil and gas industry

Altronic has spent the last twenty-five years designing and refining instrument products specifically to meet the needs of the oil and gas industries. Unlike many other instrument manufacturers, Altronic does not attempt to bring products manufactured for industrial applications into demanding oilfield service. As a result, Altronic instrument products have earned a reputation within the petroleum industries for reliability and serviceability that is unmatched by its peers.



### CERTIFIED FOR USE IN HAZARDOUS LOCATIONS

NOTE: Most, but not all, Altronic digital instruments and controls in this catalog are CSA certified and compliant with the appropriate CE/ATEX regulations. Check each product listing for certification and hazardous area classification.

# Annunciators and Compressor Controls

## DD-NT Digital Annunciator Systems

Patented DD-NT annunciator systems, available in 20- and 40-point models, continuously monitor and protect gas compressors, generators, pumps, and other types of critical equipment. These solid-state systems scan the connected electrical contacts which may represent limits on functions such as pressure, temperature, level, etc. The first-out cause of fault is displayed and remembered to aid in troubleshooting and to minimize downtime. Designed to replace mechanical indicators, relays, and pneumatic flags, the CSA-certified DD-NT systems indicate operating mode and specific cause of fault. They can monitor for out-of-bounds conditions prior to startup, and have a built-in class B bypass timer and on-board sensor test capability.



- Front panel-mounted class B start-up timer adjustment switch
- Redundant, long-life, field-replaceable lithium batteries
- Transient-protected sensor inputs can withstand momentary contact with ignition primary leads or other high-voltage sources
- One common logic unit (display) connects to either a Division 1 or Division 2 power supply
- Quick-disconnect terminal strip assemblies for sensor and power connections

## DD-40NTV Series Digital Annunciator with Advanced Features and Communications US Patent 6,738,244

The latest version of the industry-standard annunciator, the DD-40NTV series monitors up to 40 electrical contacts that represent limits on critical operating parameters such as engine or process pressures, temperatures, levels, etc. Upon detection of a fault from one of the monitored points, the annunciator displays the corresponding 2-digit fault code for that point and generates an output signal (typically to close a fuel valve and ground the ignition).



The DD-40NTV annunciator offers integral tachometer and hourmeter functions as well as overspeed protection adjustable from the front keypad. Other features carried over from the prior DD-NTS series include four configuration templates (two of these simulate the older DD-NT 20 and 40 point models), two programmed timers for class B points and a programmable delay of the second shutdown output after fault detection. The annunciator continues logic operation on the internal battery in the event the power becomes disconnected or fails.

The DD-40NTV series also provides a ModBus compatible, RS-232/RS-485 serial communications interface for connection to an RTU or PLC. New features in the NTV version when used with power

supply 691200-3 include readout of ignition, DC and internal battery voltages and pre-lube and post-lube functions.

A sealed membrane keypad and powder-coated aluminum enclosure ensure maximum reliability in harsh and hazardous environments. The DD-40NTV series annunciators are certified by Canadian Standards Association (CSA) as suitable for use in Class 1, Division 2, Groups C and D areas.

- Monitors up to 40 electrical contacts for fault
- On-board tachometer/hourmeter/overspeed
- Displays ignition, DC, and battery voltages
- User adjustable pre/post-lube
- Supports RS-232/485 ModBus RTU communications

*NOTE: The DD-40NTV annunciator may also be used with the 691200-1 Power Supply to emulate the function of the DD-40NTS system*

# Annunciators and Compressor Controls

## DE-1500 Universal Process Loop Controller

The Altronic DE-1500 Universal Process Loop Controller is designed to control virtually any engine, compressor, or industrial process. Using both digital and analog inputs for parameters such as speed, temperature, and pressure, this configurable control can use one or both of its independent PID outputs to dynamically adjust a process(es) to maintain a specified setpoint.

Among the many applications for the DE-1500 is as a suction controller for compressors in gas production or processing service. Continuously monitoring the compressor suction pressure, the DE-1500 can be configured to throttle the gas pressure control valve either directly or via an interposing I/P converter. Similarly, critical temperatures could also be monitored and maintained via an input

thermocouple or temperature transducer, with one of the DE-1500 PID outputs controlling a compressor fin-fan or other cooling device. The DE-1500 can also send a speed setpoint to a suitable governor or control device (such as the Altronic GOV10) for RPM control of the compressor prime mover (engine or electric motor).



For operators seeking independent control and safety shutdown protection, the DE-1500 can be easily combined with other Altronic products, including the DD-40NTS digital annunciator. To facilitate integration with supervisory monitoring and control systems, the DE-1500 fully supports the ModBus RTU

communications protocol. A full-featured PC-based monitoring and control software package is included with each DE-1500 system.

- Universal, two-loop controller designed to control and monitor engines, compressors, or industrial processes
- Cost-effective alternative to pneumatic suction controllers and expensive electronic controls
- 2 independent PID loops, 2 pulsed outputs, and 8 digital outputs available for control functions
- Directly accepts 4 digital and 8 analog inputs (thermocouple and/or 0-5VDC transducers plus 1 RPM)
- ModBus RTU communications standard
- Easily configurable via included Windows™-based terminal program

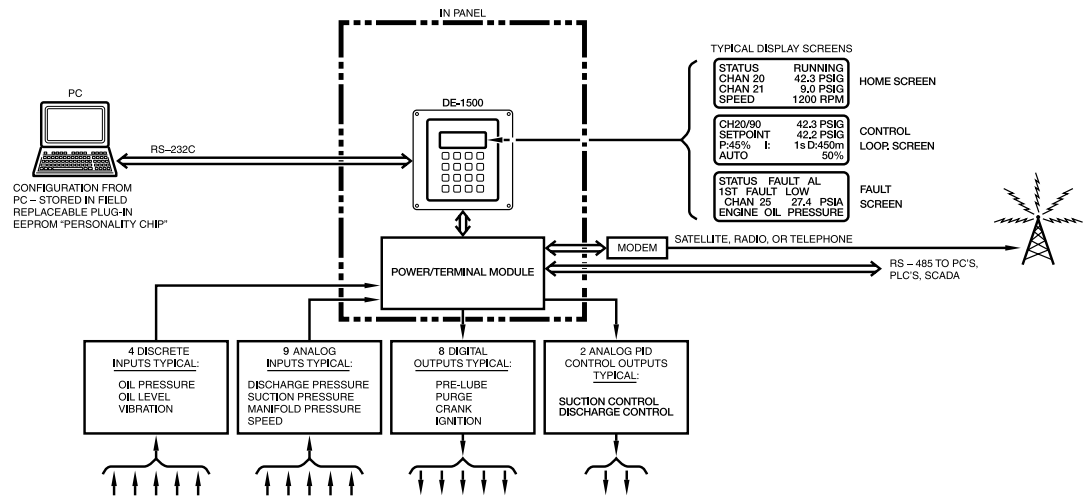
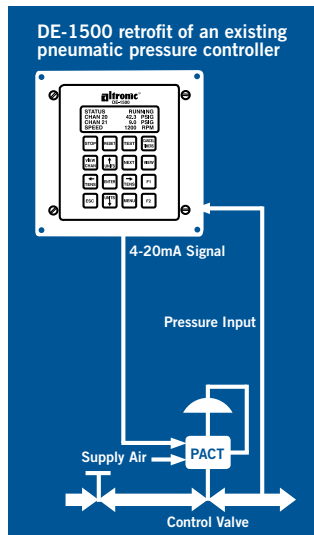

# Annunciators and Compressor Controls

## DE Series Safety Shutdown, Monitoring, Compressor Control and Communications System

These innovative, CSA-certified systems introduce a level of capability and functionality well-beyond standard, two-digit safety-shutdown annunciator devices. DE-3000, the latest version of the series, can provide up to 62 inputs and 24 outputs.

Designed with state-of-the-art micro-controller technology, the DE Series is engineered and manufactured to protect, monitor, and control critical rotating machinery such as engine or motor-driven compressors, pumps, and generators. All DE devices directly accept both digital and analog inputs and continuously monitor those inputs for out-of-bounds operation or fault indication. Depending on configuration, when an upset condition is detected, the DE system can shut down the machine using a discrete output or by shorting the ignition system and/or tripping a fuel shutoff valve on a natural gas-fueled engine. DE-3000 and DE-2500 also incorporate a sophisticated closed-loop compressor capacity control capability as well as automatic start functionality.

DE systems are suitable for retrofit applications or as the core product in a new control panel. System Power and Terminal Input Modules are typically DIN-rail mounted within the enclosure for maximum installation flexibility. The Display Module (common to all systems) provides access via the on-board sealed membrane keypad. A large, 4X20 character display offers a digital indication of monitored

values (such as process pressures and temperatures), and a unique process screen showing a group of related values in a bar-graph format. Integral speed indication (with overspeed protection) and 11 individually adjustable service meters are resident in each DE system to ensure the timely indication of associated unit maintenance requirements.

Integral ModBus RTU and ASCII communications allow direct remote access to system operating conditions, unit speed, operating hours, and other parameters via satellite, radio, cellular, or land-line communications. Local setup and system monitoring requires an included proprietary Altronic DE Terminal Software Package. Should it be required, DE systems can also be conveniently replaced in the field by simply removing the system memory module and installing it into a second device – effectively eliminating the inconvenience and cost associated with system reprogramming. Up to 100 time and date-stamped system datalogs are retained in the system memory to allow for effective application monitoring and troubleshooting.



# Annunciators and Compressor Controls

## DE-3000 Expanded Safety Shutdown, Monitoring, and Compressor Throughput Control System

- Expandable and scalable DE-3000 system is built-upon the field-proven DE-2500 for engine safety shutdown and control on both screw and high-spec reciprocating compressor applications
- Each DE-3000 input is individually configurable for:
  - Sensor Type: Analog transducer input, thermocouple input (type J or K), digital (switch input)
  - Sensor Class: A, B, or C logic
  - Digital Input Sensor Run/Fault Status: N/O or N/C
- For applications requiring additional input or control functionality, two Terminal Input Boards can be used in the DE-3000 system

## Typical Display Screens

### Home Screen

STATUS	RUNNING
SPEED	1002 RPM
SUCTION	101.5 PSIA
DISCHARGE	300 PSIG

### Process Digital

Ps	SUCTION	600	PSI
Pi 1	INTSTG1	850	PSI
Pi 2	INTSTG2	1100	PSI
Pd	DISCHRG	1200	PSI

### Process Bar Graph

SUCTION L		H
DISCHRG		H
OIL TEMP L		H
ENG MAN L		H

	TERMINAL BOARDS	DISCRETE INPUTS	ANALOG INPUTS	FREQUENCY (SPEED) INPUTS	DIGITAL OUTPUTS	ANALOG P.I.D. OUTPUTS
Option 1 DE-2200	1	16	14**	1	12	0
Option 2 DE-2500	1	16	14**	1	12	2
Option 3 DE-3000	1	30 configurable*		1	12	2
Option 4 DE-3000	2	45 configurable*		2	16	4
Option 5 DE-3000	2	60 configurable*		2	20	4

NOTE: All versions use DE-3000 Display Module.

\* All inputs are configurable for discrete, analog or thermocouple input.

\*\* 7 of 14 inputs can be configured for either analog or thermocouple input.

*NOTE: The DE-3000 Display Module may also be used with the 691136-1 Terminal Board to emulate the function of the DE-2200, or with the 691127-1 Terminal Board to emulate the function of the DE-2500*

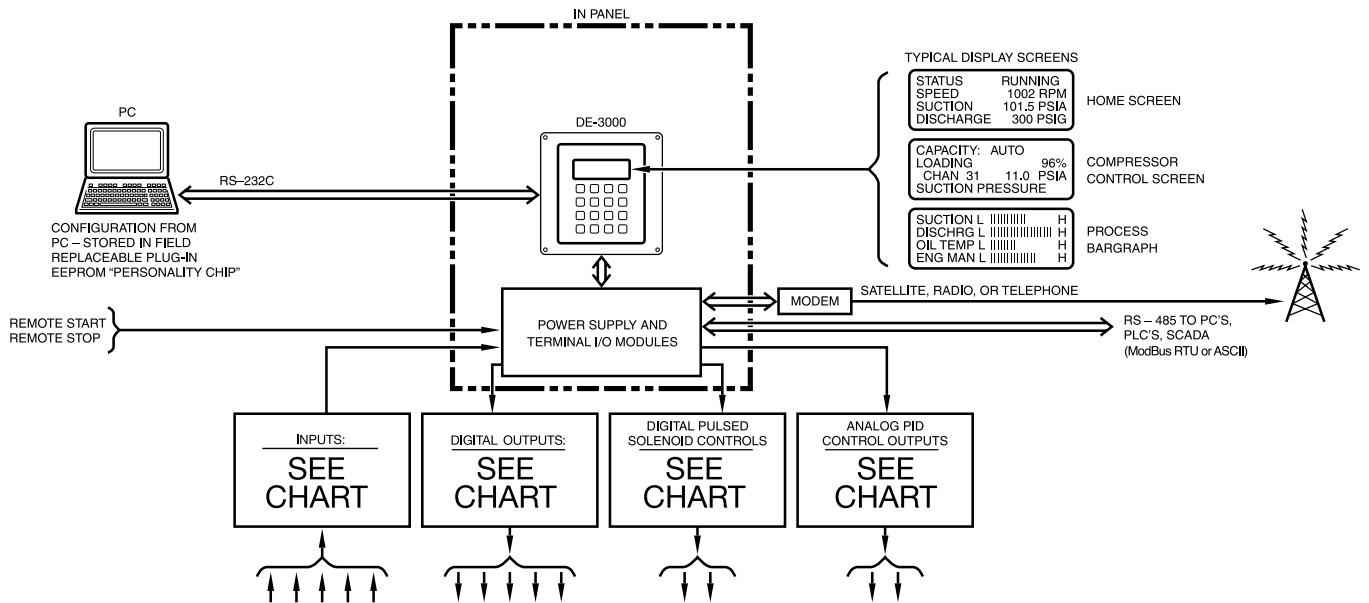

# Annunciators and Compressor Controls

## Exacta21 System for Comprehensive Engine/Compressor Automation

The Exacta21 is an “all-in-one” preprogrammed system, dedicated to monitor-



ing, controlling, and optimizing gas compressors and associated site equipment. It is focused on comprehensive, high spec control and monitoring applications (often managed by PLCs



or other high-end controls) where its processing power and large number of inputs and outputs are

required. The Exacta21 differs from most PLCs however, in that it accommodates configuration revisions directly from the keypad or via a standard PC, and the application core (where the design continuity is governed by a manufacturer and not an individual programmer) of the configuration programs are the same from unit to unit. The Exacta21 offers significant enhancements over prior models, including surface-mount construction and conformal coating of electronic components, reduced board size, DIN rail mounting, and a fully integrated power supply.

### Input/Output Capacity and Flexibility

Using “Smart” Analog and Discrete Input/Output Boards, the Exacta21 is capable of monitoring up to 192 signals including temperature, pressure, level, and others. 4-20mA-based inputs, as well as 0-5VDC

transducers, Type J and K thermocouples, switched digital inputs, RTDs, and resistive inputs are all compatible with the system, giving the user complete application flexibility.

### Shutdowns, Annunciation & Monitoring

The first—and most critical—responsibility of the system is to ensure the safe operation of the engine and compressor. An unlimited number of shutdown and alarm setpoints can be added to any channel, including the normal high and low values plus differentials, “calculated shutdowns”, time delayed shutdown points, and for out-of-range data values. The “First-out-fault” is annunciated in the display, and the preconfigured actions (shutdown and/or alarm) are executed automatically to maintain the safety of the unit and personnel.

### Start/Stop and Capacity Control

Each Exacta21 system can perform full startup, load, unload, and shutdown functions, including pre-lube, purge, crank, warm-up, and post-lube. Full capacity control (load) is accomplished by adjusting up to 15 PID control loops, making the system suitable for both reciprocating and screw compressors.

### Data Capture

To aid in long-term monitoring and analysis, the Exacta21 Controller automatically records all of the monitored temperature, pressures, and other analog inputs at regular intervals, storing up to 1,400 records in its memory. For enhanced troubleshooting, the Exacta21 records 40 records of data, taken at one second

intervals prior to shutdown and can also store up to 40 separate shutdowns.

### Communications

Designed for operation in a “serial environment”, the Exacta21 has built-in RS232 and RS485/422 ports for communication. External connections to supervisory control or communication systems (including station controls and SCADA systems) are accomplished via ModBus RTU protocol.

### Programming

Combining the flexibility of a PLC with the programming ease of a dedicated, purpose-built controller, the Exacta21 uses object-oriented programming to configure the system for operation. Capable of addressing both simple and complex control protocols, virtually all compressor control functions are capable of automation, including shutdown, alarm, pre-tube, post-lube, start/stop, and load management.

### Hazardous Area Approval

Unlike many industrial PLC controls, the Exacta21 system is CSA certified for use in Class I, Division 2, Group C and D areas. This eliminates the need for expensive local approvals, explosion-proof enclosures, and maintenance-intensive purging systems.

*NOTE: Although the Altronic Exacta21 System replaces the Exacta Series XI Monitoring and Control System, parts and service for the Series XI will continue to be available*



# Annunciators and Compressor Controls

## Why an Exacta21?

The innovative Exacta21 System offers users a stable hardware and application platform that will be manufactured and supported in the long term, and a highly expandable and flexible monitoring and control platform capable of servicing even the most demanding, control-intensive applications. While protected by a tiered security system insuring controlled access, this approach also gives the user the ability to make operational changes from the keypad without additional hardware and/or software, and without a detailed knowledge of ladder logic. Taken together, these capabilities offer flexibility, serviceability, and expandability for virtually any gas compressor application.

- Application stability — both the hardware and embedded application are based on a repeatable engineering and manufacturing standard
- User and field configurable (password protected) with no knowledge of ladder logic or other programming languages required
- Long-term access to field and factory-based technical support
- Robust hardware specifically designed for use in hazardous areas
- Upgrade and service parts available from Altronic Distributors worldwide
- On-board security and tracking for improved revision and parameter adjustment control

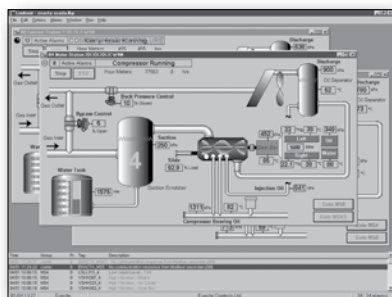
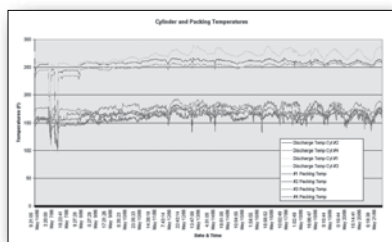
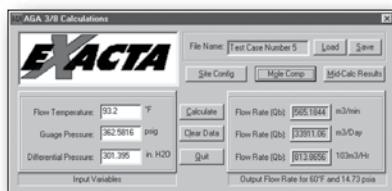
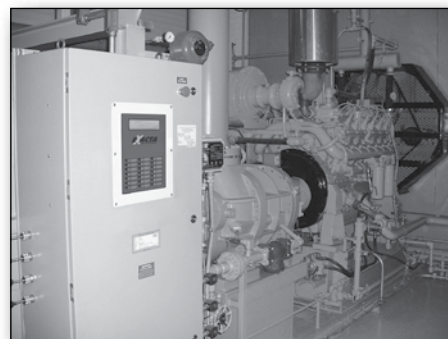

## Control Panel Software

Accessible from a standard PC running HyperTerminal™ or other inexpensive communication software, it displays a combination of analog inputs, shutdowns, alarms, recorded history and events monitored by the Exacta21 System.

## AGA 3 and AGA 8 Flow Calculations

The Altronic Exacta21 is capable of performing both AGA 3 and AGA 8 gas flow calculations, with up to five calculations performed simultaneously.

## Program Revision Tracking

The Program Revision Tracking System is available as an option and offers the ability to automatically record any changes to system configuration. This is an ideal tool for configuration monitoring and accountability.

## Data Capture and Trending

Using the data logging system within the Exacta21, the system is capable of downloading the monitored data to a PC-based spreadsheet and statistical analysis software package for trending and performance analysis.

## Optional Graphical User Interface

Remote monitoring and control of the Exacta21 system can be enhanced through the addition of a graphical user interface (GUI), such as the package shown here.

# Speed/Hours/Timing Indication Instrumentation

## DTHO-1201/3201 Universal Speed Monitoring Instruments with Hourmeter and Overspeed

These digital tachometers are designed for universal use. They are high-quality, microprocessor-based devices that can be powered from either a C.D. ignition “shut-down lead” or a magnetic pickup, and are offered in two durable Lexan enclosures for use on natural gas engines and other critical rotating equipment. Both models include overspeed trip and hourmeter functions.

**DTHO-1201** features a weather resistant 4-1/2" round case which can be mounted in an industry-standard cutout. It replaces the DT/DTH/DTO/DTHO-1200-series tachometer instruments.

**DTHO-3201** is packaged in a 4.19" X 5.00" Lexan case. It replaces DTO-1010, DT/DTH/DTO-3200 and the PT/PTH/PTO/PTHO-2100 series devices.

These highly accurate devices are simple to set up via a front-mounted, sealed membrane keypad. No calibration is required. Either device can be configured to monitor engine RPM or higher speeds of interest, including turbocharger RPM. An advanced filtering algorithm assures a stable speed readout even during periods of speed input fluctuation. Both the DTHO-1201 and 3201-series devices are CSA certified as safe for use in Class I, Divisions 1 and 2, Groups C and D hazardous areas.



### Engine or Prime Mover RPM



### Turbocharger RPM



### Operating Hours



## DH-100A Digital Hourmeter

This solid-state digital hourmeter operates directly from CD ignition systems, 8 to 440VAC or VDC, or intrinsically-safe magnetic pickups. The DH-100A is designed to withstand vibration and to give extended service in hazardous and demanding environments, eliminating the problems associated with mechanical devices. Power consumption is negligible (microamps) and the device can be applied to virtually any process. Switches on the back of the unit allow the hour count to be preset to any number, or reset to zero. When the power is disconnected, the accumulated count is retained and the readout can be obtained by depressing the button on the front of the unit.



# Speed/Hours/Timing Indication Instrumentation

## DSG-1201/1401 Digital Setpoint Gauges for Speed & Timing Indication

The DSG-series instruments are built upon a common, microprocessor-based platform and share a common set of installation and operational features. These high-level, DC-powered instruments feature a unique digital/analog display, simple user configuration via a sealed membrane keypad, multiple setpoints, Form C (N/O or N/C) output switches, are housed in a durable 4-1/2" round Lexan enclosure, and have optional 4-20mA outputs.

### DSG-1201 Digital Setpoint Gauge

Speed is designed to provide an accurate indication of speed on engines or other critical rotating equipment. The required input frequency signal can be derived from the #1 cylinder ignition coil of a CD ignition system or a magnetic pickup. Four individual setpoints and output switches can be configured for use in automation projects (start/stop, crank disconnect, fuel on/off, etc.)

### DSG-1401 Digital Setpoint Gauge

Ignition Timing offers local and/or remote indication of engine ignition timing. The device accepts a CD ignition input signal from the #1 cylinder ignition coil and a magnetic pickup input signal to precisely determine and display the timing of the ignition system. Two timing setpoints/outputs can be configured, with outputs three and four used to provide rotation-confirm and fire-confirm for engine automation projects.



## DO-3300/DO-3300A Digital Speed Switches

DO-3300 Series Digital Speed Switches operate from CD ignition systems with no other signal or power source required. Applicable to all spark-ignited engines, the trip RPM is set in 10 RPM increments by three rotary switches on the front face of the device. Two models cover most speed-related applications.

### DO-3300

General-purpose speed switch with an input voltage range of 100-400VDC. Isolated output switch turns on above setpoint, off below setpoint.

### DO-3300A

Special overspeed trip model designed for engines using ignition systems of 200VDC primary voltage or lower. Can directly short the ignition system or trip safety relay switch or pneumatic valve.

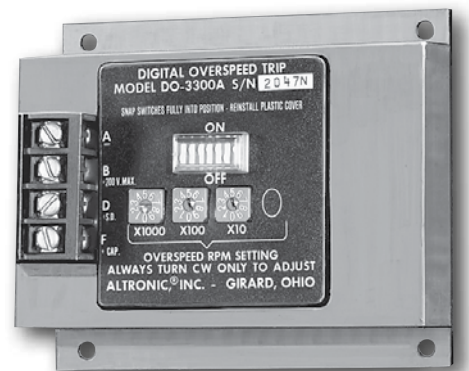

# Temperature/Pressure/Vibration Instrumentation

## 45PHL Pressure Switch-Gauge with Low/High Setpoints

The Altronic 45PHL-series pressure switch-gauges are the standard for mechanical pressure gauges with low/high switch contacts.

Incorporating the innovative “direct drive” pressure-sensing technology developed and used for precision pressure test instrumentation, the 45PHL utilizes a special, helically wound coil of Inconel to properly determine and display the monitored pressure. This approach eliminates the internal gears and linkages used in traditional bourdon-tube based gauges, as well as their associated inaccuracy and poor reliability. The 45PHL offers the user extended service life, high accuracy ( $\pm 1\%$ ), and repeatable readings across the range of application and environmental conditions. Fifteen different pressure ranges are available and are listed below.

To insure simple retrofit in the field, the 45PHL is packaged in a 4-1/2" round weather-resistant case designed to fit into industry-standard panel cutouts. The switch setpoint arrangement features two color-coded low/high setpoint adjustment knobs on the front of the gauge. The 316 stainless steel connection stem is user-adjustable in the field for bottom or back connection. For maximum corrosion resistance, the device features stainless steel components, including all rivets and screws.

This vibration-resistant gauge offers users a high-quality alternative at a moderate price to the antiquated, bourdon-tube based instruments currently in operation

throughout the world. By embracing a fundamentally superior pressure sensing technology and offering a wide variety of available gauge ranges, this product represents one of the most significant developments in control panel technology for field gas compression and processing units since Altronic released the digital annunciator in the late 1970s.

- Superior gauge movement technology yields accurate, repeatable readings
- Designed for demanding applications and in corrosive environments
- Uses an industry-standard 4-1/2" cutout for easy retrofit
- Interchangeable with OPLFC gauges

### 45PHL Pressure Ranges

Gauge Range	Part Number
-30" Hg to 30 psi	45PHL-30V30
-30" Hg to 100 psi	45PHL-30V100
0-30 psi	45PHL-30
0-60 psi	45PHL-60
0-100 psi	45PHL-100
0-160 psi	45PHL-160
0-200 psi	45PHL-200
0-300 psi	45PHL-300
0-500 psi	45PHL-500
0-600 psi	45PHL-600
0-1000 psi	45PHL-1000
0-1500 psi	45PHL-1500
0-2000 psi	45PHL-2000
0-3000 psi	45PHL-3000
0-5000 psi	45PHL-5000

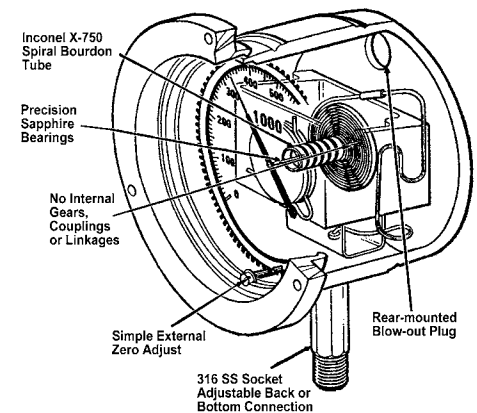

# Temperature/Pressure/Vibration Instrumentation

## DPS-1591 Digital Pressure Gauge with Dual Setpoints

The advanced, highly accurate ( $\pm 0.25\%$  of span), DPS-1591 Digital Pressure Gauge is a single point pressure monitoring device, ideal for use in monitoring process pressures. To assure maximum application flexibility, the device is designed to accept power from the same two lines used for the 4-20mA proportional current loop output. For applications not requiring the current loop, the unit can be externally powered with DC-power. Utilizing either power source, unit operation (and setpoint protection) is backed up by a very long life internal lithium 3.6-volt "C" size battery. Using this same internal battery, extended stand-alone service (4+years) can also be achieved without the application of outside power. Packaged in a standard 4-1/2" round case, the accuracy and numerous configuration options make it suitable for use in monitoring virtually any critical pressure. Eight pressure ranges are available and are listed in the chart below.

In addition to power, display, and output switch flexibility, the DPS1591 DP incorporates a number of features designed to enable its use in a wide range of applications and environments, including integral pressure transducer (with connection stem field adjustable for side or bottom mount), built from high-quality stainless steel and incorporating a media isolated sensor with no internal o-rings, silicone oil or welds. A sealed membrane keypad, and an ABS plastic case further make this gauge suitable for the measurement of gases or liquids in corrosive environments.

Featuring a large digital and bargraph display, this unique instrument gives the user access to both the actual monitored value and an indication of that reading as a percent of span between two selected points, as well as a reference to direction and amplitude of a rapid change in reading. An adjustable software filter stabilizes readings where the monitored pressure is fluctuating. The gauge also stores the highest and lowest filtered readings to which it has been exposed.

Two individually adjustable setpoints can be configured to trip on a low or high setpoint, as well as on a loss of loop. Both output switches (one per setpoint) can be configured for normally open or normally closed operation making the DPS-1591 ideal for gas compressor panel service.

- Solid-state electronic design replaces analog-style gauges
- Highly accurate,  $\pm 0.25\%$  of gauge range
- Multiple power options available, including loop power
- Large digital display and analog bargraph readout
- Utilizes an industry-standard 4-1/2" cutout for easy retrofit

### DPS-1591 Pressure Ranges:

Gauge Range	Part Number
-14.7 to 50 psig	DPS-1591DP-50
-14.7 to 100 psig	DPS-1591DP-100
-14.7 to 200 psig	DPS-1591DP-200
-15 to 500 psig	DPS-1591DP-500
-15 to 1000 psig	DPS-1591DP-1000
-15 to 2500 psig	DPS-1591DP-2500
-15 to 5000 psig	DPS-1591DP-5000
-15 to 9999 psig	DPS-1591DP-9999



# Temperature/Pressure/Vibration Instrumentation

## DPYH-1300U Series Universal Temperature Sensing Instruments (Pyrometers)

These are solid-state instruments that give a continuous temperature readout and have an alarm/shutdown capability at a user-adjusted temperature limit. These “universal” 1-, 2- and 9-point temperature



monitors are housed in durable, 4-1/2" round Lexan cases, can be configured for readout in degrees Fahrenheit or Celsius, use industry-standard type J or K thermocouples, and can operate from either 12-48VDC or CD ignition input power. The output switches integral to each unit are suitable for use with Altronic annunciators or other specified devices.



The single- and dual-point DPYH-1300U models can be used on applications ranging from engine oil and water temperatures to catalytic converter and turbocharger inlet/outlet protection. The 9-point model is designed to use channels 1 through 8 for engine cylinder exhaust temperature readings with point 0 used for turbocharger or catalytic converter monitoring.

**DPYH-1301U** monitors one point with a high-limit setpoint; it has output switches for both N.O. and N.C. operation

**DPYH-1392U** monitors two points with an individual high-limit setpoint for each channel; it has output switches for both N.O. and N.C. operation

**DPYH-1379U** monitors nine points with point 0 protected by the first high-limit setpoint, and points 1–8 protected by the second common high-limit setpoint. Both output switches are N.O.

## DSG Digital/Bar-Graph Setpoint Gauge for Pressure, Temperature, Vibration and Other Variables

These advanced gauges monitor, display and protect either one or two process variables. The DSG-1611 is a universal one-point model. The DSG-1682DUPS and DSG-1692DUS are two-point versions.

DSG gauges can be connected to either type J or K thermocouples, 0–5 volts or 0–25mA (scalable) input signals. In the DSG-1692, this choice is independent for each of the two monitored points. All three versions have a RS-485 serial port and ModBus communications with 5 selectable baud rates. Power requirement is 12–36Vdc, 0.25A maximum.



DSG gauges feature a sealed membrane keypad and a high-resolution digital readout/bar-graph display which indicates the reading as a percent of transducer span or span between high/low setpoints, with a reference to direction and amplitude of a rapid change in reading. The display also

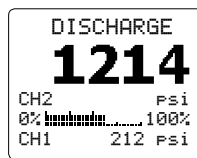
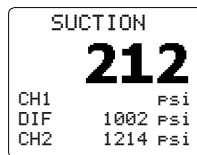

indicates the units and annunciates an alarm by number and type.

Two (one on the DSG-1682DUPS) solid-state, form C (N.O. and N.C.) output switches can each be assigned high and low setpoint values which are retained indefinitely. The precision nature of these switches allows these gauges to be used as control devices.

**DSG-1611DUPS** The single-point model has both 4–20mA proportional output and RS-485 serial communications. It replaces all prior models of the DSG-1301 and 1601 and can be programmed for both a low and high output for each of the two output switches.

**DSG-1682DUPS** This dual-channel gauge is a single-loop PID controller offering the following modes of operation:

- 4-20mA output loop vs. the channel 1 input OR channel 2 – channel 1 (differential)
- Direct or inverse PID output based on the input of channel 1 or in a “mapping” mode that allows the channel 1 PID setpoint to be modified by the monitored input of channel 2.

**DSG-1692DUS** In the standard dual-point model, each channel is independently assigned for type J or K thermocouple, 0–5 volts or 0–25mA input signals. This allows the device to be used for one temperature and one pressure or two of either type. In addition, the device can be set up with a differential setpoint between the two monitored points.

# Temperature/Pressure/Vibration Instrumentation

## DPY-4118U-A Digital Pyrometer

The intrinsically-safe, internally powered DPY 4118U-A digital pyrometer is a cost effective, accurate, and reliable alternative to traditional mechanical switch-based temperature devices and analog meters/gauges. Offering 1° resolution and 1% ±3 degrees accuracy, these precision devices can monitor up to 18 points of interest using industry-standard type J or K thermocouples. The device is powered by long-life lithium batteries with a 10-minute readout period each time the front-panel membrane switch is activated. Indication of both open thermocouples and low battery is given in the display to maintain trouble-free service. The DPY-4118U-A is housed in a gasketed, powder-coated, aluminum enclosure with stainless steel hardware, making it ideal for oilfield service or other corrosive and environmentally-demanding applications.



  
C US  
CERTIFIED  
CLASS 1  
GROUP D  
Intrinsically Safe

## DPYH-4300U Digital Pyrometers with Alarm Switch

These electronic instruments monitor temperatures using industry-standard type J or K thermocouples. Models are available with 4, 6, 8, and 20-thermocouple input channels. Readout can be configured for degrees C. or F, and the device can be powered from either 12-48VDC or a CD ignition. Most models (with the exception of the DPYH-4320U series) feature user-selectable thermocouple type (J or K) and a sealed membrane keypad.

**DPYH-4354U** monitors up to 4 separate inputs against a common setpoint. All faults trip a common output switch.

**DPYH-4394U** accepts up to 4 separate inputs, each monitored against an individually-adjustable setpoint. An individual output switch is provided for each setpoint.

**DPYH-4396U** accepts up to 6 separate inputs, each monitored against an individually-adjustable setpoint. An individual output switch is provided for each setpoint.

**DPYH-4398U** accepts up to 8 separate inputs, each monitored against an individually-adjustable setpoint. An individual output switch is provided for each setpoint.

**DPYH-4320U** monitors up to 20 thermocouples with 4 of those thermocouple input points monitored against a common setpoint. All setpoint faults trip

a common output switch. A typical application would use the device to monitor individual engine cylinder temperatures (up to 16) with a common shutdown on the turbocharger inlet or post-catalyst temperatures.

Setpoints and normally-open output switches are integral to all DPYH-4300U series systems, enabling their use in the temperature monitoring and protection role in conjunction with a digital annunciator or DC-operated relay. All DPYH-4300U series instruments are housed in rugged, anodized aluminum enclosures for maximum survivability and reliability in difficult operating environments.



  
C US  
CERTIFIED  
CLASS 1  
DIV 1 & 2  
GROUP D

# Temperature/Pressure/Vibration Instrumentation

## DSM-4390DUS-Series Digital Setpoint Monitors for Temperature

Designed specifically for monitoring temperatures on engines, compressors, and other critical applications, these devices operate on 12-30VDC power and use standard



type J or K thermocouples as inputs. All DSM-4390DUS units feature ModBus RTU communications via an integral RS-485 output.



Each of the three “universal” devices has four individual setpoints (two high and two low) per channel and two output switches. These units may be used in alarm/shutdown service or in any other configuration where the monitored points serve two functions. The monitoring capability of the device is further extended through the incorporation of a unique grouping function whereby all temperature input channels can be sorted into a single- or two-group configuration with individual group setpoints attached to each (two high, two low, and two differential).

All models feature a sealed membrane keypad and large, backlit alphanumeric display for indication of the channel number, the value of the monitored temperature, and a bar-graph showing the position of the monitored temperature between the low and high setpoints. All setup details, including thermocouple type (J or K), temperature units (F. or C.),

calibration, and individual high/low setpoint values are accessible and adjustable from the front of the device. Fault information by sequence of occurrence is available on both the unit display and via the RS-485 serial port. ModBus RTU allows for remote communications of the monitored conditions.

DSM devices are housed in a gasketed, powder-coated aluminum enclosure and assembled using stainless steel hardware, making them ideal for use in oilfield or other environmentally-challenging applications.

- DSM-43908DUS accepts up to 8 type J or K thermocouple inputs

*NOTE: This device can be configured to simulate the popular DSM-4388DUS model which it replaces. In this mode, there is one high and one low setpoint per channel, and one Form C, solid-state output switch.*

- DSM-43916DUS accepts up to 16 type J or K thermocouple inputs
- DSM-43924DUS accepts up to 24 type J or K thermocouple inputs

## DSM-4600DUS-Series Digital Setpoint Monitors for Pressures, Temperatures, and other Analog Parameters

These monitors provide cost-effective multipoint monitoring of pressures, temperatures, or other process variables on compressor packages and generator applications in a serial communications environment. The ability to monitor and display up to eight analog transducer inputs, combined with an integral RS-485 communications capability makes the

DSM-4600DUS an ideal “front end” data collection device for use with supervisory controllers such as the Altronic DE-Series systems and remote monitoring (SCADA) systems.

All models are 12–30VDC powered, and feature a sealed membrane keypad as well as a large, backlit LCD display for both the channel number and the value of the monitored variable.



All DSM devices are housed in gasketed, powder-coated aluminum enclosures and assembled using stainless steel hardware, making them ideal for oilfield or other environmentally-challenging applications.

- DSM-4688DUS accepts up to eight (8) analog transducer inputs – typically for monitoring temperatures and pressures.
- DSM-4689DUS accepts up to eight (8) analog transducer inputs for pressure, temperature, and other process monitoring, plus a discrete speed input (from a CD ignition system). An hourmeter is also provided in the unit.



# Temperature/Pressure/Vibration Instrumentation

## ETM-40US Universal Temperature Monitor/Scanner with ModBus Communications

The ETM-40US Universal Temperature Monitor/Scanner is a microprocessor-based instrument that monitors up to 40 process temperatures. While primarily designed for monitoring critical temperatures on reciprocating engines and compressors, the availability of 10-36VDC or 100-250VAC as input power options, the suitability for use with either type J or K thermocouples, and the wide variety of input and output module options allows for the application of the ETM-40US to virtually any industrial process requiring state-of-the-art temperature protection.

Each of the monitored points is arranged in one of seven temperature groups (see chart). This allows the user to group similar points (such as engine cylinder exhaust temperatures or turbocharger outlet temperatures) which can be measured against a set of common alarm, shutdown, and differential setpoints. Low and high setpoint monitoring for each channel is also available. The ability to choose between two sets of setpoints for each channel and for each group, along with the flexibility in mapping of those setpoints to individual outputs, enables the ETM-40US to be used for both alarm and shutdown annunciation.

The backlit, alphanumeric LCD display offers all of the setup and monitored information. A front panel, sealed membrane keypad provides easy selection and adjustment of the displayed units,

range, setpoints, and other configuration data. All fault information (alarm and shutdown) is available on the display in the order of occurrence, which aids in determining the origin of the fault condition. This same fault information, the monitored temperature values, and the status of all channels, can be accessed via a PC, PLC, or other supervisory control system using the ModBus RTU protocol (RS-485). System configuration and setup (including custom point labeling) is simple and accomplished by accessing the keypad on the front of the device or via the ETM-40US terminal software.

For maximum durability in demanding operating environments, the ETM-40US is housed in a gasketed, powder-coated, NEMA 4 steel enclosure and assembled using stainless steel hardware.

*NOTE: The ETM-40US is designed to physically interchange with its predecessors, the ETS-24 and ETS40 temperature scanners.*



### Normal Operating Screen

```
CHANNEL    01  950°F
GRP1 OK    AVG  943°F
1 L> ##### <H
2 L> ##### <H
```

### Fault Screen

```
CHANNEL    01 1050°F
GRP1 FT    DIF  100°F
FAULT1:    DIF
2 D> #####<
```

### ETM-40US Group/Setpoint Matrix

Group	Channel Numbers	Common Setpoints	Individual Setpoints	Outputs
1	01-XX	L1, H1, D1 L2, H2, D2	L1, H1 L2, H2	1 2
1A	XX-16	L1, H1, D1 L2, H2, D2	L1, H1 L2, H2	1 2
2	17-18	L1, H1, D1 L2, H2, D2	L1, H1 L2, H2	1 2
3	19-20	L1, H1, D1 L2, H2, D2	L1, H1 L2, H2	1 2
4	21-XX	L1, H1, D1 L2, H2, D2	L1, H1 L2, H2	1 2
5	XX-36	L1, H1, D1 L2, H2, D2	L1, H1 L2, H2	1 2
6	37-40	L1, H1, D1 L2, H2, D2	L1, H1 L2, H2	3 4

Note: Shading indicates default selection as the device is shipped.

# Temperature/Pressure/Vibration Instrumentation

## DET-1600/1620 Detonation Sensing Monitors

The Altronic DET-1600/1620 Detonation Sensing Monitors are 24VDC-powered, 32-bit microprocessor-based electronic instruments designed for use on natural gas-fueled engines to detect detonation and misfire and avoid consequential engine damage. Industry-standard, low-cost, piezoelectric vibration sensors are mounted directly on the engine and are used to transform the vibrations caused by combustion into electrical signals which are then evaluated by the DET-1600/1620. These values – generated for every cylinder on a cycle-by-cycle basis – are then measured against misfire and detonation setpoints configured by the user for the monitored engine. The monitors accept up to 16 detonation sensors wired to pluggable Phoenix-type connectors; the recommended configuration is one sensor per cylinder.

The DET system can be configured to take a number of control actions to protect the monitored engine upon indication of detonation (or misfire). In many applications, the DET will utilize one of two solid-state output switches to activate an external unloader to reduce engine load. Should that remedial action be unsuccessful addressing the detonation issue, the DET can be configured (when used in conjunction with a digital ignition system) to automatically retard the ignition timing. In the event that an ignition timing adjustment also proves to be ineffective in eliminating engine detonation, the second output switch – typically tied to

a digital annunciator or other monitoring device – acts as a final safety measure to shut down the engine.

The DET system is housed in a rugged, powder-coated, aluminum enclosure and features an integral 2x16 character backlit LCD to display the detonation and misfire reference level numbers, engine cylinder labels, control and output switch status, the cause of shutdown log, and all diagnostic messages. System configuration is accomplished using an on-board RS485 serial port and a powerful, yet easy to use, system configuration and monitoring program.

- Moderately-priced system protects natural gas-fueled engines from destructive knock/detonation
- Monitors the engine for in-cylinder misfire conditions
- Automatic load reduction and engine shutdown functionality
- Can be connected to most Altronic digital ignition systems for automatic timing retard control in the event of detonation
- Model DET-1620 for large bore, slow speed engines using Altronic's CPU-2000 ignition system



### HOME SCREEN GLOBAL SYSTEM STATUS

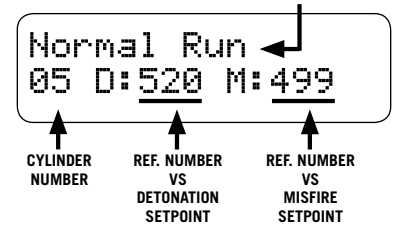

### DETONATION SENSED INDIVIDUAL CYL STATUS

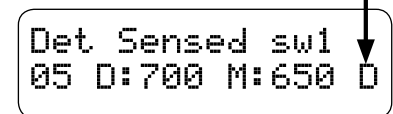

### BARGRAPH DISPLAY OF ALL CYLINDERS

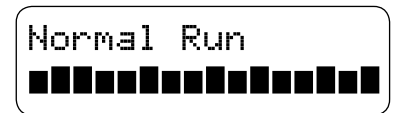

### TERMINAL PROGRAM

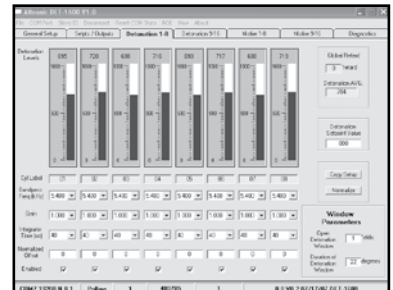

# Temperature/Pressure/Vibration Instrumentation

## VSM Vibration Sensing Monitor

The VSM is a 32-bit microprocessor-based electronic instrument designed to protect industrial engines, compressors, and associated equipment from damage caused by excessive vibration. The monitor accepts up to four (VSM-400) or eight (VSM-800) industry-standard low-cost, broadband, piezoelectric vibration sensors that are used to transform mechanical vibrations into electrical signals which are then evaluated by the VSM. The resulting vibration levels are displayed on a LCD display and are compared to user adjustable setpoint levels (2 per channel). If a high vibration level surpasses a user-configured setpoint value, an indication is shown on the LCD and an output switch — one for alarm and one for shutdown — is activated.

With each input channel operating independently of the other, the VSM can be used as the monitoring device for all of the vibration points of interest on an application. For example, individual sensors mounted on a gas compressor cooler, on each bank of the engine, and on the compressor cross-heads are individually configured for the appropriate vibration characteristics and monitored by a single VSM device. RS-485 Modbus RTU communications is resident in the device allowing the vibration data from each channel to be communicated to a control PC/PLC or remotely as a means of determining the overhaul health and well-being of the equipment. Configuration of the device can be accomplished simply and conveniently directly from the front

of the device using the system keypad or through the use of the VSM Terminal Program included with each unit.

The VSM is housed in a 6.50" x 6.50" powder-coated aluminum case for maximum durability in difficult applications. Rugged, pluggable Phoenix-type connectors are used for all input/output connections to assure long-term, reliable system service. Each VSM is also certified as safe for use in Class I, Division 2, Group C and D hazardous operating areas by the Canadian Standards Association (CSA).

- Effectively protects natural gas-fueled engines from damage due to excessive vibration
- A single VSM can monitor all major vibration points of interest on a natural gas or diesel engine, compressor (air or gas), pump, or other process
- Accepts up to 4 (VSM-400) or 8 (VSM-800) low-cost, piezoelectric vibration sensors as system inputs
- Eliminates on-engine mechanical vibration switches that are vulnerable to misapplication, setpoint tampering, and physical damage
- Includes alarm and shutdown setpoints and outputs
- Full Modbus RTU communications supported for remote monitoring



### HOME SCREEN

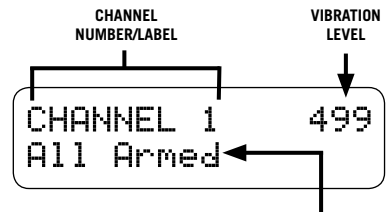

### BARGRAPH SCREEN

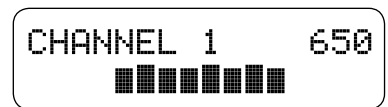

### SHUTDOWN SETPOINT SCREEN

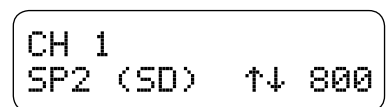

# End Devices

## GSV-Series Gas Shutoff Valve

The GSV-series Gas Shutoff Valve automatically interrupts the flow of fuel in the event that an engine or process fault is detected by a supervisory safety shutdown system such as the Altronic DD- or DE-series annunciator/controllers.

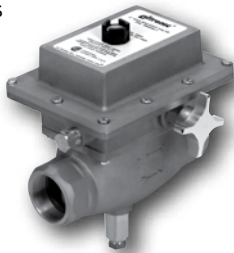

Two models are available:

**CD IGNITION POWERED** is opened manually, is held open mechanically, and draws no electrical power. The valve closes when its internal coil is energized by a pulse from a shutdown system.

**12–24 VDC POWERED (FAILSAFE)** is opened manually and held open electro-mechanically. It uses a voltage regulator circuit to keep current draw independent of the DC voltage applied and to a low 0.2 amps maximum in the energized (open) mode. The valve closes when its internal coil is de-energized by a shutdown system.

An external indicator shows whether the valve is open or closed. The valve has a positive closure and vents gasses after shutdown. Mounted on the top of the valve body, this indicator button can also be used as a manual stop to close the valve and stop the flow of fuel to the engine. An internal micro-switch which actuates on shutoff can be used for remote indication of fuel status or for other purposes.

The GSV can be safely used in hazardous areas with suitably approved safety shutdown and control systems, including all Altronic annunciators. The GSV features an industry-standard body size and thread specifications, and can be used as a replacement for existing gas shutoff valves, such as the M50.

- Two models; 2" NPT
  - CD ignition powered (690040-1)
  - 12–24 VDC powered (690045-1)
- Simple, direct-acting valve latching mechanism for improved reliability and extended service
- Unique, highly-visible valve position indicator/manual stop button
- Directly replaces traditional gas shutoff valves, including M50

## LLS-SERIES LIQUID LEVEL SWITCH

The Altronic LLS represents the next generation in liquid level protection for gas compressor scrubbing and dehydration units as well as other applications. Featuring a unique isolated cavity for the electrical switch and wiring, the design of the LLS eliminates the possibility of leakage and liquid contamination of the electrical switch and connections— the leading cause of premature failure of similar float switches currently in service.



This high-quality, all stainless-steel, float-activated design is equipped with

a 2" NPT threaded connection for direct installation into the wall of the pressure vessel or weld collar or can be adapted for use in conjunction with an external float chamber. As condensate or other liquids rise or fall within the monitored vessel (scrubber), the float/arm assembly on the “wet” side of the LLS deflects and moves an arm, causing the single pole, double-throw micro-switch in the “dry” side to trip. The connection between the two cavities is a magnetic field and requires no ports or wiring orifices. Both low and high level monitoring applications can be accommodated through the use of the appropriate micro-switch contacts within the device.

The Altronic LLS Level Switch is designed as an explosion-proof device and is certified by CSA for use in Class 1, Division 1 and 2, Groups C and D hazardous areas. Designed to meet industry-standard mounting and installation specifications (body size and threads), the LLS can be used as a replacement for existing single-cavity designs, including the L1200.

- High/low liquid level protection for gas compressors and other applications
- Dual chamber design delivers better long-term service and reliability
- All stainless-steel construction for superior corrosion resistance
- Directly replaces traditional liquid level switches

# Instrument Accessories

## Altronic Magnetic Pickups

Altronic magnetic pickups (691118-X) are high-sensitivity designs and are intrinsically-safe for use in Class I, Division 1, Groups A, B, C, and D hazardous areas. The table below represents available pickup lengths.

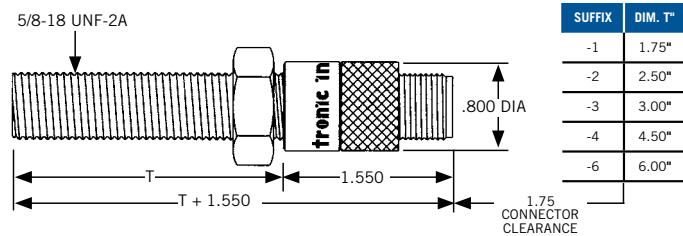

## Altronic Pressure and Temperature Transducers

A comprehensive line of moderately priced, yet high quality pressure transducers complements the Altronic line of controllers and monitoring instruments. A variety of pressure ranges are available, with both psia and psig configurations available.

A unique series of proprietary temperature transducers is also available. These devices are manufactured in two ranges: +5°F to 350°F (-15°C to 176°C) and -40°F to 450°F (-40°C to 232°C) and are ideal for monitoring process gas temperatures. The use of temperature transducers also enables the use of the same monitoring devices used for monitoring pressures and other analog inputs, such as the DSM-4688/4689DUS and the DSG-1601DU.

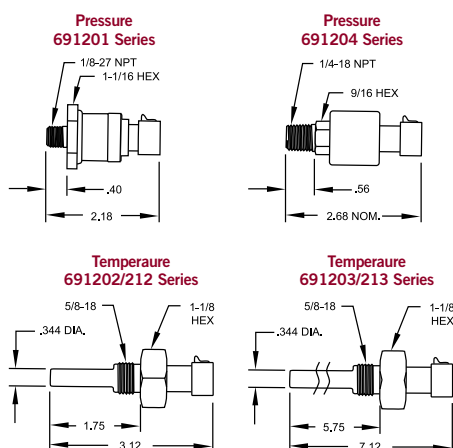

NOTE:  
OUTPUT CONNECTOR MATES WITH  
PACKARD METRI-PACK #12065287

## Altronic Barriers

The Altronic 690107 and 690108 series Barriers are designed to accept input from an Altronic C.D. ignition system and to output an intrinsically-safe signal to operate most Altronic ignition-powered digital instruments. The table below identifies the appropriate barrier for use with the appropriate Altronic ignition system. When used with the correct barrier, most Altronic digital instruments achieve full CSA certification for safe use in Class I, Division 1, Group D hazardous areas without the need for an explosion-proof enclosure. Please refer to the individual product data sheets and installation instructions for complete details on individual certifications.

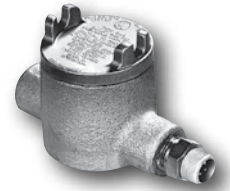

Barrier Model	Applicable Altronic Ignition Systems
690107	Altronic I, I-6, III, III-CPU, V, CPU-90/95, DISN
690108	Altronic II, II-CPU, CPU-2000

## Industrial and Explosion-Proof Enclosures

Enclosures for both the 4-1/2" round and rectangular JIC enclosure instrument products are available as accessory items. Both enclosure varieties are available for purchase at the time the instrument is ordered, and as an independent part number.

- (-W) Industrial Enclosure (690014-1) is a gasketed, anodized aluminum enclosure available for 4-1/2" round instruments only. The device retains its Class I, Division 2, Group D rating when mounted in this enclosure. It has a bottom conduit entry for wiring and can be wall or conduit mounted.
- (-X) Explosion-Proof Enclosure can be used to achieve a Class I, Division 1, Group D certification where necessary. It is available for both 4-1/2" round (690013-1) and rectangular JIC-cased devices (690012-1).



# Custom Control Panel Design and Manufacturing



**Altronic Controls**  
1410 North First Street  
Garland, Texas 75040  
Tel (972) 494-0522  
Fax (972) 272-4017  
sales@altroniccontrols.com



Altronic Controls Inc (ACI) engineers and builds custom, premium-quality control panels. Using Altronic CSA-certified instrumentation and controls, virtually any safety shutdown, engine control, or automation panel requirement can be met, including for applications in challenging environments or for hazardous duty operation where instruments described as “suitable for service” simply do not measure up.

Designing and constructing control panels for the oil and gas industry is a customer-intensive process. From the specification phase, through the panel installation and commissioning effort, ACI engineers and distributor sales/service personnel work closely with the customer to assure that the panel approach, design, and construction meet the operational, service, and environmental durability requirements unique to each location and application.

Each ACI panel follows the same sequence of development.

## Establishing the Specification

Determining which points are to be monitored and/or how the engine is to be controlled through the start, warmup, run, and shutdown cycles is clearly the most critical portion of the panel development process. Altronic field personnel, in conjunction with distributor sales and service groups, work closely with the customer to properly understand the application and the desired control strategy.

## Turning the Specification into a Reliable, Cost-Effective Design

Using Altronic instrumentation and control products—as well as complimentary products built by other manufacturers—ACI engineers must insure that the provided specifications and control requirements are met with a reliable, cost effective controls solution. This requires

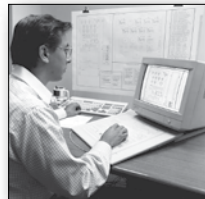

attention to detail and relies on more than 100 man-years of cumulative control panel design experience

at Altronic Controls. It may also include further consultation with the customer to suggest alternate design approaches or controls to better suit the application or budgetary requirements.

## Construction and Testing/Validation of the Control Panel

After the development and design stage, responsibility shifts to the Altronic Controls production and quality assurance

group. A control panel is much more than a box full of boxes. A reliable panel that will provide the customer with long-term, trouble-free service must be constructed in accordance with a strict set of assembly guidelines. This includes termination ferrules and wire tags on every wire, well-routed tubing, separated low and high voltage wiring, and high quality enclosures and finishes. It also means rigorously testing every electrical or process tubing point in the panel with either high pressure air or hydraulics, calibrating all transducers to the instrument, and checking every function in the panel.



## Installation and Commissioning

Drawing on its technical staff, as well as the expertise of Altronic Regional Managers and authorized Distributors, the Altronic Controls team is unparalleled in the industry in its ability to properly and economically install and start up a control panel. With trained Distributor installation and service personnel located all over the world, the control panel end user is assured of an effective, reasonably priced, and timely response to any technical issue that might arise throughout the service life of the product.

# Control Panels from Altronic Controls

Engine, compressor, and pump-monitoring and control panels are available in a range of sizes and shapes, with an equally broad array of capabilities. From simple monitoring and protection to more active engine or process control, Altronic Controls can deliver exactly the right mix of Altronic and non-Altronic hardware to meet the specific needs and budget of the user.

## DD-40NTV/DE-2200 Safety Shutdown Panels

For the user seeking simple but effective engine/package protection, Altronic Controls offers Altronic DD-40 and DD-40NTV-based shutdown panels. Designed for small and medium-sized applications, these panels often feature high-quality 45PHL Pressure Switch-Gauges and other Altronic temperature monitoring instrumentation. Alternatively, a user might turn to the Altronic DE-2200 “panel in a box” as a more full-featured annunciator option with direct transducer inputs for monitoring temperatures and pressures.



offer active, closed-loop control for a variety of functions, including compressor slide valve and recycle valve control.

## Altronic Exacta21 and PLC-Based Monitoring and Control Panels for Gas Compressors

Altronic Controls offers a full line of control panels constructed around the purpose-built Exacta21 gas engine and compressor controller (see pages 8 and 9), as well as commercially available PLCs (programmable logic controllers). These high-end control systems—most frequently used on larger field gas compression units, in gas processing service, or on mainline gas transmission compressors—offer comprehensive monitoring and control capabilities, and often incorporate advanced HMI (human machine interface) modules such as the MIDAS system outlined below.



## DE-1500/2500/3000 Monitoring and Control Panels

Users in need of cost-effective throughput and or other control functionality beyond the safety shutdown functions often turn to DE-based panels from Altronic Controls. In addition to directly accepting analog transducer inputs, the DE-1500, 2500 and 3000 products

## Altronic Air/Fuel Ratio Control Panels

Built into a stand-alone enclosure, or integrated into a larger safety-shutdown or control system, the Altronic EPC-series air/fuel ratio control systems can be packaged to meet virtually any application requirement. An ACI air/fuel ratio auxiliary panel is an ideal “bolt-on” solution where additional monitoring or control functionality is not required.



## MIDAS Control System Interface Module

MIDAS (Monitored Information Devices And Systems) combines the advanced display capabilities of a PLC-based system with the reliability and serviceability of a control panel built around independent, discrete devices. Using “pre-manufactured” system data screens and a standard display structure, the MIDAS acts as a data collection and presentation hub. The touch screen provides an advanced, user-configurable, graphical data presentation, delivering centralized access to critical information in parallel with the individual instrument and control displays and keypads within the panel.



*The HOERBIGER Group*

*HOERBIGER Compression Technology is a business unit of HOERBIGER Holding AG, Zug / Switzerland. HOERBIGER is active throughout the world as a leading player in the fields of compression technology, automation technology and drive technology. Its 6,400 employees achieve sales of around 1 billion Euro. The focal points of its business activities include key components and services for compressors, gas engines and turbomachines, hydraulic systems and piezo technology for vehicles and machine tools, as well as components and systems for shift and clutch operations in vehicle drive trains of all kinds. Through innovations in attractive technological niche markets, the HOERBIGER Group sets standards and delivers cutting-edge solutions for the benefit of its customers.*



**ALTRONIC INC**  
712 Trumbull Avenue  
Girard, Ohio 44420 USA  
P: 330-545-4045  
F: 330-545-9005

**ALTRONIC CONTROLS INC**  
1410 North First Street  
Garland, Texas 75040  
P: 972-494-0522  
F: 972-272-4017

**ALTRONIC EUROPE BV**  
De Tienden 50A  
5674 TB Nuenen  
The Netherlands  
P: 011-31-40-2906270  
F: 011-31-40-2838990

Form ADI-C 9-09