

DINnectors Accessories

End Brackets

The DN-EB15 end brackets mount on 15 mm DIN rail, and DN-(Q)EB35(-A) end brackets are designed to mount on 35 mm DIN rail. End brackets are used to prevent components from sliding along the rail.

| Part Number | Description | Pcs/Pkg | Price/Pkg |
|--------------|---|---------|-----------|
| DN-EB15 | Terminal block end stop 7mm width screw clamping. Gray | 100 | <---> |
| DN-EB15MN | | 20 | <---> |
| DN-EB35 | Terminal block end stop 9mm width screw clamping. Gray | 50 | <---> |
| DN-EB35MN | | 20 | <---> |
| DN-EB35-A | Terminal block end stop 6mm width screw clamping. Black | 50 | <---> |
| DN-EB35-A-10 | | 10 | <---> |
| DN-QEB35 | Terminal block end stop 6mm width screwless clamping. Black | 50 | <---> |
| DN-QEB35-10 | | 10 | <---> |

DN-EB15

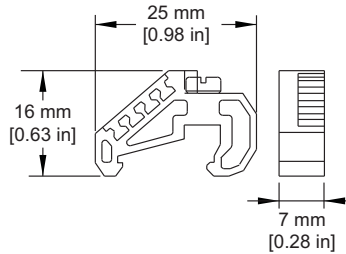

DN-EB35

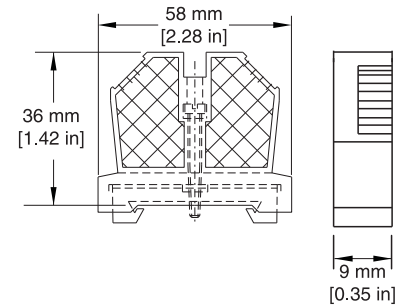

DN-EB35-A

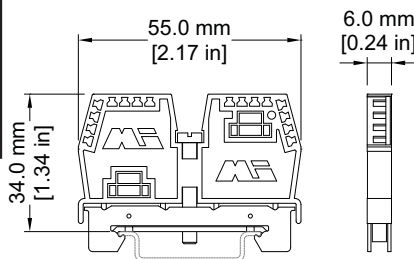

DN-QEB35

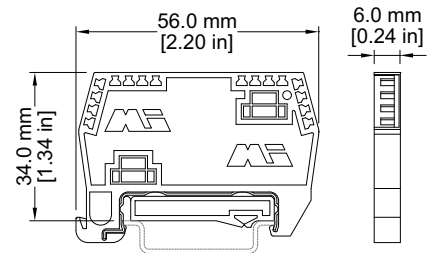

End Covers & Spacers

Certain end covers can be used with multiple terminal block parts to cover and insulate the open side, or to put more space between adjacent blocks.

| Part Number | Length | Height | Thickness |
|-------------|-----------------|-----------------|------------------|
| DN-EC1210 | 44 mm [1.73 in] | 35 mm [1.38 in] | 1.5 mm [0.06 in] |
| DN-EC1210MN | | | |
| DN-EC86 | 50 mm [1.97 in] | 43 mm [1.69 in] | 1.5 mm [0.06 in] |
| DN-EC86MN | | | |

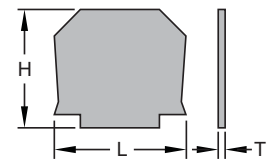

| Part Number | Purpose | For TBs: | Pcs/Pkg | Price/Pkg |
|--------------|------------------------------|-----------------------|---------|-----------|
| DN-EC1210 | covers open side of TB | DN-T10-A | 100 | <---> |
| DN-EC1210MN | covers open side of TB | DN-T12-A | 25 | <---> |
| DN-EC86 | covers open side of TB | DN-T8 | 100 | <---> |
| DN-EC86MN | covers open side of TB | DN-T6 | 25 | <---> |
| DN-EMXM1EC1 | covers open side of TB | DN-EMXM1 DN-QEMXM1 | 25 | <---> |
| DN-EMXM1EC2 | covers closed side of TB | | | <---> |
| DN-EMXM1SPA1 | spacer for either side of TB | | | <---> |
| DN-EMXDVEC1 | covers open side of TB | DN-EMXDV DN-QEMXDV | 25 | <---> |
| DN-EMXDVEC2 | covers closed side of TB | | | <---> |
| DN-EMXDVSPA1 | spacer for either side of TB | | | <---> |
| DN-FESEP | covers open side of TB | DN-FEx DN-DISx | 50 | <---> |
| DN-FESEP-10 | covers open side of TB | | 10 | <---> |
| DN-FESPA | wider cover open side of TB | | 50 | <---> |
| DN-FESPA-10 | wider cover open side of TB | | 10 | <---> |

Note: End covers for DN-M10-A, DN-T4 and DN-KBD12 are found in their respective Accessories table.

DN-EMXM1EC1

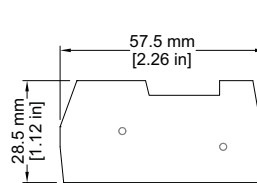

DN-EMXM1EC2

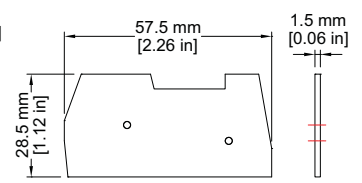

DN-EMXM1SPA1

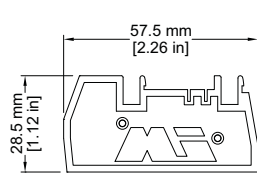

DN-EMXDVSPA1

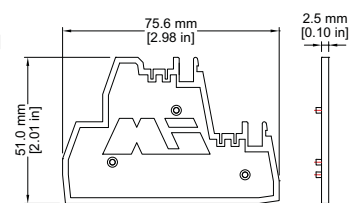

DN-EMDVEC1

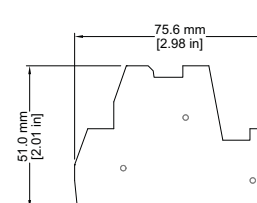

DN-EMDVEC2

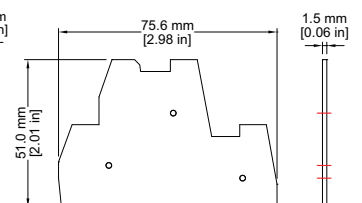

DN-FESEP

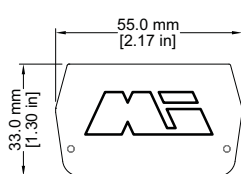

DN-FESEPA

