

AB *Allen-Bradley*

Technical Data

Bulletin 160 "Series C" Smart Speed Controllers



Allen-Bradley
RELIANCE ELECTRIC DODGE
ROCKWELL SOFTWARE
**Rockwell
Automation**

A Step Above the Rest...

Bulletin 160 Smart Speed Controller (SSC™) with Sensorless Vector Performance

The **Bulletin 160** Smart Speed Controller is available in models rated between 0.37 to 4 kW (0.5 to 5 horsepower) with voltage ratings 200-240V and 380-460V three-phase input and 0.37 to 1.5 kW (0.5 to 2 horsepower) 200-240V single phase input.

When the Bulletin 160 SSC was first introduced in the market, its innovative design helped set the standard for future microdrives. With the Series C design, expanded power ratings (through 5 HP, 4 kW), increased functionality and an enhanced hardware design place the Bulletin 160 SSC a "Step Above the Rest" for small drive applications!



Bulletin 160 “Series C” Smart Speed Controller with Sensorless Vector Performance

Technical Data

TABLE OF CONTENTS

Standard Drives Program

<u>Description</u>	<u>Page</u>
Catalog Number Description	5
Product Selection	5
Operator Interface & Communication Devices	6
Accessories	7
Accessories and Repair Parts – Field Installed	8
Bulletin 160 Block Diagram	10
Branch Circuit Block Diagram	10
Specifications	11
Approximate Dimensions	13
Communication Module Specifications	17
Display Parameter Descriptions	17
Program Parameter Descriptions	18

Standard Drives Program – 160Z

Catalog Number Description	19
Product Selection	19
Operator Interface ^① & Communication Devices	20
Specifications	21
Approximate Dimensions	23

Standard Packaged Drive Program

Ordering Instructions	24
Custom Configured Drives Program	24
Catalog Number Description	24
Product Selection	24
Factory Installed Enclosure Options	25
Option Rules	25
Approximate Dimensions for 160 NEMA Type 4/12 & 4X Stainless Steel Enclosures	26

The 160 SSC (Smart Speed Controller) is a compact variable speed drive for use on three-phase induction AC motors. It is microprocessor controlled and fully programmable for a variety of applications.

Standard Features Include:

- Ratings of 0.37-4.0 kW (0.5-5 HP)
- Very Compact Design
- Feed Through Wiring
- IGBT Technology
- PWM Control
- Quiet Operation
- Programmable

Standard Drive Configurations:

- IP20 (Open Style)
- Chassis Mount
- 160Z (IP 65/NEMA 4X)

Standard Packaged Drives Available:

- IP66 (NEMA 4/12)
- IP66 (NEMA 4X)

Approvals:

- UL (UL 508C)
- C/UL (CSA 22.2)
- CE^① EMC Directive (EMC: EN61800-3, EN50081-1, EN50082-2)
Low Voltage Directive (LVD: EN50178, EN6024-1)
- C-Tick AS/NZS2064

^① External components and proper guidelines must be followed. Refer to the 160 User Manual for details.



Your order must include

- Catalog number of the drive
- If required, catalog number of any accessories and/or factory installed options.

Standard Drives Program

Catalog Number Description

160

Bulletin Number

– AA02

Drive Rating
(must be specified)

N

Enclosure Rating
(must be specified)

SF1

Control Model
(must be specified)

P1

Programmer
(optional)

Product Selection

	Input Voltage Rating	Drive Ratings			IP 20 (Open Style)	
		kW	HP	Output Current Rating	Analog Signal Follower Model Catalog Number ^{①③}	Preset Speed Model Catalog Number ^{①③}
	200-240V 50/60 Hz Single-Phase	0.37	0.5	2.3A	160S - AA02NSF1	160S - AA02NPS1
		0.55	0.75	3.0A	160S - AA03NSF1	160S - AA03NPS1
		0.75	1	4.5A	160S - AA04NSF1	160S - AA04NPS1
		1.5	2	8.0A	160S - AA08NSF1	160S - AA08NPS1
	200-240V 50/60 Hz Three-Phase	0.37	0.5	2.3A	160 - AA02NSF1	160 - AA02NPS1
		0.55	0.75	3.0A	160 - AA03NSF1	160 - AA03NPS1
		0.75	1	4.5A	160 - AA04NSF1	160 - AA04NPS1
		1.5	2	8.0A	160 - AA08NSF1	160 - AA08NPS1
		2.2	3	12.0A	160 - AA12NSF1	160 - AA12NPS1
		4.0	5	18.0A	160 - AA18NSF1	160 - AA18NPS1
	380-460V 50/60 Hz Three-Phase	0.37	0.5	1.2A	160 - BA01NSF1	160 - BA01NPS1
		0.55	0.75	1.7A	160 - BA02NSF1	160 - BA02NPS1
0.75		1	2.3A	160 - BA03NSF1	160 - BA03NPS1	
1.5		2	4.0A	160 - BA04NSF1	160 - BA04NPS1	
2.2		3	6.0A	160 - BA06NSF1	160 - BA06NPS1	
4.0		5	10.5A	160 - BA10NSF1	160 - BA10NPS1	

	Input Voltage Rating	Drive Ratings			IP 20 (Chassis Mount) ^②	
		kW	HP	Output Current Rating	Analog Signal Follower Model Catalog Number ^{①③}	Preset Speed Model Catalog Number ^{①③}
	200-240V 50/60 Hz Single-Phase	0.37	0.5	2.3A	160S - AA02PSF1	160S - AA02PPS1
		0.55	0.75	3.0A	160S - AA03PSF1	160S - AA03PPS1
		0.75	1	4.5A	160S - AA04PSF1	160S - AA04PPS1
		1.5	2	8.0A	160S - AA08PSF1	160S - AA08PPS1
	200-240V 50/60 Hz Three-Phase	0.37	0.5	2.3A	160 - AA02PSF1	160 - AA02PPS1
		0.55	0.75	3.0A	160 - AA03PSF1	160 - AA03PPS1
		0.75	1	4.5A	160 - AA04PSF1	160 - AA04PPS1
		1.5	2	8.0A	160 - AA08PSF1	160 - AA08PPS1
		2.2	3	12.0A	160 - AA12PSF1	160 - AA12PPS1
		4.0	5	18.0A	160 - AA18PSF1	160 - AA18PPS1
	380-460V 50/60 Hz Three-Phase	0.37	0.5	1.2A	160 - BA01PSF1	160 - BA01PPS1
		0.55	0.75	1.7A	160 - BA02PSF1	160 - BA02PPS1
0.75		1	2.3A	160 - BA03PSF1	160 - BA03PPS1	
1.5		2	4.0A	160 - BA04PSF1	160 - BA04PPS1	
2.2		3	6.0A	160 - BA06PSF1	160 - BA06PPS1	
4.0		5	10.5A	160 - BA10PSF1	160 - BA10PPS1	







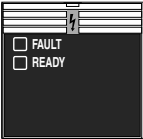

① The Bulletin 160 comes standard with a Ready/Fault indication panel. To order a drive with a Program Keypad Module installed, add suffix "P1" to the catalog number. For example: Catalog Number 160-AA02NSF1 becomes 160-AA02NSF1P1

② Meets IP54/65/66 (NEMA 12/4/4X) when installed in suitable enclosure.

③ For pricing information refer to the Bulletin 160 Price Sheet.

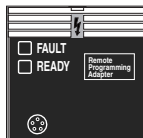
Standard Drives Program

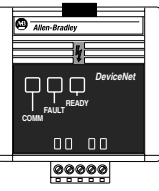





Operator Interface & Communication Devices

Accessory	Description	Catalog Number ^①
	Ready/Fault Indicating Panel - Indicates if the drive is READY for operation or if a FAULT condition has occurred. This module is provided as “standard equipment” when no other factory installed options are ordered.	160-B1
	Program Keypad Module - Provides the ability to program and/or monitor all drive parameters as well as provide local keypad control (start, stop and reverse functions). See page 5, Footnote 1, for information on how to order this option factory installed.	160-P1
	Remote Keypad Module - Provides the ability to mount the operator interface remote from the drive. A Remote Programming Adapter (160-RPA) and cable must be ordered separately.	160-P2
	CopyCat Keypad Module - Provides the ability to program or monitor individual drive parameters or upload and download all drive parameters. A Remote Programming Adapter (160-RPA) and cable must be ordered separately.	160-P3
	Remote Programming Adapter - Provides a simple interface connection for the Remote and CopyCat Keypad Modules.	160-RPA
	Cables - Connects the Remote Programming Adapter to either the Remote or CopyCat Keypad Module. Several different cable lengths and types are available.	See page 8
	Communications Module - Allows control and monitoring of parameters via the networks listed below. These modules add 21.4 mm (0.85 in.) to the overall depth of the drive. See page 16 for dimensional information. Communication modules are as follows: <ul style="list-style-type: none"> • DeviceNet • RS232 Serial Communications • Profibus • Interbus 	160-DN2 160-RS1 160-PD1 160-IB1
	DriveExplorer™ Software - Windows™ based software package that provides an intuitive means for monitoring or configuring Allen-Bradley drives and communications adapters.	9306-4KS0EFF

① For pricing information refer to the Bulletin 160 Price Sheet.

Standard Drives Program

Accessories

Accessory	Description	Ordering Information	Dimension Information
	<p>Dynamic Brake Module - Provides external dynamic braking capability for applications with a duty cycle rating not exceeding 5%. Parameter 52 (DB Enable) must be set to 5% to achieve this performance level. For applications greater than 5%, a resistor package must be properly sized to avoid overheating.</p>	See Page 8	See Page 14
	<p>Capacitor Module - Provides extended ride through capability and increases inherent braking performance. This module connects to the load side power terminals marked DC- and DC+.</p>	See Page 9	See Page 14
	<p>Line Filter Module - Reduces conductive emissions to meet EMC compliant installations. The line filters are designed so that the drive can be mounted on top (piggyback) of the line filter module to help reduce overall enclosure size.</p>	See Page 9	See Page 15
	<p>Line Reactor - Provides input power conditioning when installed on the line side of the drive, or reflected wave protection when installed on the load side of the drive. When used for reflected wave protection, the reactor should be mounted close to the motor. Consult the 160 Drive User Manual for recommendations on when to use this device.</p>	See Page 8	See Page 15
	<p>RWR Module - Reduces potentially destructive reflected wave spikes that can occur in applications with long cable distances between the drive and motor. This device is designed for installation close to the output terminals of the drive. Consult the 160 Drive User Manual for recommendations on when to use this device.</p>	See Page 8	See Publication 1204-5.1
	<p>24V DC Interface Module - Allows use of 24V DC “sink logic” control. Two versions are available, one for preset speed models and one for analog signal follower models. The 24V DC interface attaches directly to the drives' control terminal block.</p>	See Page 8	No added panel space is necessary with this device.

Standard Drives Program



Accessories and Repair Parts – Field Installed

Accessories

Catalog Number	Description ^⑥
160-DM-SF1 ^①	24V DC Interface (Analog Model)
160-DM-PS1 ^①	24V DC Interface (Preset Model)
160-C10R	1.0 m (3.3 ft.) Cable w/ right angle connector
160-C10	1.0 m (3.3 ft.) Cable
160-C30	3.0 m (9.8 ft.) Cable
160-C50	5.0 m (16.4 ft.) Cable
1321-M001	Ferrite core (unwound)
1321-M009	Ferrite core (wound)

Repair Parts

Catalog Number	Description ^⑥
160-FRK1	Fan Replacement Kit, 0.75-2.2 kW (1-3 HP) for Series A or B drives
160-FRK2	Fan Replacement Kit, 0.75-2.2 kW (1-3 HP) for Series C drives
160-FRK3	Fan Replacement Kit, 4 kW (5 HP) for Series C drives

Drive Ratings			Dynamic Brake Module	Line Reactors - Open Style	RWR Module
					
Input Voltage Rating	kW	HP	Catalog Number ^⑥	Catalog Number ^{②⑥}	Catalog Number ^{④⑥}
200-240V, 50/60 Hz, Single-Phase	0.37	0.5	–	–	–
	0.55	0.75	–	–	–
	0.75	1	160-BMA1	–	–
	1.5	2	160-BMA2	–	–
200-240V, 50/60 Hz, Three-Phase	0.37	0.5	–	1321-3R4-B	–
	0.55	0.75	–	1321-3R4-A	–
	0.75	1	160-BMA1	1321-3R4-A	–
	1.5	2	160-BMA2	1321-3R8-A	–
	2.2	3	160-BMA2	1321-3R12-A	–
	4.0	5	160-BMA2 ^③	1321-3R18-A	–
380-460V, 50/60 Hz, Three-Phase	0.37	0.5	–	1321-3R2-B	1204-RWR2-09-B
	0.55	0.75	–	1321-3R2-A	1204-RWR2-09-B
	0.75	1	160-BMB1	1321-3R2-A	1204-RWR2-09-B
	1.5	2	160-BMB2	1321-3R4-B	1204-RWR2-09-B
	2.2	3	160-BMB2	1321-3R8-B	1204-RWR2-09-B
	4.0	5	160-BMB2 ^③	1321-3R18-B	1204-RWR2-09-B ^⑤

① Series B 24V Interface Modules are required for use with Series C Drives.

② Catalog numbers listed are for 3% impedance open style units. NEMA Type 1 and 5% impedance reactor types are also available, refer to publication 1321-2.0.

③ TWO UNITS MUST BE USED, wired in parallel.



④ Refer to Publication 1204-5.1 for dimensional information on RWR Devices.

⑤ The 1204-RWR2-09-B may be used at a 10.5 Amp current rating providing the cable length from drive to motor is less than 122 meters (400 feet).

⑥ For pricing information refer to the Bulletin 160 Price Sheet.

Standard Drives Program

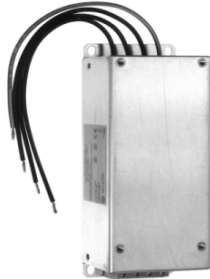
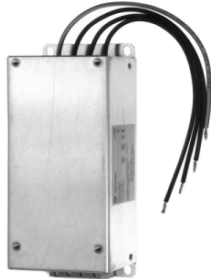
Accessories and Repair Parts – Field Installed

Drive Ratings			“LF” Line Filter Module	“RF” Line Filter Module	Capacitor Module
					
Input Voltage Rating	kW	HP	Catalog Number ①③④	Catalog Number ②③④⑥	Catalog Number ③
200-240V, 50/60 Hz, Single-Phase	0.37	0.5	160S-LFA1	160S-RFA-9-A	160-CMA1
	0.55	0.75	160S-LFA1	160S-RFA-9-A	160-CMA1
	0.75	1	160S-LFA1	160S-RFA-9-A	160-CMA1
	1.5	2	160S-LFA1⑤	160S-RFA-16-B	160-CMA1
200-240V, 50/60 Hz, Three-Phase	0.37	0.5	160-LFA2	160-RFB-5-A	160-CMA1
	0.55	0.75	160-LFA2	160-RFB-5-A	160-CMA1
	0.75	1	160-LFA2	160-RFB-5-A	160-CMA1
	1.5	2	160-LFA2	160-RFB-14-A	160-CMA1
	2.2	3	160-LFA2	160-RFB-14-A	160-CMA1
	4.0	5	–	160-RFA-22-B	160-CMA1
380-460V, 50/60 Hz, Three-Phase	0.37	0.5	160-LFB1	160-RFB-5-A	160-CMB1
	0.55	0.75	160-LFB1	160-RFB-5-A	160-CMB1
	0.75	1	160-LFB1	160-RFB-5-A	160-CMB1
	1.5	2	160-LFB1	160-RFB-5-A	160-CMB1
	2.2	3	160-LFB1	160-RFB-14-A	160-CMB1
	4.0	5	–	160-RFB-14-B	160-CMB1

- ① The 160LF type filters have been tested with a maximum motor cable length of 75 meters (246 feet) for 230V units and 40 meters (131 feet) for 460V units. Refer to the 160 User Manual (publication 0160-5.15) for detailed installation considerations.
- ② The 160RF type filters have been tested with a maximum motor cable length of 25 meters (82 feet) for both 230V and 460V units. Refer to the 160 User Manual for more detailed installation considerations.
- ③ For pricing information refer to the Bulletin 160 Price Sheet.
- ④ Bulletin 160 Series C drives (with proper filter) meet:
 - Overall EMC requirements of EN61800-3 for Second (Industrial) Environments
 - High frequency conducted and radiated emissions of EN61800-3 for (First) Residential Environments
 - High frequency conducted and radiated emissions of EN55011 for (Second) Industrial Environments
- ⑤ Must mount separately when used with Series C drives.
- ⑥ Must be used with Series C drives.

Standard Drives Program

Bulletin 160 Block Diagram

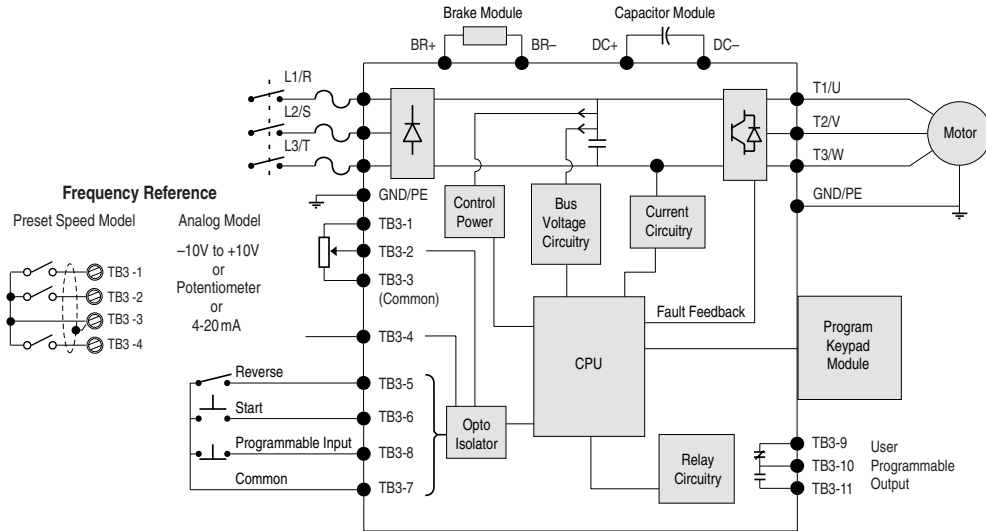

Branch Circuit Block Diagram

Short circuit and overload protection are requirements of any motor branch circuit. Input power conditioning, CE conformance, motor cable length and motor cable type (reflected wave and capacitive current coupling considerations) are important considerations of drive applications.

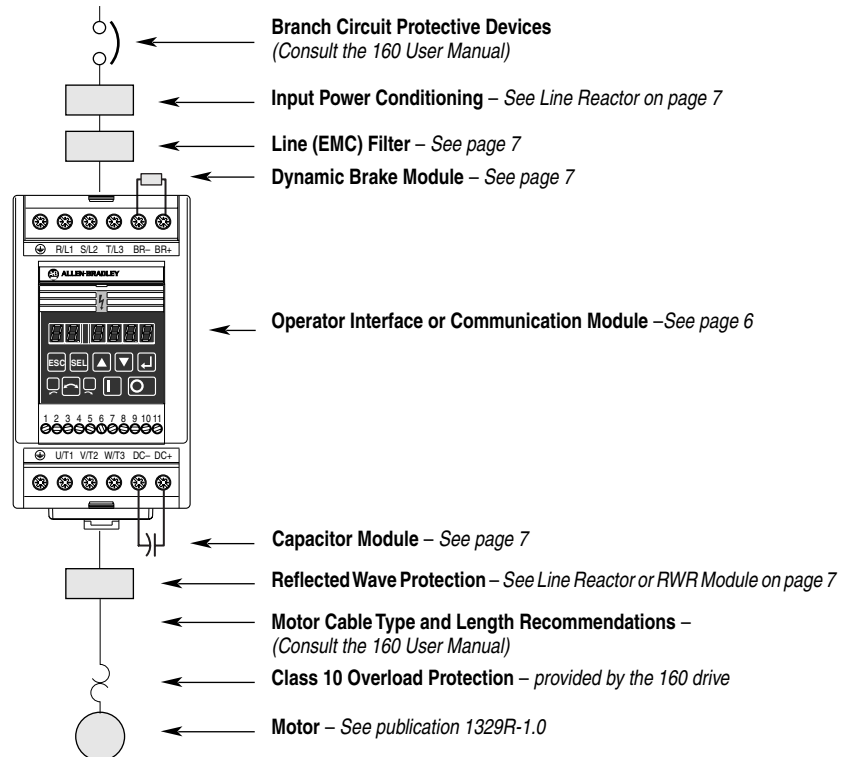

Standard Drives Program

Specifications

Drive Ratings										
IP20 Catalog Number		Output Ratings			Input Ratings		Dynamic Braking Torque		Power Dissipation	
Single-Phase Input, 50/60 Hz	Three-Phase Input, 50/60 Hz	kW	HP	Output Current	Operating Voltage Range	kVA	Without External Resistor	With External Resistor	IP20 (Open Style)	IP 20 (Chassis Mount)
200 - 240V										
160S-AA02	160-AA02	0.37	0.5	2.3A	180-265V	1.4	100%	–	20W	4W
160S-AA03	160-AA03	0.55	0.75	3.0A	180-265V	1.8	100%	–	25W	5W
160S-AA04	160-AA04	0.75	1	4.5A	180-265V	2.7	100%	200%	35W	10W
160S-AA08	160-AA08	1.5	2	8.0A	180-265V	4.0	50%	150%	74W	15W
–	160-AA12	2.2	3	12.0A	180-265V	7.1	50%	115%	107W	20W
–	160-AA18	4.0	5	18.0A	180-265V	10.6	20%	100%	137W	–
380 - 460V										
–	160-BA01	0.37	0.5	1.2A	340-506V	1.4	100%	–	25W	4W
–	160-BA02	0.55	0.75	1.7A	340-506V	2.0	100%	–	30W	5W
–	160-BA03	0.75	1	2.3A	340-506V	2.7	100%	200%	37W	8W
–	160-BA04	1.5	2	4.0A	340-506V	4.7	50%	150%	50W	15W
–	160-BA06	2.2	3	6.0A	340-506V	7.1	50%	115%	77W	20W
–	160-BA10	4.0	5	10.5A	340-506V	12.3	20%	100%	120W	–

Input/Output Ratings (All Drive Ratings)	
Output Voltage	Adjustable from 0V to input voltage
Output Frequency	0 to 240 Hz - Programmable
Efficiency	97.5% (Typical)
Transient Protection	Standard 6kV (Series C drives)

Environmental Specifications (All Drive Ratings)	
Enclosure	IP 20/IP66 (NEMA Type 12/4/4X)
Ambient Temperature IP 20 IP 66 (NEMA Type 12/4/4X)	0 to 50 degrees C (32 to 122 degrees F) 0 to 40 degrees C (32 to 104 degrees F)
Storage Temperature	–40 to 85 degrees C (–40 to 185 degrees F)
Relative Humidity	0 to 95% (non condensing)
Vibration	1.0 G Operational - 2.5 G Non-operational
Shock	15 G Operational - 30 G Non-operational
Altitude	1,000 meters (3,300 feet) without derating

Control Inputs	
Control Input Type	For dry contact closure input - drive has an internal 12V power supply that provides 10mA (typical) current. Also accepts open collector/solid-state input with maximum leakage current of 50µA. Optional 24V DC interface allows use of 24V DC "sink logic" inputs.
Start, Stop, Forward/Reverse	Configurable inputs for 2 or 3 wire control

Control Inputs (Analog Signal Follower Model Only)	
Analog Input (4 to 20mA)	Input impedance 250 ohms
Analog Input (-10 to +10V DC)	Input impedance 100k ohms
External Speed Potentiometer	1k to 10k ohms, 2 Watt minimum
PI Control	Parameter 46, setting 9 provides PI Control function
SW1, SW2	Parameter 46, setting 8 provides 4 preset speeds and 2 accel/decel times

Standard Drives Program

Specifications, Continued

Control Inputs (Preset Speed Model Only)	
SW1, SW2, SW3	Configurable inputs for control of 8 preset speeds and 2 accel/decel times
Control Output	
Programmable Output (form C relay contact)	Resistive Rating: 0.4A at 125V AC, 0.2A at 230V AC, 2A at 30V DC Inductive Rating: 0.2A at 125V AC, 0.1A at 230V AC, 1A at 30V DC Programmable for eleven different functions
Control Features	
PWM Algorithm	Sine weighted PWM with harmonic compensation
Switching Device (3-Phase Output)	IGBT (Insulated Gate Bipolar Transistor)
V/Hz Ratio	Programmable
Carrier Frequency	Adjustable from 2 kHz to 8 kHz in 100 Hz increments (factory default is 4 kHz)
DC Boost	Adjustable - Select from a family of boost curves
Current Limiting	Trip free operation, coordinated for drive and motor protection. Programmable from 1% to 180% of drive Output Current.
Motor Protection	I ² t overload protection - 150% for 60 seconds, 200% for 30 seconds (Provides Class 10 overload protection)
Overload Pattern #0	Flat response over speed range (no speed compensation)
Overload Pattern #1	Speed compensation below 25% of base speed
Overload Pattern #2	Speed compensation below 100% of base speed
Acceleration/Deceleration Time(s)	0.1 to 600 seconds
S-Curve Accel/Decel Time(s)	0 to 100% of accel/decel time - not to exceed 60 seconds
Stopping Modes	4 modes (programmable)
Ramp to Stop	0.1 to 600 seconds
Coast	Stops all PWM output
DC Injection Brake	Applies DC voltage to the motor for 0 to 25 seconds
DC Injection Braking w/ Auto Stop	Applies DC voltage to the motor for 0 to 25 seconds with Auto Shutoff
Protective Features	
Overcurrent	200% hardware limit, 300% instantaneous fault
Excessive Temperature	Embedded temperature sensor trips if heatsink temperature exceeds 95 degrees C (203 degrees F)
Over Voltage Drive Rated Input = 200-240V AC Drive Rated Input = 380-460V AC	DC Bus voltage is monitored for safe operation Overvoltage trip occurs at 400V DC bus voltage (equivalent to 290V AC incoming line voltage). Overvoltage trip occurs at 800V DC bus voltage (equivalent to 575V AC incoming line voltage).
Under Voltage Drive Rated Input = 200-240V AC Drive Rated Input = 380-460V AC	DC Bus voltage is monitored for safe operation Undervoltage trip occurs at 210V DC bus voltage (equivalent to 150V AC incoming line voltage). Undervoltage trip occurs at 390V DC bus voltage (equivalent to 275V AC incoming line voltage).
Control Ride Through	Minimum ride through is 0.5 seconds - typical value 2 seconds
Ground Fault	Protection in both Start and Run Mode
Faultless Ride Through	100 milliseconds
Output Short Circuit	Any output phase to phase short
Programming	
Programmer / Display Type	Program Keypad Module - 6 character LED display Remote Keypad Module - 4 character LED display CopyCat Keypad Module - 2 line, 16 character LCD display
Local Controls	SPEED, RUN, STOP, and DIRECTION controls

Standard Drives Program

Analog Signal Follower and Preset Speed Models - Approximate Dimensions

Dimensions are shown in millimeters (inches). Dimensions are not to be used for manufacturing purposes.

0.37 kW-2.2 kW (0.5-3 HP), Three-Phase, 200-240V AC & 380-460V AC

0.37 kW-0.75 kW (0.5-1 HP), Single-Phase, 200-240V AC

Approximate Weight is 0.94 kg (2.07 lbs.)

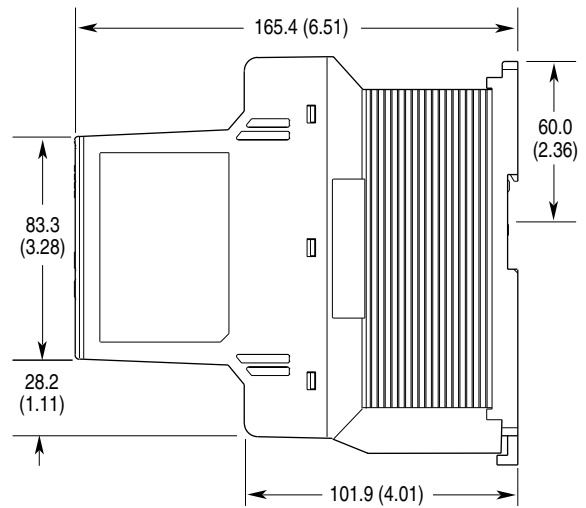
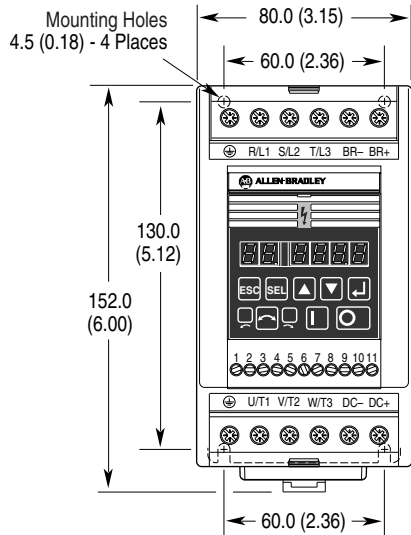

4.0 kW (5 HP), Three-Phase, 200-240V AC & 380-460V AC

1.5 kW (2 HP), Single-Phase, 200-240V AC

Approximate Weight is 2.37 kg (5.23 lbs.)

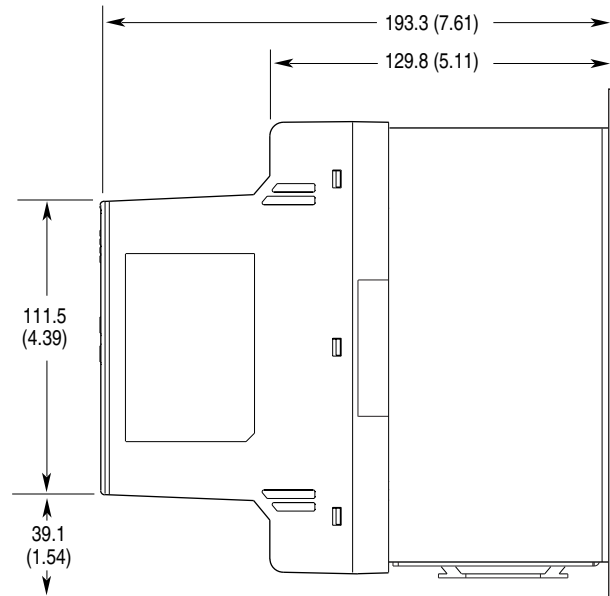
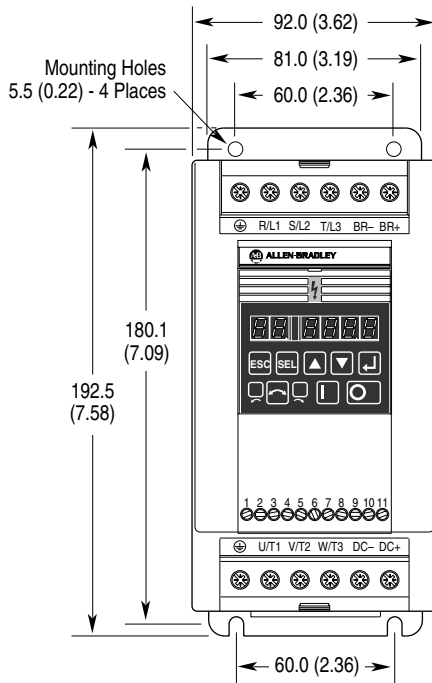

* **NOTE:** 12.7 mm (0.50 in.) is required around the top, bottom and front of all drives. No clearance is required between drives with the exception of the 2.2 kW (3 HP) rating which requires 8.4 mm (0.33 in.).

Standard Drives Program

Approximate Dimensions, Continued

Dimensions are shown in millimeters (inches). Dimensions are not to be used for manufacturing purposes.

Chassis Mount, All Ratings

Approximate Weight is 7.26 kg (16 lbs.) through 1.5 kW (2 HP) and 7.71 kg (17 lbs.) for 2.2 kW (3 HP)

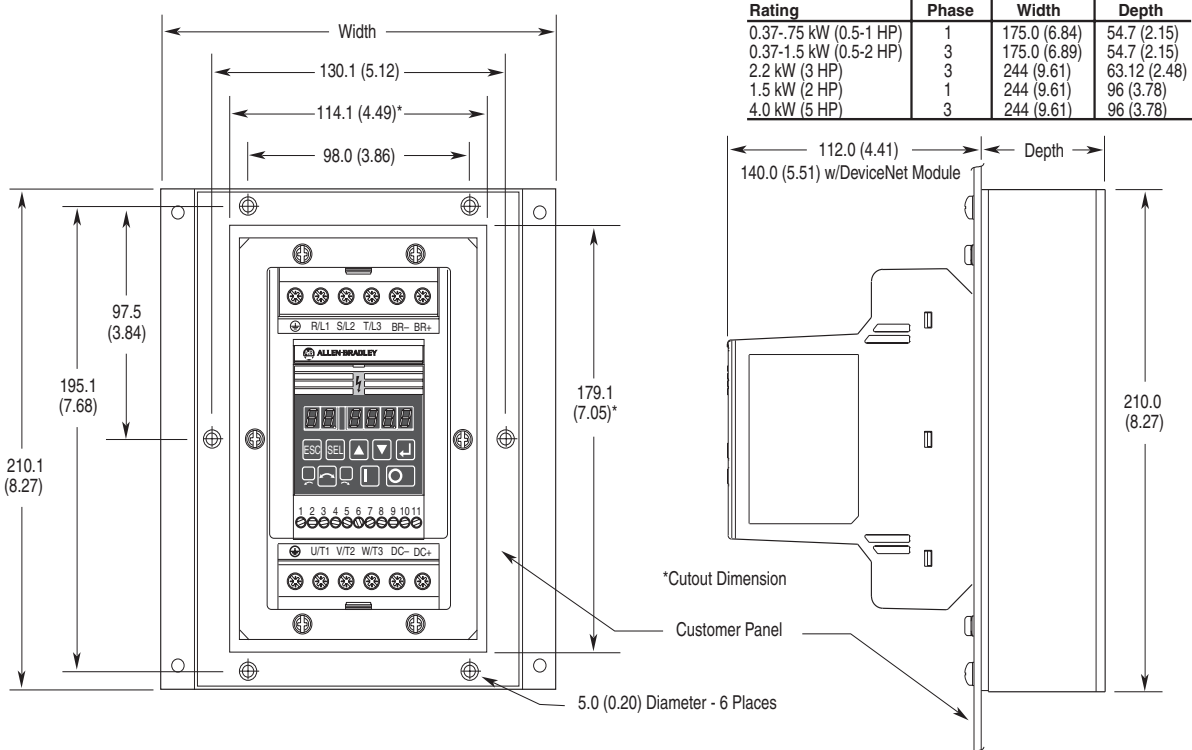

Dynamic Brake Module

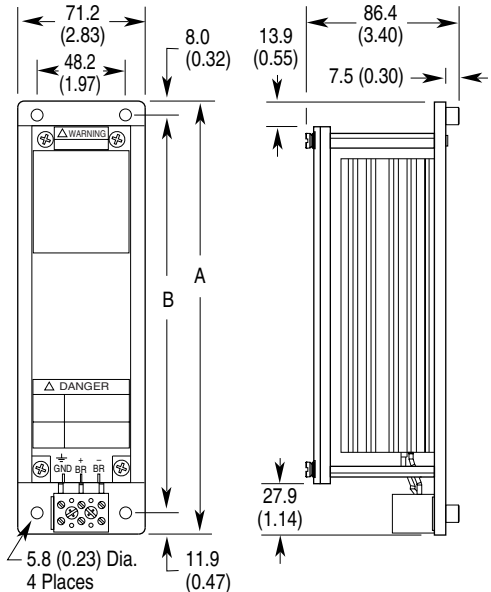

Catalog Number	A	B
160-BMA1, -BMB1	245.0 (9.64)	225.0 (8.86)
160-BMA2, -BMB2	334.0 (13.15)	314.0 (12.36)

Capacitor Module

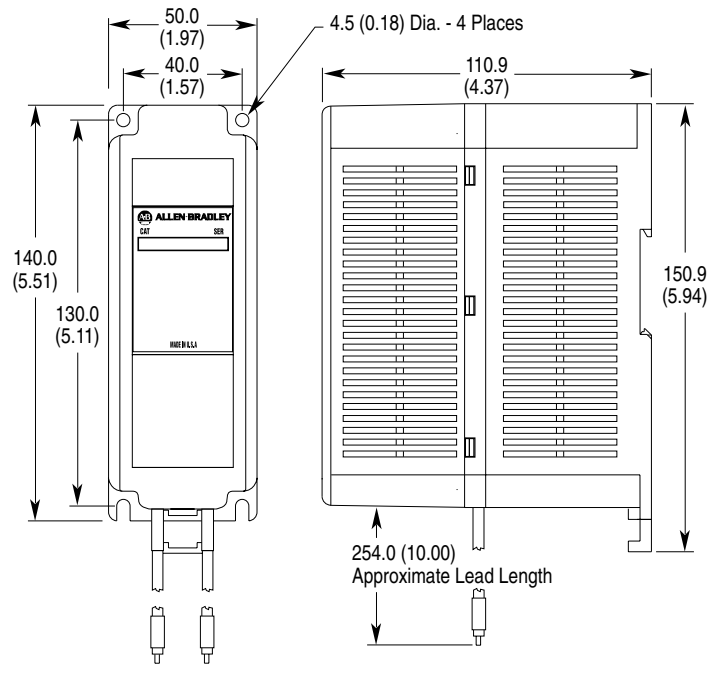

Standard Drives Program

Approximate Dimensions, Continued

Dimensions are shown in millimeters (inches). Dimensions are not to be used for manufacturing purposes.

Line Reactor

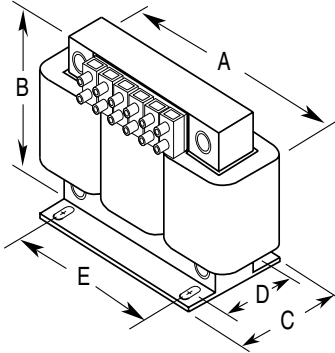

Catalog Number	A	B	C	D	E
1321-3R2-A	112 (4.40)	104 (4.10)	74 (2.90)	50 (1.98)	37 (1.44)
1321-3R2-B	112 (4.40)	104 (4.10)	74 (2.90)	50 (1.98)	37 (1.44)
1321-3R4-A	112 (4.40)	104 (4.10)	76 (3.00)	50 (1.98)	37 (1.44)
1321-3R4-B	112 (4.40)	104 (4.10)	76 (3.00)	50 (1.98)	37 (1.44)
1321-3R8-A	152 (6.00)	127 (5.00)	76 (3.00)	53 (2.10)	51 (2.00)
1321-3R8-B	152 (6.00)	127 (5.00)	76 (3.00)	53 (2.10)	51 (2.00)
1321-3R12-A	152 (6.00)	127 (5.00)	76 (3.00)	53 (2.10)	51 (2.00)
1321-3R18-A	152 (6.00)	133 (5.25)	79 (3.10)	51 (2.00)	51 (2.00)
1321-3R18-B	152 (6.00)	133 (5.25)	86 (3.40)	63 (2.48)	51 (2.00)

Line Filter Module

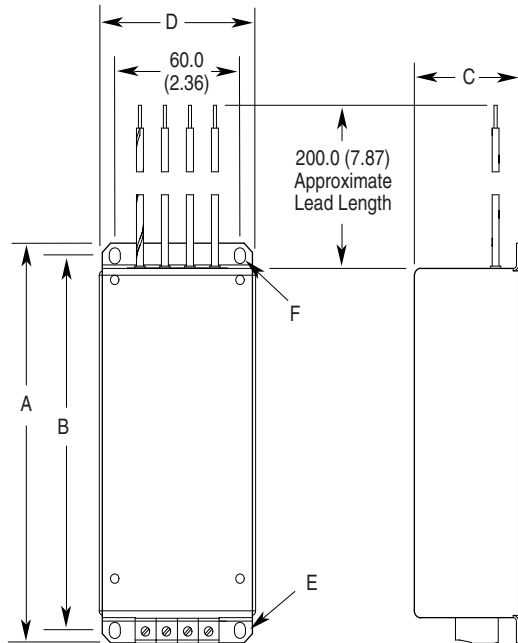

Catalog Number	A	B	C	D	E	F
160S-RFA-9-A	182 (7.17)	163 (6.42)	37.5 (1.47)	75 (2.95)	M4.5 x 6.5 (0.18 x 0.26)	6.6 x 4.5 (0.26 x 0.18) 2 Places
160-RFB-5-A	182 (7.17)	163 (6.42)	37.5 (1.47)	75 (2.95)	M4.5 x 6.5 (0.18 x 0.26)	6.6 x 4.5 (0.26 x 0.18) 2 Places
160-RFB-14-A	182 (7.17)	163 (6.42)	47.5 (1.87)	75 (2.95)	M4.5 x 6.5 (0.18 x 0.26)	6.6 x 4.5 (0.26 x 0.18) 2 Places
160-RFB-14-B	227 (8.94)	212 (8.35)	55.5 (2.18)	87 (3.43)	M4.5 (0.18)	6.6 x 4.5 (0.26 x 0.18) 2 Places
160-RFA-22-B						
160-RFA-16-B						
160S-LF (All)	174 (6.85)	163 (6.42)	50.0 (1.97)	75 (2.95)	6.9 x 5.3 (0.27 x 0.21)	7.0 x 5.3 (0.28 x 0.21)
160-LF (All)						

Three-Phase filter shown (single-phase filter is the same size)

Standard Drives Program

Approximate Dimensions, Continued

Dimensions are shown in millimeters (inches). Dimensions are not to be used for manufacturing purposes.

DeviceNet and RS-232 Module

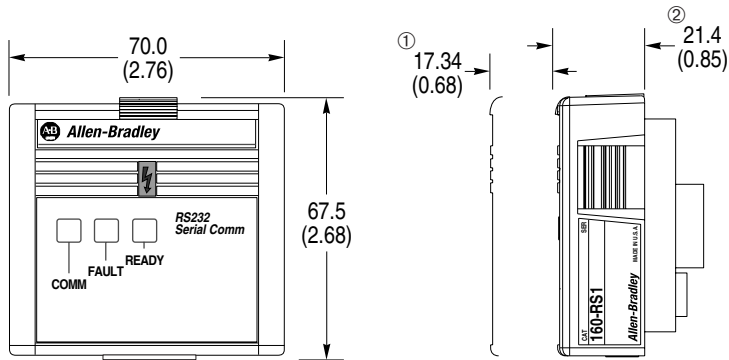

- ① Required for module removal.
- ② Module adds this dimension to the overall drive depth.

Remote Keypad Module

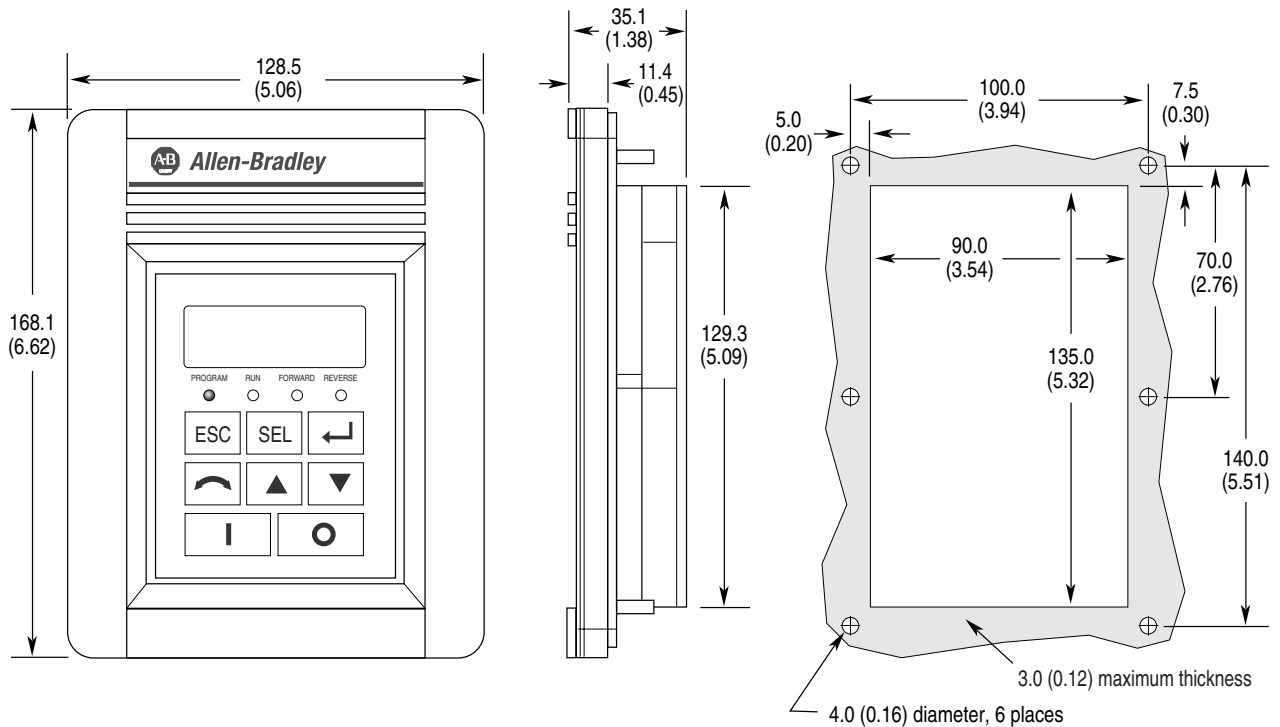

Standard Drives Program

Communication Module Specifications

Specification	DeviceNet (160-DN2)	RS232 (160-RS1)	Profibus (160-PD1)	Interbus (160-IB1)
Electrical				
Supply Voltage	Network Supply Voltage 11-25V DC	Supplied by drive	Supplied by drive	Supplied by drive
Power Consumption	1 Watt	1.25 Watts Maximum	1.25 watts maximum	1.25 watts maximum
Network Input Current	40 mA Maximum	NA	NA	NA
Communications				
Baud Rates	125, 250, 500 KBPS	1200, 2400, 4800, 9600 BPS	Autobaud 9.Kb to 12Mb	500Kb
Checksum	NA	BCC or CRC	NA	NA
Protocol	DeviceNet	DF1 Point to Point, DF1 Multidrop	Profibus -DP	Interbus S DRIVECOM 20 (21)
Explicit Peer-to-Peer Messaging	No	NA	NA	NA
I/O Peer-to-Peer Messaging	No	NA	NA	NA
Configuration Consistency Value	Yes	NA	NA	NA
Faulted Node Recovery	Yes	NA	NA	NA
Master/Scanner	No	NA	No	No
I/O Slave Messaging	Yes	NA	Yes	Yes
Slave Telegram	NA	NA	Yes	Yes
Environmental				
Ambient Operating Temperature	0 to 50 degrees C (32 to 122 degrees F)	0 to 50 degrees C (32 to 122 degrees F)	0 to 50 degrees C (32 to 122 degrees F)	0 to 50 degrees C (32 to 122 degrees F)
Ambient Storage Temperature	-40 to 85 degrees C (-40 to 185 degrees F)	-40 to 85 degrees C (-40 to 185 degrees F)	-40 to 85 degrees C (-40 to 185 degrees F)	-40 to 85 degrees C (-40 to 185 degrees F)
Relative Humidity	0 to 95% non-condensing	0 to 95% non-condensing	0 to 95% non-condensing	0 to 95% non-condensing
Vibration	1.0 G Operational, 2.5 G Non-Operational	1.0 G Operational, 2.5 G Non-Operational	1.0 G Operational, 2.5 G Non-Operational	1.0 G Operational, 2.5 G Non-Operational
Shock	15.0 G Operational, 30.0 G Non-Operational	15.0 G Operational, 30.0 G Non-Operational	15.0 G Operational, 30.0 G Non-Operational	15.0 G Operational, 30.0 G Non-Operational
Vibration	1,000 meters (3,300 feet) without derating	1,000 meters (3,300 feet) without derating	1,000 meters (3,300 feet) without derating	1,000 meters (3,300 feet) without derating

Display Parameter Descriptions

Parameter Number	Parameter Name	Description	Units
1	Output Frequency	0.0 to 240.0 Hz	0.1 Hz
2	Output Voltage	0 to max voltage	1 Volt
3	Output Current	0 to 2 times drive rated output current in units of 0.01A	0.01 Amps
4	Output Power	0 to 2 times drive rated output power in units of 0.01kW	0.01 kW
5	Bus Voltage	0V to 410V for 230V controllers, 0V to 815V for 460V controllers	1 Volt
6	Frequency Command	0.0 to 240.0 Hz	0.1 Hz
7	Last Fault	Retains faults for troubleshooting	Numeric Value
8	Heatsink Temperature	69 to 150 degrees C (156 to 302 degrees F)	1 Degree C
9	Controller Status	Running, forward, accelerating, decelerating	Binary Number
10	Controller Type	Used by Rockwell Automation field service personnel	Numeric Value
11	Control Version	Displays firmware version	Numeric Value
12	Input Status	Displays the status of start, stop, and reverse discrete inputs	Binary Number
13	Power Factor Angle	0.0 to 90.0 degrees	0.1 Degrees
14	Memory Probe Display	Used by Rockwell Automation field service personnel	Numeric Value
15	Preset Status	Displays the status of preset speed discrete inputs	Binary Number
16	Analog Input	Displays the analog input as a percent of full scale	0.1%
17	Fault Buffer 0	Stores the last fault that occurred	Numeric Value
18	Fault Buffer 1	Stores the second most recent fault that occurred	Numeric Value
19	Fault Buffer 2	Stores the third most recent fault that occurred	Numeric Value

Standard Drives Program

Program Parameter Descriptions

Parameter Number	Parameter Name	Description	Factory Default
30	Accel Time 1	0.0 to 600.0 seconds	10.0
31	Decel Time 1	0.1 to 600.0 seconds	10.0
32	Minimum Frequency	0 to 240 Hz	0
33	Maximum Frequency	0 to 240 Hz	60
34	Stop Mode Select	Four settings - Ramp, Coast, DC injection braking, DC Injection w/ auto shut off	Ramp
35	Base Frequency	10 to 240 Hz	60
36	Base Voltage	20 to 230V for 230V drives, 20 to 460V for 460V drives	230/460
37	Maximum Voltage	20 to 255V for 230V drives, 20 to 510V for 460V drives	230/460
38	Boost Select	8 boost settings, 4 fan/pump curves	2
39	Skip Frequency	0 to 240 Hz	240
40	Skip Frequency Band	0 to 30 Hz	0
41	Motor Overload Select	Three settings - No derating, Min derating, Max derating	No derating
42	Motor Overload Current	25 to 200% of drive rated current in units of 0.01 amps	115
43	Current Limit	1 to 180% of drive rated current	150
44	DC Hold Time	0 to 25 seconds	0.0
45	DC Hold Voltage	0 to 115V	0
46	Input Mode	Configurable terminal block provides 10 different control schemes	Three-wire
47	Output Configure	11 different settings for a variety of drive status conditions	0
48	Output Threshold	0 to 815	0
49	PWM Frequency	2.0 to 8.0 kHz	4.0
50	Restart Tries	0 to 9	0
51	Restart Time	0.5 to 300.0 seconds	10.0
52	DB Enable	Used to set percent duty cycle for external dynamic braking	Disable
53	S-Curve	0 to 100% accel/decel smoothing	0
54	Clear Fault	Resets faults	0
55	Memory Probe Address	Used by Rockwell Automation personnel	0
56	Reset Functions	Used to reset drive to factory default settings or update input mode	0
57	Program Lock	Protects user settings	0
58	Internal Frequency	0.0 to 240.0 Hz	60
59	Frequency Select	Selects source of frequency (internal or external)	External
60	Zero Offset	Used to add or subtract any system offset to analog input	0
61	Preset Frequency 0	0.0 to 240.0 Hz	3
62	Preset Frequency 1	0.0 to 240.0 Hz	20
63	Preset Frequency 2	0.0 to 240.0 Hz	30
64	Preset Frequency 3	0.0 to 240.0 Hz	40
65	Preset Frequency 4	0.0 to 240.0 Hz	45
66	Preset Frequency 5	0.0 to 240.0 Hz	50
67	Preset Frequency 6	0.0 to 240.0 Hz	55
68	Preset Frequency 7	0.0 to 240.0 Hz	60
69	Accel Time 2	0.1 to 600.0 seconds	20
70	Decel Time 2	0.0 to 600.0 seconds	20
71	IR Compensation	0 to 150%	50
72	Slip Compensation	0.0 to 5.0 Hz	2
73	Reverse Disable	Disables Reverse Input	0
74	Analog Select	Used to select between unipolar and bipolar inputs	0
75	Analog Input Minimum	Sets the percent of analog input to represent Minimum Frequency	0
76	Analog Input Maximum	Sets the percent of analog input to represent Maximum Frequency	100
78	Compensation	Compensates for Motor Instability or Resonance	0
79	Software Current Trip	Software instantaneous current trip	0
80	Stall Fault Time	Selects amount of time the drive is in a stall condition prior to a fault occurring	0
81	PI Proportional Gain	Proportional Response of PI Regulator	0.01
82	PI Integral Gain	Integral Gain of PI Regulator	0.01
83	PI Process Reference	PI will regulate to this setpoint value	0
84	PI Dead Band	PI will ignore errors less than this value	0

Standard Drives Program – 160Z

Catalog Number Description

160Z –	AA02	F	S	N	N ^①	N
Bulletin Number	Drive Rating (must be specified)	Enclosure Rating (must be specified)	Control Method (must be specified)	Filter Option (must be specified)	Communication (Future Option)	Motor (Optional)

Product Selection





	Input Voltage Rating	Drive Rating			Catalog Number	
		kW	HP	Output Current Rating	without Motor ^②	with Integral CE Filter
	200-240V, 50/60 Hz, Three-Phase	0.37	0.5	2.3A	160Z-AA02FSNNN	—
		0.55	0.75	3A	160Z-AA03FSNNN	—
		0.75	1	4.5A	160Z-AA04FSNNN	—
		1.5	2	8A	160Z-AA08FSNNN	—
		2.2	3	12A	160Z-AA12FSNNN	—
	380-460V, 50/60 Hz, Three-Phase	0.37	0.5	1.2A	160Z-BA01FSNNN	160Z-BA01FSFNN
		0.55	0.75	1.7A	160Z-BA02FSNNN	160Z-BA02FSFNN
		0.75	1	2.3A	160Z-BA03FSNNN	160Z-BA03FSFNN
		1.5	2	4A	160Z-BA04FSNNN	160Z-BA04FSFNN
		2.2	3	5.2A	160Z-BA06FSNNN	160Z-BA06FSFNN
		4	5	8.1A	160Z-BA10FSNNN	160Z-BA10FSFNN

① When using 160Z as wall mount, communication modules should be ordered as separate options. See page 20.

② For 160Z drives mounted on motors, consult factory.

Standard Drives Program – 160Z

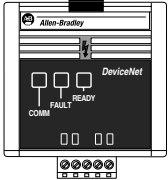
Operator Interface^① & Communication Devices

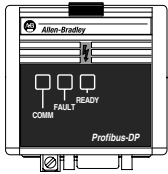
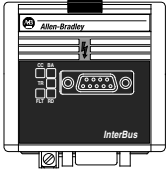
		Accessory	Catalog No.
	Remote Keypad Module 160-P2	Remote Keypad Module Module for remote mounting. Has program, monitor and operator interface capability.	160-P2
	CopyCat Keypad Module 160-P3	CopyCat Keypad Module Hand held module with upload/download capability to program, monitor and control drive.	160-P3
	DeviceNet Communication Module 160-DN2	Cables ^② Connects the 160Z to either the Remote or CopyCat Keypad Module. - 1 meter cable, locking each end - 3 meter cable, locking each end - 5 meter cable, locking each end	160Z-C10 160Z-C30 160Z-C50
	RS-232 Serial Communication Module 160-RS1		
	Profibus Communication Module 160-PD1	Communication Modules and Accessories Allow control and monitoring of parameters via the networks listed below. These modules can be mounted inside the 160Z. - DeviceNet™ - RS-232 Serial Communication - Profibus - Interbus - RS232 Communication Terminal Block - Profibus Communication Terminal Block - Interbus In/Out Communication Terminal Block - Interbus Side Metal plate (5 holes)	160-DN2 ^③ 160-RS1 160-PD1 160-IB1 160Z-RTB 160Z-PTB 160Z-ITB 160Z-ISM
	Interbus Communication Module 160-IB1		
		Motor Adapters - NEMA motor, 0.5 - 2 HP ^④ - NEMA motor, 3 - 5 HP ^④ - SEW, IEC Motor, 0.37-1.5 kW ^⑤ - SEW, IEC Motor, 2.2 kW ^⑤ - SEW, IEC Motor, 3.7 kW ^{⑤⑥}	160Z-ABN1 160Z-ABN2 160Z-SEW1 160Z-SEW2 160Z-SEW3
		Hardware - Power cable glands - Motor cable glands, wall mounting only - Communication and I/O cable glands	160Z-G25 160Z-G20 160Z-G16
		Accessories - Debris cover, motor mount - Debris cover, wall mount - Fan replacement kit - Spare gasket kit (includes all gaskets) - Wall mounting kit (includes one 160Z-G20) - Wall mount adapter	160Z-DC 160Z-DCW 160Z-FRK 160Z-GSK 160Z-WMK 160Z-WMA
		DriveExplorer™ Software Windows based software package that provides an intuitive means for monitoring or configuring Allen-Bradley drives and communication adapters.	See Publication 9306-PL001A-EN-P.

- ① 160-P1 is not compatible with 160Z drives.
 ② 160-RPA is not required with 160Z drives. 160-RPA circuitry is included as standard.
 ③ Includes 10 pin DeviceNet Connector.
 ④ For mounting with Allen-Bradley 1329RS motors, cast iron, severe duty.
 ⑤ For mounting with SEW, D-Type IEC motors.

⑥ Maximum continuous output is 3.0 kW at 40°C and 4 kHz, 3.7 kW at 35°C and 2 kHz.

Standard Drives Program – 160Z

Specifications

160Z Drive Ratings							
IP20 Catalog Number	Output Ratings			Input Ratings		Dynamic Braking Torque	
	Three-Phase Input, 50/60 Hz	kW	HP	Output Current	Operating Voltage Range	kVA	Without External Resistor
200 - 240V							
160Z-AA02	0.37	0.5	2.3A	180-265V	1.4	100%	–
160Z-AA03	0.55	0.75	3.0A	180-265V	1.8	100%	–
160Z-AA04	0.75	1	4.5A	180-265V	2.7	100%	200%
160Z-AA08	1.5	2	8.0A	180-265V	4.0	50%	150%
160Z-AA12	2.2	3	12.0A	180-265V	7.1	50%	115%
380 - 460V							
160Z-BA01	0.37	0.5	1.2A	340-506V	1.4	100%	–
160Z-BA02	0.55	0.75	1.7A	340-506V	2.0	100%	–
160Z-BA03	0.75	1	2.3A	340-506V	2.7	100%	200%
160Z-BA04	1.5	2	4.0A	340-506V	4.7	50%	150%
160Z-BA06	2.2	3	5.2A	340-506V	7.1	50%	115%
160Z-BA10	4.0	5	8.1A	340-506V	12.3	20%	100%

Input/Output Ratings (All Drive Ratings)	
Output Voltage	Adjustable from 0V to input voltage
Output Frequency	0 to 240 Hz - Programmable
Efficiency	97.5% (Typical)
Transient Protection	Standard 6kV (Series C drives)
Environmental Specifications (All Drive Ratings)	
Enclosure	IP 65 (NEMA Type 4X)
Ambient Temperature IP 20 IP 66 (NEMA Type 12/4/4X)	0 to 50 degrees C (32 to 122 degrees F) 0 to 40 degrees C (32 to 104 degrees F)
Storage Temperature	–40 to 85 degrees C (–40 to 185 degrees F)
Relative Humidity	Condensing, Dropping Water, Hose Down for maintenance with water, soaped water or acid agents
Vibration	1.0 G Operational - 2.5 G Non-operational
Shock	15 G Operational - 30 G Non-operational
Altitude	1,000 meters (3,300 feet) without derating
Control Inputs	
Control Input Type	Dry Contact Inputs - Drive has an internal 12 volt power supply that provides 10 mA typical current flow. 24V Inputs - 24V DC interface on Regulator Board (selectable through jumpers) allows use of 24V DC sinking inputs.
Start, Stop, Forward/Reverse	Configurable inputs for 2 or 3 wire control
Control Inputs	
Analog Input (4 to 20mA)	Input impedance 250 ohms
Analog Input (-10 to +10V DC)	Input impedance 100k ohms
External Speed Potentiometer	1k to 10k ohms, 2 Watt minimum
PI Control	Parameter 46, setting 9 provides PI Control function
SW1, SW2	Parameter 46, setting 8 provides 4 preset speeds and 2 accel/decel times

Standard Drives Program – 160Z

Specifications, Continued

Control Output	
Programmable Output (form C relay contact)	Resistive Rating: 0.4A at 125V AC, 0.2A at 230V AC, 2A at 30V DC Inductive Rating: 0.2A at 125V AC, 0.1A at 230V AC, 1A at 30V DC Programmable for eleven different functions
Control Features	
PWM Algorithm	Sine weighted PWM with harmonic compensation
Switching Device (3-Phase Output)	IGBT (Insulated Gate Bipolar Transistor)
V/Hz Ratio	Programmable
Carrier Frequency	Adjustable from 2 kHz to 8 kHz in 100 Hz increments (factory default is 4 kHz)
DC Boost	Adjustable - Select from a family of boost curves
Current Limiting	Trip free operation, coordinated for drive and motor protection. Programmable from 1% to 180% of drive Output Current.
Motor Protection	I ² t overload protection - 150% for 60 seconds, 200% for 30 seconds (Provides Class 10 overload protection)
Overload Pattern #0	Flat response over speed range (no speed compensation)
Overload Pattern #1	Speed compensation below 25% of base speed
Overload Pattern #2	Speed compensation below 100% of base speed
Acceleration/Deceleration Time(s)	0.1 to 600 seconds
S-Curve Accel/Decel Time(s)	0 to 100% of accel/decel time - not to exceed 60 seconds
Stopping Modes	4 modes (programmable)
Ramp to Stop	0.1 to 600 seconds
Coast	Stops all PWM output
DC Injection Brake	Applies DC voltage to the motor for 0 to 25 seconds
DC Injection Braking w/ Auto Stop	Applies DC voltage to the motor for 0 to 25 seconds with Auto Shutoff
Protective Features	
Overcurrent	200% hardware limit, 300% instantaneous fault
Excessive Temperature	Embedded temperature sensor trips if heatsink temperature exceeds 95 degrees C (203 degrees F)
Over Voltage Drive Rated Input = 200-240V AC Drive Rated Input = 380-460V AC	DC Bus voltage is monitored for safe operation Overvoltage trip occurs at 400V DC bus voltage (equivalent to 290V AC incoming line voltage). Overvoltage trip occurs at 800V DC bus voltage (equivalent to 575V AC incoming line voltage).
Under Voltage Drive Rated Input = 200-240V AC Drive Rated Input = 380-460V AC	DC Bus voltage is monitored for safe operation Undervoltage trip occurs at 210V DC bus voltage (equivalent to 150V AC incoming line voltage). Undervoltage trip occurs at 390V DC bus voltage (equivalent to 275V AC incoming line voltage).
Control Ride Through	Minimum ride through is 0.5 seconds - typical value 2 seconds
Ground Fault	Protection in both Start and Run Mode
Faultless Ride Through	100 milliseconds
Output Short Circuit	Any output phase to phase short
Programming	
Programmer Display Type Keypad Controls	Optional - External Keypad Module Two Digit Parameter Number and Four Digit Value Speed, Run, Stop and Direction

Standard Drives Program – 160Z

Approximate Dimensions

Dimensions are shown in millimeters (inches). Dimensions are not to be used for manufacturing purposes.

Wall Mount

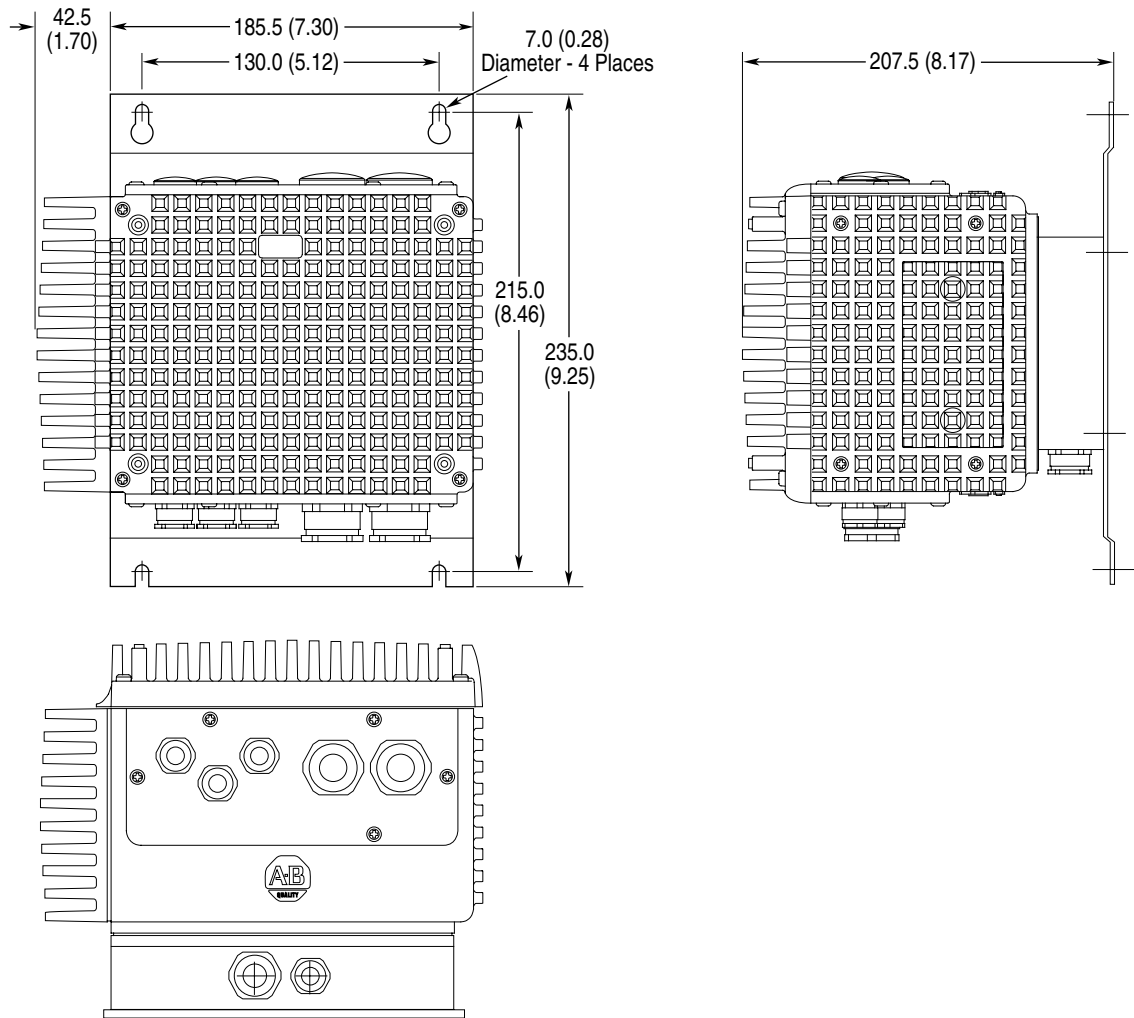

Standard Packaged Drives

Ordering Instructions

The Standard Packaged Drive Program allows users to create drive packages based on their specific needs. A complete drive package may be specified by assembling a single catalog number string that includes a base drive, enclosure and all required options.

Ordering Instructions:

- Select basic Catalog Number based on application requirements (i.e. Voltage, Horsepower, Control Model and Enclosure Ratings).
For example: a 200-240V AC, three-phase, 0.37 kW (0.5 HP), analog signal follower model and a IP66 (NEMA Type 4/12) enclosure. The catalog number is: **160-AA02SF1-AF**.
- Select Enclosure Options and follow the Option Rules. For example: the catalog number with a fused disconnect switch and Start-Stop pushbuttons is: **160-AA02SF1-AF- DS-D17**.

Compliance certifications include:

	CE (Europe)	
UL/cUL (U.S. & Canada)	Low Voltage Directive 73/23/EEC	EMC Directive 89/336/EEC
UL508C	EN60204-1	EN 61800-3
CAN/CSA C222 No. 14	EN50178	EN 50081-2
		EN 50082-2
C-Tick (Australia)		
AS/NZS2064.1		

Important: When the "EMC" option is selected, the product will ship with an RFI "RF" type filter. If the "EMC" option is not selected, reference the *Bulletin 160 Series C User Manual* for proper installation instructions.

Custom Configured Drives Program

Drive packages that cannot be ordered via a catalog number can be customized to meet customer requirements for specific options such as special enclosure sizes and colors, terminal blocks, wire type, etc.

Catalog Number Description

160 – AA02SF1 – AF – DS-D17

Bulletin Number

Drive Rating and Control Model Type
(must be specified)

Enclosure Rating
(must be specified)

Options
(specify as needed)

Product Selection

Input Voltage Rating	Drive Ratings			Catalog Number			
	kW	HP	Output Current Rating	IP66 (NEMA 4/12)		IP66 (NEMA 4X - 304 Stainless Steel)	
				Analog Signal Follower Model	Preset Speed Model	Analog Signal Follower Model	Preset Speed Model
200-240V 50/60 Hz Single-Phase	0.37	0.5	2.3A	160S - AA02SF1-AF	160S - AA02PS1-AF	160S-AA02SF1-AS	160S - AA02PS1-AS
	0.55	0.75	3.0A	160S - AA03SF1-AF	160S - AA03PS1-AF	160S-AA03SF1-AS	160S - AA03PS1-AS
	0.75	1	4.5A	160S - AA04SF1-AF	160S - AA04PS1-AF	160S-AA04SF1-AS	160S - AA04PS1-AS
	1.5	2	8.0A	160S - AA08SF1-AF	160S - AA08PS1-AF	160S-AA08SF1-AS	160S - AA08PS1-AS
200-240V 50/60 Hz Three-Phase	0.37	0.5	2.3A	160 - AA02SF1-AF	160 - AA02PS1-AF	160-AA02SF1-AS	160 - AA02PS1-AS
	0.55	0.75	3.0A	160 - AA03SF1-AF	160 - AA03PS1-AF	160-AA03SF1-AS	160 - AA03PS1-AS
	0.75	1	4.5A	160 - AA04SF1-AF	160 - AA04PS1-AF	160-AA04SF1-AS	160 - AA04PS1-AS
	1.5	2	8.0A	160 - AA08SF1-AF	160 - AA08PS1-AF	160-AA08SF1-AS	160 - AA08PS1-AS
	2.2	3	12.0A	160 - AA12SF1-AF	160 - AA12PS1-AF	160-AA12SF1-AS	160 - AA12PS1-AF
380-460V 50/60 Hz Three-Phase	0.37	0.5	1.2A	160 - BA01SF1-AF	160 - BA01PS1-AF	160-BA01SF1-AS	160 - BA01PS1-AS
	0.55	0.75	1.7A	160 - BA02SF1-AF	160 - BA02PS1-AF	160-BA02SF1-AS	160 - BA02PS1-AS
	0.75	1	2.3A	160 - BA03SF1-AF	160 - BA03PS1-AF	160-BA03SF1-AS	160 - BA03PS1-AS
	1.5	2	4.0A	160 - BA04SF1-AF	160 - BA04PS1-AF	160-BA04SF1-AS	160 - BA04PS1-AS
	2.2	3	6.0A	160 - BA06SF1-AF	160 - BA06PS1-AF	160-BA06SF1-AS	160 - BA06PS1-AS
	4.0	5	10.5A	160 - BA10SF1-AF	160 - BA10PS1-AF	160-BA10SF1-AS	160 - BA10PS1-AS

Standard Packaged Drives

Factory Installed Enclosure Options

Description	Option Code ^⑩	Cannot be used with
Operator Interface		
DeviceNet Module ^①	- DN2C	P1C, RS1C, Ready/Fault, RPAC, -P2C, -D17
Serial Communication Module	- RS1C	DN2C, PIC, Ready/Fault, RPAC, -P2C, -D17
Profibus Module (Drive Mounted)	- PDIC	DN2C, PIC, RS1C, Ready Fault, RPAC, P2C, D17, IB1C
Interbus Module (Drive Mounted)	- IB1C	P1C, RS1C, Ready Fault, RPAC, P2C, D17, PR1C, DN2C
DeviceNet I/O Relay 24 DC Input / Replay Output with 5 point DeviceNet Connector	- DNRC ^⑦	
Ready/Fault Panel	- ②	DN2C, P1C, RS1C, RPAC, -P2C
Program Keypad Module (Drive Mounted)	- P1C	DN2C, RS1C, Ready/Fault, RPAC, -P2C, D17
Remote Programming Adapter	- RPAC	DN2C, RS1C, Ready/Fault, P1C, P2C, -D17
Remote Keypad Module	- P2C ^{④⑦}	DN2C, RS1C, Ready/Fault, P1C, RPAC, -D17, D33
Fused Disconnect Switch (Class J Fuses)	- DS	
Cover Mounted Devices:		
“Hand-Off-Auto” Selector Switch	- D13	- D17, D33, MX12, MX19
“Start-Stop” Push Buttons	- D17	- D13, D33, MX12, MX19, DN2C, P1C, RS1C, RPAC, P2C
“Forward/Reverse” Selector Switch	- D32 ^⑨	- MX12, MX19
“Local/Remote” Selector Switch	- D33	- D13, D17, MX12, MX19
White “Drive Run” Pilot Light ^③	- D35	- D36, MX12, MX19
Red “Drive Fault” Pilot Light ^③	- D36	- D35, MX12, MX19
“Speed” Potentiometer	- D61	- MX12, MX19, All Preset Speed Models
“Local/Remote” & “Local Control Off/Run Forward” 800T Selector Switches	- MX12	- D13, D17, D32, D33, D35, D36, D61, AS, MX19
“Local/Off/Remote” 800T Selector Switch with One N.O. Interposing Relay	- MX19	- D13, D17, D32, D33, D35, D36, D61, MX12, MX14, 45, AS
Control Interface Cards:		
24V DC Interface Card for Analog Drive	- DMSF1C	DMPS1C, LTN120, All Preset Speed Models
24V DC Interface Card for Preset Speed Drive	- DMPS1C	DMFS1C, LTN120, All Analog Models
120V AC Interface Module for Analog and Preset Speed Drives	- LNT120 ^⑧	DMPS1C, DMSF1C
DeviceNet Enclosure Mounted Connector Options ^⑤ :		
Nema 4/12 5 pin connector side mounted	- DN2C ^⑥	DN2C, DNBC1, DNBC2, P1C, RS1C, RPAC, P2C, STD READY FAULT
Nema 4x 5 pin connector side mounted	- DN2C ^⑥	DN2C, DNBC1, DNBC2, P1C, RS1C, RPAC, P2C, STD READY FAULT
Nema 4/12 5 pin connector bottom mounted	- DNBC1 ^⑥	DN2C, DNBC2, DNBC2, P1C, RS1C, RPAC, P2C, STD READY FAULT
Nema 4x 5 pin connector bottom mounted	- DNBC2 ^⑥	DN2C, DNBC2, DNBC1, P1C, RS1C, RPAC, P2C, STD READY FAULT
Electro Magnetic Compatibility	- EMC ^⑦	-LTN120
Motor Brake Option:		
Motor Brake Contactor and Surge Suppressor (100M cont. 24V powered off DeviceNet Option)	- MX14 ^{⑥⑦}	D35, D36, MX19, P1C, RS1C, RPAC, P2C, Ready Fault

① Includes 10 point DeviceNet Connector.

② If a (-P1C), (-DN2C), (RS1C), (RPAC) or (P2C) is not specified, the drive is supplied with a factory installed “Ready/Fault” indicating panel as standard.

③ 120V AC Separate Control Power Required.

④ Remote Keypad Module option includes the RPA and cable.

⑤ 5 pin DeviceNet Connectors are Brad Harrison type. Female connector #1A5000-34 User supplied. See Dimensions/locations page 27.

⑥ DN2C option must be selected. See page 27 for connector locations.

⑦ Enclosure dimensions with or without disconnect: 0.5-2 HP 8.44W x 17H x 9.15D; 3 HP 9.61W x 16.5H x 9.46D

⑧ Option is not CE/C-Tick.

⑨ When catalog string contains a communication module, D32 must be used with D33 or except with option P2C. When used with option P2C, must be used with D13.

⑩ For pricing information refer the Bulletin 160 Price Sheet.

Option Rules

Option	Description
Maximum Number of Cover Devices	0.37-1.5 kW (0.5-2 HP) without a disconnect or Remote Keypad Module or MX14 or EMC is 4.
	2.2-4 kW (3-5 HP) w/o a disconnect or Remote Keypad Module and all drives with a disconnect, MX14 or EMC is 5.
	0.37-4.0 kW (3-5 HP) with the Remote Keypad Module is 3.
	i.e. Start-Stop (D17) = 2 Cover Devices Forward-Reverse (D32) = 1 Cover Device White Run Pilot Light (D35) = 1 Cover Device = 4 Total
Factory Installed Enclosure Option Catalog Configuration	When ordering, build the catalog string in the following manner: Bulletin number, drive rating, control model, enclosure type and options. Note: Options are to be configured in alpha-numeric sequence.

Standard Packaged Drives

Approximate Dimensions for 160 NEMA Type 4/12 & 4X Stainless Steel Enclosures

Figure 1

0.37 kW-0.75 kW (0.5-1 HP), Single-Phase, 200-240V AC (without DS, P2C, LTN120, MX14 or EMC)
 0.37 kW-1.5 kW (0.5-2 HP), Three-Phase, 200-240V AC and 380-460V AC (without DS, P2C, LTN120, MX14 or EMC)
 .37 - .75 without the following options: DS, P2C, LTN120, MX14.

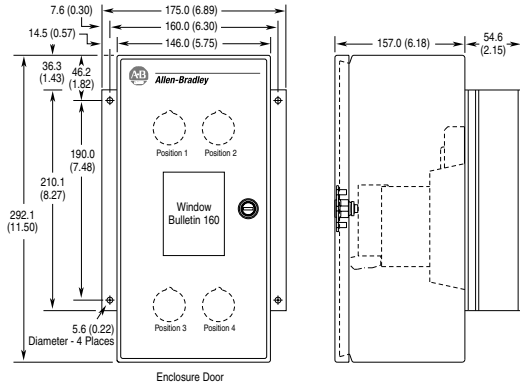

Figure 2

0.37 kW-0.75 kW (0.5-1 HP), Single-Phase, 200-240V AC (without DS, P2C, LTN120, MX14 or EMC)
 0.37 kW-1.5 kW (0.5-2 HP), Three-Phase, 200-240V AC and 380-460V AC (without DS, P2C, LTN120, MX14 or EMC)
 with the following options: DS, P2C, LTN120, MX14.

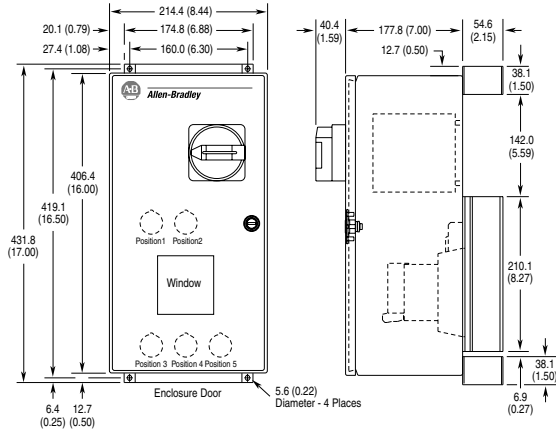
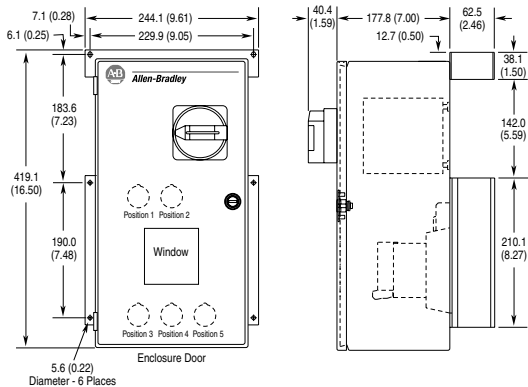

Figure 3

2.2 kW (3 HP), Three-Phase, 200-240V AC and 380-460VAC (with and without DS or with P2C, LTN120, MX14 or EMC)



Standard Packaged Drives

Approximate Dimensions, Continued

Dimensions are shown in millimeters (inches). Dimensions are not to be used for manufacturing purposes.

Figure 4

1.5 kW (2 HP), Single-Phase, 200-240V AC (with DS, P2C, LTN120, MX14 or EMC)
 4 kW (5 HP), Three-Phase, 200-240V/380-460V AC (with DS, P2C, LTN120, MX14 or EMC)

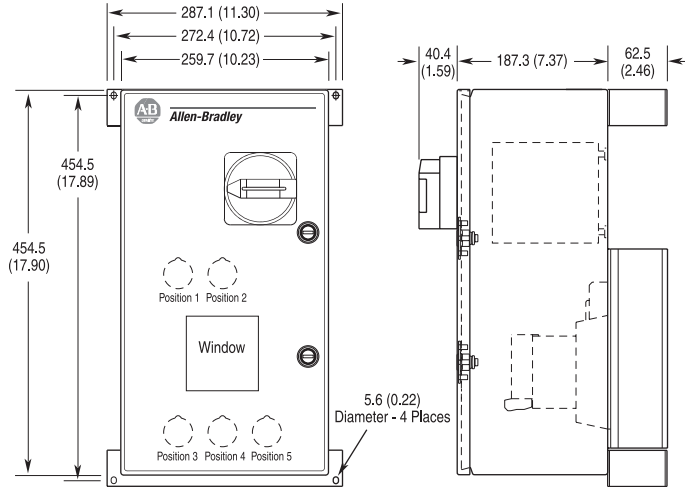

DeviceNet Connector Option Locations

Figure 5

DNCS1 and DNCS2

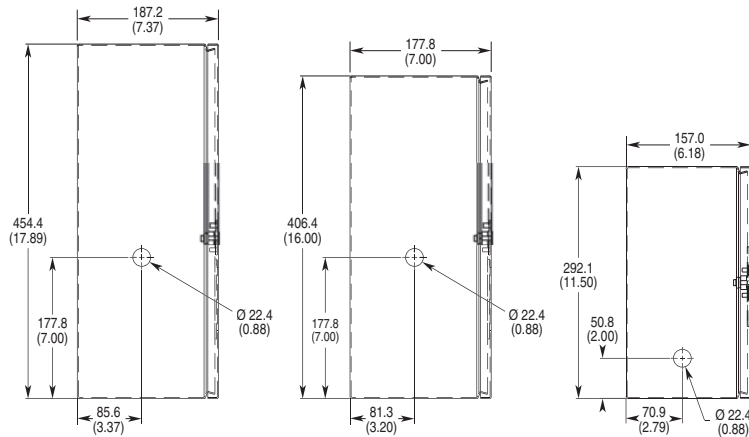

DNBC1 and DNBC2

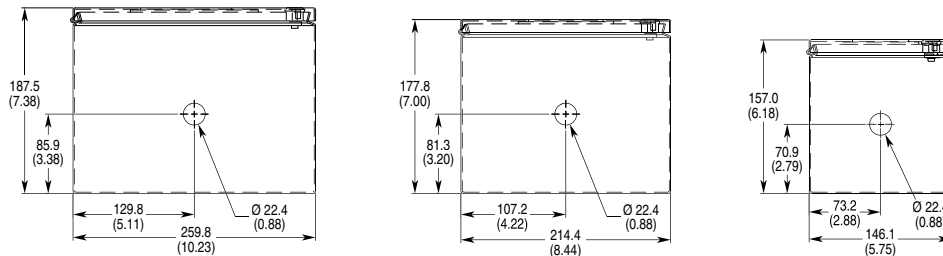

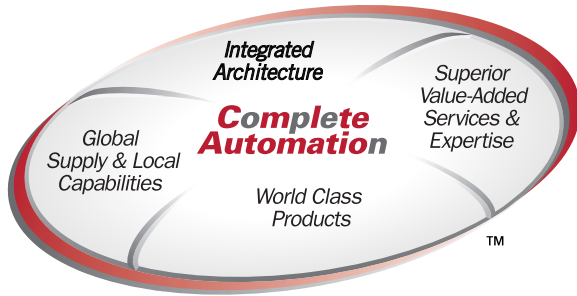

The Allen-Bradley Bulletin 160 Smart Speed Controller (SSC) is a world class product that provides the application flexibility needed to meet today's changing plant floor environment. Its simplistic design will help save time and money in set-up, integration and maintenance of your automation system.

For Allen-Bradley drives support, there are specialists at local sales offices and distributor locations across North America and around the world. We also offer global technical services, specializing in a full spectrum of value-added services and expertise to help simplify maintenance and enhance productivity.

Rockwell Automation is committed to helping you meet ever-changing customer demands for more, less expensive product in less time. Our capabilities enable us to become your "Complete Automation™" partner.

SSC, DriveExplorer, Complete Automation and the Complete Automation graphic are trademarks of Rockwell Automation.
Windows is a registered trademark of the MicroSoft Corporation.
DeviceNet is a trademark of the Open DeviceNet Vendor Association.

www.rockwellautomation.com

Corporate Headquarters

Rockwell Automation, 777 East Wisconsin Avenue, Suite 1400, Milwaukee, WI, 53202-5302 USA, Tel: (1) 414.212.5200, Fax: (1) 414.212.5201

Headquarters for Allen-Bradley Products, Rockwell Software Products and Global Manufacturing Solutions

Americas: Rockwell Automation, 1201 South Second Street, Milwaukee, WI 53204-2496 USA, Tel: (1) 414.382.2000, Fax: (1) 414.382.4444

Europe/Middle East/Africa: Rockwell Automation SA/NV, Vorstlaan/Boulevard du Souverain 36, 1170 Brussels, Belgium, Tel: (32) 2 663 0600, Fax: (32) 2 663 0640

Asia Pacific: Rockwell Automation, 27/F Citicorp Centre, 18 Whitfield Road, Causeway Bay, Hong Kong, Tel: (852) 2887 4788, Fax: (852) 2508 1846

Headquarters for Dodge and Reliance Electric Products

Americas: Rockwell Automation, 6040 Ponders Court, Greenville, SC 29615-4617 USA, Tel: (1) 864.297.4800, Fax: (1) 864.281.2433

Europe/Middle East/Africa: Rockwell Automation, Brühlstraße 22, D-74834 Elztal-Dallau, Germany, Tel: (49) 6261 9410, Fax: (49) 6261 17741

Asia Pacific: Rockwell Automation, 55 Newton Road, #11-01/02 Revenue House, Singapore 307987, Tel: (65) 6356-9077, Fax: (65) 6356-9011

U.S. Allen-Bradley Drives Technical Support

Tel: (1) 262.512.8176, Fax: (1) 262.512.2222, Email: support@drives.ra.rockwell.com, Online: www.ab.com/support/abdrives