

# Basics for practical operation

## Motor starting

*Traditional motor starting,  
Soft starters, frequency inverters*

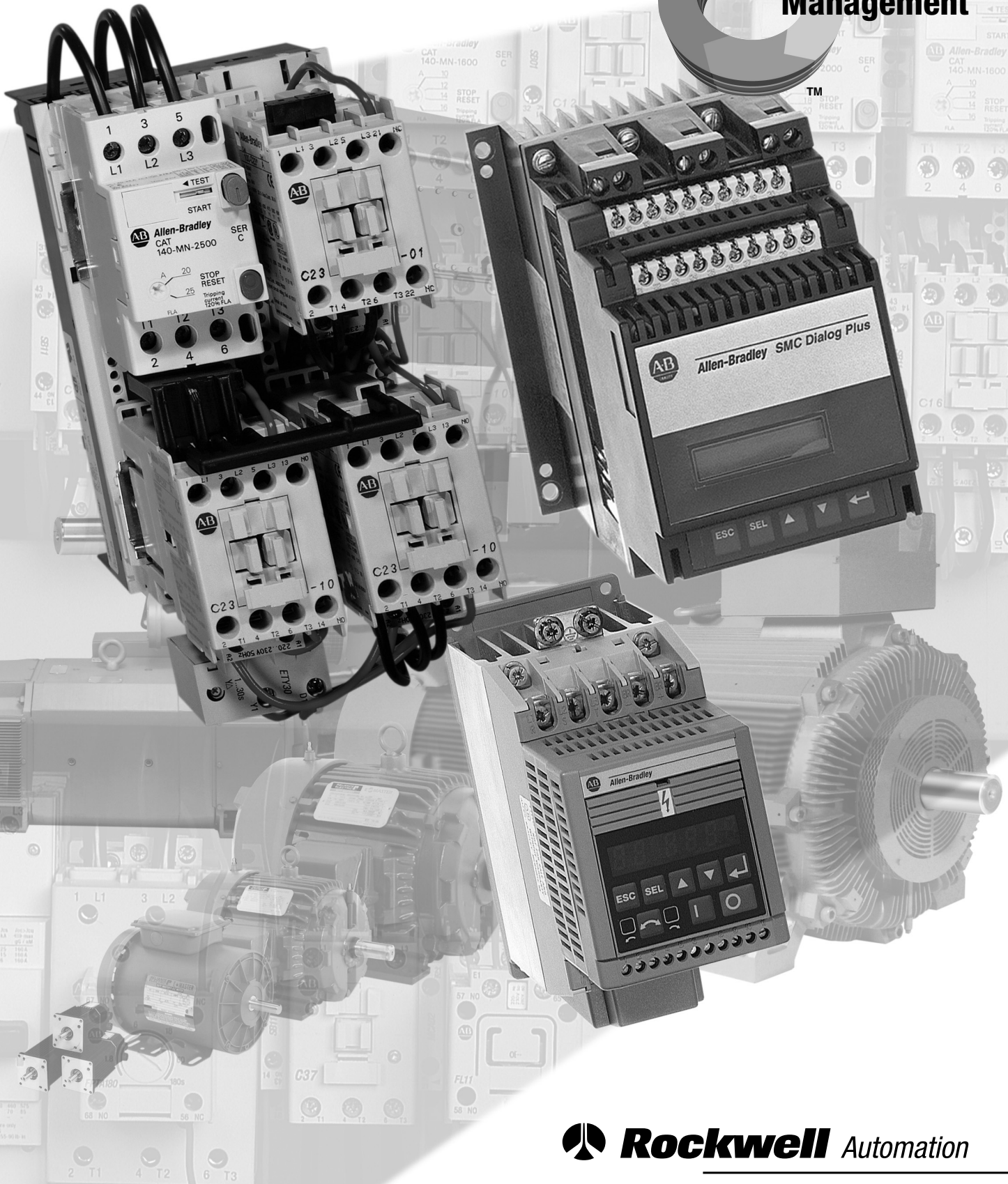

## Foreword

This technical manual for 'Motor Starting' is another publication on the subject of 'Motor Management'.

With these published fundamentals, of Motor Management, the user will have a growing reference on the performance and operational data required for design and application.

Topics covered include:

- Protection of Motor and Drive,
- Selection and Operation of Switchgear,
- Communications.

The following manuals have already been published:

- 'Three-phase Induction Motors', discusses the structure, modes, selection, and sizing of motors and
- 'Basics of Power Circuit Breakers', discusses the practical use of Motor Protective breakers.

Electric motors can be found in every production process today.

The optimal use of the drives is becoming increasingly important in order to ensure cost-effective operations. 'Motor Management' from Rockwell Automation will help you:

- to optimise the use of your systems,
- to reduce maintenance costs,
- to increase operational safety.

We hope these publications will help you find economical and efficient solutions for your applications.

Copyright © 1997 by Rockwell Automation AG

All information given represents the current level of technology available and is not legally binding.

Table of Contents

<b>1</b>	<b>Traditional motor starting</b>	<b>1.1</b>
<b>1.1</b>	<b>Star-delta-starting</b>	<b>1.1</b>
1.1.1	Normal star-delta-starting	1.1
1.1.2	Enhanced star-delta-starting	1.5
1.1.2.1	Combined star-delta-starting	1.5
1.1.2.2	Partially wound star-delta-starting	1.6
1.1.3	Uninterrupted star-delta-starting	1.6
<b>1.2</b>	<b>Auto-transformer starting</b>	<b>1.8</b>
<b>1.3</b>	<b>Starting via chokes or resistors</b>	<b>1.9</b>
1.3.1	Starting via chokes	1.9
1.3.2	Starting via resistors	1.10
<b>1.4</b>	<b>Multi-stage motors</b>	<b>1.11</b>
<b>2</b>	<b>Soft starters</b>	<b>2.1</b>
<b>2.1</b>	<b>General</b>	<b>2.1</b>
<b>2.2</b>	<b>Power starting implementation</b>	<b>2.2</b>
2.2.1	Motor torque reduction	2.3
2.2.2	Influencing the motor voltage	2.3
<b>2.3</b>	<b>Starting types</b>	<b>2.4</b>
2.3.1	Starting by means of a voltage ramp	2.4
2.3.2	Starting by means of a current limitation	2.5
2.3.3	Torque	2.5
<b>2.4</b>	<b>Soft starter types</b>	<b>2.5</b>
2.4.1	Single-phase full-wave controlled soft starter	2.6
2.4.2	Three-phase half-wave controlled soft starter	2.7
2.4.3	Three-phase full-wave controlled soft starter	2.8
<b>2.5</b>	<b>Thermal load during start</b>	<b>2.8</b>
<b>2.6</b>	<b>Advantages of soft starters</b>	<b>2.9</b>
<b>2.7</b>	<b>Benefits to the customer</b>	<b>2.9</b>
2.7.1	Mechanical	2.9
2.7.2	Electrical	2.10

<b>2.8</b>	<b>Possible Applications</b>	<b>2.10</b>
<b>2.9</b>	<b>Pump starting</b>	<b>2.11</b>
2.9.1	Current and torque development for a star-delta-starters	2.11
2.9.2	Speed development for starts with a pump soft starter	2.12
2.9.3	Comparison of torque curves	2.12
2.9.4	Flow curve during start	2.13
2.9.5	Flow curve during stop	2.13
2.9.6	Requirements for a pump soft starter	2.14
2.9.7	Application areas	2.14
<b>2.10</b>	<b>Options</b>	<b>2.14</b>
<b>3</b>	<b>Frequency Inverters</b>	<b>3.1</b>
<b>3.1</b>	<b>General</b>	<b>3.1</b>
<b>3.2</b>	<b>Structure</b>	<b>3.1</b>
3.2.1	Mains rectifiers	3.2
3.2.1.1	Principle diagram of pulsating direct voltages	3.2
3.2.2	Intermediate circuit	3.3
3.2.3	Inverters	3.3
3.2.3.1	Principle diagram of pulse width modulation	3.4
<b>3.3</b>	<b>Operational behaviour</b>	<b>3.4</b>
3.3.1	Frequency-voltage-ratio	3.4
3.3.2	Voltage increase or boost	3.5
3.3.3	Slip compensation	3.6
3.3.4	Set value	3.6
3.3.5	Compensation	3.6
3.3.6	Motor protection	3.7
3.3.7	Change of rotation and braking	3.7
<b>3.4</b>	<b>Advantages of frequency inverters</b>	<b>3.8</b>
<b>3.5</b>	<b>Radio frequency interference (RFI)</b>	<b>3.8</b>
3.5.1	General	3.8
3.5.2	Standards	3.9
3.5.3	Measures	3.10
<b>4</b>	<b>Comparing starting procedures</b>	<b>4.1</b>



### Starting Electric Motors

Due to their simplicity, robustness and cost-effectiveness, squirrel-cage motors are the preferred choice of industry. During start-up, they develop currents of up to approximately eight times the rated current and the high starting torque linked to this. The high starting currents often lead to unwelcome voltage drops in the supply network and the high starting torque put the mechanical elements under considerable strain. Therefore, the electricity companies determine limiting values for the motor starting currents in relation to the rated operational currents. The permissible values vary from network to network and depend on its load-bearing capacity. With regard to mechanics, methods are required which reduce starting torque.

Various starters and methods can be used to reduce currents and torque:

- Star-Delta-Starting
- Auto-transformer-Starting
- Starting via chokes or resistors
- Multi-stage starting
- Starting using electronic soft starters
- Starting using frequency inverters

In the following passages, the main starting methods used in practice are explained further.

## 1 Traditional motor starting

### 1.1 Star-delta starting

A difference is made between:

- Normal Star-Delta Starters
- Enhanced Star-Delta Starters
- Star-Delta Starters with uninterrupted switchover (closed transition)

#### 1.1.1 Normal star-delta starters

To enable the motor to start, the motor windings are configured in a star formation to the supply voltage. The voltage applied to the individual motor windings is therefore reduced by a factor of  $1/\sqrt{3} = 0.58$  this connection amounts to approximately 30% of the delta values. The starting current is reduced to one third of the direct starting current, i.e. typically to 2...2.5  $I_e$ .

Due to the reduced starting torque, the star-delta-connection is suitable for drives with a high inertia mass but a resistance torque which is low or only increases with increased speed. It is preferably used for applications where the drive is only put under a load after run-up, i.e. for presses, centrifuges, pumps, ventilators, etc.

# Motor Starting

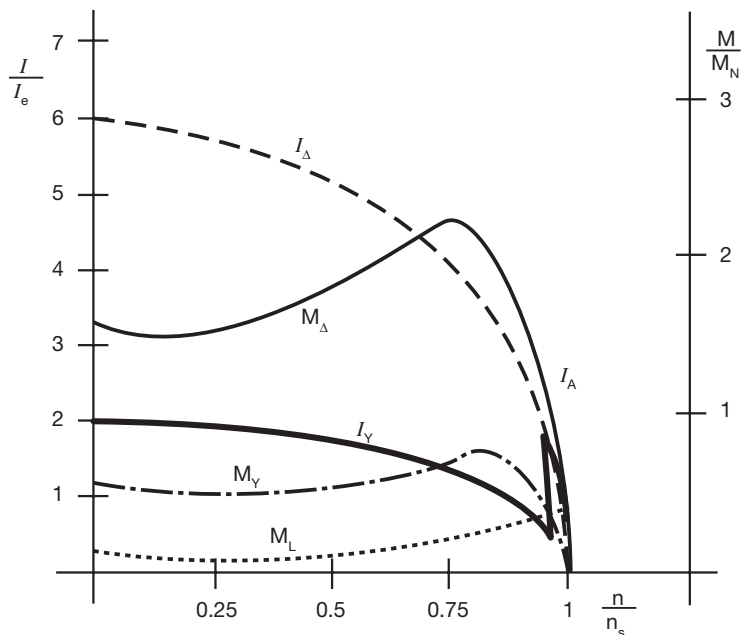

Typical Current and Torque Curve for Star-Delta-Starters

I	Motor current	n	Speed
$I_e$	Rated operating current of motor	$n_s$	Synchronous speed
$M_D$	Torque for delta connection	$M_L$	Load torque
$M_E$	Rated operating torque of motor	$I_Y$	Current in star connection
		$I_D$	Current in delta connection
		$I_A$	Current curve for star-delta start

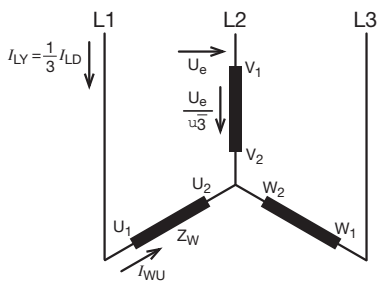

Star Connection

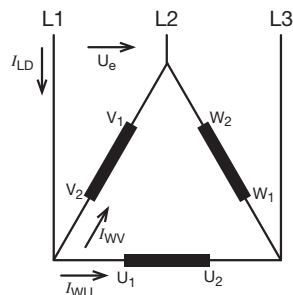

Delta Connection

Current ratios for star and delta connections.

- $I_{LY}$  Supply current for star connection
- $I_{LD}$  Supply current for delta connection
- $I_W$  Winding current
- $U_e$  Mains voltage between lines
- $Z_W$  Winding impedance

$$I_{LY} = I_{WU} = \frac{U_e}{\sqrt{3} Z_W}$$

$$\vec{I}_{L1D} = \vec{I}_{WU} + \vec{I}_{WV}$$

$$I_{LD} = I_W \sqrt{3} = \frac{U_e}{Z_W} \sqrt{3} = 3 I_{LY}$$

$$I_{LY} = \frac{1}{3} I_{LD}$$

After motor run-up, in most cases an automatic timing relay controls the switch-over from star to delta. The run-up using star connection should last until the motor has reached the approximate operational speed, so that after switching to delta, as little post-acceleration as possible is required. Post-acceleration in delta connection will instigate high currents as seen with direct-on-line starting. The duration of start in star connection depends on the motor load. During delta connection, the full mains voltage is applied to the motor windings.

To enable a switch-over from star to delta, the six ends of the motor winding are connected onto terminals. The contactors of a star-delta starter switch over the windings accordingly.

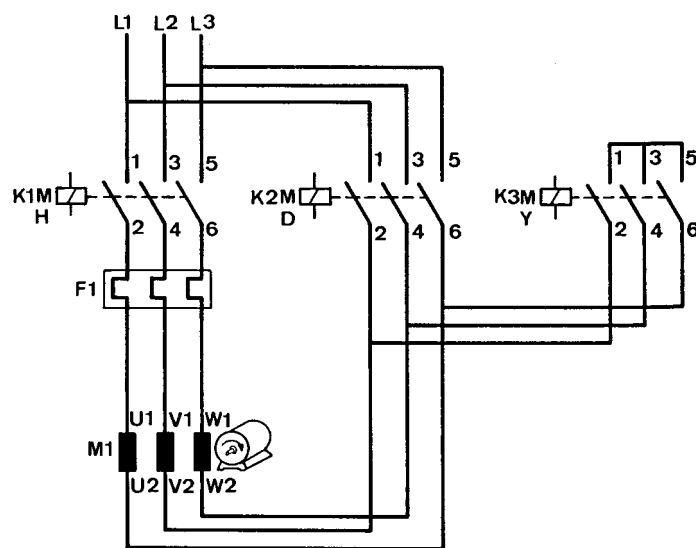

*Switch over from Star to Delta by means of Contactors*

Starting in star, the main contactor connects the mains to winding endings U1, V1, W1. The star contactor shorts winding endings U2, V2, W2. After successful run-up, the star contactor switches itself off and the delta contactor connects terminals U1/V2, V1/W2, W1/U2.

When changing from star to delta, attention has to be paid to the correct phase sequence, i.e. the correct connection of the conductors to motor and starter. Incorrect phase sequence can lead to very high current peaks during the cold switch-over pause, due to the easy torque reduction following re-start. These peaks can damage the motor windings and stress the controlgear unnecessarily. The rotation of the motor has to be considered as well.



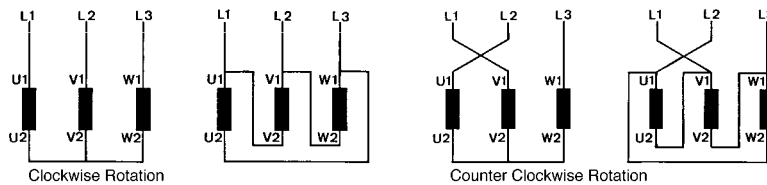

### Correct Motor Connection

A sufficient time period has to be maintained between the star contactor's de-energisation and the energisation of the delta contactor, in order to safely extinguish the star contactor's disconnecting arc before the delta contactor is energised. During a switch-over which is too fast, a short circuit may develop via the disconnecting arc. The switch over time period, however, should be just long enough for an arc disconnection, so that the speed decreases as little as possible. Special timing relays for a star-delta switch over fulfil these requirements.

### Motor Protection and Contactor Sizing

The overload relay is situated in the motor line. Therefore, the current to be adjusted is lower than the motor's rated current by a factor of  $1/\sqrt{3} = 0.58$ . Due to the third harmonics currents circulating in the motor windings, a higher setting of the overload relay may be required. This may only be carried out on the basis of utilising a measuring device which records the correct r.m.s. value. Conductor cross-sectional areas must be of a suitable size in order that they will be protected against temperature rises resulting from overload conditions. Therefore, the conductor size selected must be in accordance with the protective device(s) rating.

For motor protection by means of power circuit breakers with motor protection characteristics, the power circuit breaker is switched into the network supply lines, as it also carries out short circuit protection of starter and lines. In this case, the current is set to the rated motor current. A correction of the set value because of the third harmonics is irrelevant under these circumstances. The lines are to be thermally proportioned depending on the power circuit breakers setting.

For normal star-delta starting, the controlgear must be sized in accordance with the following currents:

- Main contactor                      K1M    0.58  $I_e$
- Delta contactor                      K2M    0.58  $I_e$
- Star contactor                        K3M    0.34  $I_e$

For starting times exceeding approximately 15 seconds, a bigger star contactor has to be selected. If the star contactor is equal to the main contactor, start times of up to approximately one minute are permissible.

## 1.1.2 Enhanced star-delta starting

If the torque during normal star-delta starting is insufficient to accelerate the drive in delta connection to the approximate operational speed, then the enhanced star-delta start is utilised. With an increased torque, however, the current consumption during start-up also increases.

A difference is made between:

- combined star-delta starting
- partially wound star-delta starting

Both types require motors with accordingly tapped windings.

The same guidelines for normal star connected starters apply to motor connection, contactor operation, motor protection and thermal conductor sizing.

### 1.1.2.1 Combined star-delta starters

In this case, the motor windings are usually divided into two equal halves. During start, half a winding is switched in delta, the other half in star. Therefore, the term “combined” is used. The star starting current is approximately  $2...4 I_e$ . This results in a correspondingly higher starting torque.

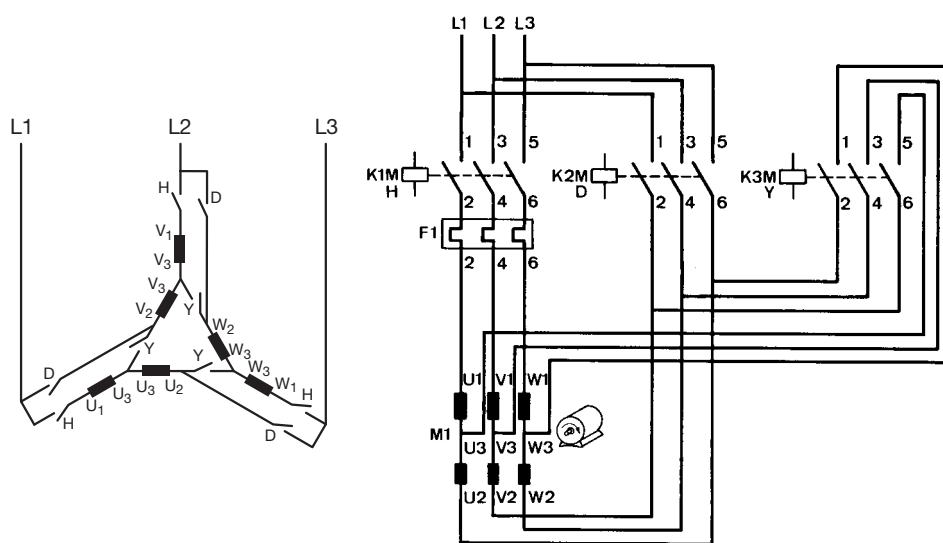

*Combined Star-Delta-Starting*

Sizing of controlgear:

- Main contactor      K1M     $0.58 I_e$
- Delta contactor     K2M     $0.58 I_e$
- Star contactor       K3M     $0.34 I_e$

## 1.1.2.2 Partially wound star-delta starting

In this case, the motor windings are also subdivided. During star connection only the main winding, i.e. a part of the entire winding, is used. Therefore, the term “partially wound” is used. The star starting current - depending on the tapping - amounts to 2...4  $I_e$ , which also results in a higher starting torque.

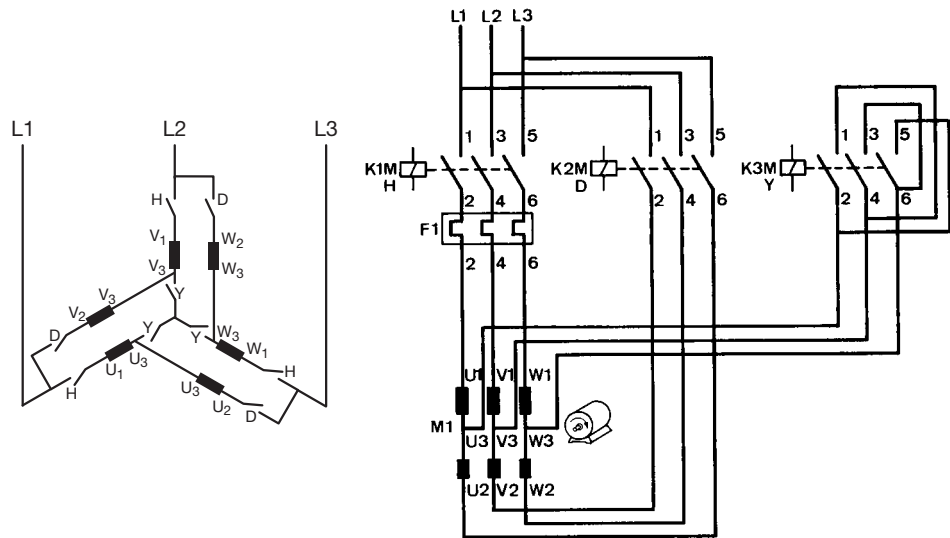

*Partially Wound Star-Delta Starting*

Sizing of Controlgear:

- Main contactor                    K1M     0.58  $I_e$
- Delta contactor                   K2M     0.58  $I_e$
- Star contactor                    K3M     0.5 - 0.58  $I_e$  (depending on starting current)

## 1.1.3 Uninterrupted star-delta starting

This connection prevents a drop in the motor speed during the switch-over from star to delta, and therefore, the following current peak is kept low.

Before the star contactor opens, a fourth (transition contactor) K4M closes the motor circuit via resistors in delta. This prevents an interruption of the motor current during switch-over and the motor speed remains practically constant. Afterwards, the delta contactor K2M creates the final switching status and throws off transition contactor K4M.

# Motor Starting

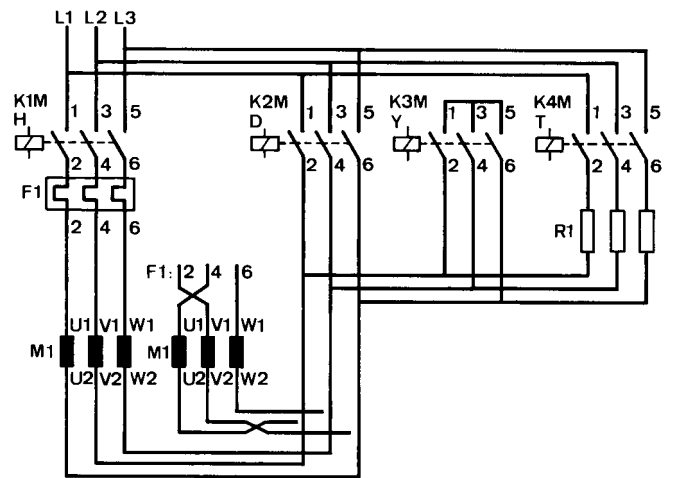
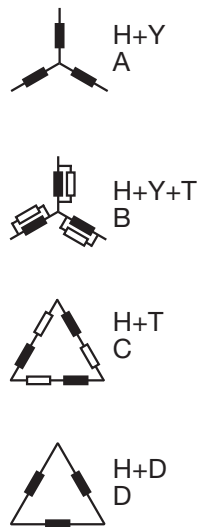

*Uninterrupted Star-Delta Starting*

Sizing of Controlgear:

- Main contactor                    K1M       $0.58 I_e$
- Delta contactor                    K2M       $0.58 I_e$
- Star contactor                    K3M       $0.58 I_e$
- Transition contactor                K4M      typ.  $0.27 I_e$  (depending on transition current)
- Transition resistors                           typ.  $0.35...0.4 U_e/I_e$

The star contactor must have the same dimensions as the main and delta contactor, and this is different from a normal star-delta connection, because it has to switch off the motor's and transition resistor's star current. A current of approximately  $1.5 I_e$  flows in the resistors. Therefore, a correspondingly higher switching performance is required.

The same guidelines for normal star connected starters apply to motor connection, contactor operation (connection differs due to activation of transition contactors), motor protection and thermal conductor sizing.

## 1.2 Autotransformer-starting

An autotransformer starter enables the start of squirrel-cage motors using a reduced starting current, since the voltage is reduced during start. Contrary to a star-delta connection, only three wires to the motor and 3 motor connections are required. This connection is particularly widely used in English-speaking countries.

During start-up, the motor is connected to the autotransformer's tapings. This means that the motor starts up with a reduced voltage and a correspondingly low current. The autotransformer reduces the current in the mains supply line further and in accordance with its ratio. Like the star delta connection, the autotransformer starter has a favourable torque-current take-up ratio.

In order to adapt the motor start characteristics to the torque requirement, autotransformers are usually equipped with three selectable tapings (e.g. 80%, 65%, 50%).

When the motor has almost reached its rated torque, the star connection on the transformer is opened. The transformer's partial windings act as chokes in series to the motor windings, and therefore, like the uninterrupted star delta connection, the motor speed does not drop during switch over. After the main contactor has been switched in, the motor windings are applied to the full mains voltage. Finally, the transformer is disconnected from the mains.

Depending on tapping and the motor's starting current ratio, the starting current amounts to  $1 - 5 \times I_e$ . The available torque is reduced in ratio to the starting current.

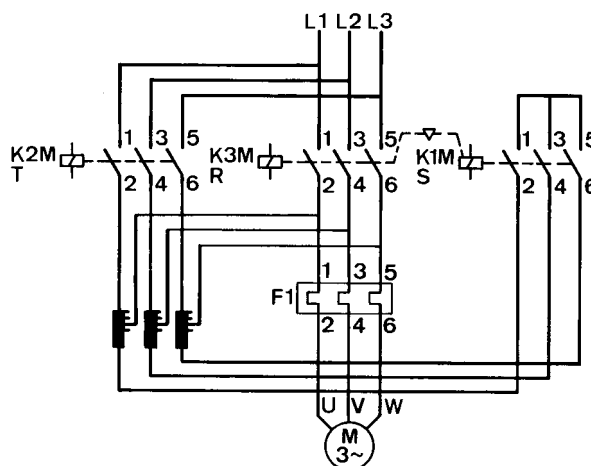

*Auto-transformer starter with uninterrupted switch over (Korndorfer-connection)*

## 1.3 Start via chokes or resistors

The voltage applied to the motor is reduced by ballast chokes or resistors, as is the starting current. The starting torque is reduced by the square of the current reduction.

### 1.3.1. Starting via chokes

During the off state, the motor resistance is low. A large percentage of the mains voltage is reduced at the ballast chokes. Therefore, the motor's starting torque is considerably reduced. As the torque increases, the voltage applied to the motor increases due to a reduction in current consumption and the vectoral voltage division between motor and the ballast reactance. This leads to an increased motor torque. After a successful run-up, the chokes are short-circuited.

The starting current is reduced depending on the required starting torque.

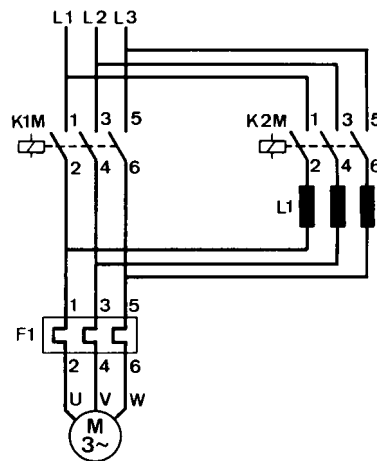

*Start via Chokes*

## 1.3.2. Start via resistors

In this case, cost-efficient resistors are used instead of the above-mentioned chokes.

This method is less helpful in reducing the starting current for the same torque requirement, because the motor torque reduces as a value of the square of the voltage and the voltage applied to the motor increases only due to the motor's reduced current consumption during increasing speed.

It is better to reduce the ballast resistor step by step during start. But this requires considerably more switch gear.

Another possibility is the use of encapsulated wet (electrolytic) resistors. For these resistors, the ohmic resistance reduces in line with the temperature increase caused by the starting current's heating capability.

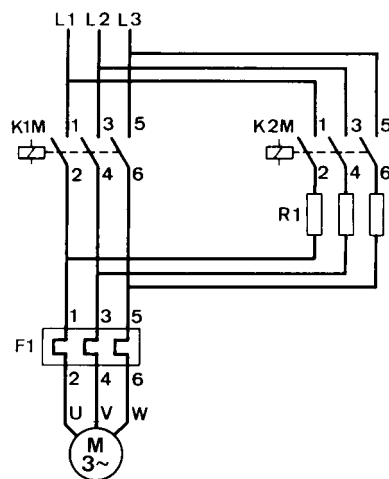

*Start via Resistors*

## 1.4 Multi-speed motors

For asynchronous motors, the speed is determined by the number of poles and the supply frequency.

2 poles =	3000 min <sup>-1</sup>	(synchronous speed)
4 poles =	1500 min <sup>-1</sup>	
6 poles =	1000 min <sup>-1</sup>	
8 poles =	750 min <sup>-1</sup>	
etc.		

Motors with two or more speeds can be built by a suitable switch-over of tapped windings or by separate windings per speed in the same motor. The Dahlander connection, which can achieve two speeds with a 1:2 ratio with only one winding, is especially cost-efficient.

Multi-speed motors can be professionally operated at both speeds and are used, for example, for ventilators to change the output. This is their main application area.

Depending on the design and switching of the windings, there are motors which achieve approximately the same output or torque at different speeds. For lower speeds, the same torque results in lower currents, which makes starting with a high torque requirement and small current consumption manageable.

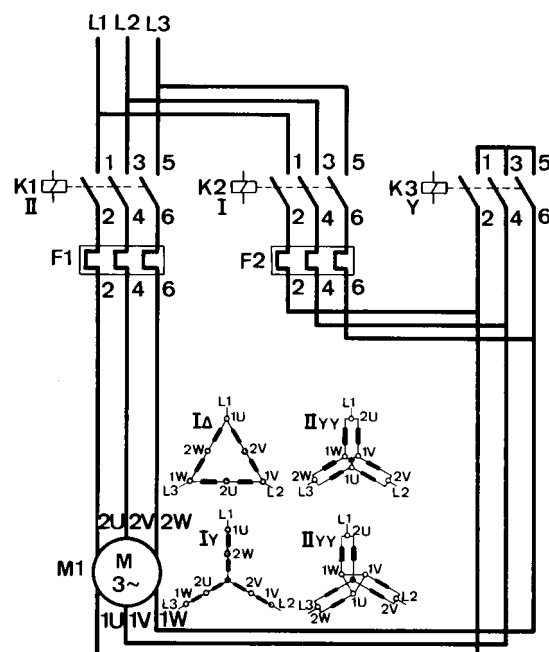

Multi-speed motor





## 2 Soft starters

### 2.1 General

Depending on the network supply quality, rapid load current changes which occur during motor start up can cause voltage drop which may affect devices fed by the same network:

- brightness fluctuations affecting lighting
- interference with computer systems
- contactor and relay drop outs

Mechanical machine or plant components are put under severe stress by torque surges which occur during starting.

Traditional solutions like

- Star-delta connection
- Autotransformer
- Chokes or resistors

can influence the voltage applied to the motor terminals and, hence, the current, only step by step.

The soft starter controls the voltage without steps from a selectable starting value up to 100 per cent. This continuously increases the torque and also the current. This means that the soft starter enables loaded motors to be started smoothly, without the steps associated with electro-mechanical starters.

## 2.2 Soft-starter implementation

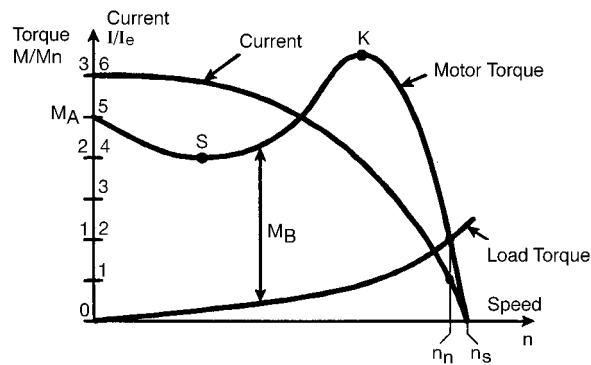

*Characteristic motor curves*

With the help of a characteristic motor torque curve, it can be explained how a gradual motor start can be achieved.

If the load curve is compared with the characteristic motor curve, it can be seen that the motor torque curve always lies above the load torque curve until both curves meet.

At this point the rated torque is achieved under the rated load.

The difference between the load torque curve and the motor torque curve is termed the acceleration torque ( $M_B$ ). This torque generates the energy which causes the drive to turn and accelerate

The ratio of these two curves measures a drive's start or run up time. If the motor torque is much higher than the load torque, this means that the acceleration energy is high which results in a correspondingly short run up time. But if the motor torque is only a little higher than the required load torque, this results in low acceleration energy and, therefore, the run up time increases correspondingly.

This means that the soft-start is achieved by reducing the acceleration torque.

## 2.2.1 Motor torque reduction

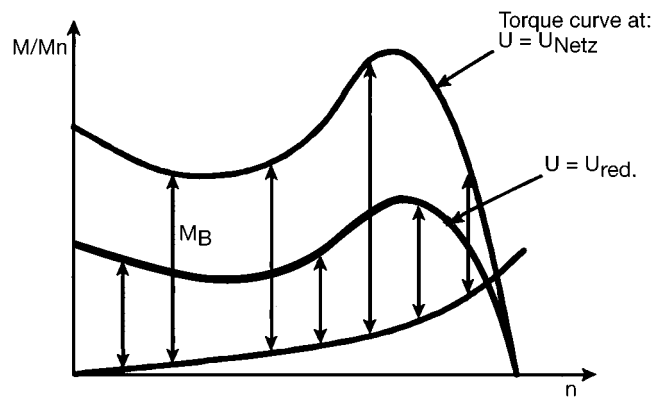

*Torque curves*

The motor curves shown only apply if the full mains voltage  $U_N$  is available. As soon as a lower voltage is applied, the torque reduces as a square of this value. For example, if the effective motor voltage is reduced by 50%, the torque is reduced to a quarter. If the torque curves are compared, it can be seen that the difference between the load curve and the torque curve is much higher at mains voltage than at reduced voltage. The motor torque and, therefore, the acceleration power can be influenced by changing the motor voltage.

## 2.2.2 Influencing the motor voltage

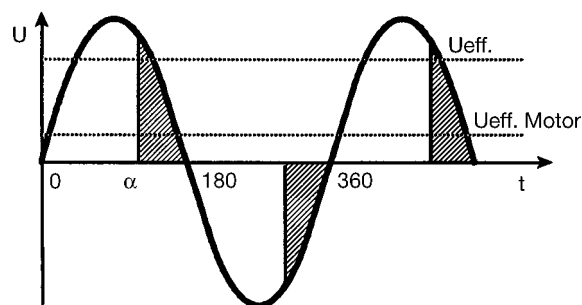

*Phase angle*

It is easiest to change the motor voltage by means of a phase angle control. Using a controllable semiconductor, the thyristor, it is possible to pass on only a certain percentage of the voltage to the motor by phase control. The point of time from which the thyristor conducts the sine half wave is called ignition angle 'Alpha'. If the angle 'Alpha' is big, the average motor voltage is low. If the ignition angle 'Alpha' is slowly shifted to the left, the motor voltage increases. With the corresponding control, the phase angle is a good and simple method for changing the motor voltage.

## 2.3 Starter types

In general, there are two possibilities for starting up a motor using a soft starter. These are a start using a voltage ramp and a start using limited current.

### 2.3.1 Start by means of a voltage ramp

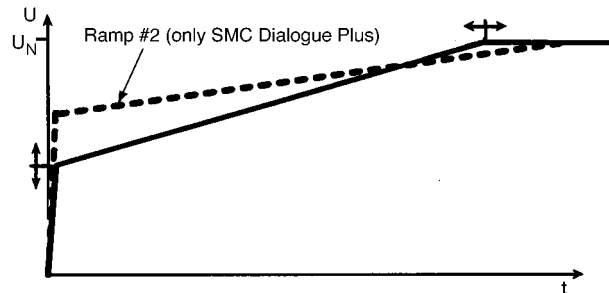

*Voltage Ramp*

Starting with a voltage ramp, the start or run-up time and the breakaway torque are preset.

The soft starter increases the motor terminal voltage linearly from a preset initial value (initial torque) to the full mains voltage. The low mains voltage at the beginning of the starting process results in a low motor torque and causes a gentle acceleration process. The initial voltage to be preset is determined by the breakaway torque = starting torque of the motor. With the SMC Dialogue Plus, the opportunity exists to choose between two soft start profiles with separately adjustable ramp-up times and initial torque values.

The motor's run up time results from the preset values for run up time and initial torque. If a very high initial torque or a very low run up time is selected, one is close to a direct start. In real life, the run up time is determined first and then the initial torque is set in such a way that the desired soft start is achieved.

**The preset run up time is not the real run up time of the drive; it is dependent on the load and the set initial torque.**

During a soft start by means of a voltage ramp, the current starts at a certain level, increases to a maximum value and drops back to  $I_N$  when the motor's rated speed is reached. The maximum current cannot be determined in advance, since it sets itself depending on the motor. If, however, a certain current is not to be exceeded, then the start up can be selected by means limiting the current

## 2.3.2 Start by means of a current limitation

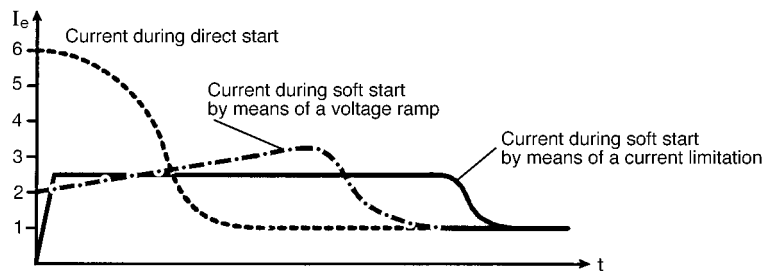

*Current curves during run up*

The current increases in line with a certain ramp until it has reached the set maximum and falls back to  $I_N$  when the motor's rated speed has been reached. This means that the motor can only draw a certain start up current. The start up method is often required by the electricity companies if a large motor (fans, pumps) are to be connected to the public grid.

## 2.3.3 Torque

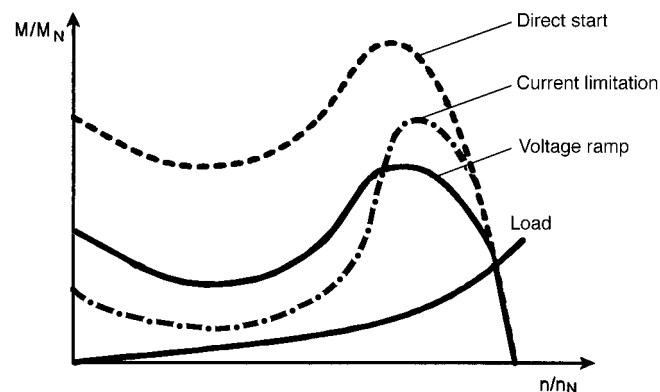

*Torque curves*

This diagram shows the different motor torque for direct start, soft start with a voltage ramp and with current limit.

## 2.4 Soft starter types

The differences between the different soft starter types lie, above all, in the structure of the power component and the control characteristics.

As already mentioned, the soft starter is based on the phase angle principle. By means of thyristors it is possible to switch at different points the sine half wave and supply only part of the mains voltage to the motor.

The thyristor permits the current to flow in one direction only. This requires a second semiconductor with opposite polarity which supplies the negative current (back-to-back switched semiconductors).

Soft starters are divided into groups according to the following criteria:

1. The number of controlled phases.

One phase (single-phase controlled soft starters), two phases (two-phase controlled soft starters) or three phases (three-phase controlled soft starters).

2. The type of the second semiconductor with opposite polarity.

If a diode is selected, this is called a half-wave controlled soft starter.

If a thyristor is chosen, this is called a full-wave controlled soft starter.

The following circuit diagrams show how the different types influence motor voltage and current in different ways.

## 2.4.1 Single-phase full-wave controlled soft starter

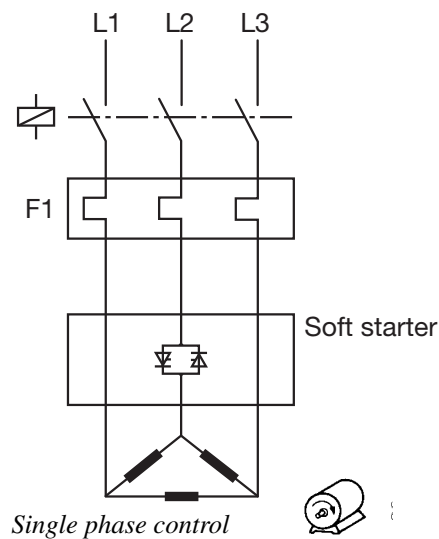

In case of the single-phase controlled soft starter, a phase angle (Phase L2) is implemented in a phase by means of two back-to-back thyristors. The phases L1 and L3 are directly connected to the motor.

During start, approximately the 6 x rated motor current still flows in phase L1 and L3. It is only possible to reduce the current to the 3 x rated current during the controlled phase.

If this method is compared with a direct start, the run-up time is longer, but the total average motor current is not considerably reduced. This means that approximately the same current flows through the motor as during direct start. This results in an additional motor warm-up. Since only one phase is controlled the network is put under an asymmetrical load in the start phase. This method corresponds to the classical KUSA-connection.

Single and two-phase controlled soft starters are mostly used in a power range of up to max. 5.5 kW. They are only suitable for avoiding mechanical impact in a system. The induction motor's starting current is not reduced by this method.

## 2.4.2 Three-phase half-wave controlled soft starter

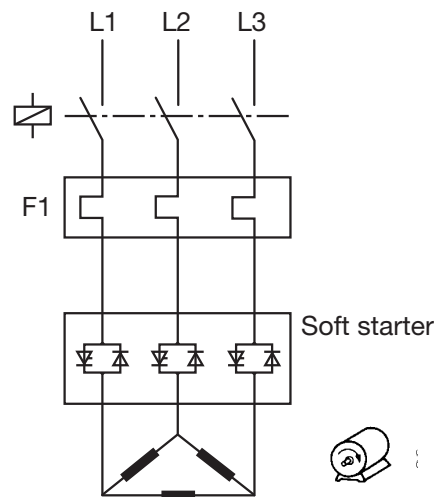

*Half-wave control*

For a three-phase half-wave controlled soft starter, the phase cut is implemented in all three phases. A thyristor with an anti-parallel diode serves as a power semiconductor. This means that the phase control is only implemented in one half-wave (half-wave controlled). This means that the voltage is only reduced during the half-wave when the thyristor conducts. During the second half-wave, when the diode conducts, the full mains voltage is applied to the motor.

During the uncontrolled half-wave (diode), the current peaks are higher than during the controlled one. The upper harmonics linked to this result in a further motor warm-up.

Since the current peaks in the uncontrolled half-wave (diode) and the upper harmonics linked to them become critical during high performance, half-wave controlled soft starters can only be applied purposefully up to approximately 45 kW.



### 2.4.3 Three-phase full-wave controlled soft starter

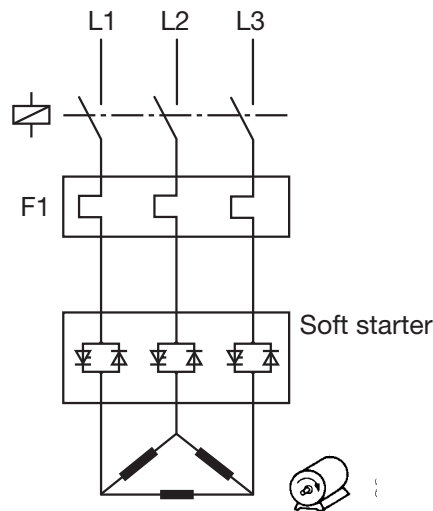

*Full wave control*

For this soft starter type, the phase control is implemented in all three phases. Two back-to-back thyristors are used as power semiconductors. This means that the phase voltage is controlled in both half waves (full wave control). As a result of the upper harmonics occurring during phase control, the motor is nevertheless put under a higher thermal load than during a direct start.

Three-phase full-wave controlled soft starters are applied for up to approximately 630 kW.

### 2.5 Thermal load during start

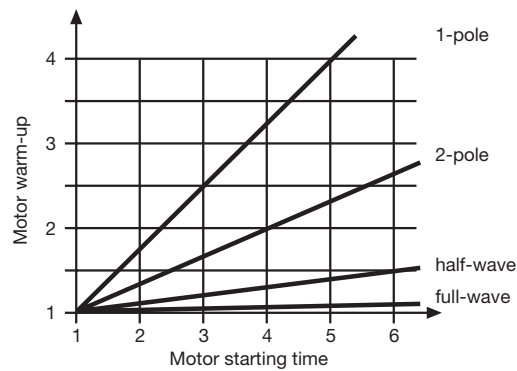

*Motor warm-up*

This diagram shows the impact of different soft starter types on additional motor warm-up compared to a direct start.

Item 1/1 marks the motor warm-up following a direct start. The X-axis shows the multiplication factor of the start time and the Y-axis shows the multiplication factor of the motor warm-up. If, for example, the start time is doubled compared to a direct start, this means that:

- For the single-phase controlled soft starter, the motor warm up is increased to the 1.75 x value;
- For the two-phase controlled soft starter, it is increased to the 1.3 x value;
- For the half-wave controlled soft starter, it is increased to the 1.3 x value;
- For the full-wave controlled soft starter, practically no additional warm-up can be detected.

For longer run-up times and higher power, only a fully wave controlled soft starter can be used.

### **2.6 Advantages of soft starters**

- Increased acceleration time can be beneficial for motor and machine.
- The starting current is reduced or can be limited.
- The torque is adapted to the corresponding load.
- For pumps, surges during start and stop can be avoided.
- Jerky movements and shocks, which could hamper a process, are avoided.
- The wear and tear of belts, chains, gears and bearings is avoided.
- By means of the different controls, simplified automation is possible.

### **2.7 Benefits to the customer**

#### **2.7.1 Mechanical**

During direct start, the motor develops a very high starting torque. Starting torques of 150 to 300% of the rated torque are typical. Depending on the start type, the drive mechanics can be put under excessive strain due to the high starting torque ('Mechanical stress'), or the manufacturing process may be unnecessarily hampered by jerky torque impacts.

- By using a soft starter, the torque impact which occurs on the mechanical parts of a machine can be prevented.
- The start characteristics can be adapted to the application (e.g., pump control).
- Simple wiring to the motor (only 3 conductors).

### 2.7.2 Electrical

Induction motor starting causes high power surges in the network.

(6 - 7-fold rated current). This means that large voltage drops can be caused which disturb other users connected to the network. Therefore, electricity companies determine limiting values for motor starting currents.

- By means of a soft starter it is possible to limit the motor starting current (limited by the amount of starting torque required)
- This reduces the strain on the network.
- Possible reduction of network connection fees.
- In many cases, however, the electricity company requires the starting current to be limited. This means compliance with the respective regulations.

### 2.8 Possible Applications

Typical applications are:

- travelling cranes, conveyor belts, drives
- mixers, mills, crushers
- pumps, compressors, ventilators
- drives with gears, chains, belts, clutches

Pumps:

By means of a special pump control it is possible to eliminate pressure impact, which occurs during pump start and stop.

Compressors:

For compressors, the speed can decrease during switch-over from star to delta. A soft starter ensures a continuous start. A reduction in speed does not occur.

Single-phase motors:

If a single-phase motor is to be powered using a soft starter, a single-phase full-wave controlled soft starter is required.

In general:

The soft starter represents an economical substitute for star-delta systems and offers superior performance. For applications with where a high starting torque is required, a soft starter should be the preferred choice.

## 2.9 Pump start

### 2.9.1 Current and torque development for a star-delta start

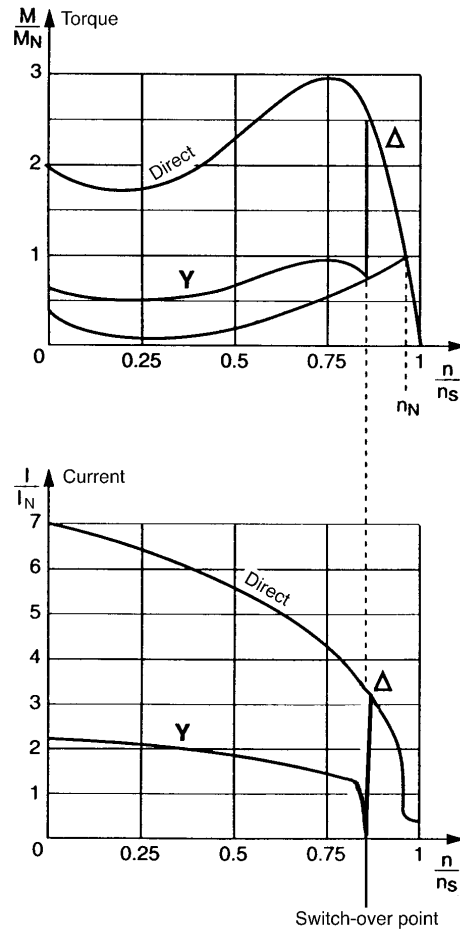

*Star-delta current curves*

The diagram shows the characteristic torque and current curves for a star and a star-delta start depending on the speed. For this application, a star-delta start is unsuitable, as the start is not unloaded. During the switch-over from star to delta, the current drops to zero and the speed decreases depending on the application. The switch-over to delta causes a sudden current increase. This leads to voltage drops in weak networks.

During switch-over to delta, the motor torque also jumps to a high value, which represents a mechanical strain on the entire drive. If pumps are powered using star-delta, a mechanical gate is usually applied.

## 2.9.2 Speed development for starts with a pump soft starter

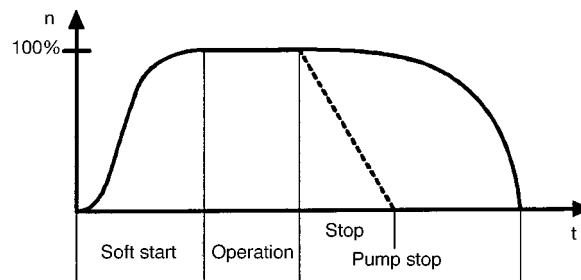

*Speed development for pump control*

A soft starter with a Pump option module does not accelerate the motor linearly. The speed change has the shape of an S-curve. An optimum pump start is achieved by means of a slow start, a fast acceleration and then a longer acceleration time to the rated speed. Stopping a pump represents a high demand to a soft starter. The pump deceleration time needs to be specially controlled so as to avoid surges or water hammer. The soft starter must react automatically to motor load and speed and adapt its parameters accordingly in order to achieve the desired goal.

## 2.9.3 Comparison of torque curves

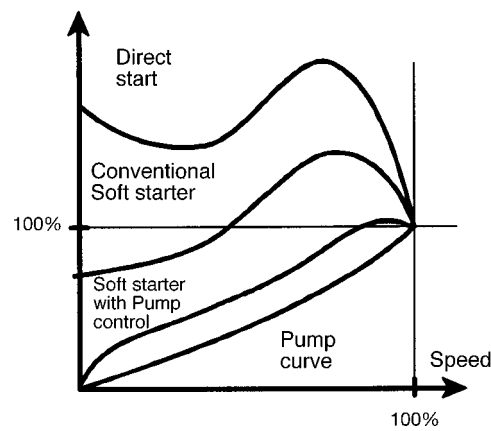

*Torque curves*

This diagram shows the characteristic torque curves for different starting methods. The curve of the soft starter with pump module is parallel to the characteristic pump curve, thus achieving a constant acceleration Torque.

## 2.9.4 Flow curve during start

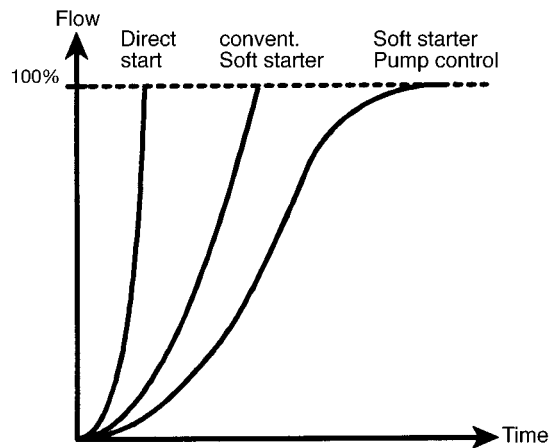

*Flow Curve during start*

This diagram represents the flow curve during start for different starting methods. During a direct start, the liquid is accelerated very quickly. If 100% of the liquid through put is achieved, this results in a huge acceleration change. This results in surges which can cause considerable damage to the plant. For conventional soft starters, the acceleration change is lower and, therefore, the impact on the system is less. Only in soft starters with a special Pump module is the acceleration so low that no surges are caused.

## 2.9.5 Flow curve during stop

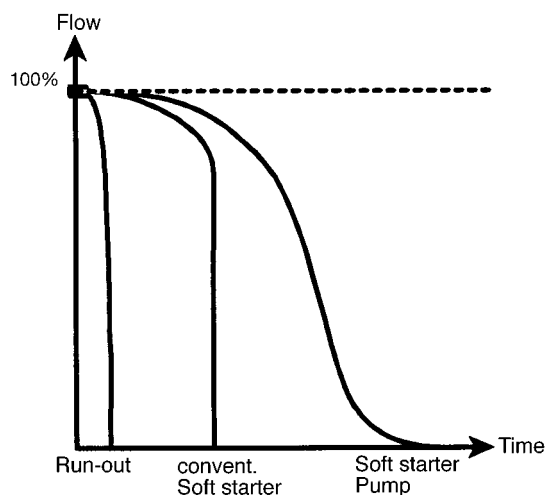

*Flow curve during stop*

This diagram shows the flow curve during stopping for different control methods.

During deceleration, the pumps stops very quickly. This means that the entire water column falls down onto the flap trap. This puts the plant under more mechanical strain than during a direct start.

The conventional soft stop is unsuitable for a pump application, as the flow rate is only delayed to a certain extent and the same effect occurs as before.

An optimum slowing down of the flow can only be achieved by means of a 'regulated' pump stop. As is the same for starting, it is even more important during stopping that no surges occur. The soft starter has to start delaying the flow slowly, increase the delay and decrease it towards the end, so that it is slowly braked to zero again.

### **2.9.6 Requirements for a pump soft starter**

All systems have different height differences and cable lengths, and therefore it is insufficient to back up the characteristic pump curves with corresponding software. The soft starter has to adapt itself to different conditions for pump applications; only this can ensure optimum starting and stopping procedures.

### **2.9.7 Application areas**

Soft starters with a pump module are nowadays used in many areas. Some of these are:

- water supply
- purification plants
- breweries / dairies
- long-distance heating plants
- swimming pools
- food and drinks production
- chemical and petrochemical plants
- mining
- bottling plants
- paper industry
- wood processing

### **2.10 Options**

Different options are offered for soft starters:

- soft stop
- pump control
- leakage speed
- intelligent brakes
- Accu Stop
- leakage speed with brake

These options are described in detail in the Allen-Bradley product catalogue.

### 3 AC variable speed drives

#### 3.1 General

Industry requires higher and higher production speeds, and better methods for even more efficient production systems are developed constantly. Electric motors represent major components of these systems. Therefore, different methods for changing the speed of three-phase induction motors were developed, but most of these are linked to considerable power losses or large investments. The development of inverters permits the efficient use of induction motors with variable speeds.

The modern inverter is an electronic device, which controls the speed of induction motors by changing frequency and voltage according to load and desired motor speed. This means that the motor can achieve a high torque at all speeds, down to 15rpm without motor speed feedback or 0 rpm with feedback.

#### 3.2 Structure

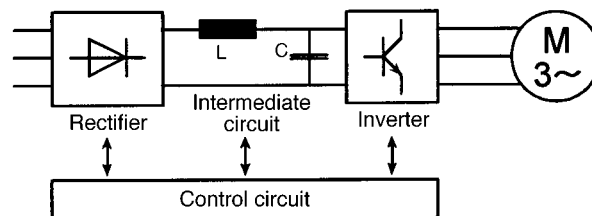

##### *Main structure*

The AC variable speed drive consists of three main components.

##### Rectifier:

The rectifier is connected to the supply network and generates a DC voltage supply which feeds the main DC link elements.

##### Intermediate circuit:

The intermediate circuit stores and smoothes the pulsating direct voltage by using capacitors and inductors

##### Inverter:

Using the DC derived from (A) and (B), the inverter synthesises a variable frequency and voltage with the required frequency and supply which can be varied to control speed/torque of a 3 phase induction motor.

##### Control circuit:

The control circuit is responsible for the operation, monitoring and protection of the entire AC drive. It is here that all input signals to the drive are acted upon to generate the most appropriate way to control the Inverter itself.



### 3.2.1 Mains rectifiers

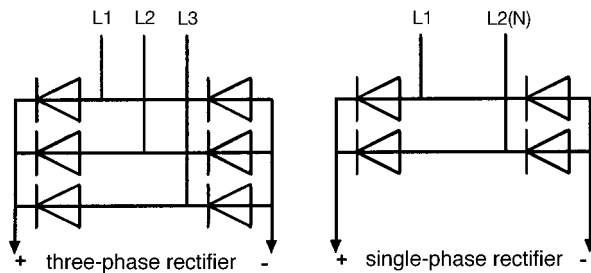

#### Mains rectifiers

The mains rectifier consists of a bridge circuit which rectifies (converts from AC DC) the supply network. The DC voltage resulting from this always corresponds to the peak value of the connected mains voltage ( $U_e \times \sqrt{2}$ ).

The main difference between a single-phase and a three-phase bridge circuit is the voltage level of resulting dc voltage. In real life, a single-phase version is preferred for cost reasons for low capacity drives (up to approx. 2.2 kW). For the following reasons this version is unsuitable for higher capacities:

The single-phase bridge represents an unbalanced load for the network. The direct voltage harmonic ripple is considerably higher than for the three-phase model. This means that the intermediate circuit's capacity has to be increased to compensate.

The AC variable speed drive's rectifier comprises of either diodes or thyristors. A rectifier consisting of diodes is called uncontrolled, one consisting of thyristors, controllable. The Diode Bridge is used for motor capacities of up to approx. 22 kW.

#### 3.2.1.1 Principle Diagram of rectified power supply

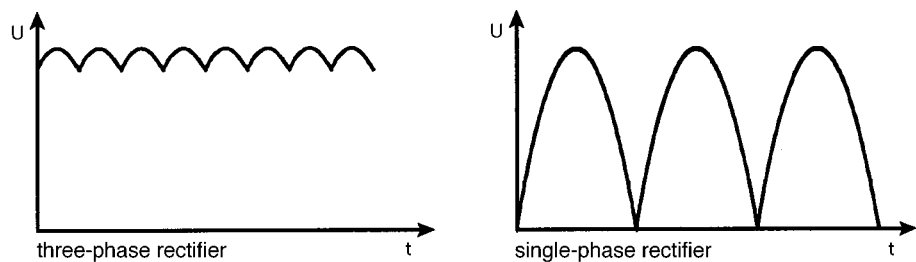

mains rectifier

## 3.2.2 Intermediate circuit

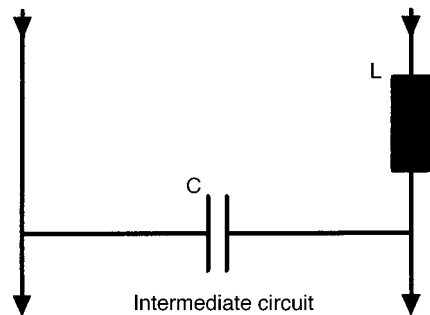

### *DC-intermediate circuit*

The intermediate circuit can be regarded as a store from which the motor draws its energy via the inverter. The intermediate circuit's capacitor C buffers the mains energy, which requires a high capacity. The motor connected to the drive draws energy from the intermediate circuit, and the capacitor is partially discharged during this process. The capacitor can only be charged when the mains voltage exceeds the intermediate circuit's voltage. This means that the energy is provided by the supply when the mains voltage is close to its maximum. This results in current peaks which add up if several drives are switched in parallel. Therefore, an intermediate circuit DC link reactor is installed for higher powers (from approx. 5.5 kW). This iron core choke ensures that the current flow period on the mains side is delayed and thus current peaks are reduced.

## 3.2.3 Inverters

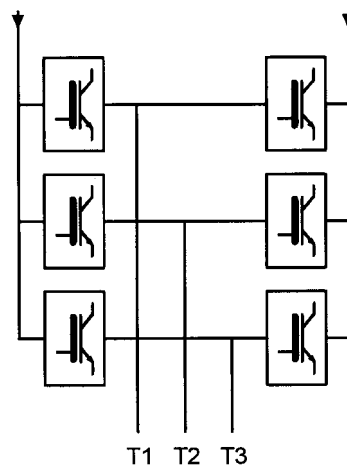

### *IGBT-Inverter*

The inverter itself is the last main drive element in front of the motor. (For multi-motor drives, an additional protection before the motor is required.) It changes the dc voltage into a supply having variable frequency and voltage. Various switching devices are used such as :

BJT (Bipolar Junction Transistor), GTO (Gate Turn Off Transistor), FET (Field Effect Transistor), IGBT (Insulated Gate Bipolar Transistor). Modern AC drives are usually equipped with IGBT. The new generations of these semiconductors achieve high performances of up to approx. 350 kW.

How can a dc supply be transformed into an AC supply with variable voltage and frequency? The inverter's components act as switches (controlled by a microprocessor) and, depending on the frequency, switch positive or negative voltage to the motor winding. For most ac drives, the frequency and voltage changes are achieved by means of pulse width modulation (PWM).

### 3.2.3.1 Principle diagram of pulse width modulation

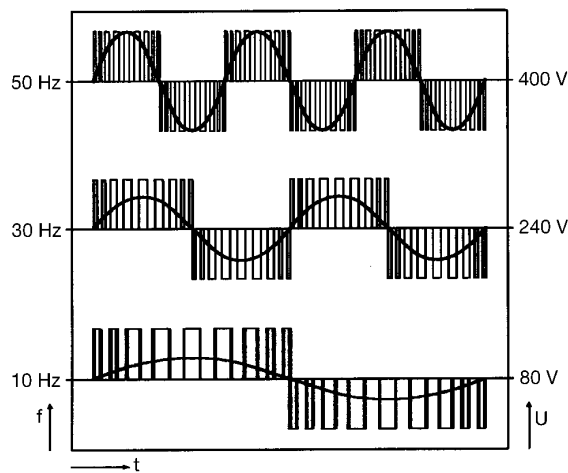

*Pulse width modulation*

## 3.3 Operational behaviour

### 3.3.1 Frequency-voltage ratio

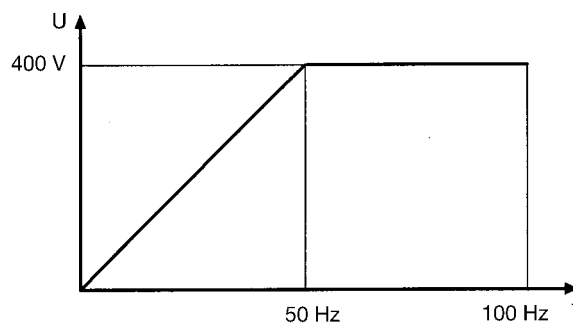

*U-f-curve*

A direct connection of the motor to a standard AC supply network creates ideal operational conditions for the motor. The AC variable speed drive operates by providing near optimum conditions of voltage frequency and current approaching mains performance, by changing the voltage, a good approach to these operational conditions.

A linear voltage/frequency relationship from 0 to 50 Hz and 0 - 400 V serves as standard for most applications. If the frequency exceeds 50 Hz, the voltage is not increased further (deliberately limited to input voltage) and the motor can no longer achieve the rated output and therefore cannot be fully loaded.

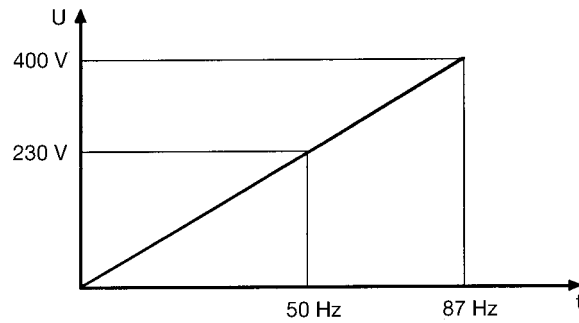

*U-f-curve*

To operate higher than nominal frequency (eg. 87 Hz), the motors connection has to be changed so that the frequency limit (usually 50 Hz) can be increased without excessive stress on the motor. A standard ratio is:

230V - 50 Hz and 380 V - 87 Hz. This means that the motor can be operated with a nominal load (at constant torque) of up to 87 Hz.

### 3.3.2 Voltage increase or boost

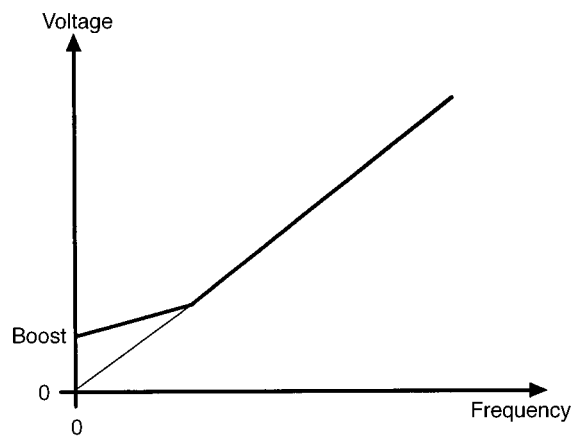

*Voltage increase*

The linear V/F ratio provides very low torque at low frequencies (< 5 Hz). The motor has almost no torque, so that it stops during low speed. To avoid this, a voltage increase or “boost” has to be set for low speeds. Depending on the drive type, the user can achieve this in several ways:

Auto-Boost:

The voltage increase is determined by the inverter’s software. This type of torque boost covers the majority of applications.

Torque Boost:

The V/F ratio is biased with a fixed voltage only at low frequencies. It has to be considered, however, that the motor current rises very steeply when applying torque boost, care should be shown in setting to avoid motor over heating.

### 3.3.3 Slip compensation

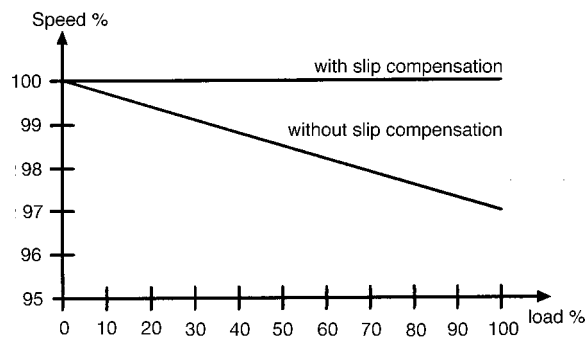

*Slip compensation*

If a three-phase induction motor is loaded, its speed decreases while its slip increases (usually 3-5%). If such a speed reduction is undesirable, then the drive may use slip compensation, i.e. the drive automatically increases the output frequency so that the speed does not decrease. This compensation permits a speed accuracy of approx. 0.5 %, although lower errors can be programmed if required.

### 3.3.4 Reference

The Reference determines the drive output frequency and thus the speed of the connected motor. The reference can be fed to the drive in various ways:

- by means of a potentiometer (typically 10 kOhm)
- by means of an analogue signal (0...10V or 4...20 mA)
- via a serial interface
- via a field bus (eg. DeviceNet)

It is also possible to program different set frequencies in the drive and to activate these via inputs if and when required. (Digital inputs)

### 3.3.5 Harmonic Compensation

As mentioned, a reactive and active currents low in the motor circuit. The reactive current, however, alternates between the intermediate circuits capacitor and the motor inductance and does not burden the supply. Only the active power, the drive losses and the ac drive losses are drawn from the power supply side. The fundamental mains current (50HZ) cost is therefore almost 1.

### 3.3.6 Motor protection

Modern AC drives are usually equipped with an integrated electronic motor protection device, therefore additional motor protection is normally not required. For special applications, e.g. when one drive supplies several motors, additional motor protection is recommended for each branch connected to a motor. Attention has to be paid, however, that the motor can also be operated at low speeds. As standard motors have the fan mounted on the shaft, optimum cooling of the motor is no longer ensured. In this case, a remote fan should be installed. In order to guarantee protection at low speeds, temperature sensors, eg. thermistors (PTC), have to be installed in the motor windings and fed back to a supervisory control circuit.

### 3.3.7 Direction reversal & braking

As the driver's rotating field is generated electronically, a simple control command is sufficient for changing the motor's rotation.

If the drive frequency is reduced while the motor is running, the rotor turns faster than the rotating field in the stator. The motor is running in the so-called oversynchronous mode and acts as an induction generator. This means that energy from the motor is fed back to the drive, where it is in turn stored in the intermediate circuit (de link) again. Only a limited amount of energy can be absorbed and the excess energy leads to a voltage increase on the dc capacitors. If the voltage exceeds a certain value, the drive switches itself off (microprocessor controlled). To avoid this (in high dynamic loads), the energy has to be dissipated. This can be achieved in various ways.

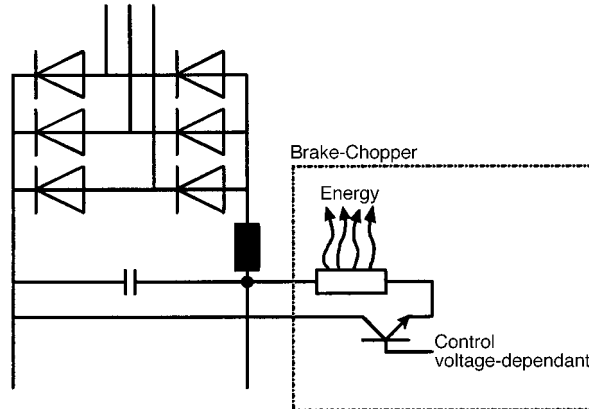

*Brake-Chopper*

Brake-Chopper:

Energy is dissipated by means of a semi conductor switch connected to a resistor and the transistor only switches on as required by the load condition (braking duty < 30%).

Feed-Back:

Energy is fed back into the network by means of a separate inverter which re-synthesises the energy and synchronises it with the power supply (braking duty = 100%).

Common DC bus:

The intermediate circuits of several drives can be connected together. This means that the brake energy for one drive is fed back to other drives (which may not be braking).

### **3.4 Advantages of AC drives**

Energy saving:

Energy is saved if the motor runs at a speed corresponding to the load requirement at that moment. This applies to pumps and fans in particular. Current consumption is also reduced during low speed and high torque conditions.

Process optimisation:

Adapting the speed to the production process results in several advantages, for example: efficient production and optimum use of systems. The speed can be adapted optimally to the external conditions detected by sensors mounted on the process itself.

Reducing Mechanical Stress:

The number of starts and stops can be increased compared to DOL operation. This means that an unnecessarily high stress on the machine mechanics can be reduced. (Improved belt wear etc)

Low maintenance requirement:

AC drives require only periodic maintenance (fans, filters, connections) and since they are usually digital, require only occasional adjustment.

Improved working surroundings:

A conveyor belt's speed can be adapted to the working speed, so slow starts and stops, which prevent the products on the conveyor belt from falling over, can be avoided.

### **3.5 Radiofrequency Interference (RFI)**

#### **3.5.1 General**

Every current and voltage generated in addition to the pure sine wave implies harmonics have been produced. The frequency of these harmonics depends on the current or voltage curve's slope.

If, for example, a contact is closed, the current increases suddenly (very steeply) from zero to the nominal current. In a radio, this can be heard as a crackling noise (usually on AM). A single noise impulse is not perceived as disturbing. Since a frequency inverter's power semiconductors act as conductors these devices emit radio frequency interference voltages. Other electronic devices can be disturbed due to the relatively high switching frequency (2 - approx. 8 kHz).

Radio frequency interference (RFI) is defined as harmonics with frequencies between 150 kHz - 30 MHz. They are distributed by the power supply network or by free space radiation. The strength of the interference depends on various factors:

- the impedance conditions in the supply
- the inverter's switching frequency
- the initial voltage's frequency
- the drive's mechanical structure (metal or plastic components)

### 3.5.2 Standards

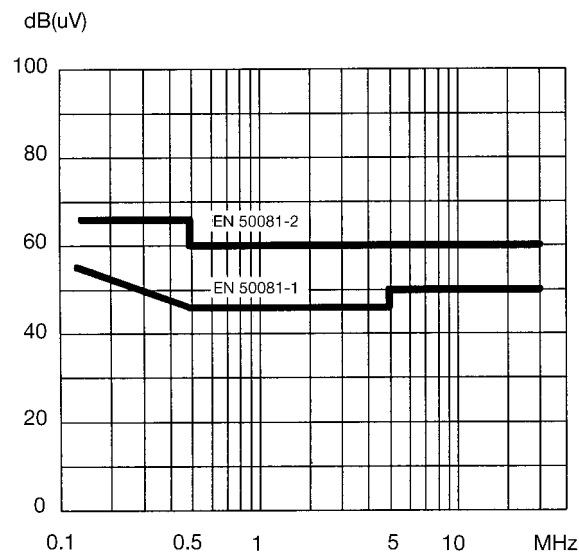

#### *EMC Standard*

Different countries have implemented standards about how much radio interference a device can legally emit. If the different standards are studied, it can be seen that most of them have approximately the same content. In general, two levels are always determined: the curve for industrial appliances (EN 50081-2) and those for commercial purposes (EN 50081-1). A new standard is now in force in Europe, specifically written to cover both AC and DC variable speed drives' this is known as EN 61800 (1-3) and is based on IEC 1800 (1-3). Standards have more legal force than generic standards in the EU (the only place that the CE marking directive applies).



### 3.5.3 Countermeasures

Basically, radio interference is emitted via radiation or via cables. Precautions, however, can only be effective if the installation guidelines are observed. Special attention has to be paid to high diameter earthing connections. AC drives and filters should be mounted on the same conducting mounting plate, to ensure low impedance earth paths.

#### Radiation:

If the inverter is installed in an earthed metal casing, no problems should be expected with regard to radiation.

#### Supply lines to the AC drive:

The strictest standards can only be observed if RFI-filters are applied. An installed DC link reactor does help limit some RFI conduction, and in high power drives a secondary RFI filter may be an unnecessary expense (EN 61800 recognises this fact).

#### Motor cables:

Radio interference in motor cables can also be limited by means of RFI-filters. The filters will, however, be quite big and have high losses. It is therefore normal to limit cable radiation in motor cables by means of screening the conductors either in a shielded cable or conduit (which has been earthed).

Starting procedures for squirrel-cage standard motors compared (typical values)

Start type	Direct		Star-delta		Transformer		Series-Impedances		Special Motors		Start using electronic controls	
	Direct start	Normal	Uninterrupted Switchover	Enhanced	Autotransformer start	Start via chokes	Start via resistors	Multi-stage start	Start with soft starters	Start with frequency inverters		
<b>Mains</b>	high capacity	weak	weak	medium	weak to medium	medium	medium	medium to strong	medium to strong	Low kVA		
<b>Load during start</b>	full	low	low	medium	weak to medium	medium	weak	medium to full	medium to strong	weak to medium		
<b>Relative Starting Current <math>I_{st}/I_e</math></b>	$I_{st}/I_{AD}=4...8I_e$ determined by motor (60%+)	$I_{st}=0.33M_{AD}$ (1.3...2.7 $I_e$ )	$I_{st}=0.33M_{AD}$ (1.3...2.7 $I_e$ )	$I_{st}=-0.5I_{AD}$ (2...4 $I_e$ )	$I_{st}=k^2I_{AD}$ (kE tapping; typ. 80%; 65%; 50%)	typ. 0.8 $I_{AD}$ (2...4 $I_e$ )	typ. 0.5 $M_{AD}$ (2...4 $I_e$ )	$I_{st}=0.5...1M_{AD}$ depending on motor and connection	$I_{st}=kI_{AD}$ (typ. 2...6 $I_e$ ) (kE voltage reduction factor)	$I_{st} \leq 1...2I_e$		
<b>Relative Starting Current <math>M/M_e</math></b>	$M_{AD}=1.5...3M_e$ determined by motor (300% typ.)	$M_{st}=0.33M_{AD}$ (0.5...1.0 $M_e$ )	$M_{st}=0.33M_{AD}$ (0.5...1.0 $M_e$ )	$M_{st}=-0.5M_{AD}$ (0.7...1.5 $M_e$ )	$M_{st}=k^2M_{AD}$ (kE tapping; typ. 80%; 65%; 50%)	typ. 0.25 $M_{AD}$ (0.4...0.8 $M_e$ )	typ. 0.25 $M_{AD}$ (0.4...0.8 $M_e$ )	$M_{st}=0.5...1M_{AD}$ depending on motor and connection	$M_{st}=k^2M_{AD}$ (kE voltage reduction factor)	Start frequency controlled. Torque can be adapted to load requirements within wide limits.		
<b>Run-up time</b>	0.2...5 s	2...15 s	2...15 s	2...10 s	2...20 s	2...20 s	2...20 s	0.2...10 s	0.5...10 s	0.5...10 s		
<b>Normal start</b>	5...30 s	15...60 s	15...60 s	10...40 s	20...60 s	Usual for loaded run.	Usual for loaded run.	5...30 s	10...60 s	5...60 s		
<b>Loaded run-up 1)</b>	High acceleration with high starting current during switchover	Start with reduced torque and current; current and torque peaks	As Y-D normal; considerably reduced current and torque peak during switchover	As Y-D normal, but with increased starting current and torque	Similar to Y-D, but without switchover-interruption and selectable steps	Voltage and motor (and thus relative torque) increases with speed	Voltage and torque increased less with speed than with chokes	Starting current and torque depend on motor and connection as, e.g. for Y-D.	Adjustable starting characteristics. Controlled run-out also possible. Relatively less torque for	High usable torque with low current. Adjustable starting characteristics.		
<b>Application Area</b>	Drives in areas where the power supply is high capacity, which permit the high starting torque	Drives which are only loaded after run-up.	As Y-D normal, but for drives with less inertia mass and a higher resistance torque	Drives with higher torque requirement during start.	Predominantly English-speaking countries. Like Y-D start types.	Drives with resistance torque which increases with speed.	Cost-efficient; for unloaded start. With resistance steps more expensive but also more flexible.	Mostly for operational influence on speed	Starts, which require gentle or adjustable torque curve (or current reduction)	Usually for operational speed adjustment. For small capacities, also instead of soft starters.		

$I_{st}$ ...Motor-starting current

$I_{AD}$ ...Motor-starting current for direct start

$M_{AD}$ ...Motor-Starting torque for direct start

$I_e$ ...rated operating current of Motor

$M_e$ ...rated operational torque of Motor

1) Dimensioning possible in timescales of minutes



Rockwell Automation helps its customers receive a superior return on their investment by bringing together leading brands in industrial automation, creating a broad spectrum of easy-to-integrate products. These are supported by local technical resources available worldwide, a global network of system solutions providers, and the advanced technology resources of Rockwell.



## Worldwide representation.

Argentinien • Australia • Austria • Bahrain • Belgium • Brazil • Bulgaria • Canada • Chile • China, PRC • Colombia • Costa Rica • Croatia • Cyprus • Czech Republic • Denmark • Ecuador • Egypt  
El Salvador Finland • France • Germany • Greece • Guatemala • Honduras • Hong Kong • Hungary • Iceland • India • Indonesia • Ireland • Israel • Italy • Jamaica • Japan • Jordan • Korea  
Kuwait • Lebanon • Malaysia • Mexico • Netherlands • New Zealand • Norway • Pakistan • Peru • Philippines • Poland • Portugal • Puerto Rico • Qatar • Romania • Russia-CIS • Saudi Arabia  
Singapore • Slovaki • Slovenia • South Africa, Republic • Spain • Sweden • Switzerland • Taiwan • Thailand • Turkey • United Arab Emirates • United Kingdom • United States • Uruguay • Venezuela  
Yugoslavia

Rockwell Automation Headquarters, 1201 South Second Street, Milwaukee, WI 53204 USA, Tel: (1) 414 382-2000, Fax: (1) 414 382-4444

Rockwell Automation European Headquarters SA/NV, avenue Herrmann Debrouxlaan, 46, 1160 Brussels, Belgium, Tel: (32) 2 663 06 00, Fax: (32) 2 663 06 40

Rockwell Automation Asia Pacific Headquarters, 27/F Citicorp Centre, 18 Whitfield Road, Causeway Bay, Hong Kong, Tel: (852) 2887 4788, Fax: (852) 2508 1846